

5.1 Model List

Frame		T18	T25	T50	T65	T100		N120	N120TA	N220	N400	N600											
Appearance																							
Model Name	Standard with 2-Element	TH-T18 For Independent Mounting UT-HZ18 + TH-T18	TH-T25	TH-T50	TH-T65	TH-T100		TH-N120	TH-N120TA TH-N120TAHZ	TH-N220RH TH-N220HZ	TH-N400RH TH-N400HZ	—											
	With 3-Element (2E)	TH-T18KP For Independent Mounting UT-HZ18 + TH-T18KP	TH-T25KP	TH-T50KP	TH-T65KP	TH-T100KP		TH-N120KP	TH-N120TAKP TH-N120TAHZKP	TH-N220RHKP TH-N220HZKP	TH-N400RHKP TH-N400HZKP	TH-N600(Note 3) TH-N600KP(Note 3)											
	Outline Drawing [mm] W x H x D	46 x 55 x 76.5 For Magnetic Starters 46 x 63 x 82.7 For Independent Mounting	63 x 53 x 80	74.3 x 74 x 88	89 x 57 x 83.5	89 x 68.5 x 83.5		103 x 67 x 105	112 x 87 x 105 112 x 103 x 105	144 x 114 x 179 144 x 104 x 166.5	144 x 160 x 193 144 x 173 x 166.5	— 63 x 42 x 83.5											
	Applicable Standard	JIS C8201-4-1, IEC60947-4-1, EN60947-4-1, GB14048.4							JIS, JEM, IEC, VDE, BS, UL, GB														
Use Conditions		Ambient Temperature [°C] -10 to +40 (Standard is 20°C, Inner Panel Maximum Temperature is 55°C)							Ambient Temperature [°C] -10 to +40 (Standard is 20°C, Inner Panel Maximum Temperature is 55°C)														
		Frequency [Hz] 0 (DC) to 400							Frequency [Hz] 0 (DC) to 400														
Rated Insulation Voltage [V]		690							690														
Rated Impulse Withstand Voltage [kV]		6							6														
Pollution Degree		3							3														
Specifications of the Main Circuit		Heater Designation (Adjustment Range of Settling Current) [A]		29 (24 to 34) 35 (30 to 40) 42 (34 to 50)		15 (12 to 18) 22 (18 to 26) 29 (24 to 34) 35 (30 to 40) 42 (34 to 50) 54 (43 to 65)		67 (54 to 80) 82 (65 to 100) 95 (85 to 105)		42 (34 to 50) 54 (43 to 65) 67 (54 to 80) 82 (65 to 100)		105 (85 to 125) 125 (100 to 150) 82 (65 to 100) 105 (85 to 125) 125 (100 to 150) 150 (120 to 180) 180 (140 to 220) 210 (170 to 250)		105 (85 to 125) 125 (100 to 150) 150 (120 to 180) 180 (140 to 220) 250 (200 to 300) 330 (260 to 400)		250 (200 to 300) (Current Transformer Ratio: 400/5 A) 330 (260 to 400) (Current Transformer Ratio: 500/5 A) 500 (400 to 600) (Current Transformer Ratio: 750/5 A) 660 (520 to 800) (Current Transformer Ratio: 1000/5 A)							
		(The --- line in the table on the right represents the correspondence between the magnetic contactor and frame to be combined) (Refer to the relevant text regarding the heater designation of the applied products)		11 (9 to 13) 15 (12 to 18) 22 (18 to 26)										*The thermal overload relay with the heater designation of 180A or less is the same as the N220 frame.									
Power Consumption [VA/Element] Minimum/Maximum Settling		0.8/1.8		1.0/2.1		1.6/3.2		2.4/5.5		2.5/6.0		3.0/7.1		3.8/8.6		1.0/2.3 (Note 4)		1.0/2.3 (Note 4)		1.0/2.3 (Note 4)			
Terminal Screw Size		M3.5		M4		M5		M6		M6		M8		M8		M10		M12		—			
Terminal-Compatible		Wire Size [mm ²] φ1.6, 0.75 to 2.5 Crimp Lug Size 1.25-3.5 to 2-3.5, 5.5-S3		φ1.6 to 2.6, 1.25 to 6 1.25-3.5 to 2-3.5, 5.5-S4		φ2 to 3.6, 4 to 14 5.5-5 to 14-5		— 5.5-5 to 22-6		14-6 to 22-6, 38-S6		— 8-8 to 38-8		— 38-8 to 100-8		22-10 to 150-10		22-12 to 200-12		—			
Contact Arrangement		1a1b		1a1b		1a1b		1a1b		1a1b		1a1b		1a1b		1a1b		1a1b		1a1b			
Conventional Free Air Thermal Current Ith [A]		2		5		5		5		5		5		5		5		5		5			
Rating Use Current [A]		Category AC-15 (AC Contactors Coil Switching Make Contact/Break Contact)		AC24 V		2 (0.5)/2 (0.5)		2 (0.5)/3 (0.5)		2 (0.5)/3 (0.5)		2 (0.5)/3 (0.5)		2 (0.5)/3 (0.5)		2 (0.5)/3 (0.5)		2 (0.5)/3 (0.5)		2 (0.5)/3 (0.5)			
		AC120 V		2 (0.5)/2 (0.5)		2 (0.5)/3 (0.5)		2 (0.5)/3 (0.5)		2 (0.5)/3 (0.5)		2 (0.5)/3 (0.5)		2 (0.5)/3 (0.5)		2 (0.5)/3 (0.5)		2 (0.5)/3 (0.5)		2 (0.5)/3 (0.5)			
		AC240 V		1 (0.5)/1 (0.5)		1 (0.5)/2 (0.5)		1 (0.5)/2 (0.5)		1 (0.5)/2 (0.5)		1 (0.5)/2 (0.5)		1 (0.5)/2 (0.5)		1 (0.5)/2 (0.5)		1 (0.5)/2 (0.5)		1 (0.5)/2 (0.5)			
		AC550 V		0.3 (0.3)/0.3 (0.3)		0.3 (0.3)/0.3 (0.3)		0.3 (0.3)/0.3 (0.3)		0.5 (0.5)/1 (0.5)		0.5 (0.5)/1 (0.5)		0.5 (0.5)/1 (0.5)		0.5 (0.5)/1 (0.5)		0.5 (0.5)/1 (0.5)		0.5 (0.5)/1 (0.5)			
Category DC-13 (DC Contactors Coil Switching)		DC24 V		0.5 (0.3)		1 (0.3)		1 (0.3)		1 (0.3)		1 (0.3)		1 (0.3)		1 (0.3)		1 (0.3)		1 (0.3)			
DC110 V		0.2 (0.2)		0.2 (0.2)		0.2 (0.2)		0.2 (0.2)		0.2 (0.2)		0.2 (0.2)		0.2 (0.2)		0.2 (0.2)		0.2 (0.2)		0.2 (0.2)			
DC220 V		0.1 (0.1)		0.1 (0.1)		0.1 (0.1)		0.1 (0.1)		0.1 (0.1)		0.1 (0.1)		0.1 (0.1)		0.1 (0.1)		0.1 (0.1)		0.1 (0.1)			
Minimum Applicable Load Level		20 V 5 mA		20 V 5 mA		20 V 5 mA		20 V 5 mA		20 V 5 mA		20 V 5 mA		20 V 5 mA		20 V 5 mA		20 V 5 mA		20 V 5 mA			
Terminal Screw Size		M3.5		M3.5		M3.5		M4		M4		M4		M4		M4		M4		M4			
Terminal-Compatible		Wire Size [mm ²] φ1.6, 0.75 to 2.5 Crimp Lug Size 1.25-3.5 to 2-3.5		φ1.6, 0.75 to 2.5 1.25-3.5 to 2-3.5		φ1.6, 1.25 to 2 1.25-3.5 to 2-3.5		φ1.6, 1.25 to 2 1.25-4 to 2-4, 5.5-S4		φ1.6, 1.25 to 2 1.25-4 to 2-4, 5.5-S4		φ1.6, 1.25 to 2 1.25-4 to 2-4, 5.5-S4		φ1.6, 1.25 to 2 1.25-4 to 2-4, 5.5-S4		φ1.6, 1.25 to 2 1.25-4 to 2-4, 5.5-S4		φ1.6, 1.25 to 2 1.25-4 to 2-4, 5.5-S4		φ1.6, 1.25 to 2 1.25-4 to 2-4, 5.5-S4			
Operating Characteristic Curve Page		153							156			156			156								
Vibration Resistance (Vibration and Malfunction Resistance Performance)		10 to 55Hz 19.6m/s ²							10 to 55Hz 19.6m/s ²														
Trip Free		○		○		○		○		○		○		○		○		○		○			
Reset Method		Manual/Automatic Switchable		Manual/Automatic Switchable		Manual/Automatic Switchable		Manual/Automatic Switchable		Manual/Automatic Switchable		Manual/Automatic Switchable		Manual/Automatic Switchable		Manual/Automatic Switchable		Manual/Automatic Switchable		Manual/Automatic Switchable			
Operation Indicator (Lever Display)		○		○		○		○		○		○		○		○		○		○			
Manual Tripping Check		○		○		○		○		○		○		○		○		○		○			
Frame of the Combined Magnetic Contactor		T10, T12, T20 T12, T20 T20		T21, T25, T35, T50		T35, T50 T50		T65, T80, T100		T80, T100 T100		N125, N150 N150		N180, N220 N220		N300, N400 N400		N600, N800					
With Saturable Reactor [See Page 146]		With 2-Element (TH-□SR)		○ (TH-T18SR)		○ (TH-T25SR)		○ (TH-T50SR)		○ (TH-T65SR)		○ (TH-T100SR)		○ (TH-N120SR)		○ (TH-N120TASR)		○ (TH-N220□SR)		○ (TH-N400□SR)		○ (TH-N600SR)	
With 3-Element (2E) (TH-□KPSR)		—		○ (TH-T25KPSR)		○ (TH-T50KPSR)		○ (TH-T65KPSR)		○ (TH-T100KPSR)		○ (TH-N120KPSR)		○ (TH-N120TAKPSR)		○ (TH-N220□KPSR)		○ (TH-N400□KPSR)		○ (TH-N600KPSR)			
Quick Trip Type [See Page 147]		With 2-Element (TH-□FS)		△ (TH-T18FSK)		△ (TH-T25FSK)		△ (TH-T50FSK)		△ (TH-T65FSK)		△ (TH-T100FSK)		—		—		—		—		—	
With 3-Element (2E) (TH-□FSKP, KF)		—		△ (TH-T18FSKP)		△ (TH-T25FSKP)		△ (TH-T50FSKP)		△ (TH-T65FSKP)		△ (TH-T100FSKP)		—		—		—		—		—	
Live Part Protection Cover		(Standard Equipment)		(Standard Equipment)		(Standard Equipment)		○ (UN-CZ605)		—		—		—		—		—		—		—	
Reset Release		○ (UT-RR□5)		○ (UN-RR□0)		○ (UN-RR□0)		○ (UN-RR□6)		○ (UN-RR□6)		○ (UN-RR□6)		○ (UN-RR□6)		○ (UN-RR□6)		○ (UN-RR□6)		○ (UN-RR□6)		○ (UN-RR□6)	
Operation Indicator Lamp		○ (UN-TL12)		○ (UN-TL20)		○ (UN-TL20)		○ (UN-TL60)		○ (UN-TL60)		○ (UN-TL60)		○ (UN-TL60)		○ (UN-TL60)		○ (UN-TL60)		○ (UN-TL60)		○ (UN-TL60)	
Independent/IEC 35 mm Rail Mounting Unit		○ (UT-HZ18)		○ (UN-RM20)		—		—		—		—		—		—		—		—		—	
Misoperation Prevention Cover		—		○ (UN-CV203)		○ (UN-CV203)		○ (UN-CV603)		○ (UN-CV603)		○ (UN-CV603)		○ (UN-CV603)		○ (UN-CV603)		○ (UN-CV603)		○ (UN-CV603)		○ (UN-CV603)	

Note 1. All model names come with ambient temperature compensation device.

Note 2. ○ indicates standard type (standard equipment), ◯ indicates semi-standard type, △ indicates special products and - indicates products outside production range.

Note 3. Use TH-N600(KP) in combination with current transformer for measuring instruments (rated secondary load of 15 VA or more). The recommended model names are CW-15LM or CW-15L for 250, 330 and 500 A, and CW-40LM for 660 A. The ratio of current transformation is as shown in the heater designation field in the table.

Note 4. The power consumption indicates the amount consumed by the heater element only. (The current transformer consumption amounts of the N220 to N600 frames are not included.)

5.2 Contact Rating

● Main circuit specifications... as shown on page136 ● Specifications of the control circuit (contact) ● The contact rating is as shown in the following table

Frame		T18		T25, T50		T65, T100, N120 to N600	
Contact		Break Contact	Make Contact	Break Contact	Make Contact	Break Contact	Make Contact
Conventional Free Air Thermal Current Ith [A]		2	2	5	5	5	5
Class AC-15 Rated Operating Current [A]	AC24V	2 (0.5)	2 (0.5)	3 (0.5)	2 (0.5)	3 (0.5)	2 (0.5)
	AC120V	2 (0.5)	2 (0.5)	3 (0.5)	2 (0.5)	3 (0.5)	2 (0.5)
	AC240V	1 (0.5)	1 (0.5)	2 (0.5)	1 (0.5)	2 (0.5)	1 (0.5)
Class DC-13 Rated Operating Current [A]	AC550V	0.3 (0.3)	0.3 (0.3)	0.3 (0.3)	0.3 (0.3)	1 (0.5)	0.5 (0.5)
	DC24V	0.5 (0.3)	0.5 (0.3)	1 (0.3)	1 (0.3)	1 (0.3)	1 (0.3)
	DC110V	0.2 (0.2)	0.2 (0.2)	0.2 (0.2)	0.2 (0.2)	0.2 (0.2)	0.2 (0.2)
	DC220V	0.1 (0.1)	0.1 (0.1)	0.1 (0.1)	0.1 (0.1)	0.1 (0.1)	0.1 (0.1)

Note 1. The withstand voltage is AC2500 V for 1 minute.

Note 2. The contact arrangement is 1a1b.

Note 3. If the coil current of the DC operated magnetic contactor (SD) exceeds 0.2 A at DC110 V or 0.1 A at DC220 V (SD-N125 or higher), conduct through the SR or SRD contactor relay. (Refer to the figure on the right)

Note 4. The minimum available voltage and current level in a clean atmosphere is 20 V 5 mA.

Note 5. The value in parentheses is the rating during auto reset.

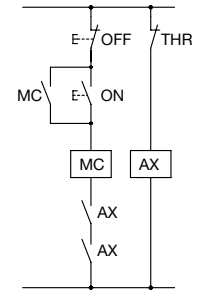

MC : SD Type
AX : SRD Type
THR : TH Type

5.3 Operating Properties (Standard Value)

The operating properties of the thermal overload relays are specified as shown in the table below according to the standards.

Standard	Conditions	Operation in Balanced Circuit				Operation in Unbalanced Circuit		Ambient Temperature
		Limit Operations		Operation During Overload	Operation During Constraint	Non-Operation	Operation	
		A (Cold Start)	B (Continued From A)	C (Hot Start)	D (Cold Start)	A (Cold Start)	B (Continued From A)	
JIS C8201-4-1	Multiple of Settling Current	1.05	1.2	1.5	7.2	2-Pole 1.0 1-Pole 0.9	2-Pole 1.15 1-Pole 0	20°C
	Operating Time	Non-Operation (2 Hours)	Within 2 Hours	(5) Less Than 2 Minutes	(5) $T_p \leq 5$ Seconds	Non-Operation (2 Hours)	Within 2 Hours	
				(10A) Less Than 2 Minutes	(10A) $2 < T_p \leq 10$ Seconds			
				(10) Less Than 4 Minutes	(10) $4 < T_p \leq 10$ Seconds			
				(20) Less Than 8 Minutes	(20) $6 < T_p \leq 20$ Seconds			
IEC 60947-4-1	Multiple of Settling Current	1.05	1.2	1.5	7.2	2-Pole 1.0 1-Pole 0.9	2-Pole 1.15 1-Pole 0	20°C
	Operating Time	Non-Operation (2 Hours)	Within 2 Hours	(10A) Less Than 2 Minutes	(10A) $2 < T_p \leq 10$ Seconds	Non-Operation (2 Hours)	Within 2 Hours	
				(10) Less Than 4 Minutes	(10) $4 < T_p \leq 10$ Seconds			
				(20) Less Than 8 Minutes	(20) $6 < T_p \leq 20$ Seconds			
				(30) Less Than 12 Minutes	(30) $9 < T_p \leq 30$ Seconds			
JEM 1356	Multiple of Settling Current	1.05	1.2	1.5	7.2	2-Pole 1.0 1-Pole 0.9	2-Pole 1.15 1-Pole 0	20°C
	Operating Time	Non-Operation (2 Hours)	Within 2 Hours	(Quick) Within 4 Minutes	(Quick) $T_p \leq 5$ Seconds	Non-Operation (2 Hours)	Within 2 Hours	
				(Standard) Within 8 Minutes	(Standard) $2 \leq T_p \leq 15$ Seconds			
				(Delay) Within 12 Minutes	(Delay) $9 \leq T_p \leq 30$ Seconds			

Note 1. It shows the case of the thermal overload relay with ambient temperature compensation and open phase detection.

Note 2. T_p shows the operating time while restrained.

Note 3. The operating time field () of the operation during overload and constraint represents the trip class in JIS and IEC, and type in JEM.

5.4 Selection and Application

● Selecting Thermal Overload Relays

The principles in the selection of the thermal overload relay are that its operating characteristic curve falls below the thermal properties (overcurrent - service lifetime properties) of the motor, and exceeds the startup properties (startup current - time properties) curve of the motor. Judge the suitability of the thermal properties and starting properties of the motor by superposing them on the operating characteristic curve (see page 153) of the thermal overload relay. (Refer to Figure 4 on page 143)

Motor, Running, Protection Conditions, etc.	Selection	Applicable Thermal Overload Relays	
		With 2-Element	With 3-Element (2E)
Standard Start, Stop (Low Frequency)	Standard Thermal Overload Relays	TH-□Type	TH-□KP Type
Fan, blower, etc. with long start-up time	Thermal Overload Relays With Saturable Reactor	TH-□SR Type	TH-□KPSR Type
Submersible motor and compressor motor with short allowable constraint time	Quick-acting Characteristics Thermal Overload Relays	TH-□FS Type	TH-□FSPK Type
Inching, High Frequency Intermittent Running	Although unnecessary trips may be avoided by the thermal overload relay with a saturable reactor to provide the adequate protection, detailed consideration is required	Consideration Required	Consideration Required
For Open-Phase Protection	Thermal Overload Relays With 3-Element (2E)	—	TH-□KP Type
Reverse-Phase and Open-Phase Protection Dual Use	Electronic Motor Protection Relays (3E)	—	(ET-□ Type)

Note 1. For more information on the startup time of motors and application of thermal overload relays, refer to page 140.

● Thermal Overload Relay Heater Designation Selection Table

Guidelines for the selection of general thermal overload relays are shown in the following table.

Voltage Motor Capacity [kW]	Three-Phase Motors								Single-Phase Motors				Voltage Capacity [kW]
	200 to 220V	230 to 240V	346 to 350V	380V	400 to 440V	460 to 500V	550 to 600V	660V	100 to 110V	115 to 120V	200 to 220V	230 to 240V	
0.03	0.24A	0.24A	—	—	—	—	—	—					0.03
0.035	0.35A	0.24A	0.24A	0.24A	—	—	—	—	1.7A		0.9A		0.035
0.05	0.35A	0.35A	0.24A	0.24A	0.24A	—	—	—					0.05
0.06 to 0.065	0.5A	0.35A	0.35A	0.24A	0.24A	0.24A	—	—	2.5A		1.3A		0.06 to 0.065
0.07	0.5A	0.5A	0.35A	0.35A	0.35A	0.24A	—	—					0.07
0.09	0.7A	0.7A	0.35A	0.35A	0.35A	0.24A	0.24A	—					0.09
0.1	0.7A	0.7A	0.35A	0.35A	0.35A	0.35A	0.24A	—	3.6A		1.7A		0.1
0.12	0.9A	0.7A	0.5A	0.5A	0.5A	0.35A	0.24A	—		3.6A		2.1A	0.12
0.15	0.9A	0.9A	0.7A	0.7A	0.5A	0.5A	0.35A	—	5A		2.5A		0.15
0.18	1.3A	0.9A	0.7A	0.7A	0.7A	0.5A	0.5A	—	5A	5A		2.5A	0.18
0.2	1.3A	0.9A	0.7A	0.7A	0.7A	0.7A	0.5A	—	5A		2.5A		0.2
0.25	1.7A	1.3A	0.9A	0.9A	0.7A	0.7A	0.5A	—	6.6A	6.6A	3.6A	3.6A	0.25
0.3	1.7A	1.3A	0.9A	0.9A	0.9A	0.9A	0.7A	—	6.6A		3.6A		0.3
0.37 to 0.4	2.1A	2.1A	1.3A	1.3A	1.3A	0.9A	0.7A	—	9A	9A	5A	5A	0.37 to 0.4
0.55	2.5A	2.5A	1.7A	1.7A	1.3A	1.3A	0.9A	—	11A	11A	5A	6.6A	0.55
0.75	3.6A	3.6A	2.1A	2.1A	1.7A	1.7A	1.3A	1.3A	15A	15A	6.6A	9A	0.75
1.0	5A	5A	2.5A	2.5A	2.5A	2.1A	1.7A	1.7A					1.0
1.1	5A	5A	3.6A	2.5A	2.5A	2.1A	1.7A	1.7A	22A	22A	9A	9A	1.1
1.3	6.6A	5A	3.6A	3.6A	2.5A	2.5A	2.1A	2.1A					1.3
1.5	6.6A	6.6A	3.6A	3.6A	3.6A	2.5A	2.5A	2.1A	29A	22A	15A	11A	1.5
2.2	9A	9A	5A	5A	5A	3.6A	3.6A	3.6A					2.2
3	11A	11A	6.6A	6.6A	6.6A	5A	5A	3.6A					3
3.7 to 4	15A	15A	9A	9A	6.6A	6.6A	5A	5A		35A		15A	3.7 to 4
5.5	22A	22A	15A	11A	11A	9A	9A	6.6A		54A		29A	5.5
7.5	29A	29A	15A	15A	15A	11A	9A	9A		82A		42A	7.5
9	35A	29A	22A	22A	15A	15A	11A	11A		105A		54A	9
11	42A	42A	22A	22A	22A	22A	15A	15A					11
15	54A	54A	35A	29A	29A	22A	22A	15A					15
18.5 to 19	67A	67A	42A	35A	35A	29A	22A	22A					18.5 to 19
22	82A	82A	54A	42A	42A	35A	29A	22A					22
25	82A	82A	54A	54A	54A	35A	35A	29A					25
30	105A	105A	67A	54A	54A	42A	42A	35A					30
37	125A	125A	82A	67A	67A	54A	54A	42A					37
45	150A	150A	105A	82A	82A	67A	54A	42A					45
55 to 60	180A	180A	125A	105A	105A	82A	67A	67A					55 to 60
75	250A	250A	150A	125A	125A	105A	105A	82A					75
90	330A	330A	180A	150A	150A	125A	105A	105A					90
110	330A	330A	250A	180A	180A	150A	125A	105A					110
132	500A	500A	250A	250A	250A	180A	150A	150A					132
150 to 160	500A	500A	330A	250A	250A	250A	180A	180A					150 to 160
185	660A	500A	330A	330A	330A	250A	250A	180A					185
200	660A	660A	500A	330A	330A	330A	250A	180A					200
220	660A	660A	500A	500A	500A	330A	250A	250A					220
250	—	—	500A	500A	500A	330A	330A	250A					250
300 to 315	—	—	660A	500A	500A	500A	330A	330A					300 to 315
370 to 400	—	—	—	660A	660A	500A	500A	500A					370 to 400

Note 1. The table above shows the selection of heater designation based on the full-load current value of the 4-pole standard three-phase motor and single-phase motor manufactured by Mitsubishi Electric.

When ordering by motor capacity, determine the heater designation of the thermal overload relay with this table. Specify the voltage and capacity accurately.

Note 2. If the number of poles in the three-phase motor is different, or in the case of special motors, the full-load current value may be different.

In such a case, specify by the heater designation upon investigating the full-load current of the motor.

Note 3. For single-phase motors, the full-load current varies depending on the start-up and running methods. Therefore, treat the values in the above table as guidelines, and specify the appropriate heater designation upon checking the full-load current for actual use. For single-phase motors, connect as shown in the figure below.

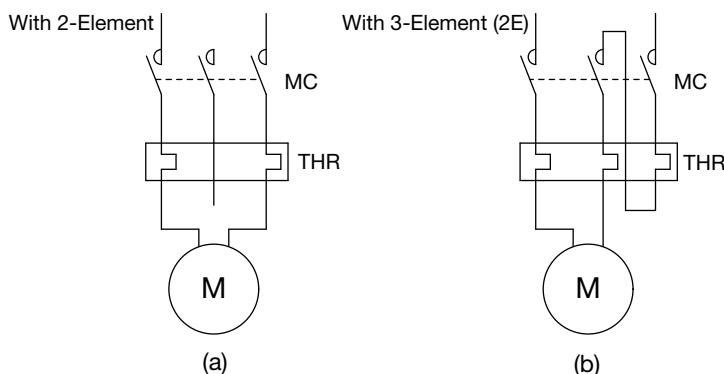

Connecting Thermal Overload Relays to a Single-Phase Motor

5.5 Structure

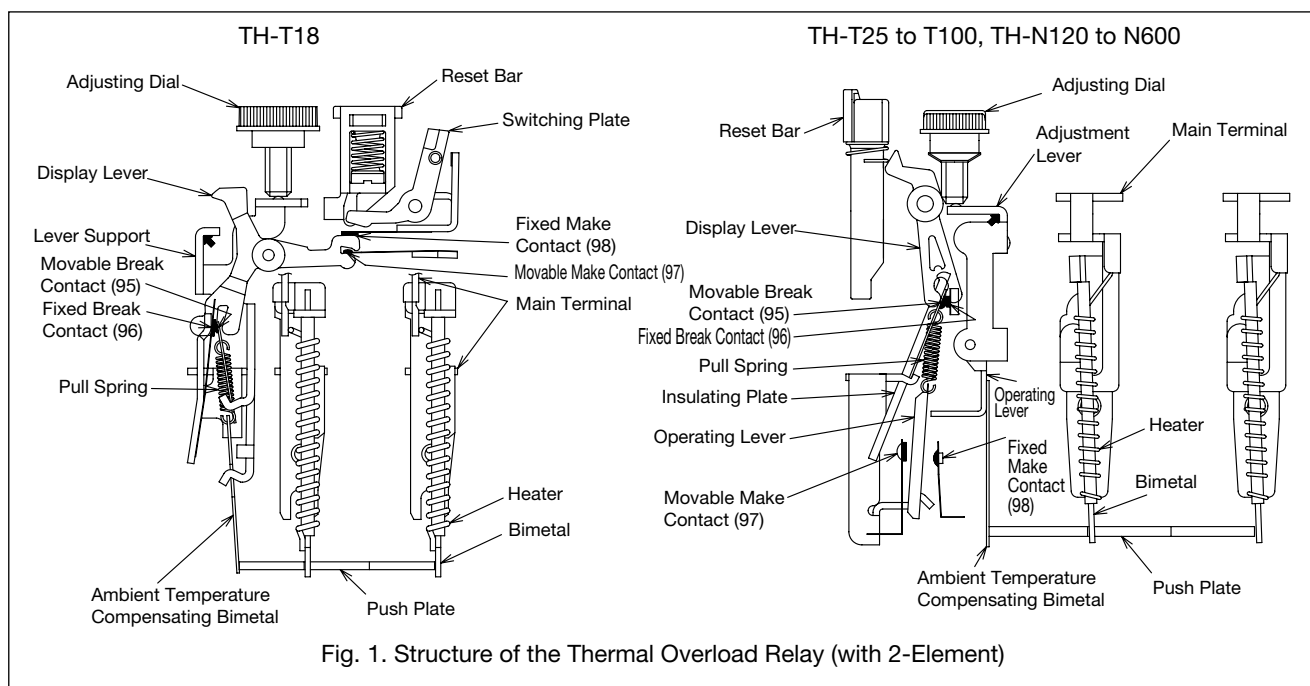

Fig. 1. Structure of the Thermal Overload Relay (with 2-Element)

● Reset Method

All models of TH-T/N Series thermal overload relays have a structure that allows manual/automatic reset switching. The factory default (standard) is manual reset.

● Structure of the Thermal Overload Relay With Open-Phase Protection Function

The push plate of the thermal overload relay with overload and open-phase protection (TH-□KP) has a differential amplification mechanism that transmits the action of the bimetal to the contact mechanism as shown in Figure 2. Its design is suitable for protection during open phase.

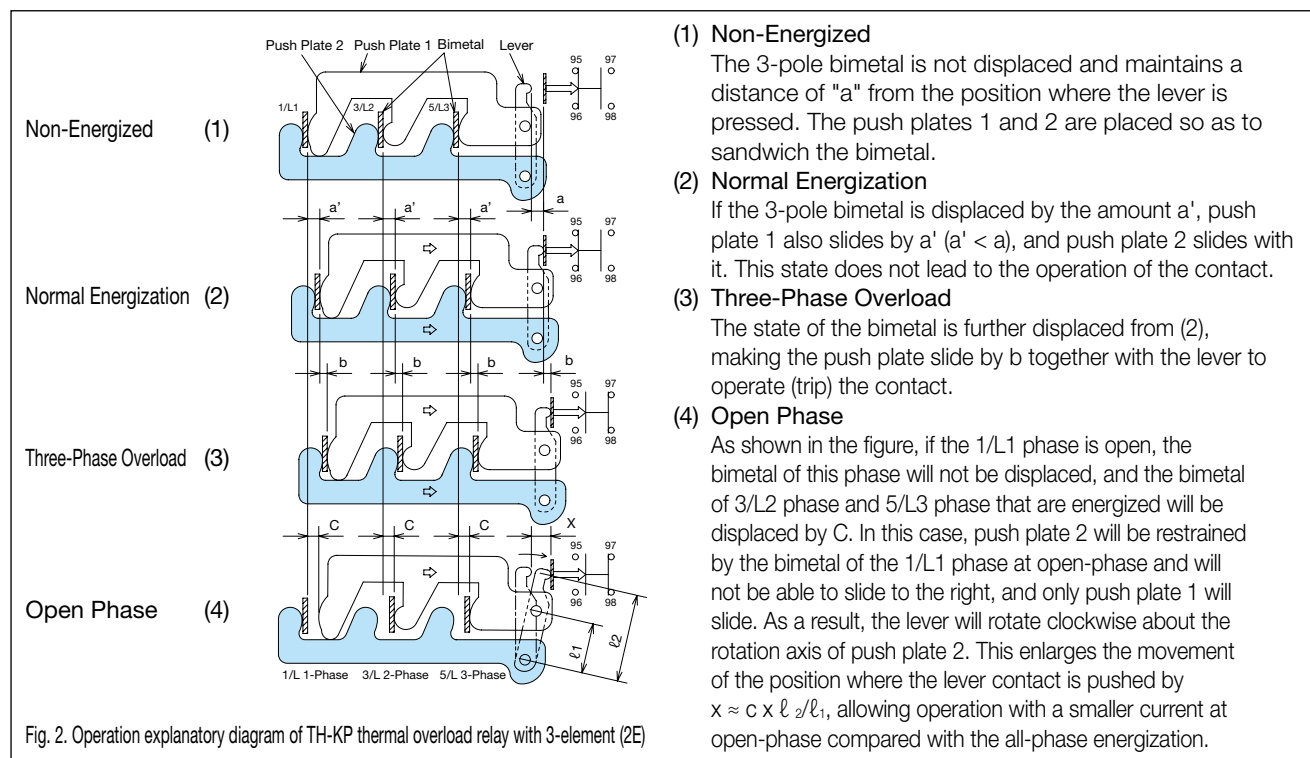

Fig. 2. Operation explanatory diagram of TH-KP thermal overload relay with 3-element (2E)

(1) Non-Energized

The 3-pole bimetal is not displaced and maintains a distance of "a" from the position where the lever is pressed. The push plates 1 and 2 are placed so as to sandwich the bimetal.

(2) Normal Energization

If the 3-pole bimetal is displaced by the amount a' , push plate 1 also slides by a' ($a' < a$), and push plate 2 slides with it. This state does not lead to the operation of the contact.

(3) Three-Phase Overload

The state of the bimetal is further displaced from (2), making the push plate slide by b together with the lever to operate (trip) the contact.

(4) Open Phase

As shown in the figure, if the 1/L1 phase is open, the bimetal of this phase will not be displaced, and the bimetal of 3/L2 phase and 5/L3 phase that are energized will be displaced by C . In this case, push plate 2 will be restrained by the bimetal of the 1/L1 phase at open-phase and will not be able to slide to the right, and only push plate 1 will slide. As a result, the lever will rotate clockwise about the rotation axis of push plate 2. This enlarges the movement of the position where the lever contact is pushed by $x \approx c \times l_2 / l_1$, allowing operation with a smaller current at open-phase compared with the all-phase energization.

5.6 Precautions for Use

● Model Name Identification by Mounting Method

Note 1. T25, T65 and N120 can be independently mounted as standard.

Note 2. T18, T50, T100, N120TA, N220RH and N400RH are for magnetic starters. (No Independent Mounting)
N120TAHZ, N220HZ and N400HZ are for independent mounting.

Note 3. For T18, independent mounting and IEC 35 mm rail mounting may be enabled by combining with UT-HZ18.
For T25, IEC 35 mm rail mounting may be enabled by combining with UN-RM20.

● Disassembly

The Thermal Overload Relays are adjusted at the time of assembly. Do not disassemble it.
Do not use with the terminal removed, as the properties may change.

● Ambient Temperature Compensation

The TH-T/N type Thermal Overload Relays are adjusted with the Magnetic Starters in the standard box (the MS type) relative to the ambient temperature of 20°C (The temperature on the control board of the MSO type Magnetic Starters is 35°C). The ambient temperature compensator is mounted on the TH-T/N type Thermal Overload Relays. Therefore, the ambient temperature less affects the operational characteristic change. The minimum operating current change according to the ambient temperature change relative to the ambient temperature of 20°C (the temperature on the control board of 35°C) generally depends on the characteristics in the diagrams 1 and 2. The Thermal Overload Relays have a characteristic that the operating current becomes high when the ambient temperature is low and becomes low when the ambient temperature is high. If the ambient temperature of the installation site is significantly different from 20°C (the temperature on the control board of 35°C), the setting current of the Thermal Overload Relays needs to be corrected as shown in diagrams 1 and 2. In addition, note that the compensation factor has a characteristic to be the minimum scale>middle scale>maximum scale at the adjustment knob location. (Note that the Thermal Overload Relays may operate at a current of less than 100% stabilized current if in use at temperatures exceeding the allowable working temperature of 40°C (55°C).)

Fig. 3.1 Ambient temperature compensation curve (T18 frame)

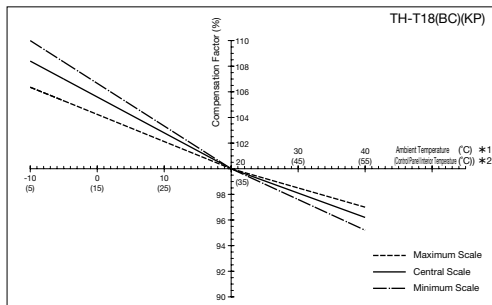

Fig. 3.2 Ambient temperature compensation curve (T25/T50/T65/T100 frame)

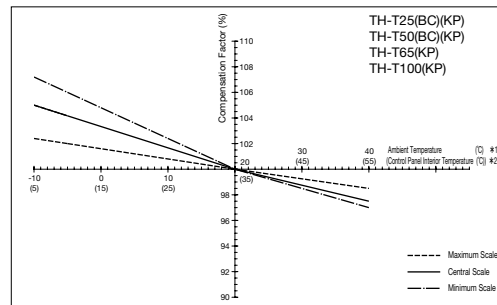

Fig. 3.3 Ambient temperature compensation curve (N120 frame)

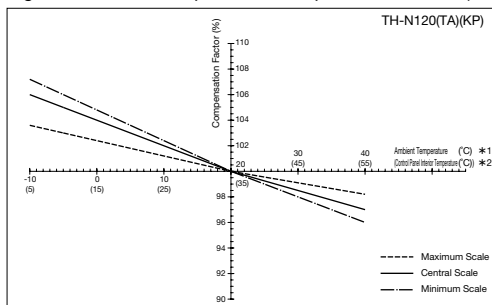

Fig. 3.4 Ambient temperature compensation curve (N220/N400 frame)

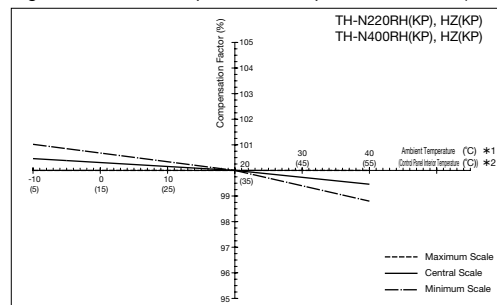
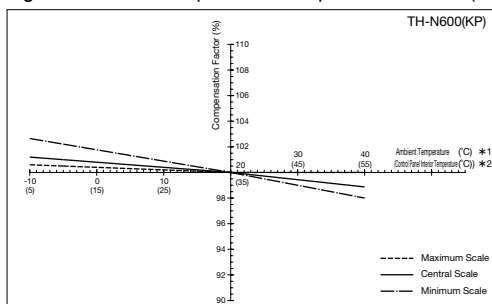

Fig. 3.5 Ambient temperature compensation curve (N600 frame)



Compensation factor: Percentage of the minimum operating current at the ambient temperature of 20°C (the temperature on the control board of 35°C)

<Compensation procedure of setting current>
Determine the compensation factor of the working ambient temperature according to the curves in diagrams 3.1 and 3.5 and use the value of all load currents of the motor divided by the determined compensation factor as the stabilization value.
(Example: The ambient temperature compensation factor for TH-T50 at the ambient temperature of 40°C (the temperature on the control board of 55°C) is 97% at the minimum scale according to diagram 3.2. If the motor rated current is 43A, the stabilization value is 44.3A (=43/0.97).)

Note 1. The ambient temperature applied to MS type indicates the outside temperature of the box.

Note 2. The temperature including the temperature increase on the control board applied to the MSO type is indicated.

Note 2. When the thermal overload relay is independently mounted, divide the settling value obtained in Figure 3.1 to 3.5 by the compensation factors in the table below.

● Compensation factor when using the thermal overload relay independently

Model Name	Independent Thermal Overload Relays TH-□
TH-T18(BC)(KP) 0.12 to 2.5A	1.04
TH-T18(BC)(KP) 3.6A	1.05
TH-T18(BC)(KP) 5 to 15A	1.06
TH-T25(BC)(KP)	1.06
TH-T65(KP)	1.05

Model Name	Independent Thermal Overload Relays TH-□
TH-N120(KP) 42A 54A	1.08
TH-N120(KP) 67A 82A	1.16
TH-N220(KP)/N400(KP)	1.01
TH-N600(KP)	1.02

● Connecting Electric Wire Size And Operating Current

The minimum operating current of TH-T/N has been adjusted by the standard wire size as shown in the table below. If the electric wire is thicker or thinner than this standard electric wire size, the operating current becomes high or low, respectively. Therefore, correct the stabilized current (divide it by the change rate of the minimum operating current) to use a size different from the standard connecting electric wire size.

● Connecting Electric Wire Size and Minimum Operating Current

Model Name	Heater Designation [A]	Standard Electric Wire Size [mm ²]	Connecting Electric Wire Size [mm ²]	Change Rate of Minimum Operating Current [%]
TH-T18(KP)	0.12 to 15	2	1.25	98
TH-T25(KP)			2.5	103
TH-T25(KP)	0.24 to 11	3.5	2	97
TH-T25(KP)	15, 22		6	104
TH-T50(KP)	29	8	5.5	96
	35		14	104
	42	14	8	95
TH-T65(KP)	15	3.5	2	95
	22, 29	5.5	5.5	105
			8	96
	35	8	5.5	95
TH-T65(KP)	42	14	14	105
			8	95
	54	22	22	104
			14	96
			30	104

Model Name	Heater Designation [A]	Standard Electric Wire Size [mm ²]	Connecting Electric Wire Size [mm ²]	Change Rate of Minimum Operating Current [%]
TH-T100(KP)	67	22	14	97
	82	38	30	103
TH-N120(KP)	42	14	8	95
	54, 67	22	22	104
			14	96
	82	38	30	97
TH-N120TA(KP)	105	60	38	97
			60	103
	125	60	50	98
			80	103

5

● Combination With No-Fuse Breaker (Protection Coordination)

Magnetic starters are responsible for the starting and stopping of motors, and protection from burnout due to overload, constraint or open-phase. Short-circuit protection devices such as no-fuse breakers are responsible for the current larger than the interruption capability of the magnetic starter caused by a short circuit, etc.

Properly performing these allocations is called protection coordination and the principles are as follows (see Figure 4)

- (1) The combined operating properties of the thermal overload relay and no-fuse breaker must be on the lower side of the thermal properties of the motor, which are on the upper side (right side) of the start-up properties and full-load current of the motor.
- (2) For overload current of less than the constraint (startup) current, the thermal overload relay must operate earlier than the no-fuse breaker.
- (3) The no-fuse breaker must operate if the current is larger than the interruption capability of the magnetic starter.
- (4) The no-fuse breaker should operate if the current is less than the overload resistance of the magnetic starter.
- (5) The operating properties of the no-fuse breaker must be lower than the allowable current - time properties of the wire.

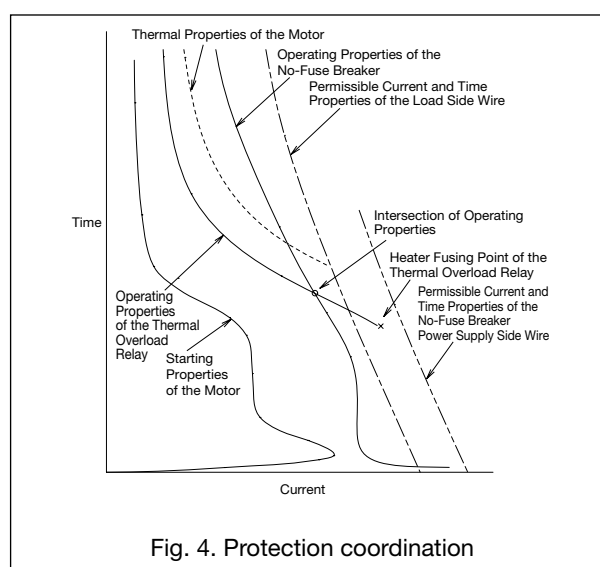

Fig. 4. Protection coordination

For more information, refer to the catalog and technical documents of the no-fuse breaker.

● Handling (Precautions)

- (1) When restarting the tripped thermal overload relay, remove the cause of the trip.
When the automatic reset method is used, in order to prevent the motor from automatically restarting due to reset, implement measures such as adopting a self-retaining circuit. Regardless of the method, the resettable time will be from about 10 seconds to 10 minutes depending on the heating temperature of the bimetal.
Furthermore, to cool the bimetal to the surrounding temperature, use equipment such as fans for about 30 minutes.
- (2) Never touch the inside of the thermal overload relay.
- (3) The heater wire of the thermal overload relay may blow before tripping if it is charged with a current of 13 times higher than the rating.
- (4) The reset method is changed as follows.

Changing the reset method of TH-T18

- Manual→automatic switching method:
After removing the stopper by cutting it with a nipper or the like, slide the switching plate to the right and align it with A as shown in Figure 5.
(In the state as shown in Figure 6.2)
- Automatic→manual switching method:
Slide the switching plate to the left to align with H.
(In the state as shown in Figure 6.1)

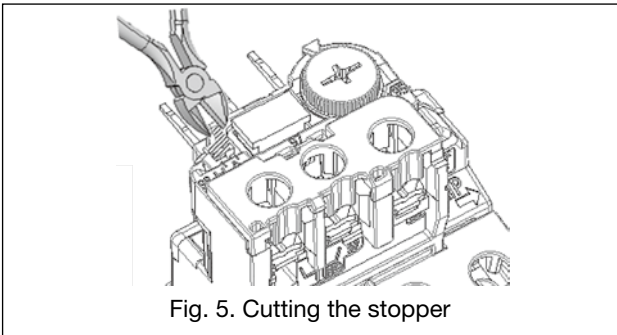

Fig. 5. Cutting the stopper

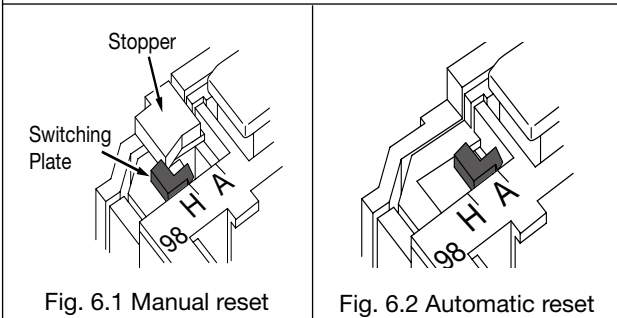

Fig. 6.1 Manual reset

Fig. 6.2 Automatic reset

Note 1. Take precautions as follows when cutting off the stopper.

- Be careful not to let fragments enter the eyes.

(5) Manual tripping

Manual tripping is enabled by inserting a screwdriver or the like into the display window in manual reset. (Fig. 10)

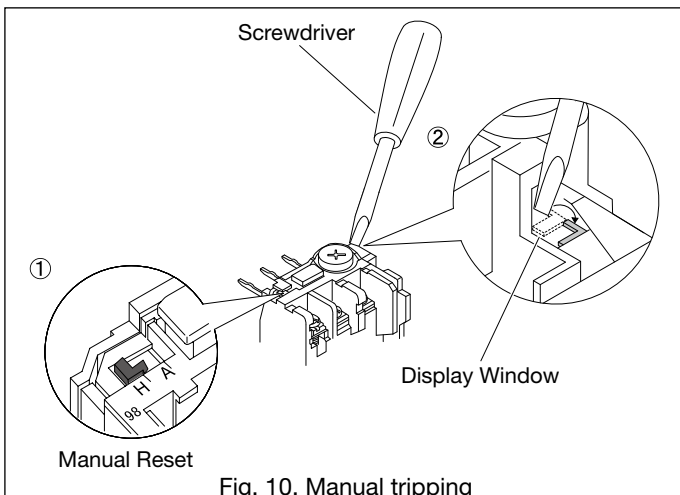

Fig. 10. Manual tripping

Note. For TH-T18, do not perform manual tripping in the automatic reset mode, as this leads to internal component failure. When performing a sequence check, be sure that the automatic reset is switched to manual reset.

Changing the reset method of TH-T25 to T100, TH-N120 to N600

- Manual→automatic switching method:
After cutting off the stopper on the tip of the reset bar, fully push it in, then rotate it in the direction of A. (Figs. 7, 8)
- Automatic→manual switching method:
Rotate the reset bar in the direction of H, to pop out the reset bar. (Fig. 9)

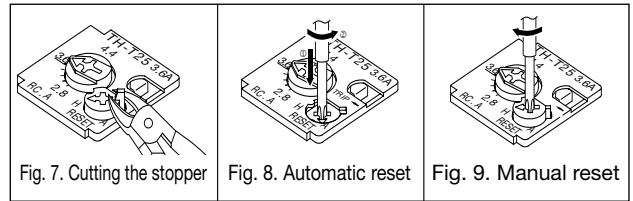

Fig. 7. Cutting the stopper

Fig. 8. Automatic reset

Fig. 9. Manual reset

Note 1. Take precautions as follows when cutting off the stopper on the tip of the reset bar.

- Make sure that segments do not enter from the display window.
The display lever may stop moving.
Block the display window when cutting off the stopper to prevent segments from entering it.
- Be careful not to let fragments enter the eyes.

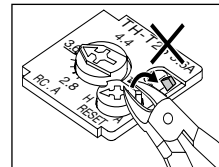

(6) Precautions When Combining With the Magnetic Contactor

For the assembling method and precautions when using in combination with the thermal overload relay and magnetic contactor, refer to page 231.

5.8 Thermal Overload Relays with Saturable Reactor TH-□(KP)SR

As the standard thermal overload relay operates at startup, suitable protective properties may not be obtained for motors that take a long time to start, such as those that are started with a large inertial load.

The thermal overload relay with saturable reactor has a structure with a small reactor with an iron-containing core connected in parallel with the heater. It causes little change to the operating properties in the current range of up to about 200% of settling current, and in the current range beyond that, the iron core of the reactor is saturated to increase the shunt current to the reactor and limit the current to the heater in order to increase the operating time limit.

In addition, it helps achieve protection coordination with a low voltage circuit breaker.

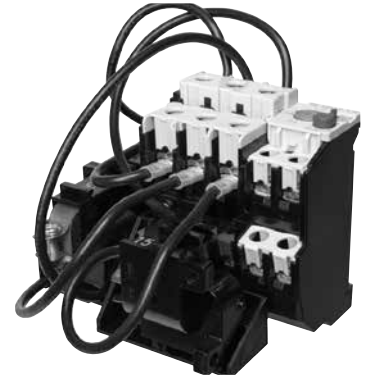

TH-T25KPSR

● Application

For selection of heater designation for the capacity of the standard three-phase motor, refer to pages 48 and 139. Selection guidelines for motor start-up time are shown on page 140. The manufactured model name, heater designation and combined magnetic contactor frame are indicated in the table below.

● Manufactured model name, heater designation and combined magnetic contactor frame (with saturable reactor)

Model Name	With 2-Element	For Magnetic Starters	For Non-Reversing For Reversing	TH-T18SR	TH-T18HZSR	TH-T25SR	TH-T50SR	TH-T65SR	TH-T100SR	TH-N120SR	TH-N120TASR	TH-N220RHSR	TH-N400RHSR	TH-N600SR
		For Independent Mounting	(See Note 1)	(Note 5)	—	—	—	—	—	—	—	TH-N220HZSR	TH-N400HZSR	
	With 3-Element (2E)	For Magnetic Starters	For Non-Reversing For Reversing	—	TH-T25KPSR	TH-T50KPSR	TH-T65KPSR	TH-T100KPSR	TH-N120KPSR	TH-N120TAKP SR	TH-N220RHKP SR	TH-N400RHKP SR	TH-N600KPSR	
Operating Frequency Range [Hz]		50 to 60												
Heater Designation (Adjustment Range of Settling Current) [A]		0.24 (0.2 to 0.32) 0.35 (0.28 to 0.42) 0.5 (0.4 to 0.6) 0.7 (0.55 to 0.85) 0.9 (0.7 to 1.1) 1.3 (1 to 1.6) 1.7 (1.4 to 2) 2.1 (1.7 to 2.5) 2.5 (2 to 3) 3.6 (2.8 to 4.4) 5 (4 to 6) 6.6 (5.2 to 8) 9 (7 to 11) 11 (9 to 13) 15 (12 to 18)	0.24 (0.2 to 0.32) 0.35 (0.28 to 0.42) 0.5 (0.4 to 0.6) 0.7 (0.55 to 0.85) 0.9 (0.7 to 1.1) 1.3 (1 to 1.6) 1.7 (1.4 to 2) 2.1 (1.7 to 2.5) 2.5 (2 to 3) 3.6 (2.8 to 4.4) 5 (4 to 6) 6.6 (5.2 to 8) 9 (7 to 11) 11 (9 to 13) 15 (12 to 18)	29 (24 to 34) 35 (30 to 40) 42 (34 to 50)	15 (12 to 18) 22 (18 to 26) 29 (24 to 34) 35 (30 to 40) 42 (34 to 50) 54 (43 to 65)	67 (54 to 80) 82 (65 to 100) 95 (85 to 105)	42 (34 to 50) 54 (43 to 65) 67 (54 to 80) 82 (65 to 100)	42 (34 to 50) 54 (43 to 65) 67 (54 to 80) 82 (65 to 100)	105 (85 to 125) 125 (100 to 150)	82 (65 to 100) 125 (100 to 150) 150 (120 to 180) 180 (140 to 220) 210 (170 to 250)	105 (85 to 125) 125 (100 to 150) 150 (120 to 180) 180 (140 to 220) 210 (170 to 250) 250 (200 to 300) 330 (260 to 400)	105 (85 to 125) 125 (100 to 150) 150 (120 to 180) 180 (140 to 220) 210 (170 to 250) 250 (200 to 300) 330 (260 to 400)	250 (200 to 300) 330 (260 to 400) 500 (400 to 600) 660 (520 to 800) 800 (600 to 800)	
Frame of the Combined Magnetic Contactor		T10, T12, T20 T12, T20 T20	T21, T25 T35, T50	T35, T50 T50	T65, T80 T100	T80, T100 T100	N125, N150	N125, N150 N150	N180, N220 N220	N300, N400 N400	N600, N800			

Note 1. For TH-T18HZSR, independent mounting and IEC 35 mm rail mounting may be enabled by combining with UT-HZ18.

Note 2. Use TH-N600(KP)SR in combination with current transformer for measuring instruments (rated secondary load of 15 VA or more: recommended model names are CW-15LM, CW-15L or CW-40LM).

The alternating current ratio is as shown in the heater designation field in the table.

Note 3. The - mark in the model name field indicates that it is outside production range.

Note 4. TH-T18(HZ)SR, T25(KP)SR, T50(KP)SR with BC can also be manufactured.

However, TH-T50BC(KP)SR has no screw holder attached to the main circuit terminal (3-pole) on the power supply side.

Note 5. TH-T25BC (KP) SR with wiring streamlining terminal and S(D)-2 x T21 to T50BC cannot be combined. Order with MSO(D) (MSO(D)-2 x T21 to T50BC (KP) SR).

5.9 Quick-acting Characteristics Thermal Overload Relays TH-□FS(KP)

TH-FSKP and FS quick-acting characteristics thermal overload relays have quicker operation time than the standard TH type, so that they can be applied to motors such as submersible motors that have short allowable time during constraint.

Please note that TH-T□FSKP has 3 elements and can be used for 2E thermal, while TH-FS has 2 elements.

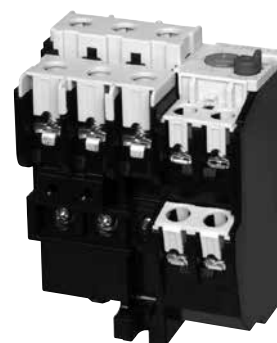

TH-T25FSKP

Application

The manufactured model name, heater designation and combined magnetic contactor frame are shown in the table below.

Model Name	With 2-Element	For Magnetic Starters	—	TH-T25FS	TH-T50FS	TH-T65FS	TH-T100FS
		For Independent Mounting	—	—	—	—	—
Model Name	With 3-Element (2E)	For Magnetic Starters	TH-T18FSKP	TH-T25FSKP	TH-T50FSKP	TH-T65FSKP	TH-T100FSKP
		For Independent Mounting	(See Note 1)	—	—	—	—
Operating Frequency Range [Hz]		0 (DC) to 400 (Note 4)					
Heater Designation (Adjustment Range of Settling Current) [A]		2.1(1.7 to 2.5) 3.6(2.8 to 4.4) 5(4 to 6) 6.6(5.2 to 8) 9(7 to 11) 11(9 to 13) 15(12 to 18)	2.1(1.7 to 2.5) 3.6(2.8 to 4.4) 5(4 to 6) 6.6(5.2 to 8) 9(7 to 11) 11(9 to 13) 15(12 to 18) 22(18 to 26)	29(24 to 34) 35(30 to 40) 42(34 to 50)	42(34 to 50) 54(43 to 65)	67(54 to 80) 82(65 to 93)	
(The --- line in the table on the right represents the correspondence between the magnetic contactor and frame to be combined)							
Trip Class (see page 138)		5					
Frame of the Combined Magnetic Contactor		T10, T12, T20 T12, T20 T20	T21, T25, T35, T50 T25, T35, T50	T35, T50 T50	T65, T80, T100	T80, T100 T100	

Note 1. For TH-T18FSKP, independent mounting and IEC 35 mm rail mounting may be enabled by combining with UT-HZ18.

For TH-T25FS(KP), IEC 35 mm rail mounting may be enabled by combining with UN-RM20.

Note 2. TH-T18FSKP, T25FS(KP), T50FS(KP) with BC can also be manufactured.

Note 3. The - mark in the model name field indicates that it is outside production range.

Note 4. It is standardly used at the commercial frequency of 50/60 Hz. Make sure that the protection coordination with motor characteristics is possible before use.

Outline Drawings

The same as the standard (with 2-element and 3-element (2E)). Refer to page 148.

5 TH-T/N Type Thermal Overload Relays

5.10 Outline Drawings/Contact Arrangements

■ T18 (The diagrams show models without "BC".)

TH-T18(BC)(KP)

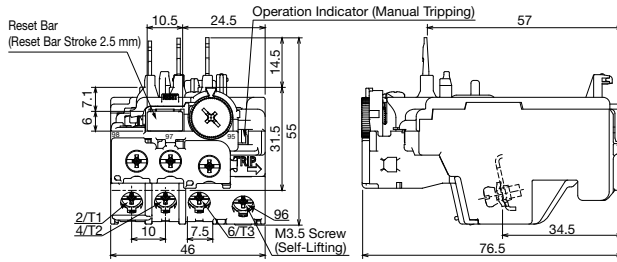
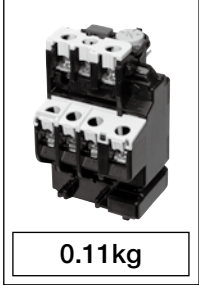

For combination with the following magnetic contactors
 TH-T18: S-T10, T12, T20 SD-T12, T20
 Independent use is possible by combining with the independent mounting unit UT-HZ18

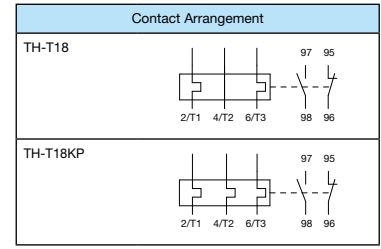

Model Name		Model Name	
TH-T18	0.12A to 11A 15 A	TH-T18BC	0.12A to 11A 15 A

TH-T18(HZ)SR

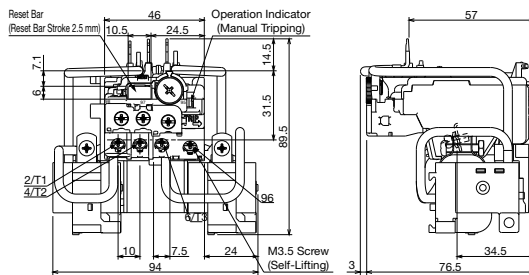
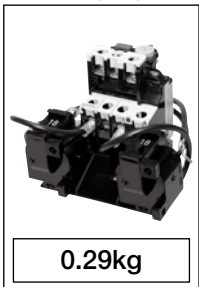

For combination with the following magnetic contactors
 TH-T18SR: S-T10, T12, T20 SD-T12, T20
 TH-T18HZSR can be used independently when used in combination with the independent mounting unit UT-HZ18.

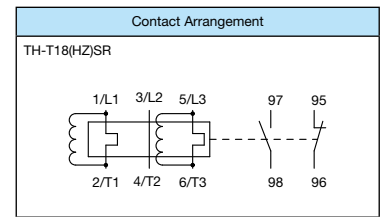

Model Name		Model Name	
TH-T18SR	0.12A to 11A 15 A	TH-T18SR	0.12A to 11A 15 A

■ T25 (The diagrams show models without "BC".)

TH-T25(BC)(KP)

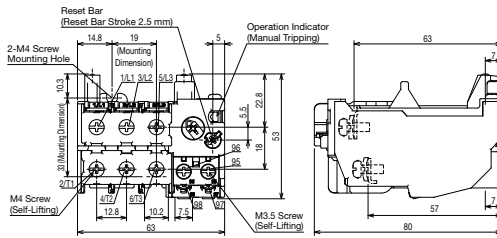
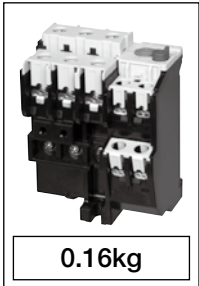

When combining with a magnetic contactor, the following connecting conductor kits (sold separately) are used
 Combination with S-T21/T25(BC), SD-T21(BC), SL(D)-T21(BC); UN-TH21
 Combination with S-T35/T50(BC), SD-T35/T50(BC), SL(D)-T35/T50(BC); UT-TH50
 Independent DIN rail mounting is possible by combining with the independent mounting unit UN-RM20

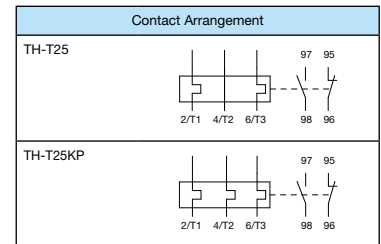

Model Name		Model Name	
TH-T25	0.24A to 15A 22 A	TH-T25BC	0.24A to 15A 22 A

TH-T25(BC)(KP)SR

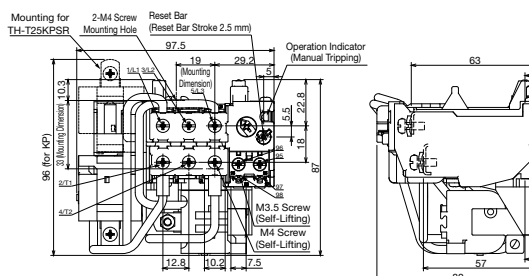
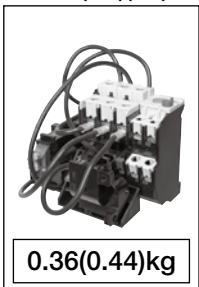

When combining with a magnetic contactor, the following connecting conductor kits (sold separately) are used
 Combination with S-T21/T25(BC), SD-T21(BC), SL(D)-T21(BC); UN-TH21
 Combination with S-T35/T50(BC), SD-T35/T50(BC), SL(D)-T35/T50(BC); UT-TH50
 * Reversible magnetic contactor with wiring streamlining terminal S-2X/T1/T25BC and TH-T25BC(KP)SR cannot be combined.

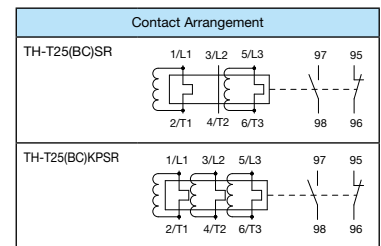

Model Name		Model Name	
TH-T25BCSR	0.24A to 15A 22 A	TH-T25SR	0.24A to 15A 22 A

■ T50 (The diagrams show models without "BC".)

TH-T50(BC)(KP)

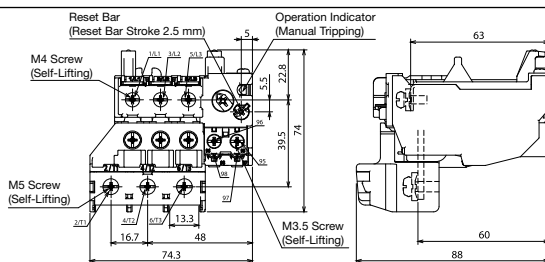
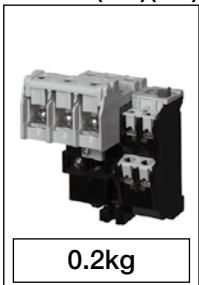

Cannot be used in independent mounting
 When combining with a magnetic contactor, the following connecting conductor kit (sold separately) is used
 Combination with S-T35/T50(BC) and SD-T35/T50(BC); UT-TH50

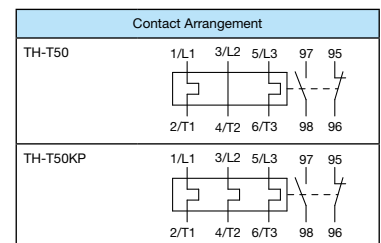

Model Name		Model Name	
TH-T50	29 A 35 A/42 A	TH-T50BC	29 A 35 A/42 A

TH-T50(BC)(KP)SR

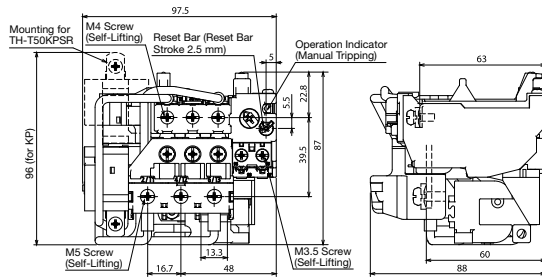
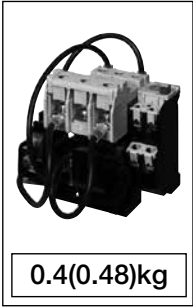

Cannot be used in independent mounting
When combining with a magnetic contactor, the following connecting conductor kit (sold separately) is used
Combination with S-T35/T50(BC) and SD-T35/T50(BC): UT-TH50

Contact Arrangement	
TH-T50(BC)SR	
TH-T50(BC)KPSR	
Model Name	
TH-T50SR	29 A 35 A/42 A

T65 (The diagrams show models without "CW".)

TH-T65(CW)(KP)

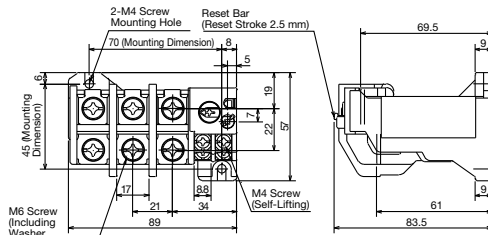

When combining with a magnetic contactor, the following connecting conductor kits (sold separately) are used
Combination with S(D)-T65/T80: BH559N350
Combination with S-T100: BH569N350
Combination with SD-T100: BH569N352

Contact Arrangement	
TH-T65	
TH-T65KP	
Model Name	
TH-T65	15A to 54A

TH-T65(KP)SR

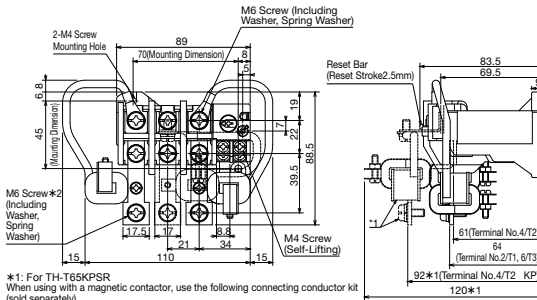

*1: For TH-T65KPSR
When using with a magnetic contactor, use the following connecting conductor kit (sold separately).
Combination with S(D)-T65/T80: BH559N350
Combination with S-T100: BH569N350
Combination with SD-T100: BH569N352

Contact Arrangement	
TH-T65SR	
TH-T65KPSR	
Model Name	
TH-T65SR	15A to 54A

T100

TH-T100(KP)

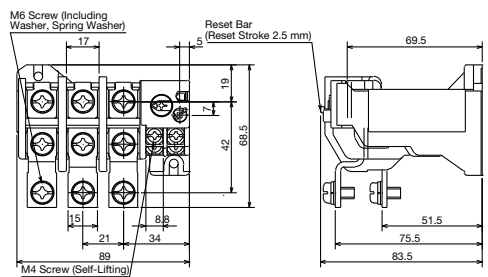

Cannot be used in independent mounting
When combining with a magnetic contactor, the following connecting conductor kits (sold separately) are used
Combination with S(D)-T80: BH559N350
Combination with S-T100: BH569N350
Combination with SD-T100: BH569N352

Contact Arrangement	
TH-T100	
TH-T100KP	
Model Name	
TH-T100	67A/82A

TH-T100(KP)SR

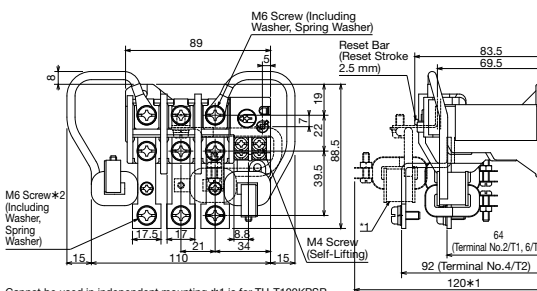

Cannot be used in independent mounting *1 is for TH-T100KPSR
When combining with a magnetic contactor, the following connecting conductor kits (sold separately) are used
Combination with S(D)-T80: BH559N350
Combination with S-T100: BH569N350
Combination with SD-T100: BH569N352

Contact Arrangement	
TH-T100SR	
TH-T100KPSR	
Model Name	
TH-T100SR	67A/82A

5.11 Operating Characteristic of Thermal Over Relay (Ambient Temperature of 20°C)

Refer to page 143 regarding the connecting electric wire size.

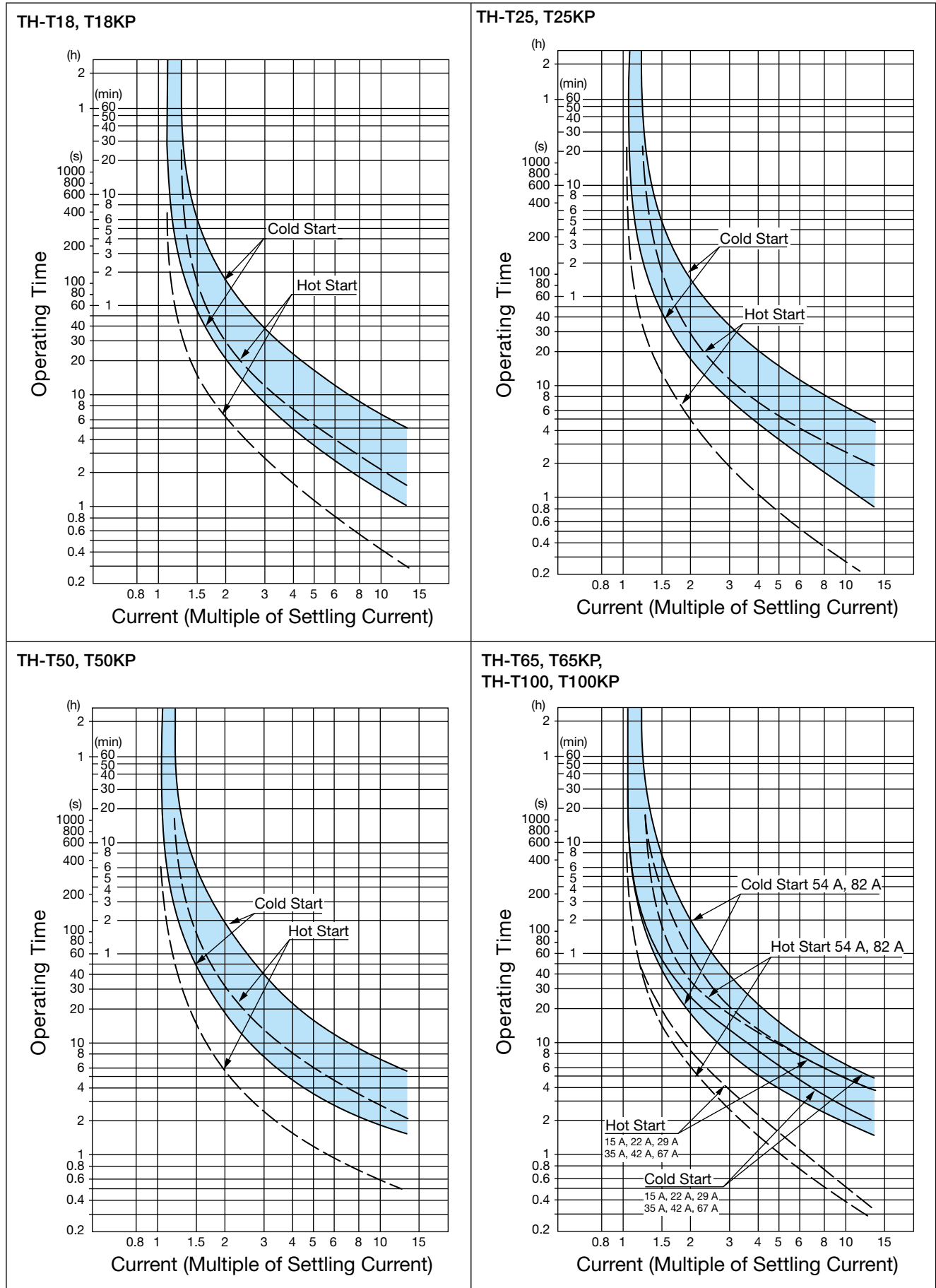

5

TH-T/N Type Thermal Overload Relays

TH-T18SR

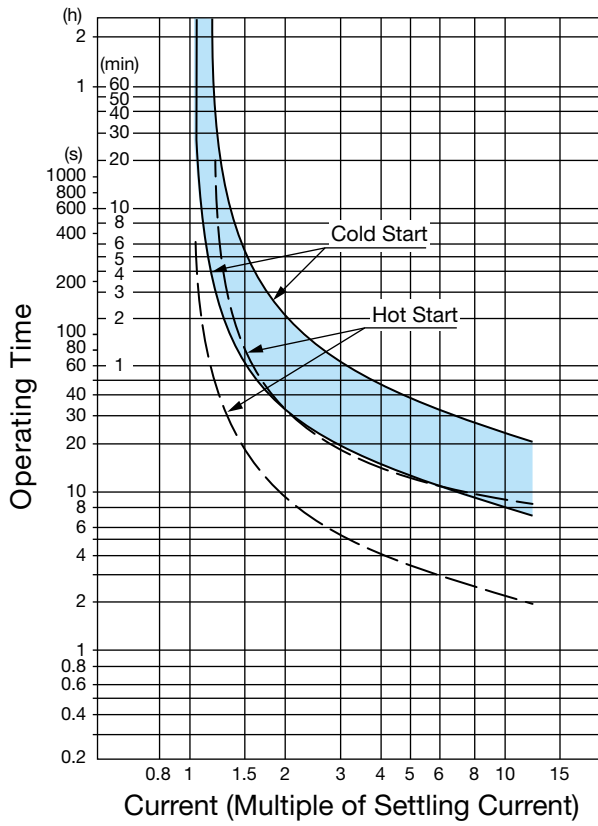

TH-T25SR, T25KPSR

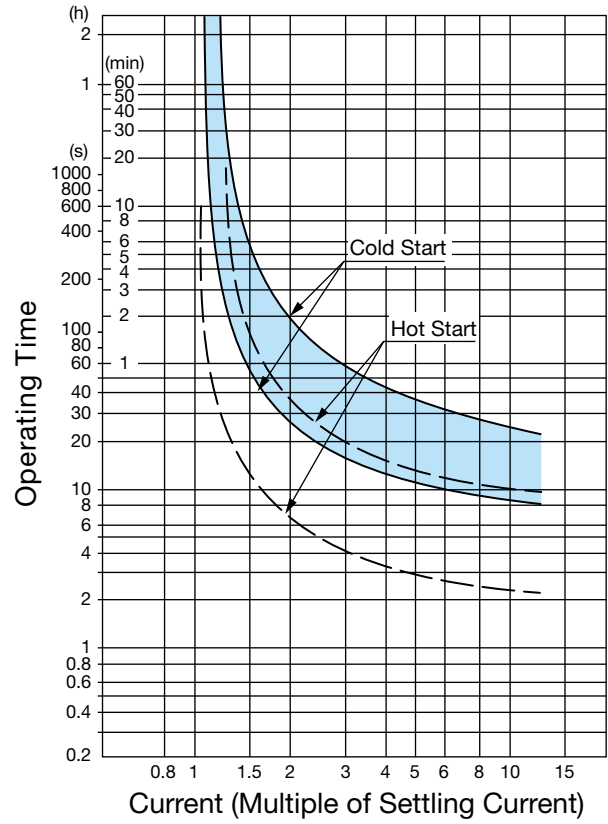

TH-T50SR, T50KPSR

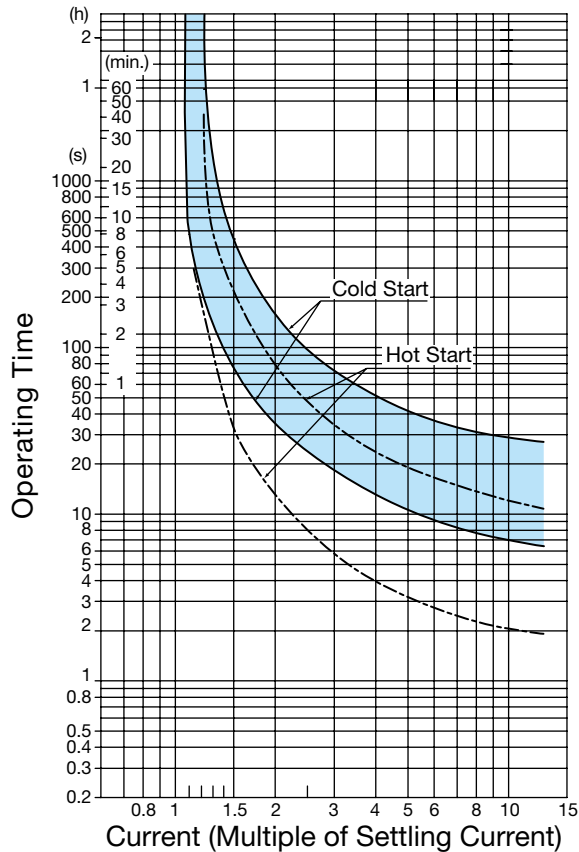

TH-T65SR, T65KPSR,
TH-T100SR, T100KPSR

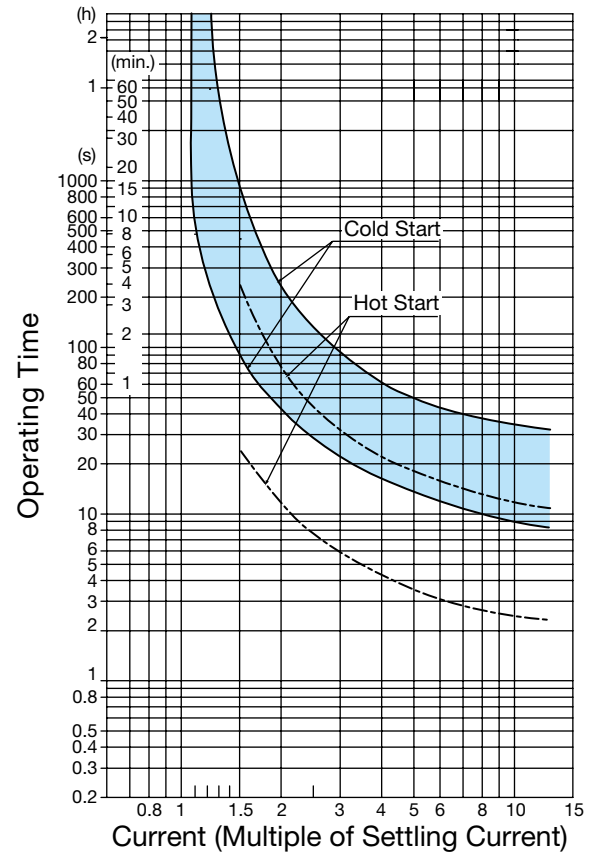

TH-T18FSKP

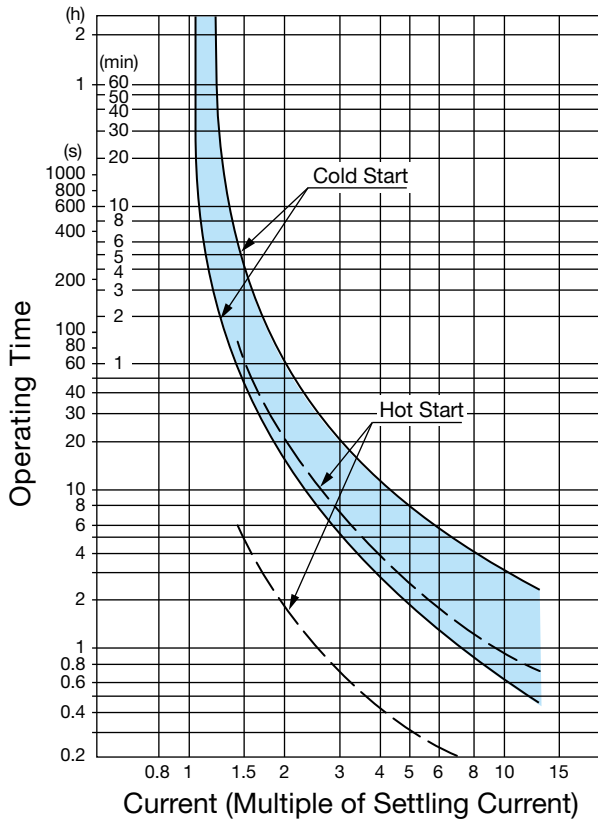

TH-T25FS, TH-T25FSKP,
TH-T50FS, TH-T50FSKP

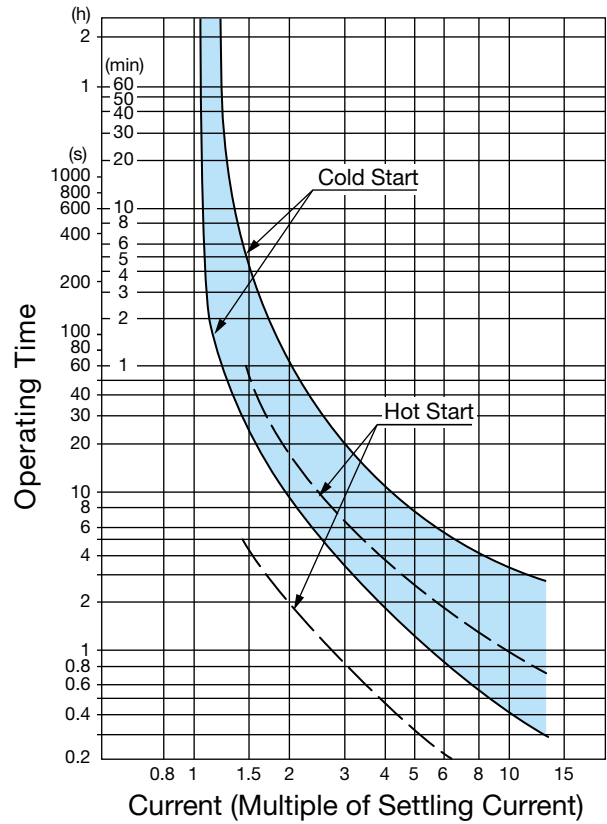

TH-T65FS, T65FSKP,
TH-T100FS, T100FSKP

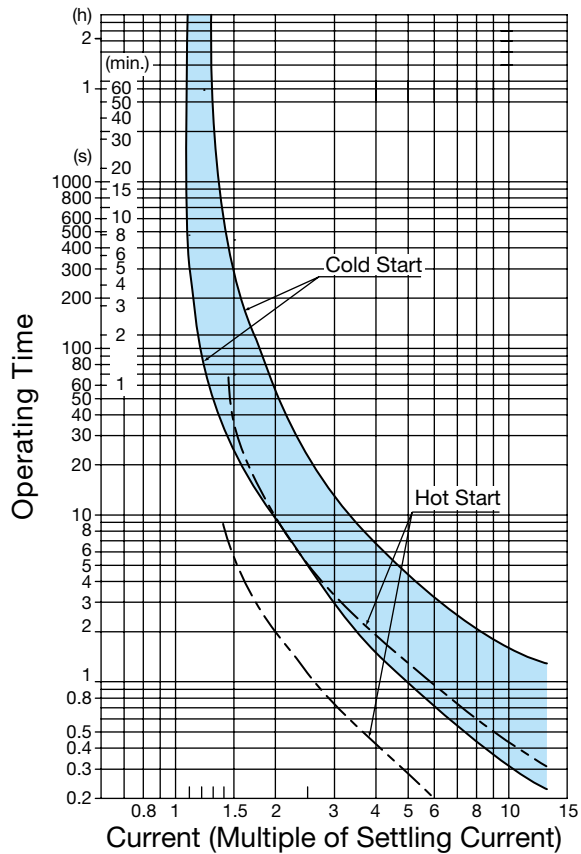

5 TH-T/N Type Thermal Overload Relays

5.12 How to Order

Follow the steps below when ordering. (Enter a space in ▲.)

● TH-T Thermal Overload Relays

Model Name TH-T25	▲	Heater Designation 15A
----------------------	---	---------------------------

Specify from the following model name codes.

Specify the heater designation from pages 145, 146 or 147. When the full-load current of the motor is included in 2 heater designations, give priority to the heaters listed in the table on page 48.

● Model Name Codes of Thermal Overload Relays

<table border="1" style="width: 100%;"> <tr><td style="text-align: center;">TH</td><td style="text-align: center;">-</td><td style="text-align: center;">T18</td></tr> </table>	TH	-	T18	<table border="1" style="width: 100%;"> <tr><td style="text-align: center;">KP</td><td style="text-align: center;">▲</td><td style="text-align: center;">Heater Designation</td></tr> </table>	KP	▲	Heater Designation															
TH	-	T18																				
KP	▲	Heater Designation																				
<table border="1" style="width: 100%;"> <tr><th style="text-align: left;">Frame</th></tr> <tr><td>T18</td></tr> <tr><td>T25</td></tr> <tr><td>T50</td></tr> <tr><td>T65</td></tr> <tr><td>T100</td></tr> </table>	Frame	T18	T25	T50	T65	T100	<table border="1" style="width: 100%;"> <tr><th style="text-align: left;">Symbol</th><th style="text-align: left;">Specifications</th></tr> <tr><td>None</td><td>With 2-Element</td></tr> <tr><td>KP</td><td>With 3-Element (2E)</td></tr> <tr><td>FS</td><td>Quick Trip Type</td></tr> <tr><td>SR</td><td>With Saturable Reactor</td></tr> <tr><td>BC</td><td>Wiring Streamlining Terminal</td></tr> <tr><td>AR</td><td>Automatic Reset</td></tr> </table>	Symbol	Specifications	None	With 2-Element	KP	With 3-Element (2E)	FS	Quick Trip Type	SR	With Saturable Reactor	BC	Wiring Streamlining Terminal	AR	Automatic Reset	
Frame																						
T18																						
T25																						
T50																						
T65																						
T100																						
Symbol	Specifications																					
None	With 2-Element																					
KP	With 3-Element (2E)																					
FS	Quick Trip Type																					
SR	With Saturable Reactor																					
BC	Wiring Streamlining Terminal																					
AR	Automatic Reset																					

● TH-N Thermal Overload Relays

Model Name TH-N120KP	▲	Heater Designation 82A
-------------------------	---	---------------------------

Specify from the following model name codes.

Specify the heater designation from pages 145, 146 or 147. When the full-load current of the motor is included in 2 heater designations, give priority to the heaters listed in the table on page 48.

● Model Name Codes of Thermal Overload Relays

<table border="1" style="width: 100%;"> <tr><td style="text-align: center;">TH</td><td style="text-align: center;">-</td><td style="text-align: center;">N220</td></tr> </table>	TH	-	N220	<table border="1" style="width: 100%;"> <tr><td style="text-align: center;">KP</td><td style="text-align: center;">▲</td><td style="text-align: center;">Heater Designation</td></tr> </table>	KP	▲	Heater Designation															
TH	-	N220																				
KP	▲	Heater Designation																				
<table border="1" style="width: 100%;"> <tr><th style="text-align: left;">Frame</th></tr> <tr><td>N120</td></tr> <tr><td>N120TA</td></tr> <tr><td>N220</td></tr> <tr><td>N400</td></tr> <tr><td>N600</td></tr> </table>	Frame	N120	N120TA	N220	N400	N600	<table border="1" style="width: 100%;"> <tr><th style="text-align: left;">Symbol</th><th style="text-align: left;">Specifications</th></tr> <tr><td>None</td><td>With 2-Element</td></tr> <tr><td>KP</td><td>With 3-Element (2E)</td></tr> <tr><td>RH</td><td>For Magnetic Starter</td></tr> <tr><td>HZ</td><td>For Independent Mounting</td></tr> <tr><td>SR</td><td>With Saturable Reactor</td></tr> <tr><td>AR</td><td>Automatic Reset</td></tr> </table>	Symbol	Specifications	None	With 2-Element	KP	With 3-Element (2E)	RH	For Magnetic Starter	HZ	For Independent Mounting	SR	With Saturable Reactor	AR	Automatic Reset	
Frame																						
N120																						
N120TA																						
N220																						
N400																						
N600																						
Symbol	Specifications																					
None	With 2-Element																					
KP	With 3-Element (2E)																					
RH	For Magnetic Starter																					
HZ	For Independent Mounting																					
SR	With Saturable Reactor																					
AR	Automatic Reset																					

Note 1. Model names that correspond to mounting methods (for magnetic starters, independent mounting and DIN rail mounting) are shown in the table below.

For Magnetic Starters	For Independent Mounting	For DIN Rail Mounting
TH-T18 *1	TH-T18 + UT-HZ18 *2	TH-T18 + UT-HZ18 *2
TH-T25	TH-T25	TH-T25 + UN-RM20 *2
TH-T50 *1	—	—
TH-T65	TH-T65	—
TH-T100 *1	—	—
TH-N120	TH-N120	—
TH-N120TA *1	TH-N120TAHZ	—
TH-N220RH *1	TH-N220HZ	—
TH-N400RH *1	TH-N400HZ	—
—	TH-N600 + CT *3	—

- *1 Cannot be independently mounted.
- *2 Order UT-HZ18 and UN-RM20 separately from the thermal overload relay body (TH-T18 and TH-T25). (Refer to page 230)
- *3 Use TH-N600 in combination with current transformer for measuring instruments (rated secondary load of 15 VA or more). (Refer to page 136)