



MITSUBISHI Low-Voltage Air Circuit Breakers type AE

MODBUS Interface unit (BIF-MD)

INSTRUCTION MANUAL

ACB types covered in this manual

AE630-SW AE1000-SW AE1250-SW AE1600-SW

AE2000-SWA

AE2000-SW AE2500-SW AE3200-SW

AE4000-SWA

AE4000-SW AE5000-SW AE6300-SW

IMPORTANT NOTE: Before using these Series AE breakers, please read these instructions carefully, and make sure that all actual users also read them.

● SAFETY PRECAUTIONS ●



Make sure to observe the following matters of safety

- Before using the device, make sure to read these safety precautions and instruction manual thoroughly. The cautionary items noted herein are of the utmost importance for the safe use of this device, and should always be strictly followed.
- Make sure that the final user receives this manual.
- This instruction manual is prepared for an electrical expert.

The following symbols have been used:

 DANGER	<p>Failure to follow these instructions may result in dangerous conditions, which in turn could lead to severe personal injury or even death.</p>
---	---

 CAUTION	<p>Failure to follow these instructions may result in dangerous conditions, which could result in moderate to slight personal injury or damage to equipment and facilities</p>
--	--

	<p>This means prohibition. Never ignore this indication.</p>
	<p>Make sure to follow these instructions without fail.</p>



 DANGER
<ul style="list-style-type: none"> ● Do not use the device on the conditions over range. Failure to do so may result in fire. ● Do not touch the terminals. There is a risk of electrical shock.

 CAUTION
<ul style="list-style-type: none"> ● A qualified electrician should install this equipment. ● Make sure to tighten the terminal screws to the torque specified in this manual. Failure to do so may result in malfunction or fire. ● Do not install in areas subject to high temperatures, high humidity, dust, corrosive gas, vibrations, shocks, etc. To do so may result in malfunction or fire. ● Install so that trash, concrete dust, iron filings or rainwater cannot get into the device interior. Failure to do so may result in malfunction or fire.

 CAUTION
<p>Mitsubishi Electric Corporation puts the maximum effort into making electric products better and more reliable, but generally electric products may incorrect-operate under the influence of a noise etc.</p> <p>In order not to cause abnormalities to a system by the influence of a noise etc., please retry 3 times or more with master software in case of error reply or no reply.</p>

■ Module serial number combination

This manual is intended to be used in combination with the serial number of the module in the table below.
 In case of combination with modules of serial numbers other than those listed below, some functions are not available.

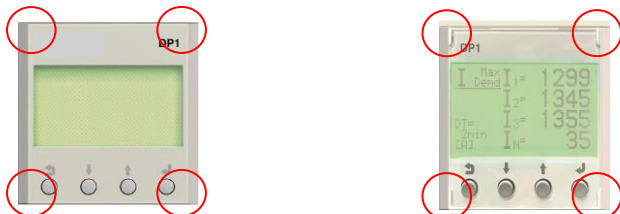
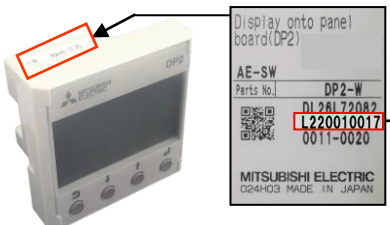
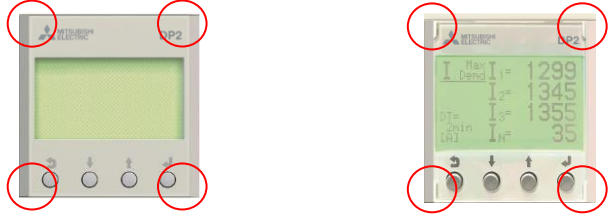
Module	Serial number	Serial number printing location
MODBUS Interface unit (BIF-MD)	G or later	 <p>G226P...</p> <p>G or later</p>
Electronic trip relay (ETR)	<p>① In case that the 5th and 6th from the left are letters: D or later</p> <p>② In case that the 5th and 6th from the left are numbers: Q or later</p>	 <p>① D229KE021 The 5th and 6th from the left D or later</p> <p>② Q22944021 The 5th and 6th from the left Q or later</p>
Display (DP1)	L or later ¹⁾	<p>■ 1): Please judge by appearance, because it is impossible to confirm the serial number. Modules with cutouts on the four corners are serial number first alphabet is a module after “L”.</p>  <p>K or earlier (Without cutouts) L or later (With cutouts)</p>
Display (DP2)	L or later ²⁾	 <p>Display onto panel board (DP2)</p> <p>AE-SW DP2-W Parts No. DL2AL720A2 L220010017 0011-0020</p> <p>MITSUBISHI ELECTRIC Q24H03 MADE IN JAPAN</p> <p>L or later</p> <p>■ 2): Distinguishable by appearance. Modules with cutouts on the four corners are serial number first alphabet is a module after “L”.</p>  <p>K or earlier (Without cutouts) L or later (With cutouts)</p>

■ EMC Directive

In IEC60947-2, following EMC tests are required.

- 1) Radiated radio frequency emission
- 2) Radiated radio frequency electromagnetic field immunity

BIF-MD shall be installed in the panel board. It effects not only for safe against electric shock but also to interrupt noise emission from the device. BIF-MD is confirmed to IEC60947-2 in accordance with following conditions.

● Installation

Install the device in power distribution board or control panel board that is made of conductive materials.

Power distribution board and control panel board have to be grounded to the earth with a thick wire of low impedance.

The frame ground terminal (FG) in the device has to be grounded to the earth with a thick wire of low impedance. (*grounded resistance: 100 ohm or less).

● Cables

MODBUS cable, Internal Transmission cable and BIF-CON cable shall be kept distance more than 100mm from the power distribution circuit.

However, when parallel installation with the power distribution circuit is required, it is necessary to increase to 300mm.

■ Dielectric voltage test

The dielectric voltage test should be executed according to the table below. Do not test in points other than a following table because unit is damaged.

Measuring point	Condition
Between main circuit and BIF-MD terminals (P1, P2)	2500VAC 1min.
Between main circuit and BIF-MD terminal (FG, Ter, T/R+, T/R-, COM, SLD)	
Between BIF-MD terminals (P1, P2) and BIF-MD terminal (FG, Ter, T/R+, T/R-, COM, SLD)	1500VAC 1min.
Between main circuit and BIF-CON terminals (C1, C2, A1, A2, U1 and U2)	2500VAC 1min.
Between BIF-MD terminals (P1 and P2) and BIF-CON terminals (C1, C2, A1, A2, U1 and U2)	1500VAC 1min.
Between BIF-MD terminals (FG, Ter, T/R+, T/R-, COM, SLD) and BIF-CON terminals (C1, C2, A1, A2, U1 and U2)	
BIF-CON terminals (C1 and C2), BIF-CON terminals (A1 and A2), BIF-CON terminals (U1 and U2), each other	

■ Guarantee

The period of guarantee is for 1 year from the sale date except in case of the failure has been caused by bad handling of the device.

- Table of Contents -

1. System Overview	6
2. Specifications	
2.1 BIF-MD	7
2.2 BIF-CON	10
3. Part Names and Settings	
3.1 BIF-MD	11
3.2 BIF-CON	15
4. Installation	
4.1 IEC rail installation	19
4.2 Bracket installation	20
5. MODBUS Data Format	
5.1 Standard frame	21
5.2 Bit sequence	21
5.3 MODBUS Message RTU Framing	21
5.4 Framing of Query and Response	22
5.5 MODBUS Exception Response	23
5.6 Resister address	24
6. Outline dimensions	37

1. System Overview

BIF-MD (MODBUS Interface unit) is used for monitoring and operating ACB with MODBUS RTU protocol.
 *MODBUS is a trademark of Schneider Electric USA Inc.

●Monitoring:

- Measurement items (current, voltage, power, harmonics, energy, etc)
- Trip and alarm information (present status, history)
- Breaker status (Breaker ON/OFF status, Position of Breaker (*BIF-CON and BIF-CL is required)).

●Operating:

- Breaker control (ON/OFF/Spring charge). (*CC/SHT/MD and BIF-CON is required.)
- Reset (Trip indicator, Maximum and Minimum measurement, history information).

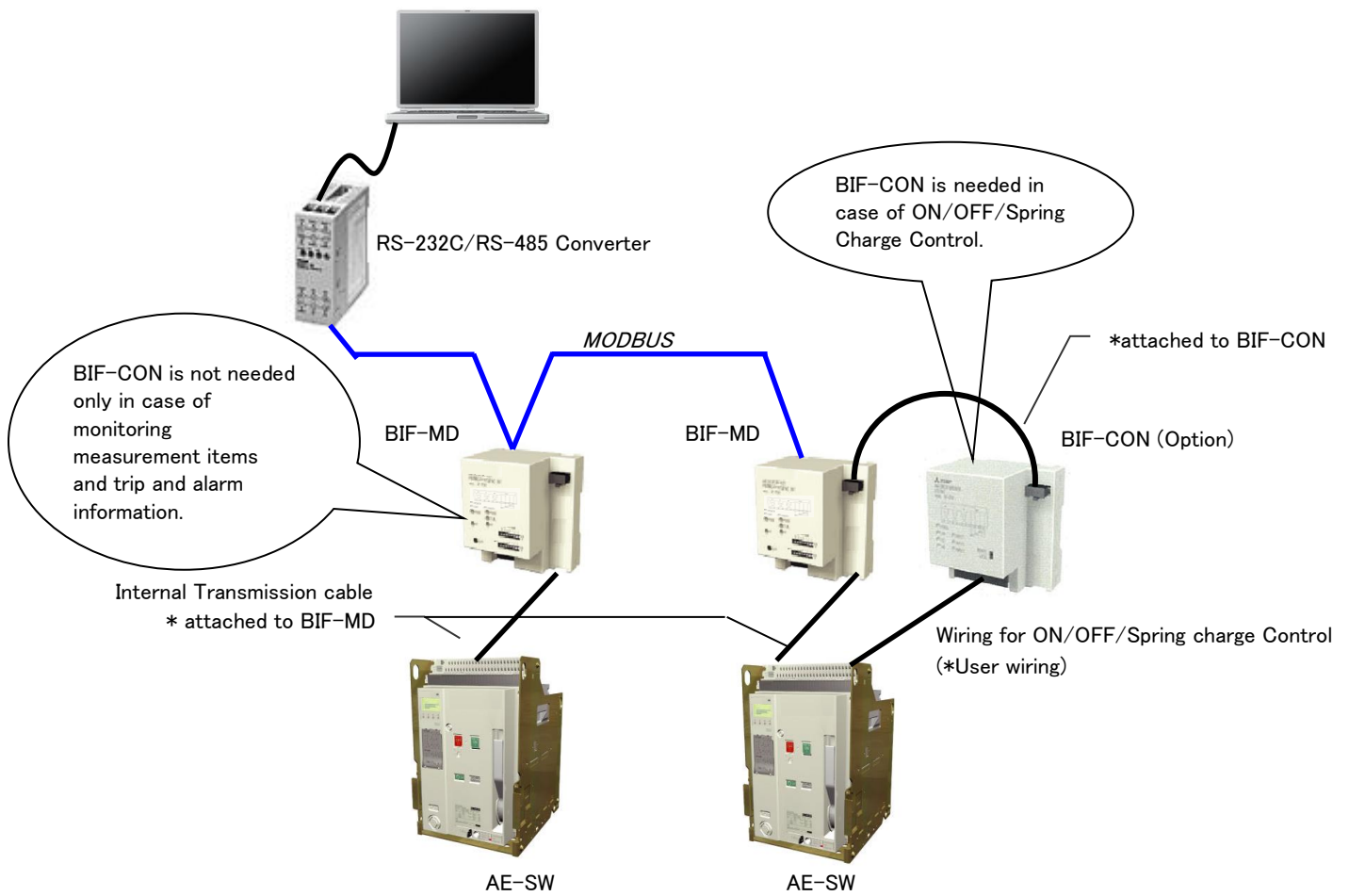

Fig 1.1 System Overview

2. Specifications

2.1 BIF-MD

The general specification of BIF-MD is shown in table 2.1.

Table 2.1 General specification of BIF-MD

Item	Specifications
Type name	BIF-MD
Power supply	100-240V AC•DC (50/60Hz)
Power consumption	3VA (not including BIF-CON) 5VA (including BIF-CON)
External dimensions	90(width) x 100(height) x 65(depth)
Operating ambient temperature	-5 to +40°C (However, the average of temperature per 24hours must not exceed +35°C)
Storage ambient temperature	-20 to +60°C (However, the average of temperature per 24hours must not exceed +35°C)
Operating/Storage ambient humidity	Max. 85%RH (no condensation) at the max. +40°C in the clean air conditions.
Operating/Storage ambience	Do not use and store in atmospheres with sulfide gas, ammonia gas, etc. (H ₂ S 0.01ppm or less, SO ₂ 0.05ppm or less, NH ₃ 0.25ppm or less)
Operating altitude	Max. 2000m (6600ft.)
Installation	35mm IEC rail/Bracket

The functional specifications of BIF-MD are shown in table 2.2.

Table 2.2 MODBUS specification of BIF-MD

Item	Specifications
Physical interface	RS-485
Protocol	MODBUS RTU mode
Transmission Wiring Type	Multi-point bus (either directly on the trunk cable or forming a daisy-chain)
Baud Rate	2400, 4800, 9600, 19200, 38400 bps (selectable)
Data bit	8
Stop bit	1,2 (selectable)
Parity	Odd, Even, Non (selectable)
Maximum number of unit (without repeater)	31
Range of setting bus address	1 to 127
Response time	500ms or less
Recommended cable	Shielded twisted pair, AWG 24 or wider gauge.
Distance	1000m
Terminate	120 Ω (1/2W) (There is a terminate register in BIF-MD. In case of the ends of network, connect two Ter. terminals by short wire.)

The setting items specifications of BIF-MD are shown in table 2.3.
Refer to Section 5.6 for details.

Table2.3 Setting items specification of BIF-MD

Item		Setting parameter/range	Setting for shipment
Date & Time	Date	Year:00(2000) to 99(2099), Month :01 to 12, Day:01 to 31	JAN/01/2004
	Time	Hour:00 to 23, Minute:00 to 59, Second:00 to 59	00:00:00
Demand Time	Load Current (I)	0s to 50s (step: 10s)/	2min
	Leakage Current (I _g) ²⁾	1min to 15min (step: 1min)/	2min
	Power (P) ¹⁾	20min/30min	2min
Alarm Hold		Auto Reset/Self-Holding	Auto Reset
earth leakage pre-alarm (EPAL) ²⁾	I _{ep}	0 ³⁾ /500mA/600mA/700mA/.../I Δ n ⁴⁾ (step: 100mA)	0 (=OFF)
	T _{ep}	100ms/200ms/.../3000ms (step: 100ms)	3000ms
Operating voltage (V _n) ^{1) 5) 6)}		3 ϕ 4W: 100V to 300V (step 1V) 3 ϕ 3W: 173V to 520V (step 1V)	3 ϕ 4W: 240V 3 ϕ 3W: 240V
Characteristic bit data (Voltage protection) ^{1) 5) 6)}		Refer to table 5.6.17	Alarm
Under Voltage (UV) ^{1) 5) 6)}	Pick-up voltage(V _{UV})	0% ⁷⁾ /70% to 95% (step: 1%)	0%(OFF)
	Time (T _{UV})	2s to 10s (step: 1s)	2s
Over Voltage (OV) ^{1) 5) 6)}	Voltage (V _{OV})	0% ⁸⁾ /105% to 130% (step: 1%)	0%(OFF)
	Time (T _{OV})	2s to 10s (step: 1s)	2s
Voltage Unbalance (UB) ^{1) 5) 6)}	Voltage (V _{UB})	0% ⁹⁾ /5% to 30% (step: 1%)	0%(OFF)
	Time (T _{UB})	2s to 10s (step: 1s)	2s

■1): This cannot be used when EX1 and VT unit (VT) are not equipped.

■2): These can be available only when the Optional setting module type is E1 (Earth leakage protection).

■3): In case of I_{ep} =0mA, pre-alarm earth leakage function is disabled(OFF).

■4): I_{ep} must be set to I Δ n or less.

■5): In case of module other than the specified serial number is connected, these functions are not available.

■6): In case of Electric trip relay (for protective coordination use : WF) is connected, these functions are not available.

■7): In case of V_{UV} =0%, Under Voltage protective function is disabled(OFF).

■8): In case of V_{OV} =0%, Over Voltage protective function is disabled(OFF).

■9): In case of V_{UB} =0%, Voltage Unbalance protective function is disabled(OFF).

The measurement specifications of BIF-MD are shown in table 2.4.
Refer to Section 5.6 for details.

Table2.4 measurement items specification of BIF-MD

Item		Measurement Range	Unit	Accuracy		Cut off	
				EX1	EX2	EX1	EX2
Load current		0 to $2 \times I_n$ [A]	$I_n < 500A$: [0.1A] $I_n \geq 500A$: [A]	$\pm 2.5\%$ ⁶⁾	$\pm 5.0\%$ ⁶⁾	2.0% ⁶⁾	5.0% ⁶⁾
Earth Leakage current ^{2) 5)}		0 to $2 \times I_{\Delta n_max}$ [A]	[0.1A]	$\pm 15\%$ ^{3) 6)}	$\pm 15\%$ ^{3) 6)}	3.0% ⁶⁾	3.0% ⁶⁾
Voltage ^{1) 5)}	Line	0 to 725[V]	[V]	$\pm 2.5\%$ ⁶⁾	-	10V	-
	Phase	0 to 420[V]					
Power ^{1) 5)}	Active	$-\sqrt{3} \times (2 \times I_n [A]) \times 725$ [V] to $+\sqrt{3} \times (2 \times I_n [A]) \times 725$ [V]	$I_n < 1000A$: [0.1kW] $I_n \geq 1000A$: [kW]	$\pm 2.5\%$ ⁶⁾	-	2.0% ⁶⁾	-
	Reactive	$-\sqrt{3} \times (2 \times I_n [A]) \times 725$ [V] to $+\sqrt{3} \times (2 \times I_n [A]) \times 725$ [V]	$I_n < 1000A$: [0.1kvar] $I_n \geq 1000A$: [kvar]	$\pm 2.5\%$ ⁶⁾	-	2.0% ⁶⁾	-
	Apparent ⁴⁾	0 to $+\sqrt{3} \times (2 \times I_n [A]) \times 725$ [V]	$I_n < 1000A$: [0.1kVA] $I_n \geq 1000A$: [kVA]	$\pm 2.5\%$ ⁶⁾	-	2.0% ⁶⁾	-
Power factor ^{1) 5) 8)}		-50 [%] to 100 [%] to +50 [%]	[0.1%]	$\pm 5.0\%$ ⁶⁾	-	-	-
Energy ¹⁾	Active	0 to 99999999 [kWh]	[kWh]	$\pm 2.5\%$ ⁷⁾	-	0.4% ⁶⁾	-
	Reactive	0 to 99999999 [kvarh]	[kvarh]	$\pm 2.5\%$ ⁷⁾	-	0.4% ⁶⁾	-
Harmonics current ¹⁾ (Max 19th)	RMS	0 to $2 \times I_n$ [A]	$I_n < 500A$: [0.1A] $I_n \geq 500A$: [A]	$\pm 2.5\%$ ⁶⁾	-	2.0% ⁶⁾	-
	Distortion	0 to 200 [%]	[0.1%]				
Frequency ¹⁾		45 to 65 [Hz]	[Hz]	$\pm 2.5\%$ ⁷⁾	-	-	-
Fault current /voltage	LTD/STD/INST	0 to $20 \times I_n$ [A]	[10A]	$\pm 20\%$ ⁷⁾	$\pm 20\%$	-	-
	GFR	0 to $2 \times I_n$ [A]	[A]				
	ER	0 to $2 \times I_{\Delta n_max}$ [A]	[0.1A]				
	UV ^{1) 9) 10)}	0 to 725 [V]	[V]				
	OV ^{1) 9) 10)}	0 to 725 [V]	[V]				
	UB ^{1) 9) 10)}	0 to 30 [%]	[%]	$\pm 2.5\%$ ⁶⁾	-	-	-
ON/OFF Counter		0 to 65535	-	-	-	-	-
Main body temperature ^{9) 10) 11)}		20 to 150 [°C]	[°C]	$\pm 10^\circ\text{C}$	$\pm 10^\circ\text{C}$	-	-

■1): These items cannot be metered when EX1 and VT unit (VT) are not equipped.

■2): The leakage current metering is available only when the Optional setting module type is E1 (Earth leakage protection).

■3): Include the accuracy of ZCT.

■4): When using at 3 ϕ 3W system, the apparent power is calculated by $(\sqrt{3}/2) \times (I1 \times V12 + I3 \times V23)$.

Therefore, the accuracy may not be ensured in the unbalanced circuit.

■5): Rated voltage of measurement is 440V. Rated power and energy of measurement is $\sqrt{3} \times I_n \times 440V$.

Rated earth leakage current of measurement is $I_{\Delta n_max}$ (=10A). Rated power factor is 90 degrees.

■6): Accuracy and cut off are defined as percentage of rated value.

■7): Accuracy is defined as percentage of true value.

■8): Power factor is measured for only fundamental wave. A waveform distortion is not included for power factor calculation.

■9): In case of module other than the specified serial number is connected, these functions are not available.

■10): In case of Electric trip relay (for protective coordination use : WF) is connected, these functions are not available.

■11): TAL sensor is needed.

2.2 BIF-CON (Option)

The general specifications of BIF-CON are shown in table 2.5.

Table 2.5 General specifications of BIF-CON

Item		Specifications
Type name		BIF-CON
Power supply		Supplied from BIF-MD
Digital input	Number of channel	3 channels (INPUT1, INPUT2, INPUT3, general use)
	Isolation	Photo coupler isolation
	Signal level	12VDC, 30mA
Digital output	Number of channel	3 channels (*SHT ¹⁾ /CC/MD exclusive use)
	Isolation	Relay isolation
	Contact capacity	8A at 250V AC·DC (resistive load) ¹⁾
External dimensions		90(width) x 100(height) x 65(depth)
Operating ambient temperature		-5 to +40°C (However, the average of temperature per 24hours must not exceed +35°C)
Storage ambient temperature		-20 to +60°C (However, the average of temperature per 24hours must not exceed +35°C)
Operating/Storage ambient humidity		max. 85%RH (no condensation) at the max. +40°C in the clean air conditions.
Operating/Storage ambience		Do not use and store in atmospheres with sulfide gas, ammonia gas, etc. (H ₂ S 0.01ppm or less, SO ₂ 0.05ppm or less, NH ₃ 0.25ppm or less)
Operating altitude		max. 2000m (6600ft.)
Installation		35mm IEC rail/Bracket

■1): SHT (AC380-500V) cannot be used.

3. Part Names and Settings

3.1 BIF-MD

The unit overview is shown as below.

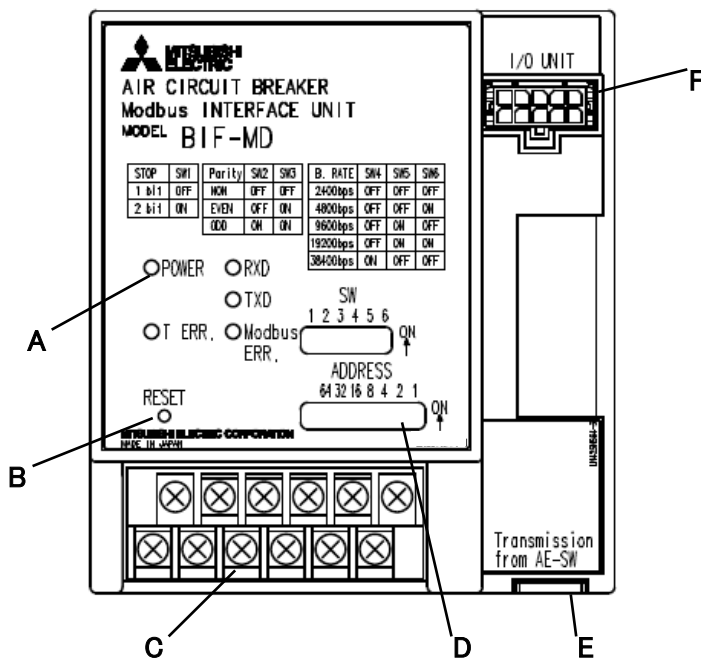

Fig 3.1: Front view

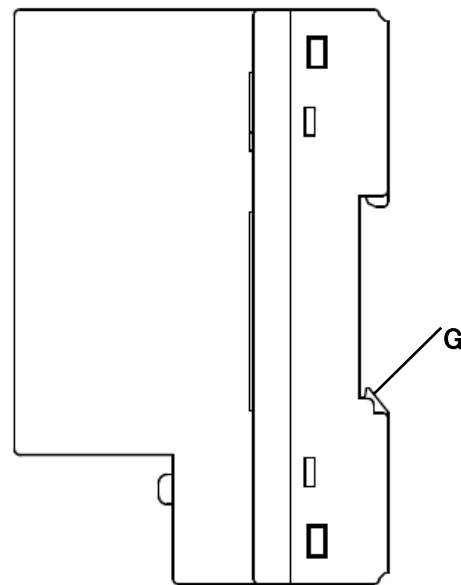

Fig 3.2: Side view

●(A) LEDs

Name	Indication	Description	Check
POWER	ON	Power is supplied.	
	OFF	Power is not supplied.	
T ERR.	Flashing	Internal transmission fault	Connection of internal transmission cable. Power supply of Power supply module (P1-P5).
	OFF	Normal operating state	
RXD	Flashing	Frame reception.	
	OFF	No reception.	
TXD	Flashing	Frame sending.	
	OFF	No sending.	
Modbus ERR.	Flashing	Transmission fault	Setting of Stop bit, Parity, Baud Rate. Connection of internal transmission cable. Connection of MODBUS cable. Terminator. Programming (Function code, address, setting data.)
	ON	Setting switch fault	Setting of Stop bit, Parity, Baud Rate, Bus address.
	OFF	No fault	

●(B) RESET Switch

RESET Switch is used to reset the BIF-MD without power off.
After changing the switch while power supply is on, push this switch.

●(C) Terminals

Name ¹⁾	Description	Screw ²⁾ (Tighten torque)	Notes
P1, P2	100–240V AC·DC	M3 (0.55±0.05N·m)	Fuse or Circuit Breaker shall be installed in power supply line. Do not connect to main circuit of breaker directly.
FG	Frame ground		1. This terminal has to be grounded to the protective ground conductor by a thick wire of low impedance (*ground resistance: 100 ohm or less). 2. Connect the FG terminal of each BIF-MD independently. If not use ground independently, use common ground according to the figure 3.3.
T/R+	RS-485 signal +		For MODBUS cable.
T/R-	RS-485 signal -		
COM	RS-485 signal GND		In case of two wires cable, no need to use.
SLD	MODBUS cable shield		
Ter.	Terminator		There is a terminate register in this device. In case of the ends of network, connect two Ter. terminals by short wire as shown in figure 3.4.

■ 1): Terminal assignment is shown in "6. Outline dimensions".

■ 2): These terminals should be connected with wire using crimp-type terminal.
The available crimp-type terminal is shown in figure 3.5.

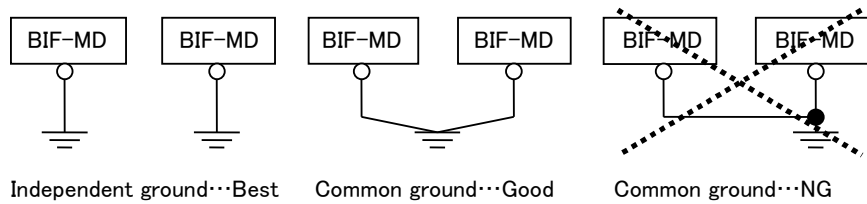

Fig 3.3: Ground connection

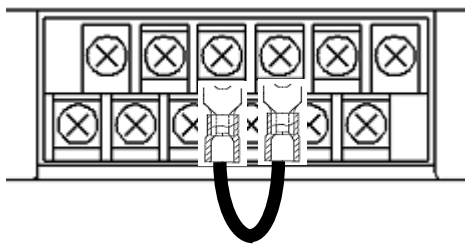
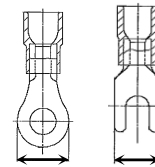

Fig 3.4: Short wire in case of ends of network



max. 6mm

Fig 3.5: Crimp-type terminal

●(D) SWITCH

The setting of switches is effective when power supply is turned ON.

After changing the switch while power supply is on, push RESET switch (see also “(B) RESET switch”).

<BUS ADDRESS>

The BIF-MD supports the address range from 1 through 127.

The address is set in binary form shown as below sample.

Sample setting:

ON : 32, 8, 1

OFF: 64, 16, 4, 2

ADDRESS: $32 + 8 + 1 = 41$

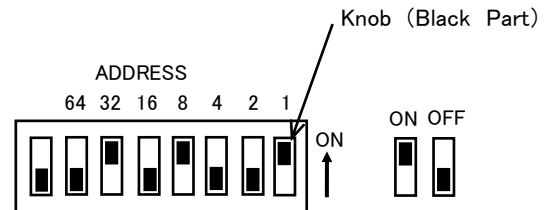

<Stop bit, Parity, Baud RATE>

Setting of stop bit, parity, Baud Rate must correspond with master setting.

STOP bit	SW 1
1 bit	OFF
2 bit	ON

Parity	SW 2	SW 3
NON	OFF	OFF
EVEN	OFF	ON
ODD	ON	ON

B. RATE	SW 4	SW 5	SW 6
2400bps	OFF	OFF	OFF
4800bps	OFF	OFF	ON
9600bps	OFF	ON	OFF
19200bps	OFF	ON	ON
38400bps	ON	OFF	OFF



Do not change the setting of switches with mechanical pencil. It may cause malfunction by carbon dust.

Sample setting:

Stop bit : 1 bit

Parity: EVEN

B. RATE: 38400bps

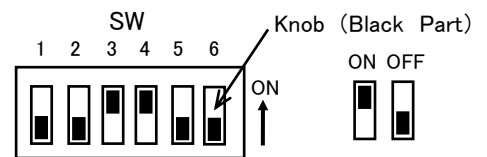

●(E) Connector for AE-SW internal transmission cable

This connector is used for internal transmission with AE-SW.

Wiring connection is shown as below.

■Note: Only one BIF-MD can be connected to AE-SW.

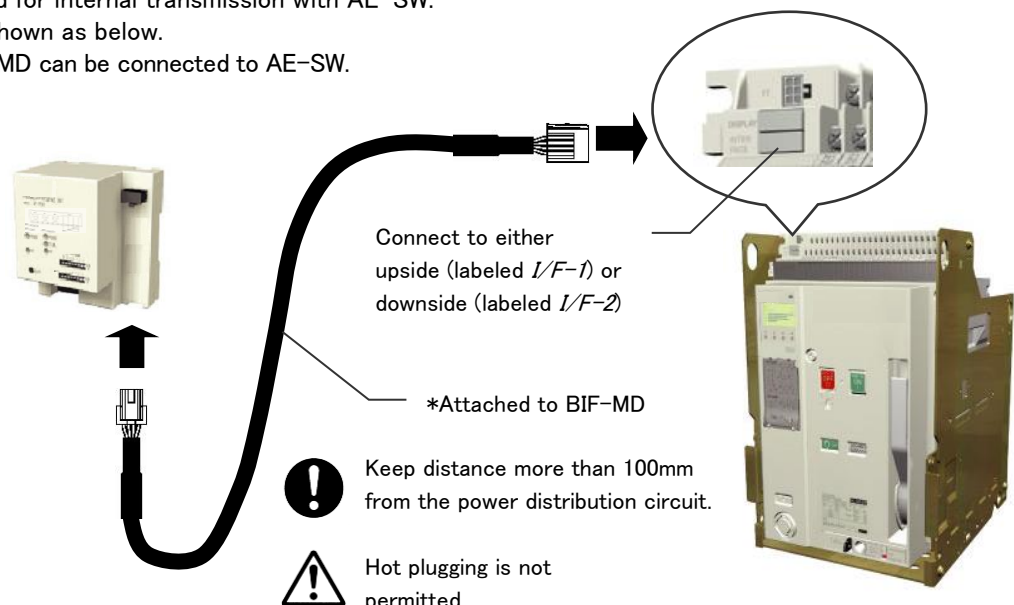

Fig 3.6: Wiring Connection

●(F) Connector for I/O unit (BIF-CON) connection

This connector is used for connection to I/O unit (BIF-CON).
Wiring connection is shown as below.

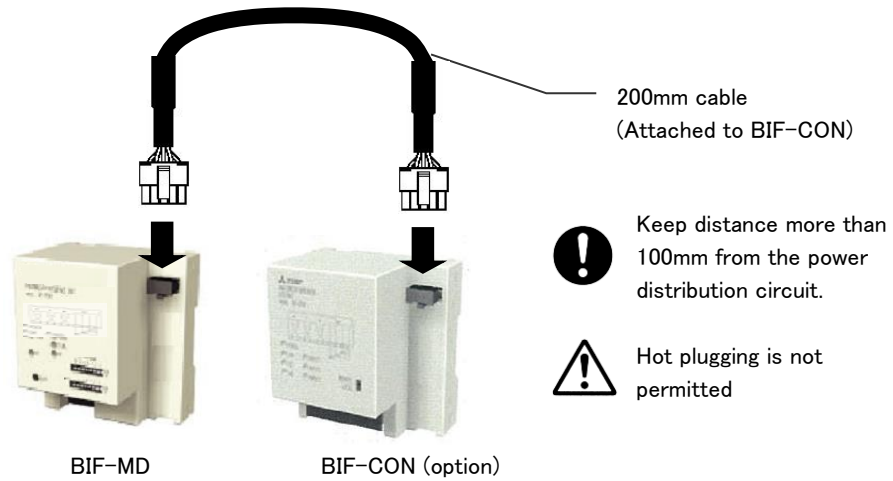

Fig 3.7: Wiring Connection

●(G) IEC rail latch

This is used to attach the BIF-MD to a IEC mounting rail.
IEC rail installation is shown in "4.1 IEC rail installation".

3.2 BIF-CON

The unit overview is shown as below.

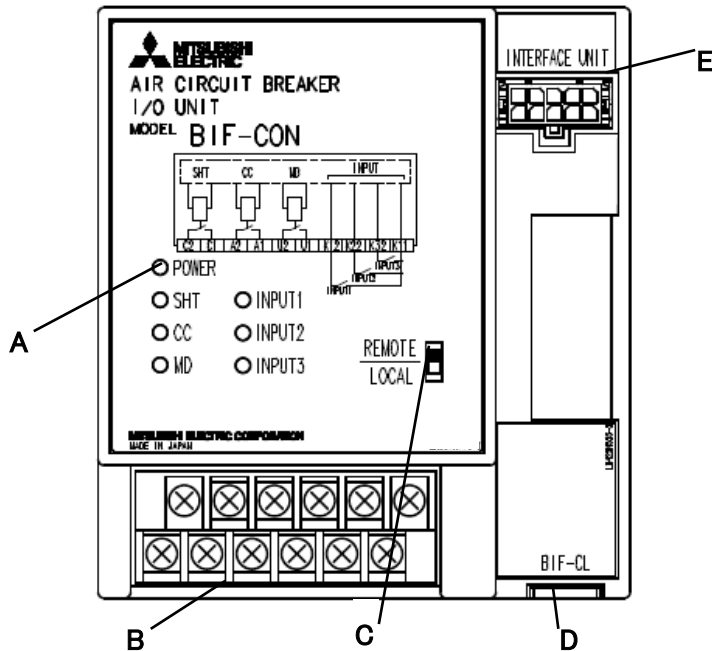

Fig 3.8: Front view

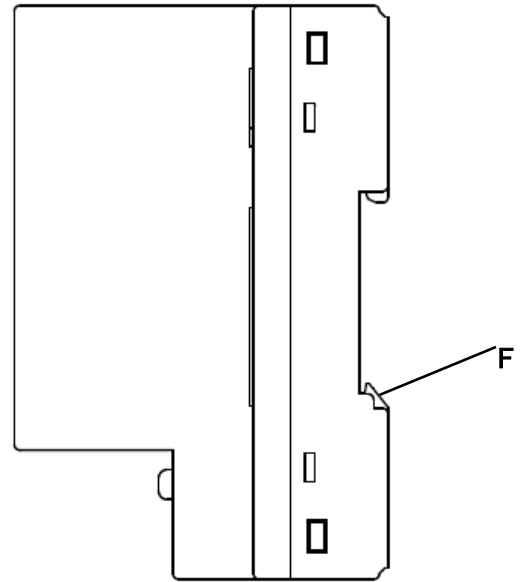

Fig 3.9: Side view

●(A) LEDs

Name	Indication	Description
POWER	ON	Power is supplied from BIF-MD correctly
	OFF	Power is not supplied
SHT	ON	1a contact for SHT ¹⁾ is closed (500ms)
	OFF	1a contact for SHT ¹⁾ is open
CC	ON	1a contact for CC ²⁾ is closed (500ms)
	OFF	1a contact for CC ²⁾ is open
MD	ON	1a contact for MD ³⁾ is closed (5s)
	OFF	1a contact for MD ³⁾ is open
INPUT1	ON	INPUT1 signal is ON
	OFF	No INPUT1 signal
INPUT2	ON	INPUT2 signal is ON
	OFF	No INPUT2 signal
INPUT3	ON	INPUT3 signal is ON
	OFF	No INPUT3 signal

■ 1): SHT is a type name of *AE-SW Shunt trip device* which open the main contact via remote control.

For details about SHT, please see "*AE-SW INSTRUCTION MANUAL*".

■ 2): CC is a type name of *AE-SW Closing coil* which close the main contact via remote control.

For details about CC, please see "*AE-SW INSTRUCTION MANUAL*".

■ 3): MD is a type name of *AE-SW Motor charging device* which charges the closing spring for motor operating.

For details about MD, please see "*AE-SW INSTRUCTION MANUAL*".

●(B) Terminals

Name ¹⁾	Description	Screw ²⁾ (Tighten torque)
C1, C2 ³⁾	Output terminals for SHT	M3 (0.55±0.05N·m)
A1, A2 ³⁾	Output terminals for CC	
U1, U2 ³⁾	Output terminals for MD	
K12	Digital input1 terminal	
K22	Digital input2 terminal	
K32	Digital input3 terminal	
K11	Input common	

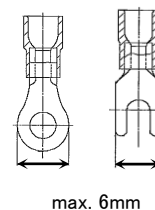
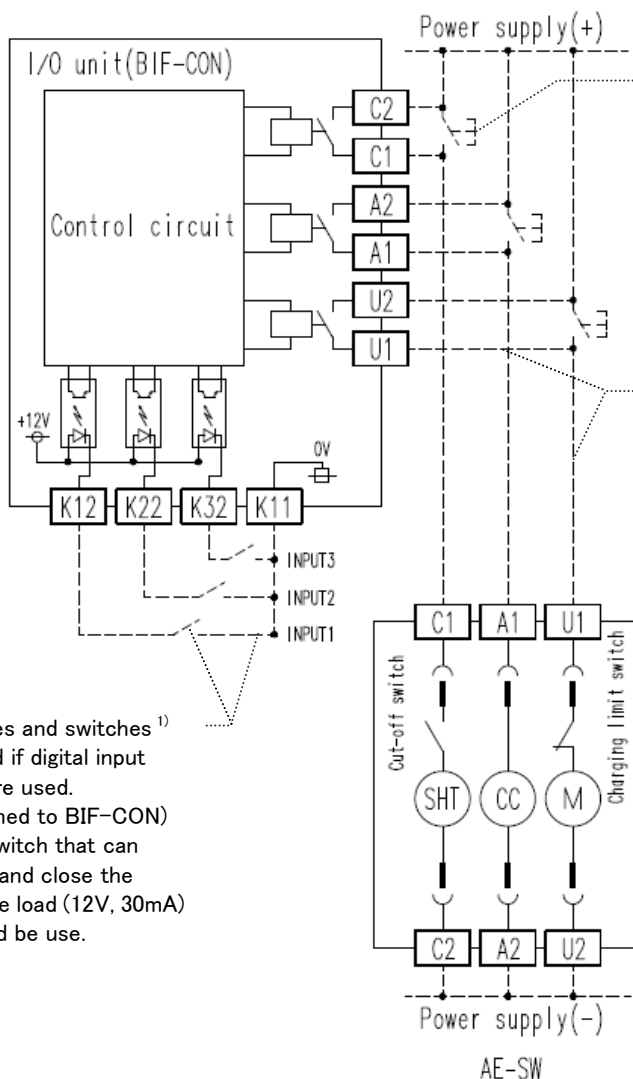

Fig 3.10: Crimp-type terminal

- 1): Terminal assignment is shown in "6. Outline dimensions".
- 2): These terminals should be connected with wire using crimp-type terminal.
The available crimp-type terminal is shown in figure 3.10.
- 3): These output terminals are exclusive to SHT/CC/MD.
- 4): About the remote control via the MODBUS network, or local control with pushbuttons, the sample of user's wiring with BIF-CON and AE-SW is shown in figure 3.11.



Pushbuttons ¹⁾ are required only if SHT/CC/MD are driven by local operation ²⁾.

- 1): Pushbuttons are not attached to BIF-CON.
Therefore, these should be prepared by the user.
- 2): In case of local operation by pushbuttons, REMOTE/LOCAL switch placed on the BIF-CON should be in LOCAL position for safety.
(see also "(C) REMOTE/LOCAL switch").

These connection cables ¹⁾ are required if SHT/CC/MD are driven by remote control ²⁾.

- 1): These cables are not attached to BIF-CON.
Therefore, these should be prepared by the user.
- 2): In case of remote control, REMOTE/LOCAL switch placed on the BIF-CON should be in REMOTE position. (see also "(C) REMOTE/LOCAL switch").

These cables and switches ¹⁾ are required if digital input functions are used.

(*not attached to BIF-CON)

- 1): The switch that can open and close the minute load (12V, 30mA) should be use.

SHT and CC cannot be driven simultaneously.

Description

	Shunt tripping device
	Closing coil
	Motor(Motor charging device)
	User's wiring
	Control circuit connector (drawout type)

Fig 3.11: Sample of user's wiring

●(C) REMOTE/LOCAL switch

The REMOTE/LOCAL switch is used for change over of remote/local control of AE-SW.

When this switch is in REMOTE position, the remote control (ACB ON/OFF and charging the spring) are available via MODBUS network.

When this switch is in LOCAL position, the remote control cannot be operated.

●(D) Connector for AE-SW Drawout position switch (BIF-CL) connection

This connector is used for connection to BIF-CL (*Option).

For details about BIF-CL, see “*Instruction Manual for AE-SW Drawout position switch*”.

Wiring connection is shown as below.

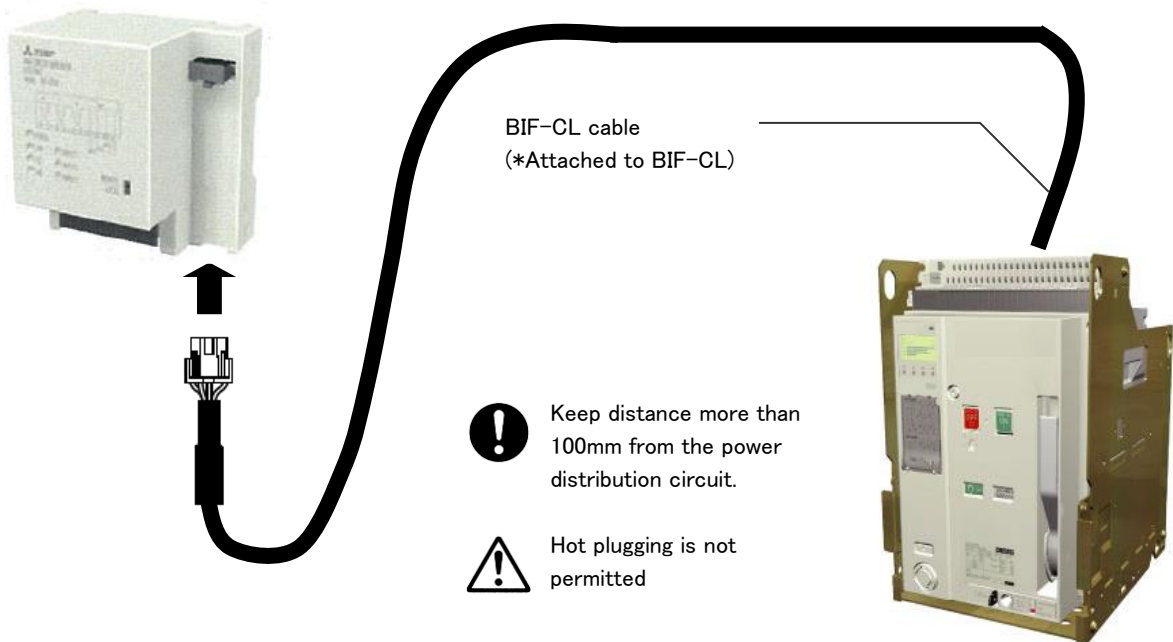

Fig 3.12: Wiring Connection

●(E) Connector for BIF-MD connection

This connector is used for connection to BIF-MD.
Wiring connection is shown as below.

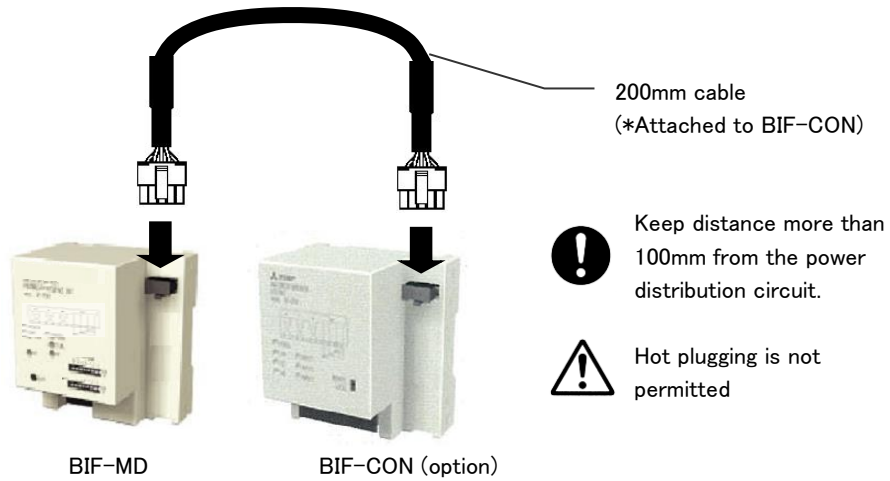

Fig 3.13 Wiring Connection

●(F) IEC rail latch

This is used to attach the BIF-CON to a IEC mounting rail.
IEC rail installation is shown in "4.1 IEC rail installation".

4. Installation

4.1 IEC rail installation

Installation of BIF-MD and BIF-CON on the 35mm IEC rail (DIN rail) is shown as below. The applicable IEC rail is shown in figure 4.1.

(A) Installation

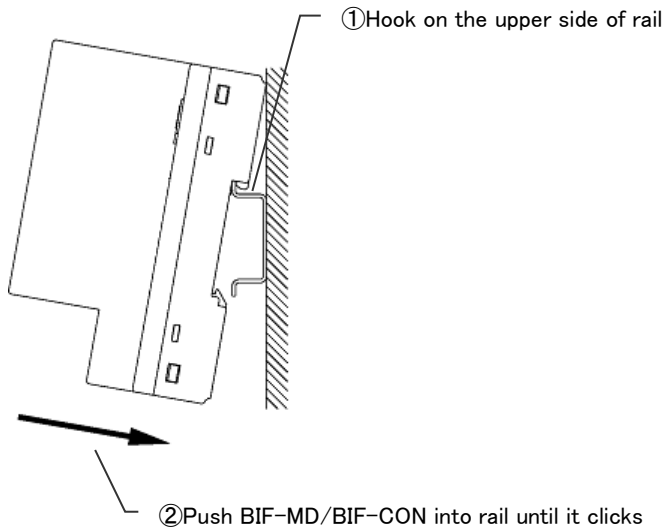

Fig 4.2: Installing

(B) Removing

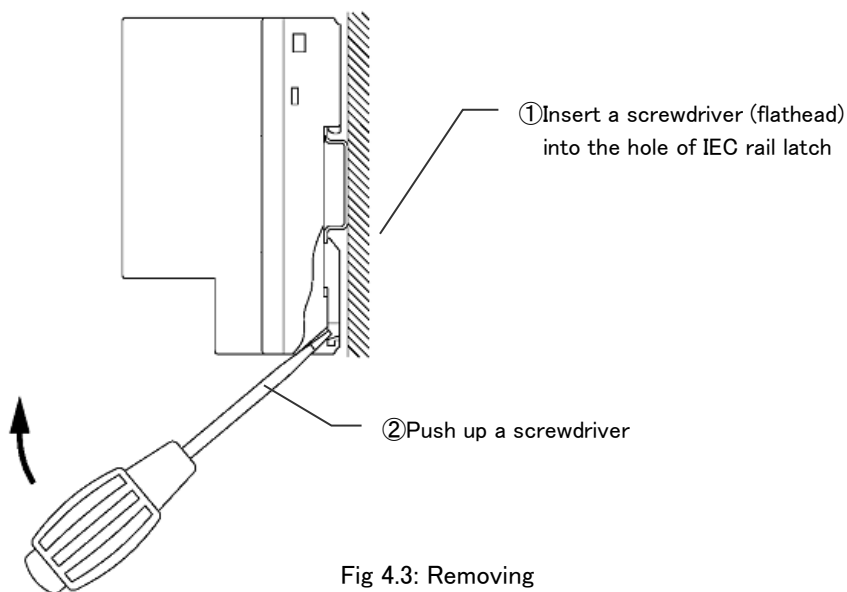

Fig 4.3: Removing

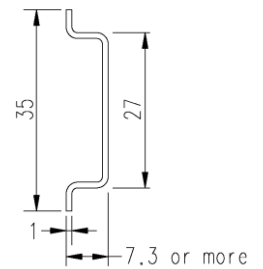

Fig 4.1: 35mm IEC rail

4.2 Bracket installation

Installation of BIF-MD and BIF-CON with the mounting bracket is shown as below.

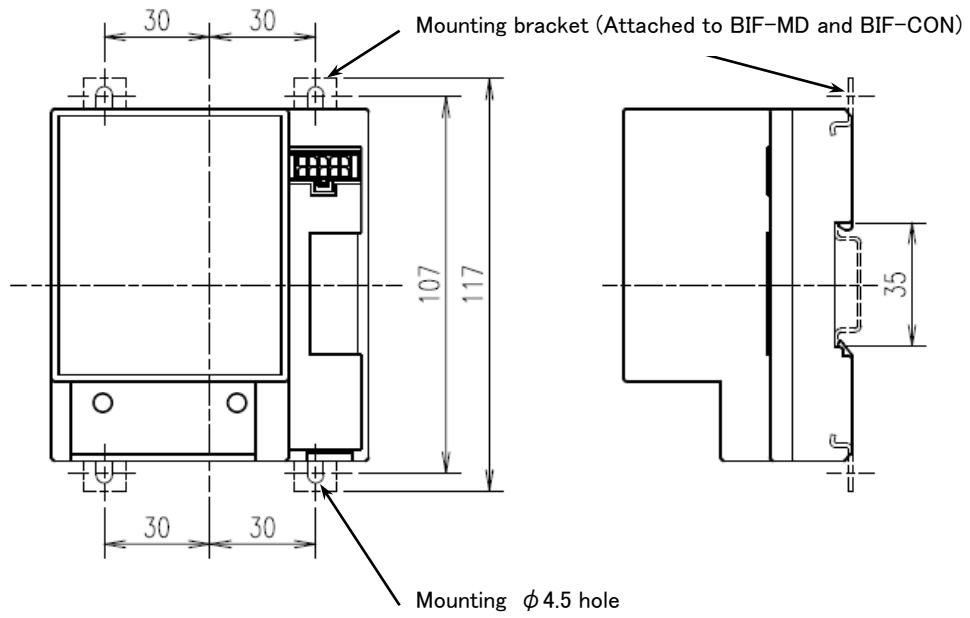

Fig 4.4: Mounting bracket Installation of BIF-MD, BIF-CON

5. MODBUS Data Format

For details, please download and refer to MODBUS over Serial Line Specification & Implementation guide from the following URL;
<http://www.ModBus.org/>

5.1 Standard frame

The standard communications frame consists of:

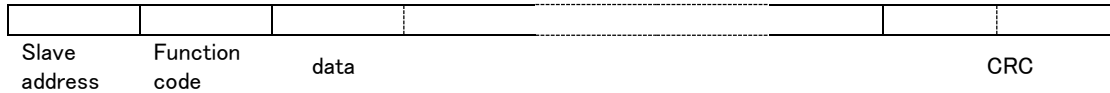

- Slave address : 01~7Fh
 *When selecting slave address 0, a message is sent to all the instruments present on the network. When the slave receives it, the slave does not make a response.
- Function code : 03h Read Holding Registers (maximum 250 bytes)
 : 08h Diagnostics
 : 10h Preset Multiple Registers
- DATA : 8 bit HEX data
- CRC : The Cyclical Redundancy Check (CRC) field is two bytes, containing a 16-bit binary value.

<NOTE>

A procedure for generating a CRC is:

1. Load a 16-bit register with FFFF HEX. Call this the CRC register.
2. Exclusive OR the first 8-bit byte of the message with the low-order byte of the 16-bit CRC register, putting the result in the CRC register.
3. Shift the CRC register one bit to the right (toward the LSB), zero-filling the MSB. Extract and examine the LSB.
4. (If the LSB was 0): Repeat Step 3 (another shift).
 (If the LSB was 1): Exclusive OR the CRC register with the polynomial value 0xA001 (1010 0000 0000 0001).
5. Repeat Steps 3 and 4 until 8 shifts have been performed. When this is done, a complete 8-bit byte will have been processed.
6. Repeat Steps 2 through 5 for the next 8-bit byte of the message. Continue doing this until all bytes have been processed.
7. The final content of the CRC register is the CRC value.
8. When the CRC is placed into the message, its upper and lower bytes must be swapped as described below.

5.2 Bit sequence

With RTU character framing, the bit sequence is:

<Example>With Parity Checking

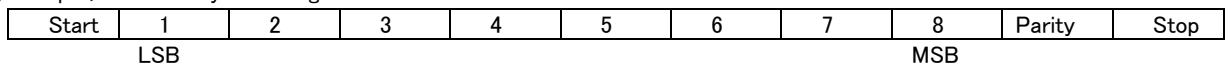

<Example>Without Parity Checking

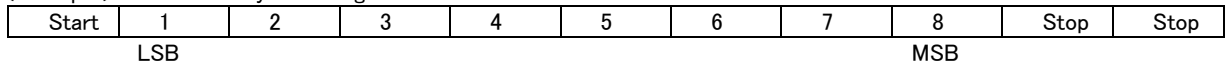

5.3 MODBUS Message RTU Framing

A MODBUS message is placed by the transmitting device into a frame that has a known beginning and ending point.

This allows devices that receive a new frame to begin at the start of the message, and to know when the message is completed. Partial messages must be detected and errors must be set as a result.

In RTU mode, message frames are separated by a silent interval of at least 3.5 character times.

The entire message frame must be transmitted as a continuous stream of characters.

If a silent interval of more than 1.5 character times occurs between two characters, the message frame is declared incomplete and should be discarded by the receiver.

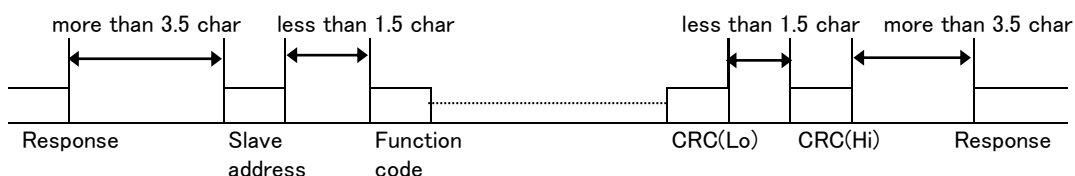

5.4 Framing of Query and Response

<Read Holding Registers (Function code : 03h)>

Query framing

**h	03h	Hi	Lo	Hi	Lo	Lo	Hi
-----	-----	----	----	----	----	----	----

Slave address Function Code Starting address quantity of registers CRC

- Slave address : 1~7Fh
- Starting address : 2 bytes
- Quantity of registers : Maximum 125
- CRC : 2 bytes

Response framing (Maximum 255 bytes)

**h	03h	Byte count	Hi	Lo	Hi	Lo	Lo	Hi
-----	-----	------------	----	----	----	----	----	----

Slave address Function Code data 1 data 2 CRC

- Byte count of response data : maximum 250

<Example> In case of monitoring from instantaneous current in Phase 1 (0300h) to apparent power (0326h).
Slave address : 01h

Query framing

01h	03h	03h	00h	00h	27h	Lo	Hi
-----	-----	-----	-----	-----	-----	----	----

Slave address Function Code Starting address quantity of registers CRC

Response framing

01h	03h	4Eh	H	L	H	L	H	L	Lo	Hi
-----	-----	-----	---	---	---	---	---	---	----	----

Slave Address Function Code Byte count I1 I2 Apparent Power CRC

<Preset Multiple Registers (Function code : 10h)>

Query framing (Maximum 255 bytes)

**h	10h	Hi	Lo	Hi	Lo	Hi	Lo	Hi	Lo	Hi	Lo	Hi
-----	-----	----	----	----	----	----	----	----	----	----	----	----

Slave address Function Code Starting address quantity of registers Byte count data 1 data 2 CRC

- Slave address : 0~7Fh, 0 means broadcasting.
- Starting address : 2 bytes
- quantity of registers : Maximum 123
- Byte count : Maximum 246
- Preset data : Minimum 2 bytes
- CRC : 2 bytes

Response framing (If the slave address is 0 (broadcast), a response is not made.)

**h	10h	Hi	Lo	Hi	Lo	Lo	Hi
-----	-----	----	----	----	----	----	----

Slave address Function Code starting address quantity of registers CRC

<Example> In case of setting from Date and time (YYMM) (20Eh) to Contact output(211h).
Slave address : 01h

Query framing

01h	10h	02h	0Eh	00h	04h	08h	H	L	H	L	H	L	H	L	Lo	Hi
-----	-----	-----	-----	-----	-----	-----	---	---	---	---	---	---	---	---	----	----

Slave address Function Code starting address quantity of registers Byte count YY MM DD HH MM SS Contact Output CRC

*BCD code

Response framing

01h	10h	02h	0Eh	00h	04h	Lo	Hi
-----	-----	-----	-----	-----	-----	----	----

Slave address Function Code starting address quantity of registers CRC

<Diagnostics (Function code :08h) (sub function code 00h)>

This function code is used for initial test of master's software.

Query framing

**h	08h	00h	00h	Hi	Lo	Lo	Hi
Slave address	Function Code	sub function code		data		CRC	
■	slave address			: 1 ~ 7Fh			
■	sub function code			: 00h			
■	data			: 2 bytes			
■	CRC			: 2 bytes			

Response framing

**h	08h	00h	00h	Hi	Lo	Lo	Hi
Slave address	Function Code	sub function code		data		CRC	
■	data			: same as the data of query			

5.5 MODBUS Exception Responses

ERROR	Meaning	Exception code	Display
Framing error	Query framing was incorrect.	No response is returned. Please retry with master software.	Modbus ERR. LED is turned ON (flashing) until receiving the correct query in case of no error.
Overrun error	1 byte data length was incorrect.		
Parity error	1 byte data was incorrect.		
CRC error	Framing data were incorrect.		
Illegal function	The function code received in the query was except 03h, 08h and 10h.	01	
Illegal data address	The data address received in the query is not an allowable address for the slave.	02	
Illegal data value	The data value received in the query is not an allowable data for the slave.	03	
Slave busy	Slave is busy on initial state or internal transmission *1 cable is not connected.	06	

*1 Addresses 02**h (0209h-02B9h) can be monitored even if internal transmission error has occurred.

Response framing

Slave address	function code *1	Exception code	Lo	Hi
**h	**h	**h	CRC	

*1 function code : In an exception response, the server sets the MSB of the function code to 1.

<Example>

function code in a query	function code in an exception response
03h	83h
08h	88h
10h	90h

⚠ CAUTION

Mitsubishi Electric Corporation puts the maximum effort into making electric products better and more reliable, but generally electric products may incorrect-operate under the influence of a noise etc.

In order not to cause abnormalities to a system by the influence of a noise etc., please retry 3 times or more with master software in case of error reply or no reply.

5.6 Register address

Table 5.6.1 Setting 1 register

Address		Number of bytes	Access	Register Name	Range	Unit	
DEC	HEX						
521	0209	2	R/W	Demand time for power	0 to 1800 *1	s	
522	020A	2	R/W	Demand time for current	0 to 1800 *1	s	
523	020B	2	R/W	Reset memory	Refer to table 5.6.3		
524	020C	2	R/W	Reserve			
525	020D	2	R/W	Demand time for earth leakage	0 to 1800 *1	s	
526	020E	2	R/W	Date and Time (Year and month.) (YY/MM, BCD code)	Year: 00 to 99, Month: 01 to 12,		
527	020F	2	R/W	Date and Time (Day and hour.) (DD/HH, BCD code)	Day: 01 to 31, Hour: 00 to 23,		
528	0210	2	R/W	Date and Time (Minute and second.) (MM/SS, BCD code)	Minute 00 to 59, Second: 00 to 59,		
529	0211	2	R/W	Contact output (ACB control)	Refer to table 5.6.5		
530	0212	2	R/W	Reserve			
531	0213	2	R/W	Reserve			
532	0214	2	R/W	Alarm holding method	Auto reset: 0000h Self – Holding: 0001h		
533	0215	2	R/W	Iep (earth leakage pre-alarm pickup current) *3	0 (non) to IΔn	mA	
534	0216	2	R/W	Tep (earth leakage pre-alarm delay time) *3	0(non) to 3000	ms	
535	0217	2	R	Ir	WS, WB	50 to 100	%
					WM (In = 250A to 315A)	0.625 x In to 1.0 x In	0.1A
					WM (In = 500A to 6300A)	0.625 x In to 1.0 x In	A
536	0218	2	R	Ip2 (2 nd additional pre-alarm pick-up current) *4	0(non) to 100	%	
537	0219	2	R	Tp2 (2 nd additional pre-alarm time) *4	0(non) to 1350	0.1s	
538	021A	2	R	Ip1 (pre-alarm pick-up current)	68 to 115	%	
539	021B	2	R	Reserve			
540	021C	2	R		WS, WB: Iu (uninterrupted current)	0(non) to 120	%
					WM: IL (LTD pickup current)		
541	021D	2	R	TL (LTD time)	0(non) to 150	s	
542	021E	2	R	Isd (STD pickup current)	0(non) to 1000	%	
543	021F	2	R	Tsd (STD time)	0(non) to 500	ms	
544	0220	2	R	Ii (INST pickup current)	200 to 1600	%	
545	0221	2	R		Ig (GFR pickup current) *5	0(non) to 100	%
					IΔn (ER pickup current) *3	0(non) to 10	A
546	0222	2	R		Tg (GFR time) *5	0(non) to 3000	ms
					Te (ER time) *3	0(non) to 3000	ms
547	0223	2	R	Characteristic bit data	Refer to table 5.6.6		
548	0224	2	R	NP (Neutral pole protection level)	50 to 100	%	
592	0250	2	R	In (CT rating)	250 to 6300	A	
593	0251	2	R	Contact input	Refer to table 5.6.4		
594	0252	2	R	Alarm and trip information	Refer to table 5.6.2		
595	0253	2	R	ETR Self diagnosis	Refer to table 5.6.7		
596	0254	2	R	Main setting module type	WS: 1h, WB: 4h, WM: 5h		
597	0255	2	R	Option setting module type	Non: 0h, AP: 1h, G1: 2h, E1: 3h		
698	02BA	2	R	ON/OFF Counter	0 to 65535		

*1 Data range: 0/10/20/30/40/50/60/120/180/240/300/360/420/480/540/600/660/720/780/840/900/1200/1800

*2 R/W: Read and write register. R : Read only register.

*3 E1 is needed

*4 AP is needed.

*5 G1 is needed.

*Addresses 02**h (0209h–02B9h) can be monitored even if internal transmission error has occurred.

Table 5.6.2 Alarm and Trip information

Bit	Name	0	1
b0	AX (ACB ON/OFF)	OFF	ON
b1	Reserve	—	—
b2	PAL2 P.U. Alarm	Non	Alarm
b3	PAL2 OUT Alarm	Non	Alarm
b4	PAL1 P.U. Alarm	Non	Alarm
b5	PAL1 OUT Alarm	Non	Alarm
b6	OVER Alarm	Non	Alarm
b7	LTD Trip	Non	Trip
b8	STD Trip	Non	Trip
b9	INST Trip	Non	Trip
b10	EPAL Alarm	Non	Alarm
b11	GFR(ER) Trip(Alarm)	Non	Trip(Alarm)
b12	UVT Trip	Non	Trip
b13	Reserve	—	—
b14	TAL Alarm	Non	Alarm
b15	Reserve	—	—

Table 5.6.3 Reset memory

Bit	Name	0	1
b0	Alarm and Trip info.	No reset	Reset
b1	All items	No reset	Reset
b2	All max. and min. measurement	No reset	Reset
b3	Reserve	—	—
b4	Reserve	—	—
b5	Reserve	—	—
b6	Reserve	—	—
b7	Alarm and trip history	No reset	Reset
b8	Reserve	—	—
b9	Reserve	—	—
b10	Reserve	—	—
b11	Reserve	—	—
b12	Reserve	—	—
b13	Reserve	—	—
b14	Wh and varh	No reset	Reset
b15	Reserve	—	—

*1 “All items (b1)” is to reset all items of b0, b2, b7 and b14.

Table 5.6.4 Contact input

Bit	Name	0	1
b0	Input 1 *1	OFF	ON
b1	Input 2 *1	OFF	ON
b2	Input 3 *1	OFF	ON
b3	Reserve	—	—
b4	Reserve	—	—
b5	Reserve	—	—
b6	Reserve	—	—
b7	Reserve	—	—
b8	Position of ACB *1*2	—	Disconnected
b9		—	Connected
b10		—	Test
b11	Reserve	—	—
b12	Reserve	—	—
b13	Reserve	—	—
b14	Reserve	—	—
b15	Reserve	—	—

*1 BIF-CON is needed.

*2 BIF-CL is needed.

Table 5.6.5 Contact output

Bit	Name	0	1
b0	SHT ON (ACB OFF) *1	OFF	ON
b1	CC ON (ACB ON) *1	OFF	ON
b2	MD ON (Charge Spring) *1	OFF	ON
b3	Reserve	—	—
b4	Reserve	—	—
b5	Reserve	—	—
b6	Reserve	—	—
b7	Reserve	—	—
b8	Reserve	—	—
b9	Reserve	—	—
b10	Reserve	—	—
b11	Reserve	—	—
b12	Reserve	—	—
b13	Reserve	—	—
b14	Reserve	—	—
b15	Reserve	—	—

*1 BIF-CON is needed.

Table 5.6.6 Characteristic bit data

Bit	Name	0	1
b0	Tg (Te) Alarm or Trip *1	Alarm	Trip
b1	I ^t of STD	OFF	ON
b2	MCR or INST	INST	MCR
b3	I ^t of PAL2 (AP) *2	OFF(Flat)	ON (I ^t)
b4	Reserve	—	—
b5	Reserve	—	—
b6	Reserve	—	—
b7	Position	—	—
b8	Reserve	—	—
b9	Reserve	—	—
b10	Reserve	—	—
b11	Reserve	—	—
b12	Reserve	—	—
b13	Reserve	—	—
b14	Reserve	—	—
b15	Reserve	—	—

*1 G1 (E1) is needed.

*2 AP is needed.

Table 5.6.7 ETR Self diagnosis

ETR Err. Type	Err. code
A/D converter Err.	11h
EEPROM Err.	12h
Date and Time IC (RTC) Err.	13h
Main setting module Err.	21h
Option setting module Err.	22h
CT Connector Err.	23h
MCR switch Err.	24h
TAL sensor Err.	25h
Voltage protection Err. *1	31h

*1 In case Voltage protection Trips happen 5 times continuously within 1 minute, it occurs.

***Some error mode may not be detected.**

Table 5.6.8 Trip history

Address		Number of bytes	Access	Register Name	Description	Unit
DEC	HEX					
598	0256	2	R	Trip history 1 (fault cause)	Refer to table 5.6.10	
599	0257	2	R	Trip history 1 (current/voltage)		*1 *2
600	0258	2	R	Trip history 1 (year and month)	YYMM. BCD code	
601	0259	2	R	Trip history 1 (day and hour)	DDHH. BCD code	
602	025A	2	R	Trip history 1 (minute and second.)	MMSS. BCD code	
603	025B	2	R	Trip history 2 (fault cause)	Refer to table 5.6.10	
604	025C	2	R	Trip history 2 (current/voltage)		*1 *2
605	025D	2	R	Trip history 2 (year and month)	YYMM. BCD code	
606	025E	2	R	Trip history 2 (day and hour)	DDHH. BCD code	
607	025F	2	R	Trip history 2 (minute and second)	MMSS. BCD code	
608	0260	2	R	Trip history 3 (fault cause)	Refer to table 5.6.10	
609	0261	2	R	Trip history 3 (current/voltage)		*1 *2
610	0262	2	R	Trip history 3 (year and month)	YYMM. BCD code	
611	0263	2	R	Trip history 3 (day and hour)	DDHH. BCD code	
612	0264	2	R	Trip history 3 (minute and second)	MMSS. BCD code	
613	0265	2	R	Trip history 4 (fault cause)	Refer to table 5.6.10	
614	0266	2	R	Trip history 4 (current/voltage)		*1 *2
615	0267	2	R	Trip history 4 (year and month)	YYMM. BCD code	
616	0268	2	R	Trip history 4 (day and hour)	DDHH. BCD code	
617	0269	2	R	Trip history 4 (minute and second)	MMSS. BCD code	
618	026A	2	R	Trip history 5 (fault cause)	Refer to table 5.6.10	
619	026B	2	R	Trip history 5 (current/voltage)		*1 *2
620	026C	2	R	Trip history 5 (year and month)	YYMM. BCD code	
621	026D	2	R	Trip history 5 (day and hour)	DDHH. BCD code	
622	026E	2	R	Trip history 5 (minute and second)	MMSS. BCD code	
623	026F	2	R	Trip history 6 (fault cause)	Refer to table 5.6.10	
624	0270	2	R	Trip history 6 (current/voltage)		*1 *2
625	0271	2	R	Trip history 6 (year and month)	YYMM. BCD code	
626	0272	2	R	Trip history 6 (day and hour)	DDHH. BCD code	
627	0273	2	R	Trip history 6 (minute and second)	MMSS. BCD code	
628	0274	2	R	Trip history 7 (fault cause)	Refer to table 5.6.10	
629	0275	2	R	Trip history 7 (current/voltage)		*1 *2
630	0276	2	R	Trip history 7 (year and month)	YYMM. BCD code	
631	0277	2	R	Trip history 7 (day and hour)	DDHH. BCD code	
632	0278	2	R	Trip history 7 (minute and second)	MMSS. BCD code	
633	0279	2	R	Trip history 8 (fault cause)	Refer to table 5.6.10	
634	027A	2	R	Trip history 8 (current/voltage)		*1 *2
635	027B	2	R	Trip history 8 (year and month)	YYMM. BCD code	
636	027C	2	R	Trip history 8 (day and hour)	DDHH. BCD code	
637	027D	2	R	Trip history 8 (minute and second)	MMSS. BCD code	
638	027E	2	R	Trip history 9 (fault cause)	Refer to table 5.6.10	
639	027F	2	R	Trip history 9 (current/voltage)		*1 *2
640	0280	2	R	Trip history 9 (year and month)	YYMM. BCD code	
641	0281	2	R	Trip history 9 (day and hour)	DDHH. BCD code	
642	0282	2	R	Trip history 9 (minute and second)	MMSS. BCD code	
643	0283	2	R	Trip history 10 (fault cause)	Refer to table 5.6.10	
644	0284	2	R	Trip history 10 (current/voltage)		*1 *2
645	0285	2	R	Trip history 10 (year and month)	YYMM. BCD code	
646	0286	2	R	Trip history 10 (day and hour)	DDHH. BCD code	
647	0287	2	R	Trip history 10 (minute and second)	MMSS. BCD code	

*1 In case of "LTD, STD, INST", Unit: 10A. In case of "GFR", Unit: 1A. In case of "ER", Unit: 0.1A.

In case of "UV, OV", Unit: 1V. In case of "UB", Unit: 1%.

*2 In case of UVT trip, there is no current information (current is 0).

*When power supply of power supply module (P1-P5) is off, trip and alarm history are not stored.

*Trip history 1 is the latest trip information. And trip history 10 is the oldest trip information.

*Addresses 02**h (0209h-02B9h) can be monitored even if internal transmission error has occurred.

Table 5.6.9 Alarm history

Address		Number of bytes	Access	Register Name	Range	Unit
DEC	HEX					
648	0288	2	R	Alarm history 1(alarm cause)	Refer to table 5.6.11	
649	0289	2	R	Reserve		
650	028A	2	R	Alarm history 1 (year and month)	YYMM. BCD code	
651	028B	2	R	Alarm history 1 (day and hour)	DDHH. BCD code	
652	028C	2	R	Alarm history 1 (minute and second)	MMSS. BCD code	
653	028D	2	R	Alarm history 2 (alarm cause)	Refer to table 5.6.11	
654	028E	2	R	Reserve		
655	028F	2	R	Alarm history 2 (year and month)	YYMM. BCD code	
656	0290	2	R	Alarm history 2 (day and hour)	DDHH. BCD code	
657	0291	2	R	Alarm history 2 (minute and second)	MMSS. BCD code	
658	0292	2	R	Alarm history 3 (alarm cause)	Refer to table 5.6.11	
659	0293	2	R	Reserve		
660	0294	2	R	Alarm history 3 (year and month)	YYMM. BCD code	
661	0295	2	R	Alarm history 3 (day and hour)	DDHH. BCD code	
662	0296	2	R	Alarm history 3 (minute and second)	MMSS. BCD code	
663	0297	2	R	Alarm history 4 (alarm cause)	Refer to table 5.6.11	
664	0298	2	R	Reserve		
665	0299	2	R	Alarm history 4 (year and month)	YYMM. BCD code	
666	029A	2	R	Alarm history 4 (day and hour)	DDHH. BCD code	
667	029B	2	R	Alarm history 4 (minute and second)	MMSS. BCD code	
668	029C	2	R	Alarm history 5 (alarm cause)	Refer to table 5.6.11	
669	029D	2	R	Reserve		
670	029E	2	R	Alarm history 5 (year and month)	YYMM. BCD code	
671	029F	2	R	Alarm history 5 (day and hour)	DDHH. BCD code	
672	02A0	2	R	Alarm history 5 (minute and second)	MMSS. BCD code	
673	02A1	2	R	Alarm history 6 (alarm cause)	Refer to table 5.6.11	
674	02A2	2	R	Reserve		
675	02A3	2	R	Alarm history 6 (year and month)	YYMM. BCD code	
676	02A4	2	R	Alarm history 6 (day and hour)	DDHH. BCD code	
677	02A5	2	R	Alarm history 6 (minute and second)	MMSS. BCD code	
678	02A6	2	R	Alarm history 7 (alarm cause)	Refer to table 5.6.11	
679	02A7	2	R	Reserve		
680	02A8	2	R	Alarm history 7 (year and month)	YYMM. BCD code	
681	02A9	2	R	Alarm history 7 (day and hour)	DDHH. BCD code	
682	02AA	2	R	Alarm history 7 (minute and second)	MMSS. BCD code	
683	02AB	2	R	Alarm history 8 (alarm cause)	Refer to table 5.6.11	
684	02AC	2	R	Reserve		
685	02AD	2	R	Alarm history 8 (year and month)	YYMM. BCD code	
686	02AE	2	R	Alarm history 8 (day and hour)	DDHH. BCD code	
687	02AF	2	R	Alarm history 8 (minute and second)	MMSS. BCD code	
688	02B0	2	R	Alarm history 9 (alarm cause)	Refer to table 5.6.11	
689	02B1	2	R	Reserve		
690	02B2	2	R	Alarm history 9 (year and month)	YYMM. BCD code	
691	02B3	2	R	Alarm history 9 (day and hour)	DDHH. BCD code	
692	02B4	2	R	Alarm history 9 (minute and second)	MMSS. BCD code	
693	02B5	2	R	Alarm history 10 (alarm cause)	Refer to table 5.6.11	
694	02B6	2	R	Reserve		
695	02B7	2	R	Alarm history 10 (year and month)	YYMM. BCD code	
696	02B8	2	R	Alarm history 10 (day and hour)	DDHH. BCD code	
697	02B9	2	R	Alarm history 10 (minute and second)	MMSS. BCD code	

* When the alarm holding method is set to “Auto Reset”, all alarms are not monitored and are not stored in EEPROM. When the alarm holding method is set to “Self-Holding”, all alarms except for PAL1 P.U., PAL2 P.U. and OVER can be monitored and can be stored in EEPROM.

Alarm holding method can be monitored and set by address 0214h.

*When power supply of power supply module (P1-P5) is off, trip and alarm history are not stored.

*Alarm history 1 is the latest alarm information. And alarm history 10 is the oldest alarm information.

*Addresses 02**h (0209h-02B9h) can be monitored even if internal transmission error has occurred.

Table 5.6.10 Trip history fault cause

Bit	Name	0	1
b0	UV Trip	Non	Trip
b1	OV Trip	Non	Trip
b2	UB Trip	Non	Trip
b3	Reserve	—	—
b4	Reserve	—	—
b5	Reserve	—	—
b6	Reserve	—	—
b7	LTD Trip	Non	Trip
b8	STD Trip	Non	Trip
b9	INST Trip	Non	Trip
b10	Reserve	—	—
b11	GFR/ER Trip	Non	Trip
b12	UVT Trip	Non	Trip
b13	Reserve	—	—
b14	Reserve	—	—
b15	Reserve	—	—

Table 5.6.11 Alarm history cause

Bit	Name	0	1
b0	UV Alarm	Non	Alarm
b1	OV Alarm	Non	Alarm
b2	UB Alarm	Non	Alarm
b3	PAL2 OUT Alarm	Non	Alarm
b4	Reserve	—	—
b5	PAL1 OUT Alarm	Non	Alarm
b6	Reserve	—	—
b7	Reserve	—	—
b8	Reserve	—	—
b9	Reserve	—	—
b10	EPAL Alarm	Non	Alarm
b11	GFR/ER Alarm	Non	Alarm
b12	Reserve	—	—
b13	Reserve	—	—
b14	TAL Alarm	Non	Alarm
b15	Reserve	—	—

*1 PAL2 P.U., PAL1 P.U., and OVER is not included in alarm history.

Table 5.6.12 analog measurement 1 register

Address		Number of bytes	Access	Register Name	Unit	Range
DEC	HEX					
768	0300	2	R	Instantaneous current in Phase 1 (I1) *1	*4	Refer to table 2.4
769	0301	2	R	Instantaneous current in Phase 2 (I2) *1		
770	0302	2	R	Instantaneous current in Phase 3 (I3) *1		
771	0303	2	R	Instantaneous current in Pole N (IN) *1,2		
772	0304	2	R	Reserved		
773	0305	2	R	Demand current in Phase 1 (I1) *1	*4	
774	0306	2	R	Demand current in Phase 2 (I2) *1		
775	0307	2	R	Demand current in Phase 3 (I3) *1		
776	0308	2	R	Demand current in Pole N (IN) *1,2		
777	0309	2	R	Reserved		
778	030A	2	R	Instantaneous voltage in Line 1-2 (V12)	V	
779	030B	2	R	Instantaneous voltage in Line 2-3 (V23)		
780	030C	2	R	Instantaneous voltage in Line 1-3 (V13)		
781	030D	2	R	Reserved		
782	030E	2	R	Instantaneous voltage in Phase 1-N (V1N) *2	V	
783	030F	2	R	Instantaneous voltage in Phase 2-N (V2N) *2		
784	0310	2	R	Instantaneous voltage in Phase 3-N (V3N) *2		
785	0311	2	R	Reserved		
786	0312	2	R	Reserved		
787	0313	2	R	Reserved		
788	0314	2	R	Reserved		
789	0315	2	R	Instantaneous power Factor *6	0.1%	
790	0316	2	R	Instantaneous frequency	Hz	
791	0317	2	R	Reserved		
792	0318	2	R	Reserved		
793	0319	2	R	Reserved		
794	031A	2	R	Instantaneous active power *6	*5	
795	031B	2	R	Reserved		
796	031C	2	R	Reserved		
797	031D	2	R	Reserved		
798	031E	2	R	Demand active power *6	*5	
799	031F	2	R	Reserved		
800	0320	2	R	Reserved		
801	0321	2	R	Reserved		
802	0322	2	R	Instantaneous reactive power *6	*5	
803	0323	2	R	Reserved		
804	0324	2	R	Reserved		
805	0325	2	R	Reserved		
806	0326	2	R	Instantaneous apparent power	*5	
807	0327	2	R	Demand reactive power *6	*5	
808	0328	2	R	Demand apparent power	*5	
809	0329	2	R	Instantaneous earth leakage (I _g) *1,3	0.1A	
810	032A	2	R	Demand earth leakage (I _g) *1,3	0.1A	
811	032B	2	R	Fault current/voltage *8	*7	

*1 Only data of current (from 300h to 308h) and earth leakage (032Ah, 032Bh) can be monitored without VT unit.

*2 In case of 3 ϕ 3W, N Pole measurements (303h, 308h, 30Eh to 310h) cannot be monitored.

*3 Earth leakage (32Ah, 32Bh) cannot be monitored without E1 module.

*4 In case of "In=250 to 315", Unit: 0.1A. In case of "In=500 to 6300", Unit: 1A.

*5 In case of "In=250 to 630", Unit: 0.1kW, 0.1kvar, 0.1kVA. In case of "In=1000 to 6300", Unit: 1kW, 1kvar, 1kVA.

*6 Minus data is expressed as two's complement.

*7 In case of "LTD, STD, INST", Unit: 10A. In case of "GFR", Unit: 1A. In case of "ER", Unit: 0.1A.

In case of "UV, OV", Unit: 1V. In case of "UB", Unit: 1%.

Fault cause can be monitored with Alarm and trip information (0252h).

*8 In case of "UVT", Data: non (0).

Table 5.6.13 analog measurement 2 register

Address		Number of bytes	Access	Register Name	Unit	Range
DEC	HEX					
812	032C	2	R	Max. instantaneous current in Phase 1 (I1) *1	*3	Refer to table 2.4
813	032D	2	R	Max. instantaneous current in Phase 2 (I2) *1		
814	032E	2	R	Max. instantaneous current in Phase 3 (I3) *1		
815	032F	2	R	Max. instantaneous current in Pole N (IN) *1		
816	0330	2	R	Reserved		
817	0331	2	R	Max. demand current in Phase 1 (I1) *1	*3	
818	0332	2	R	Max. demand current in Phase 2 (I2) *1		
819	0333	2	R	Max. demand current in Phase 3 (I3) *1		
820	0334	2	R	Max. demand current in Pole N (IN) *1		
821	0335	2	R	Reserved		
822	0336	2	R	Max. demand current in Max. Phase	*3	
823	0337	2	R	Max. instantaneous voltage in Line 1-2 (V12)	V	
824	0338	2	R	Max. instantaneous voltage in Line 2-3 (V23)		
825	0339	2	R	Max. instantaneous voltage in Line 1-3 (V13)		
826	033A	2	R	Reserved		
827	033B	2	R	Max. instantaneous voltage in Max. Line		
828	033C	2	R	Max. instantaneous voltage in Phase 1-N (V1N)	V	
829	033D	2	R	Max. instantaneous voltage in Phase 2-N (V2N)		
830	033E	2	R	Max. instantaneous voltage in Phase 3-N (V1N)		
831	033F	2	R	Reserved		
832	0340	2	R	Max. instantaneous voltage in Max. Phase	V	
833	0341	2	R	Reserved		
834	0342	2	R	Reserved		
835	0343	2	R	Reserved		
836	0344	2	R	Max. instantaneous power Factor *5	0.1%	
837	0345	2	R	Reserved		
838	0346	2	R	Reserved		
839	0347	2	R	Reserved		
840	0348	2	R	Reserved		
841	0349	2	R	Max. instantaneous active power *5	*4	
842	034A	2	R	Reserved		
843	034B	2	R	Reserved		
844	034C	2	R	Reserved		
845	034D	2	R	Max. demand active power *5	*4	
846	034E	2	R	Reserved		
847	034F	2	R	Reserved		
848	0350	2	R	Reserved		
849	0351	2	R	Max. instantaneous reactive power *5	*4	
850	0352	2	R	Reserved		
851	0353	2	R	Reserved		
852	0354	2	R	Reserved		
853	0355	2	R	Max. instantaneous apparent power	*4	
854	0356	2	R	Max. demand reactive power *5	*4	
855	0357	2	R	Max. demand apparent power	*4	
856	0358	2	R	Max. instantaneous earth leakage(Ig) *1,6	0.1A	
857	0359	2	R	Max. demand earth leakage (Ig) *1,6	0.1A	

*1 Only data of current (from 32Ch to 336h) and earth leakage (0358h, 0359h) can be monitored without VT unit.

*2 In case of 3 ϕ 3W, N Pole measurements (32Fh, 334h, 33Ch to 33Eh) cannot be monitored.

*3 In case of "In=250 to 315", Unit: 0.1A. In case of "In=500 to 6300", Unit: 1A.

*4 In case of "In=250 to 630", Unit: 0.1kW, 0.1kvar, 0.1kVA. In case of "In=1000 to 6300", Unit: 1kW, 1kvar, 1kVA.

*5 Minus data is expressed as two's complement.

*6 Earth leakage (0358h, 0359h) cannot be monitored without E1 module.

*All max. items are saved in EEPROM of EX1 module every 2 hours.

Table 5.6.14 analog measurement 3 register

Address		Number of bytes	Access	Register Name	Unit	Range
DEC	HEX					
858	035A	2	R	Reserved		Refer to table 2.4
859	035B	2	R	Reserved		
860	035C	2	R	Reserved		
861	035D	2	R	Reserved		
862	035E	2	R	Reserved		
863	035F	2	R	Reserved		
864	0360	2	R	Reserved		
865	0361	2	R	Reserved		
866	0362	2	R	Reserved		
867	0363	2	R	Reserved		
868	0364	2	R	Reserved		
869	0365	2	R	Reserved		
870	0366	2	R	Reserved		
871	0367	2	R	Reserved		
872	0368	2	R	Reserved		
873	0369	2	R	Reserved		
874	036A	2	R	Reserved		
875	036B	2	R	Reserved		
876	036C	2	R	Reserved		
877	036D	2	R	Reserved		
878	036E	2	R	Reserved		
879	036F	2	R	Min. Instantaneous power Factor *1 2 3	0.1%	
880	0370	2	R	Reserved		
881	0371	2	R	Reserved		
882	0372	2	R	Reserved		
883	0373	2	R	Reserved		
884	0374	2	R	Reserved		
885	0375	2	R	Reserved		
886	0376	2	R	Reserved		
887	0377	2	R	Reserved		
888	0378	2	R	Reserved		
889	0379	2	R	Reserved		
890	037A	2	R	Reserved		
891	037B	2	R	Reserved		
892	037C	2	R	Reserved		
893	037D	2	R	Reserved		
894	037E	2	R	Reserved		
895	037F	2	R	Reserved		
896	0380	2	R	Reserved		
897	0381	2	R	Reserved		
898	0382	2	R	Reserved		

*1 All above data cannot be monitored without EX1 and VT unit (VT).

*2 Minus data is expressed as two's complement.

*3 All min. items are saved in EEPROM of EX1 module every 2 hours.

Table 5.6.15 Setting 2 register

Address		Number of bytes	Access	Register Name	Range	Unit
DEC	HEX					
1149	047D	2	R	Alarm and trip information (Voltage protection) *1	Refer to table 5.6.16	
1170	0492	2	R	Main body temperature *2	Refer to table 2.4	°C
1171	0493	2	R/W	Operating voltage *1	Refer to table 2.3, 2.4	V
1172	0494	2	R/W	Characteristic bit data (Voltage protection) *1	Refer to table 5.6.17	
1173	0495	2	R/W	V_UV (UV pick-up voltage) *1	Refer to table 2.4	%
1174	0496	2	R/W	T_UV (UV time) *1	Refer to table 2.3	s
1175	0497	2	R/W	V_OV (OV pick-up voltage) *1	Refer to table 2.4	%
1176	0498	2	R/W	T_OV (OV time) *1	Refer to table 2.3	s
1177	0499	2	R/W	V_UB (UB pick-up voltage) *1	Refer to table 2.4	%
1178	049A	2	R/W	T_UB (UB time) *1	Refer to table 2.3	s

*1 This cannot be used when EX1 and VT unit (VT) are not equipped.

*2 TAL sensor is needed.

*In the following cases, 04**h (047Dh-049Ah) is not available.

•In case of module other than the specified serial number is connected

•In case of Electric trip relay (for protective coordination use : WF) is connected

Table 5.6.16 Alarm and Trip information (Voltage protection)

Bit	Name	0	1
b0	UV Trip(Alarm)	Non	Trip(Alarm)
b1	OV Trip(Alarm)	Non	Trip(Alarm)
b2	UB Trip(Alarm)	Non	Trip(Alarm)
b3	Reserve	—	—
b4	Reserve	—	—
b5	Reserve	—	—
b6	Reserve	—	—
b7	Reserve	—	—
b8	Reserve	—	—
b9	Reserve	—	—
b10	Reserve	—	—
b11	Reserve	—	—
b12	Reserve	—	—
b13	Reserve	—	—
b14	Reserve	—	—
b15	Reserve	—	—

Table 5.6.17 Characteristic bit data (Voltage protection)

Bit	Name	0	1
b0	UV Alarm or Trip	Alarm	Trip
b1	OV Alarm or Trip	Alarm	Trip
b2	UB Alarm or Trip	Alarm	Trip
b3	Reserve	—	—
b4	Reserve	—	—
b5	Reserve	—	—
b6	Reserve	—	—
b7	Reserve	—	—
b8	Reserve	—	—
b9	Reserve	—	—
b10	Reserve	—	—
b11	Reserve	—	—
b12	Reserve	—	—
b13	Reserve	—	—
b14	Reserve	—	—
b15	Reserve	—	—

Table 5.6.18 Energy register

Address		Number of bytes	Access	Register Name	Unit	Range
DEC	HEX					
1280	0500	2	R	Active energy	kWh	0 to 999
1281	0501	2	R		MWh	0 to 9999
1282	0502	2	R	Reserved		
1283	0503	2	R	Reserved		
1284	0504	2	R	Reactive energy (Lag)	kvarh	0 to 999
1285	0505	2	R		Mvarh	0 to 9999
1286	0506	2	R	Reserved		
1287	0507	2	R	Reserved		
1288	0508	2	R	Reactive energy (Lead)	kvarh	0 to 999
1289	0509	2	R		Mvarh	0 to 9999
1290	050A	2	R	Reserved		
1291	050B	2	R	Reserved		
1292	050C	2	R	Reserved		
1293	050D	2	R	Reserved		
1294	050E	2	R	Reserved		
1295	050F	2	R	Reserved		
1296	0510	2	R	Reserved		
1297	0511	2	R	Reserved		
1298	0512	2	R	Reserved		
1299	0513	2	R	Reserved		
1300	0514	2	R	Reserved		
1301	0515	2	R	Reserved		
1302	0516	2	R	Reserved		
1303	0517	2	R	Reserved		
1304	0518	4	R	Active energy (4 bytes) *1	kWh	0 to 99999999
1306	051A	4	R	Reserved		
1308	051C	4	R	Reactive energy (4 bytes) *1	kvarh	0 to 99999999
1310	051E	4	R	Reserved		
1312	0520	4	R	Reactive energy (4 bytes) *1	kvarh	0 to 99999999

*All above data cannot be monitored without EX1 and VT unit.

*The active and reactive energy are stored in the EEPROM of Extension module (EX1) when the power supply from Power supply module (P1-P5) is cut off.

*1 Addresses 0518h-0520h can be accessed only from the even number address.

If the byte count of start address 0518h and 051Ah etc. is 2, 3, 5, or 6-byte, the error code (illegal data address code :02h) is returned.

<Example> In case of monitoring active energy (0518h).

Slave address :01h

Query framing

01h	03h	05h	18h	00h	02h	Lo	Hi
Slave address	Function Code	Starting address		quantity of registers		CRC	

Response framing

01h	03h	04h	HH	HL	LH	LL	Lo	Hi
Slave Address	Function Code	Byte count	Active energy				CRC	

Table 5.6.19 Harmonics 1 register

Address		Number of bytes	Access	Register Name	Unit	RANGE
DEC	HEX					
2304	0900	2	R	Total harmonics current in Phase 1 (I1)	*1	0 to 2xIn
2305	0901	2	R	Total harmonics current in Phase 2 (I2)		
2306	0902	2	R	Total harmonics current in Phase 3 (I3)		
2307	0903	2	R	Total harmonics current in Pole N (IN)		
2308	0904	2	R	Fundamental current in Phase 1 (I1)		
2309	0905	2	R	Fundamental current in Phase 2 (I2)		
2310	0906	2	R	Fundamental current in Phase 3 (I3)		
2311	0907	2	R	Fundamental current in Pole N (IN)		
2312	0908	2	R	3 rd harmonics current in Phase 1 (I1)		
2313	0909	2	R	3 rd harmonics current in Phase 2 (I2)		
2314	090A	2	R	3 rd harmonics current in Phase 3 (I3)		
2315	090B	2	R	3 rd harmonics current in Pole N (IN)		
2316	090C	2	R	5 th harmonics current in Phase 1 (I1)		
2317	090D	2	R	5 th harmonics current in Phase 2 (I2)		
2318	090E	2	R	5 th harmonics current in Phase 3 (I3)		
2319	090F	2	R	5 th harmonics current in Pole N (IN)		
2320	0910	2	R	7 th harmonics current in Phase 1 (I1)		
2321	0911	2	R	7 th harmonics current in Phase 2 (I2)		
2322	0912	2	R	7 th harmonics current in Phase 3 (I3)		
2323	0913	2	R	7 th harmonics current in Pole N (IN)		
2324	0914	2	R	9 th harmonics current in Phase 1 (I1)		
2325	0915	2	R	9 th harmonics current in Phase 2 (I2)		
2326	0916	2	R	9 th harmonics current in Phase 3 (I3)		
2327	0917	2	R	9 th harmonics current in Pole N (IN)		
2328	0918	2	R	11 th harmonics current in Phase 1 (I1)		
2329	0919	2	R	11 th harmonics current in Phase 2 (I2)		
2330	091A	2	R	11 th harmonics current in Phase 3 (I3)		
2331	091B	2	R	11 th harmonics current in Pole N (IN)		
2332	091C	2	R	13 th harmonics current in Phase 1 (I1)		
2333	091D	2	R	13 th harmonics current in Phase 2 (I2)		
2334	091E	2	R	13 th harmonics current in Phase 3 (I3)		
2335	091F	2	R	13 th harmonics current in Pole N (IN)		
2336	0920	2	R	15 th harmonics current in Phase 1 (I1)		
2337	0921	2	R	15 th harmonics current in Phase 2 (I2)		
2338	0922	2	R	15 th harmonics current in Phase 3 (I3)		
2339	0923	2	R	15 th harmonics current in Pole N (IN)		
2340	0924	2	R	17 th harmonics current in Phase 1 (I1)		
2341	0925	2	R	17 th harmonics current in Phase 2 (I2)		
2342	0926	2	R	17 th harmonics current in Phase 3 (I3)		
2343	0927	2	R	17 th harmonics current in Pole N (IN)		
2344	0928	2	R	19 th harmonics current in Phase 1 (I1)		
2345	0929	2	R	19 th harmonics current in Phase 2 (I2)		
2346	092A	2	R	19 th harmonics current in Phase 3 (I3)		
2347	092B	2	R	19 th harmonics current in Pole N (IN)		

*1 In case of "In=250 to 315", Unit: 0.1A. In case of "In=500 to 6300", Unit: 1A.

*All above data cannot be monitored without EX1 and VT unit.

Table 5.6.20 Harmonics 2 register

Address		Number of bytes	Access	Register Name	Unit	RANGE
DEC	HEX					
3072	0C00	2	R	THD (total harmonics distortion) current in Phase 1 (I1)	0.1%	0 to 2000 (200%)
3073	0C01	2	R	THD (total harmonics distortion) current in Phase 1 (I2)		
3074	0C02	2	R	THD (total harmonics distortion) current in Phase 1 (I3)		
3075	0C03	2	R	THD (total harmonics distortion) current in Pole N (IN)		
3076	0C04	2	R	3 rd harmonics ratio current in Phase 1 (I1)		
3077	0C05	2	R	3 rd harmonics ratio current in Phase 2 (I2)		
3078	0C06	2	R	3 rd harmonics ratio current in Phase 3 (I3)		
3079	0C07	2	R	3 rd harmonics ratio current in Pole N (IN)		
3080	0C08	2	R	5 th harmonics ratio current in Phase 1 (I1)		
3081	0C09	2	R	5 th harmonics ratio current in Phase 2 (I2)		
3082	0C0A	2	R	5 th harmonics ratio current in Phase 3 (I3)		
3083	0C0B	2	R	5 th harmonics ratio current in Pole N (IN)		
3084	0C0C	2	R	7 th harmonics ratio current in Phase 1 (I1)		
3085	0C0D	2	R	7 th harmonics ratio current in Phase 2 (I2)		
3086	0C0E	2	R	7 th harmonics ratio current in Phase 3 (I3)		
3087	0C0F	2	R	7 th harmonics ratio current in Pole N (IN)		
3088	0C10	2	R	9 th harmonics ratio current in Phase 1 (I1)		
3089	0C11	2	R	9 th harmonics ratio current in Phase 2 (I2)		
3090	0C12	2	R	9 th harmonics ratio current in Phase 3 (I3)		
3091	0C13	2	R	9 th harmonics ratio current in Pole N (IN)		
3092	0C14	2	R	11 th harmonics ratio current in Phase 1 (I1)		
3093	0C15	2	R	11 th harmonics ratio current in Phase 2 (I2)		
3094	0C16	2	R	11 th harmonics ratio current in Phase 3 (I3)		
3095	0C17	2	R	11 th harmonics ratio current in Pole N (IN)		
3096	0C18	2	R	13 th harmonics ratio current in Phase 1 (I1)		
3097	0C19	2	R	13 th harmonics ratio current in Phase 2 (I2)		
3098	0C1A	2	R	13 th harmonics ratio current in Phase 3 (I3)		
3099	0C1B	2	R	13 th harmonics ratio current in Pole N (IN)		
3100	0C1C	2	R	15 th harmonics ratio current in Phase 1 (I1)		
3101	0C1D	2	R	15 th harmonics ratio current in Phase 2 (I2)		
3102	0C1E	2	R	15 th harmonics ratio current in Phase 3 (I3)		
3103	0C1F	2	R	15 th harmonics ratio current in Pole N (IN)		
3104	0C20	2	R	17 th harmonics ratio current in Phase 1 (I1)		
3105	0C21	2	R	17 th harmonics ratio current in Phase 2 (I2)		
3106	0C22	2	R	17 th harmonics ratio current in Phase 3 (I3)		
3107	0C23	2	R	17 th harmonics ratio current in Pole N (IN)		
3108	0C24	2	R	19 th harmonics ratio current in Phase 1 (I1)		
3109	0C25	2	R	19 th harmonics ratio current in Phase 2 (I2)		
3110	0C26	2	R	19 th harmonics ratio current in Phase 3 (I3)		
3111	0C27	2	R	19 th harmonics ratio current in Pole N (IN)		

*All above data cannot be monitored without EX1 and VT unit.

Table 5.6.21 Harmonics 3 register

Address		Number of bytes	Access	Register Name	Unit	RANGE
DEC	HEX					
3840	0F00	2	R	Max. total harmonics current in Max. Phase	*1	0 to 2xIn
3841	0F01	2	R	Max. fundamental current in Max. Phase		
3842	0F02	2	R	Max. 3 rd harmonics current in Max. Phase		
3843	0F03	2	R	Max. 5 th harmonics current in Max. Phase		
3844	0F04	2	R	Max. 7 th harmonics current in Max. Phase		
3845	0F05	2	R	Max. 9 th harmonics current in Max. Phase		
3846	0F06	2	R	Max. 11 th harmonics current in Max. Phase		
3847	0F07	2	R	Max. 13 th harmonics current in Max. Phase		
3848	0F08	2	R	Max. 15 th harmonics current in Max. Phase		
3849	0F09	2	R	Max. 17 th harmonics current in Max. Phase		
3850	0F0A	2	R	Max. 19 th harmonics current in Max. Phase		
4608	1200	2	R	Max. THD (total harmonics distortion) current in Max. Phase	0.1%	0 to 2000 (200%)
4609	1201	2	R	Max. 3 rd harmonics ratio current in Max. Phase		
4610	1202	2	R	Max. 5 th harmonics ratio current in Max. Phase		
4611	1203	2	R	Max. 7 th harmonics ratio current in Max. Phase		
4612	1204	2	R	Max. 9 th harmonics ratio current in Max. Phase		
4613	1205	2	R	Max. 11 th harmonics ratio current in Max. Phase		
4614	1206	2	R	Max. 13 th harmonics ratio current in Max. Phase		
4615	1207	2	R	Max. 15 th harmonics ratio current in Max. Phase		
4616	1208	2	R	Max. 17 th harmonics ratio current in Max. Phase		
4617	1209	2	R	Max. 19 th harmonics ratio current in Max. Phase		

*1 In case of "In=250 to 315", Unit: 0.1A. In case of "In=500 to 6300", Unit: 1A.

*All above data cannot be monitored without EX1 and VT unit.

*All maximum items are saved in EEPROM of EX1 module every 2 hours.

*Max. means maximum value from past when the item is reset to present.

Max. ratio (Max. THD) is defined as a value when the RMS is maximum.

6. Outline dimensions

● BIF-MD

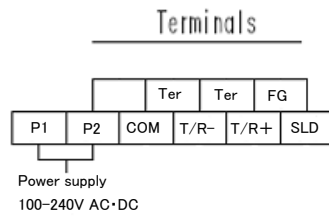
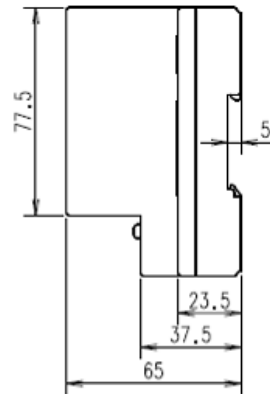
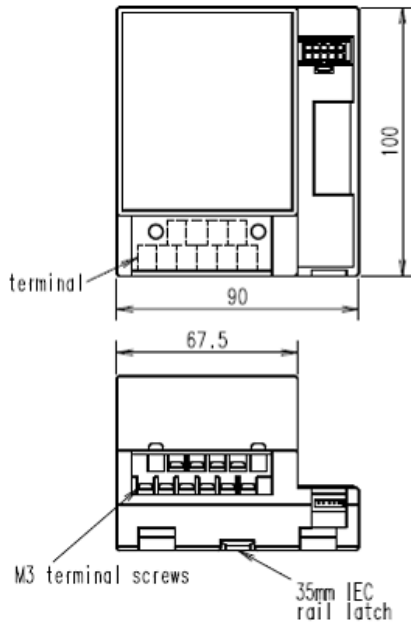

● BIF-CON

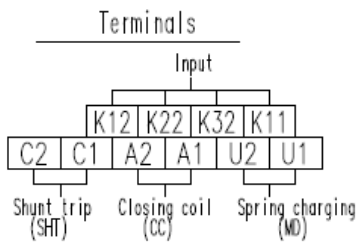
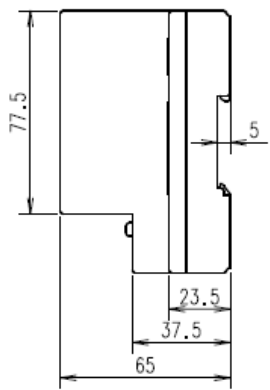
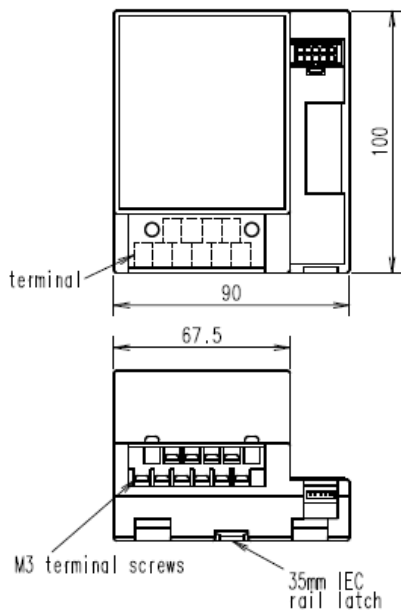

三菱低圧気中遮断器 AE 形

MITSUBISHI Low-Voltage Air Circuit Breakers type AE

三菱低圧空气断路器 AE 系列

MODBUS インタフェースユニット(BIF-MD)

MODBUS Interface unit (BIF-MD)

MODBUS 接口模块(BIF-MD)

MITSUBISHI ELECTRIC CORPORATION

東京都千代田区丸の内 2-7-3 (東京ビル) 〒100-8310

HEAD OFFICE: TOKYO BLDG., MARUNOUCHI, 2-7-3, CHIYODAKU, TOKYO 100-8310. TELEX: J24532 CABLE: MELCO TOKYO