

FACTORY AUTOMATION

# Low Voltage Circuit Breakers

(General Catalog)

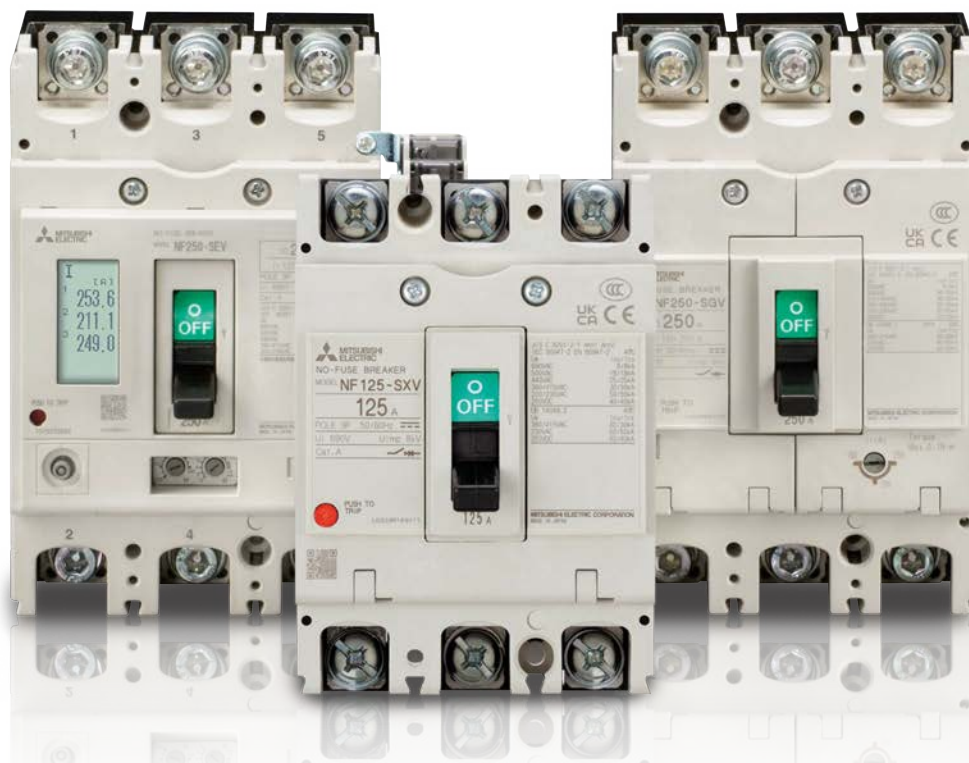

World Super  
**WS-V** Series

Molded Case Circuit Breakers and Earth Leakage Circuit Breakers



Mitsubishi Electric Corporation operates across a wide range of sectors, from home appliances and building systems to railway solutions, factory automation equipment, and satellites and leverages the synergy created by these diverse sectors to address various challenges and provide optimal solutions worldwide.

We, the Mitsubishi Electric Group, will continue to evolve in "carbon neutrality" and a "circular economy" by promoting innovation in products and services and providing integrated solutions through our business activities, all in order to realize a vibrant and sustainable society.

Under "Changes for the Better" which reflects the Mitsubishi Electric Group's commitment to "always strive to achieve something better", Mitsubishi Electric FA will expand the value of its products and services in the FA system business by advancing the provision and expansion of integrated solutions under the slogan "Automating the World" for an even better tomorrow. Through automation technology, we aim to contribute to innovation not only in the manufacturing industry but also across society as a whole.

We stand as your partner in shaping a smarter, more efficient, and more sustainable future.



The Mitsubishi Electric Group is actively solving social issues, such as decarbonization and labor shortages, by providing production sites with energy-saving equipment and solutions that utilize automation systems, thereby helping towards a sustainable society.

# INDEX

<b>Introduction and Features of WS-V Series .....</b>	<b>4</b>	
<b>1. Outline of Circuit Breakers .....</b>	<b>10</b>	<b>1</b>
1) Product Line-up .....	10	
2) Instructions for Application .....	12	
3) Mitsubishi MCCB Manufacturing History .....	14	
4) Mitsubishi ELCB and ELR Manufacturing History .....	15	
<b>2. Detailed Specifications .....</b>	<b>17</b>	
<b>1) Molded Case Circuit Breakers.....</b>	<b>18</b>	
1) NF-C (Economy class) .....	18	
2) NF-S (Standard class).....	20	
3) NF-L/NF-H/NF-R (High-performance class).....	24	
4) NF-U (Ultra current-limiting class).....	27	
<b>2) Earth Leakage Circuit Breakers .....</b>	<b>28</b>	
1) NV-C (Economy class).....	28	
2) NV-S (Standard class).....	30	
3) NV-H/NV-R (High-performance class) .....	32	
<b>3) Motor Protection Breakers.....</b>	<b>34</b>	
1) NF-MB .....	34	
<b>4) UL Certified Circuit Breakers.....</b>	<b>35</b>	
1) UL 489 Listed Molded Case Circuit Breakers .....	35	
2) UL 489 Listed Earth Leakage Circuit Breakers .....	38	
3) UL 1077 Recognized Circuit Breakers for Control boards .....	40	
<b>5) Measuring Display Unit Breakers.....</b>	<b>41</b>	
1) MDU Breakers.....	41	
<b>6) DC High-Voltage Circuit Breakers.....</b>	<b>47</b>	<b>2</b>
<b>7) Miniature Circuit Breakers .....</b>	<b>49</b>	
1) BH .....	49	
2) BV.....	50	
<b>8) Circuit Protectors .....</b>	<b>53</b>	
1) CP .....	53	
<b>9) Low Voltage Air Circuit Breakers .....</b>	<b>56</b>	<b>3</b>
1) Low Voltage Air Circuit Breakers (AE-SW Series) .....	56	
<b>10) Earth Leakage Relays.....</b>	<b>58</b>	
1) Earth Leakage Relays .....	58	
<b>3. Special-purpose Breakers .....</b>	<b>61</b>	<b>4</b>
1) Mag Only (Instantaneous Tripping Circuit Breakers).....	62	
2) DC MCCBs and DSN Switches .....	63	
3) 400Hz MCCBs.....	63	
4) MCCB and ELCB for special environment .....	64	
<b>4. Selection .....</b>	<b>65</b>	
<b>1) Construction and Operation.....</b>	<b>66</b>	
1) Construction of MCCB.....	66	
2) Construction of ELCB.....	68	
<b>2) Selection of MCCB and ELCB .....</b>	<b>69</b>	
1) Selecting Procedure .....	69	
2) Features and Performance.....	70	
3) Current-carrying Capacity and Operating Temperature .....	72	
4) Application of Circuit Breaker According to Breaking Capacity .....	74	
5) Selection of Circuit Breaker for Electric Lamp or Heater Circuit .....	75	
6) Selection of Circuit Breaker for Motor Branch Circuit.....	77	
7) Selection of Motor Protection Breaker.....	79	
8) Selection of Circuit Breaker for Inverter Circuit .....	80	
9) Selection of Circuit Breaker for Transformer Primary Side .....	81	
10) Combination for Selective Breaking .....	85	
11) Combinations for Cascade Breaking.....	87	
12) International Standard Conformance List.....	89	
<b>3) Selection of ELCB.....</b>	<b>92</b>	<b>5</b>
1) Electric Shock Protection .....	92	
2) ELCB Grounding Method .....	93	
3) Rated Voltage and Number of Poles.....	94	
4) Earth Fault Protection Coordination and Combination of Devices .....	95	
<b>5. Installation and Connection .....</b>	<b>97</b>	
1) Connection Types.....	98	
2) Connecting Parts.....	100	
3) Standard Tightening Torque .....	101	
4) Crimp Terminal Type .....	102	
5) Busbar .....	104	
6) Insulation Distance on Power Source Side.....	105	
7) Effect of Installation Orientation .....	106	
8) Connection of Line and Load .....	106	
<b>6. Accessories.....</b>	<b>107</b>	<b>7</b>
<b>1) Internal Accessories.....</b>	<b>108</b>	
1) Internal Accessories .....	108	
2) Terminal Symbols .....	109	
3) Operations and Ratings of Switches .....	109	
4) Maximum Number of Internal Accessories .....	110	
5) Cassette Type Accessories .....	115	
6) Shunt Trip (SHT) .....	117	
7) Undervoltage Trip (UVT) .....	118	
8) Lead Wire Drawing .....	120	
9) Lead Wire Terminal Block .....	120	
10) Test Button Module (TBM) .....	121	
11) Pre-Alarm Module (PAL) .....	122	
<b>2) External Accessories .....</b>	<b>123</b>	<b>8</b>
1) F-type Operating Handle (Breaker Mount Type) .....	123	
2) V-type Operating Handle (Door Mount Type).....	125	
3) C-type Operating Handle.....	127	
4) Terminal Covers .....	128	
5) Insulating Barriers .....	131	
6) Handle Lock Devices, Lock Covers, Auxiliary Handles, Card Holders .....	134	
7) Mechanical Interlocks (MI) .....	136	
8) Boxes for Circuit Breakers and Boxed Circuit Breakers.....	137	
9) Electrical Operated Circuit Breakers and Electrical Operation Devices .....	140	
10) IEC 35mm Rail Mounting Adapters .....	143	

**7. Characteristics and Dimensions ..... 145**

**1 1 Molded Case Circuit Breakers ..... 146**

• NF32-SV, NF63-CV/SV/HV ..... 146  
• NF125-CV/SV/HV ..... 148  
• NF125-UV ..... 150  
• NF250-CV/SV/HV ..... 152  
• NF250-UV ..... 154  
• NF125-SGV/LGV/HGV/RGV, NF160-SGV/LGV/HGV,  
NF250-SGV/LGV/HGV/RGV ..... 156  
• NF125-SEV/HEV, NF250-SEV/HEV ..... 158  
• NF400-CW/SW ..... 160  
• NF400-SEW/HEW/REW ..... 162  
• NF400-UEW ..... 164  
• NF630-CW/SW ..... 166  
• NF630-SEW/HEW/REW ..... 168  
• NF800-CEW/SEW/HEW/REW ..... 170  
• NF800-SDW ..... 172  
• NF800-UEW ..... 174  
• NF1000-SEW, NF1250-SEW ..... 176  
• NF1250-SDW ..... 178  
• NF1600-SEW ..... 180  
• NF1600-SDW ..... 182

**2 2 Earth Leakage Circuit Breakers ..... 184**

• NV32-SV, NV63CV/SV/HV ..... 184  
• NV125-CV/SV/HV ..... 186  
• NV250-CV/SV/HV ..... 188  
• NV125-SEV/HEV, NV250-SEV/HEV ..... 190  
• NV400-CW/SW ..... 192  
• NV400-SEW/HEW ..... 194  
• NV630-CW/SW ..... 196  
• NV630-SEW/HEW ..... 198  
• NV800-SEW/HEW ..... 200

**3 3 UL Certified Circuit Breakers ..... 202**

• NF50-SMU ..... 202  
• NF50-SVFU, NV50-SVFU ..... 204  
• NF100-CVFU, NV100-CVFU ..... 206  
• NF100-SRU/HRU, NV100-SRU/HRU ..... 208  
• NF125-SVU/HVU, NV125-SVU/HVU ..... 210  
• NF250-CVU/SVU/HVU, NV250-CVU/SVU/HVU ..... 212  
• NF400-SWU/HWU ..... 214  
• NF630-SWU/HWU ..... 216  
• NF30-FAU, NF50-FAU, NV30-FAU, NV50-FAU ..... 218  
• NF50-FHU, NF100-FHU, NV50-FHU, NV100-FHU ..... 220

**4 4 Measuring Display Unit Breakers ..... 222**

• NF250-SEV/HEV with MDU ..... 222  
• NF400-SEW/HEW with MDU ..... 224  
• NF800-SEW/HEW with MDU ..... 226

**5 5 DC High-Voltage Circuit Breakers ..... 230**

• NF63-HDV ..... 230  
• NF125-HDVA, NF250-HDVA ..... 232  
• NF400-HDW, NF800-HDW ..... 234

**6 6 Miniature Circuit Breakers,  
Residual Current Circuit Breakers,  
Residual Current Circuit Breakers  
with Overcurrent Protection and  
Isolating Switches ..... 236**

• BH-D6, BH-D10 ..... 236  
• BH-DN ..... 237  
• BV-D ..... 238  
• BV-DN, BV-DN6 ..... 239  
• KB-D ..... 240

**7 7 Circuit Protectors ..... 241**

• CP30-BA/HU ..... 241

**8 8 Electrical Operated Circuit Breakers ..... 242**

**8. Handling and Maintenance ..... 247**

1) Storage and Transportation ..... 248  
2) Normal Service Conditions ..... 248  
3) Mounting and Connections ..... 249  
4) Maintenance and Inspections ..... 252  
5) Troubleshooting ..... 254

**9. Appendix ..... 257**

1) Handle Operation Angle Dimensions ..... 258  
2) MCCB Trip Button, Instantaneous Adjustment Dial Drilling and Terminal Cover Mounting Hole Dimensions ..... 259  
3) ELCB Button and Switch Dimensions ..... 260  
4) List of Product Weights ..... 261  
5) Switching the Adjustable Items ..... 262  
6) Breaker Mounting Screw Dimensions ..... 265  
7) List of Mold Surface Temperature-rise Values ..... 266  
8) Ordering Information ..... 267  
9) Index ..... 269  
10) MELSELECT™ ..... 270  
11) Low-Voltage Products Website ..... 271  
12) Service Network ..... 272



# High-Performance



## Technologies based on long year experience are brought together to realize more improved performance

- The new circuit breaking technology “Expanded ISTAC” has improved the current-limiting performance and upgraded the overall breaking capacity. Expansion of the conductor under the stator shortens the contact parting time of the mover as compared to the conventional ISTAC structure. The current-limiting performance has been improved remarkably. (The maximum peak current value has been reduced by approx. 10%.)

Breaking capacity has been improved with this new technology and, in the case of class S, Icu is now equivalent to Ics.

### Example of breaking capacity improvement

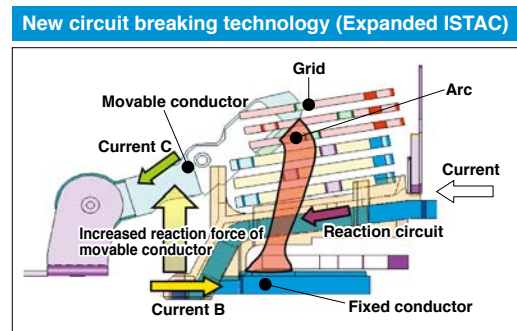
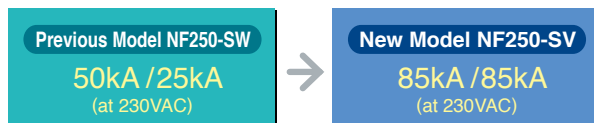

## Breaking capacity of 5 models is 20% to 50% higher than the W & WS Series

- Improvement of breaking capacity on 250AF-C/S/H models (Fixed) and 125AF/250AF-R models (Thermal/Adjustable).

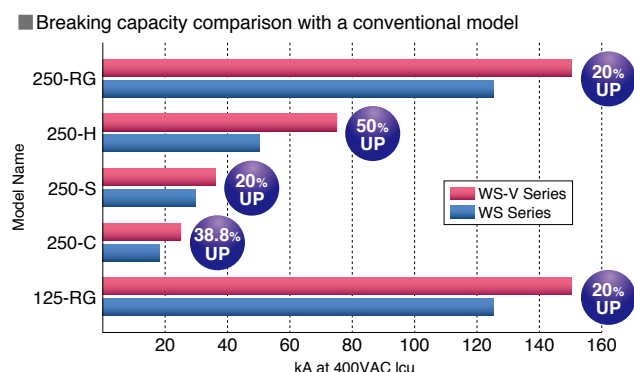



## The new electronic circuit breakers (with display) and MDU breakers can display various measurement items

■ This will enable energy management through “visualization”, which leads to energy saving.



Electronic Circuit Breaker (with display)

Measuring Display Unit Breaker

- The display is on the circuit breaker body and shows circuit information.
- Detailed setting can be done on the display.
- The display turns red during alarms.

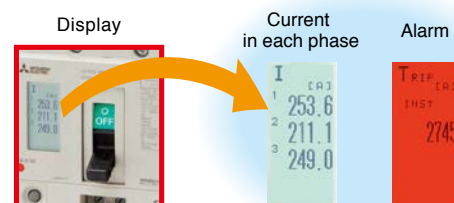

## Intelligent Communications through CC-Link

■ Measuring data can be transmitted to Personal Computer through CC-Link.

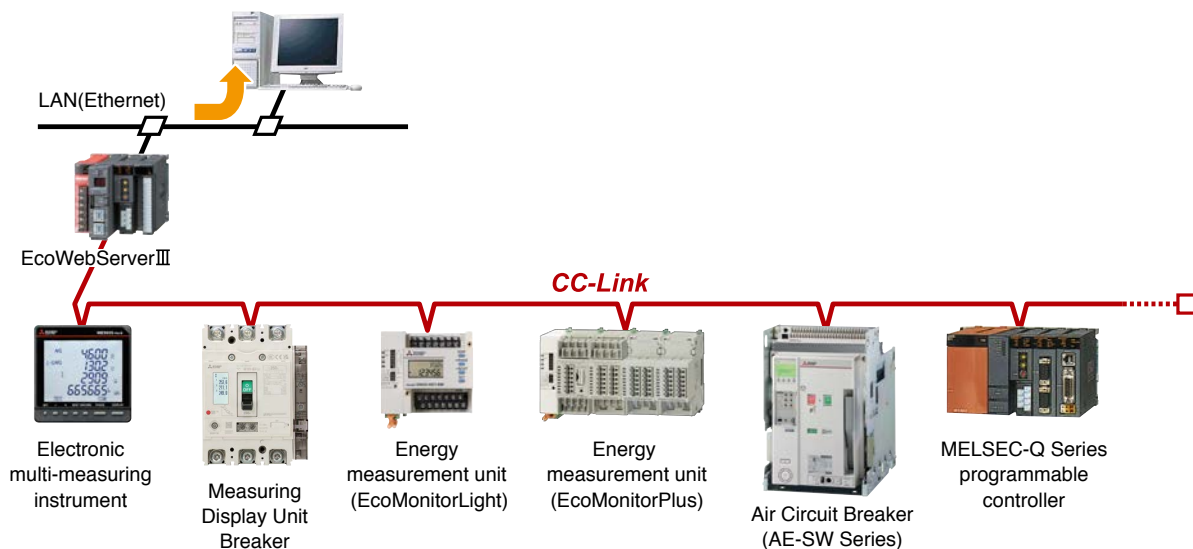

# Standardizaion



## Compact design for easy to use

- The thermal adjustable circuit breakers and electronic circuit breakers are smaller.

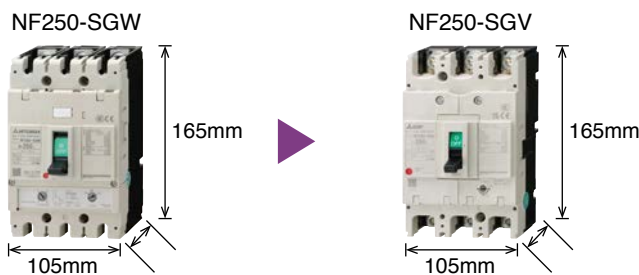

(Conventional model : 105 × 165 × **86mm**) (New model : 105 × 165 × **68mm**)

**Volume ratio 79%**  
(Compared with our conventional models)

- 250AF circuit breakers' fixed types (NF250-CV, NF250-SV, NF250-HV, NV250-CV, NV250-SV, NV250-HV), thermal adjustable types (NF250-SGV, NF250-HGV, NF250-RGV), and electronic types (NF250-SEV, NF250-HEV, NV250-SEV, NV250-HEV) are the same size, leading to the reduction and standardization of panel design.

## Types of internal accessories are reduced from 3 types to 1 type

- Standardization of internal accessories contributes to the reduction of stock and delivery time.

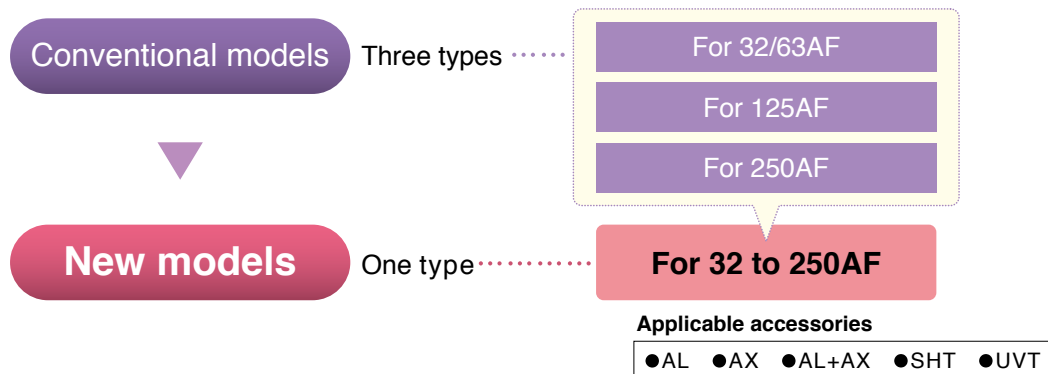

- 32AF and 63AF circuit breakers can now be used in both AC and DC circuits without specifying when ordering. This will lead to prevention of ordering mistakes.

- The earth leakage circuit breakers can now be equipped with a voltage shunt trip device (SHT).

# High Quality



## Innovative manufacturing using a robot-cell production line

- This manufacturing innovation takes the pursuit of increased productivity, shortened manufacturing lead-time and improved quality to the upper limits.



Robot-cell Production Line

## Individual unit production management system

- A multi-model, single-unit flow production system is utilized the ultimate multi-cycle production method. The production line is controlled using barcodes to manage the model information for each unit. Small-lot, flexible production that's one step ahead!

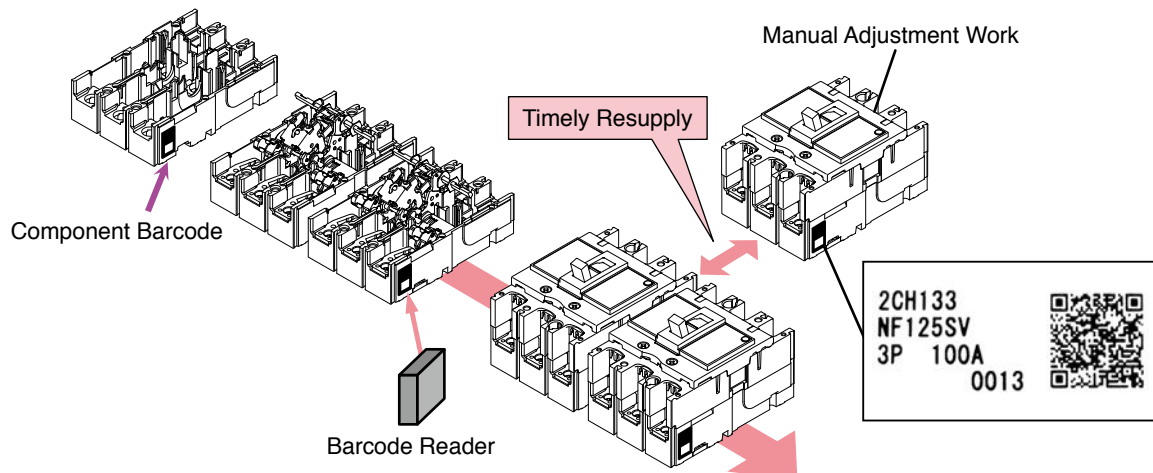

## Use of Various Recyclable Materials

- The circuit breakers are made of thermo-plastic materials that are easy to recycle. (Some models are partially made of thermoset materials.)  
The major plastic parts bear material identifications so that they can be recycled.

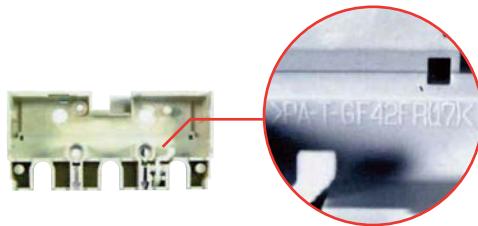

## Nonuse of Hazardous Substances

- Eco-friendly design is used for all circuit breakers, and they do not use hazardous substances. The circuit breakers comply with RoHS regulation.

## Energy Saving at Mitsubishi Electric Corporation Fukuyama Works

- Mitsubishi Electric Corporation Fukuyama Works uses energy saving support devices such as MDU breakers and EcoServer to save energy through “visualization” of energy. Along with “visualization”, Fukuyama Works also installed high-efficiency equipments to further promote energy saving.  
Through energy saving activity, Fukuyama Works has successfully reduced its CO<sub>2</sub> emissions by 38.7%.  
(compared with 2013, results for 2020)



## Global Networks of Sales Offices and Production Bases

■ Our sales networks are designed to comfort customers internationally through the worldwide distributors. Constantly contactable distributors enable us to accommodate customer's needs for smooth supply.

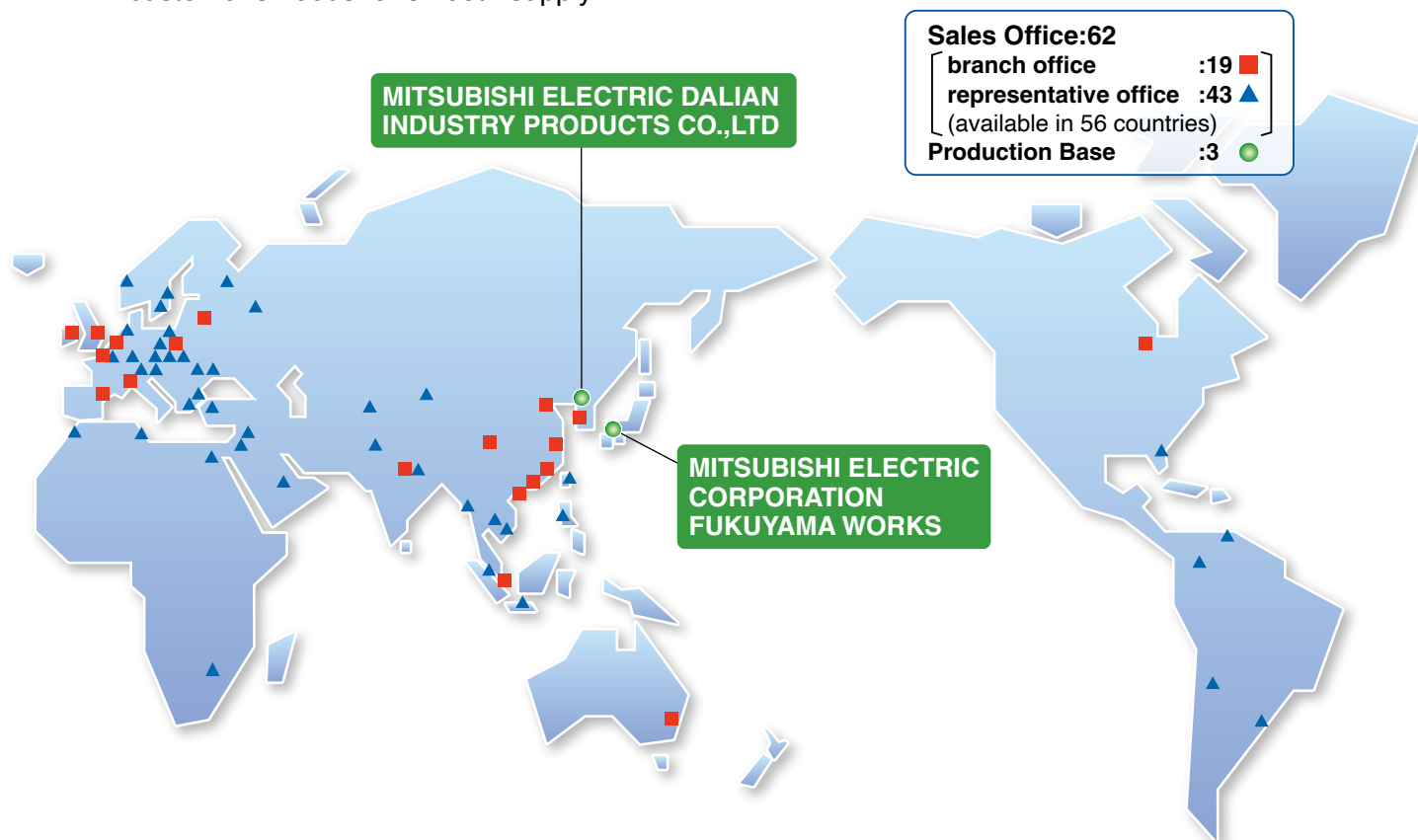

# 1 Outline of Circuit Breakers

## Product Line-up







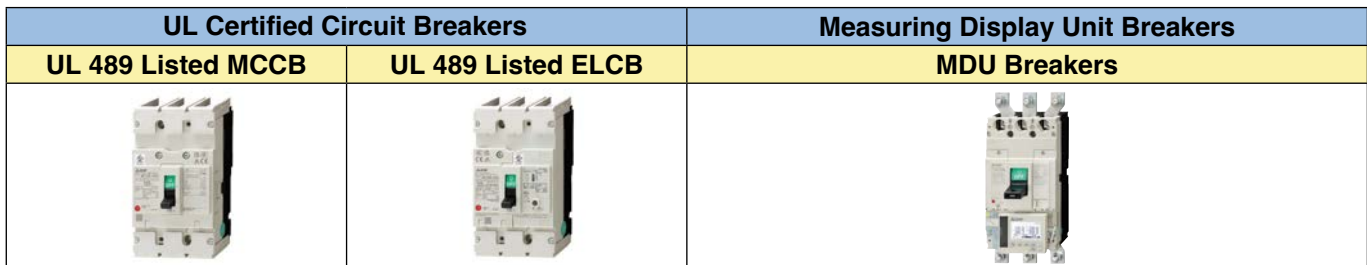
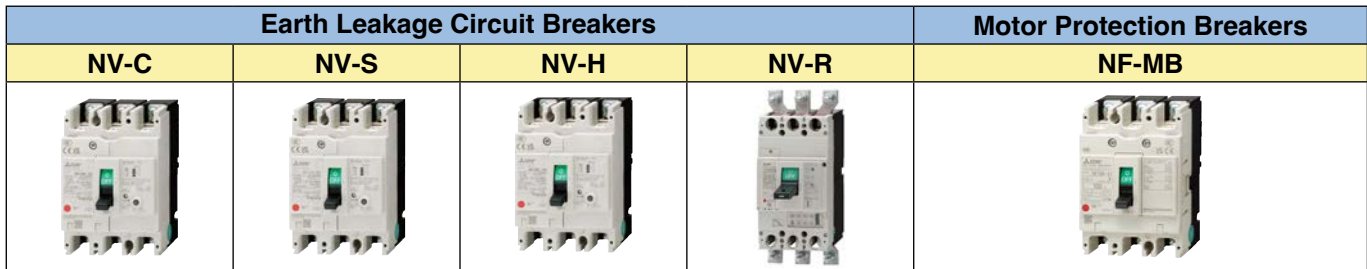
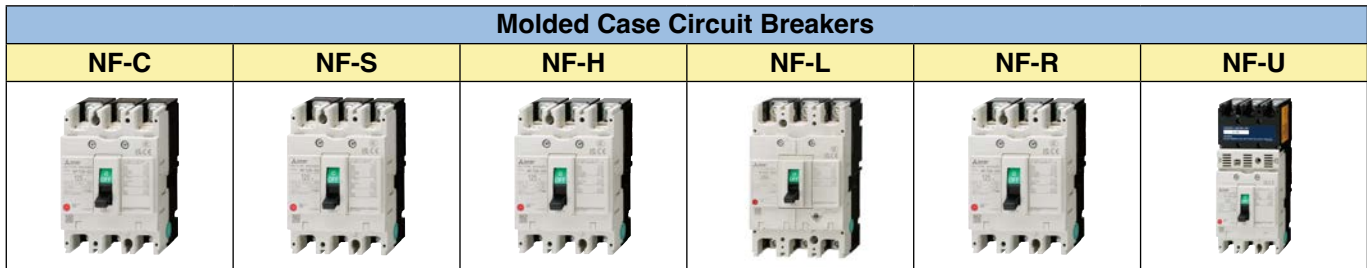

Outline of Circuit Breakers

Classification		Frame (A)	30 32	50 60 63	100 125	160
Molded Case Circuit Breakers	NF-C Economy class			NF63-CV	NF125-CV	
	NF-S Standard class	NF32-SV		NF63-SV	NF125-SV NF125-SGV NF125-SEV	NF160-SGV
	NF-H/L High-performance class			NF63-HV	NF125-HV NF125-LGV NF125-HEV NF125-HGV	NF160-LGV NF160-HGV
	NF-R/U Ultra current-limiting class				NF125-RGV NF125-UV	
Earth Leakage Circuit Breakers	NV-C Economy class			NV63-CV	NV125-CV	
	NV-S Standard class	NV32-SV		NV63-SV	NV125-SV NV125-SEV	
	NV-H/R High-performance class			NV63-HV	NV125-HV NV125-HEV	
Motor Protection Breakers	NF-MB	NF32-SV (*1)	NF63-CV (*1) NF63-SV (*1)	NF125-SV (*1)		
UL Certified Circuit Breakers	UL 489 Listed MCCB			NF50-SVFU NF50-SMU	NF100-CVFU NF100-SRU NF125-SVU NF100-HRU NF125-HVU	
	UL 489 Listed ELCB			NV50-SVFU	NV100-CVFU NV100-SRU NV125-SVU NV100-HRU NV125-HVU	
	UL 1077 Recognized Circuit Breakers for Control boards	NF30-FAU NV30-FAU		NF50-FAU NF50-FHU NV50-FAU NV50-FHU	NF100-FHU NV100-FHU	
Measuring Display Unit Breakers	MDU Breakers					
DC high voltage	NF-HDV			NF63-HDV		
	NF-HDVA				NF125-HDVA	
	NF-HDW					
Miniature Circuit Breakers		BH-DN		BH-D6 BH-D10		
Residual Current Circuit Breaker				BV-D		
Residual Current Circuit Breaker with Overload Protection				BV-DN BV-DN6		
Isolating Switch				KB-D		
Circuit Protectors		CP30-BA CP30-HU				
Air Circuit Breakers	AE-SW					
Related Components	Earth Leakage Relays	NV-ZBA, NV-ZSA, NV-ZHA, NV-ZLA				

Note \*1 When placing an order, specify "MB".  
 WS-V Series



	250	400	600 630	800	1000	1250	1600	2000	2500	3200	4000	5000	6300
	NF250-CV	NF400-CW	NF630-CW	NF800-CEW									
	NF250-SV NF250-SEV	NF250-SGV NF400-SW NF400-SEW	NF630-SW NF630-SEW	NF800-SDW NF800-SEW	NF1000-SEW	NF1250-SDW NF1250-SEW	NF1600-SDW NF1600-SEW						
	NF250-HV NF250-HEV	NF250-LGV NF250-HGV NF400-HEW	NF630-HEW	NF800-HEW									
	NF250-RGV NF250-UV	NF400-REW NF400-UEW	NF630-REW	NF800-REW NF800-UEW									
	NV250-CV	NV400-CW	NV630-CW										
	NV250-SV NV250-SEV	NV400-SW NV400-SEW	NV630-SW NV630-SEW	NV800-SEW									
	NV250-HV NV250-HEV	NV400-HEW	NV630-HEW	NV800-HEW									
	NF250-SV (*1)												
	NF250-CVU NF250-SVU NF250-HVU	NF400-SWU NF400-HWU	NF630-SWU NF630-HWU										
	NV250-CVU NV250-SVU NV250-HVU												
	NF250-SEV with MDU NF250-HEV with MDU	NF400-SEW with MDU NF400-HEW with MDU		NF800-SEW with MDU NF800-HEW with MDU									
	NF250-HDVA												
		NF400-HDW		NF800-HDW									
			AE630-SW		AE1000-SW	AE1250-SW	AE1600-SW	AE2000-SW AE2000-SWA	AE2500-SW	AE3200-SW	AE4000-SWA AE4000-SW	AE5000-SW	AE6300-SW

Miniature Circuit Breakers		
BH-D6	BH-D10	BH-DN
		
Residual Current Circuit Breaker	Residual Current Circuit Breaker with Overload Protection	Isolating Switch
BV-D	BV-DN, BV-DN6	KB-D
		
Circuit Protectors	Air Circuit Breakers	Related Components
CP30-BA	AE-SW	Earth Leakage Relays
		

# Instructions for Application

## 1. Warranty period and warranty coverage

If any faults or defects (hereinafter “Failure”) found to be the responsibility of Mitsubishi Electric occurs during use of the product within the warranty period, the product shall be repaired at no cost via the sales representative or Mitsubishi Electric Sales office. However, if repairs are required on-site at domestic or overseas locations, expenses to send an engineer will be charged.

### 1. Warranty period

The warranty period of the product shall be for twelve (12) months after the date of purchase or delivery to the designated place.

### 2. Warranty coverage

- (1) The primary failure diagnosis should be performed by users. However, if required by users, Mitsubishi Electric or Mitsubishi Electric Sales office may be able to perform the diagnosis. In that case, for damages caused by any cause found to be the responsibility of Mitsubishi Electric, the diagnosis will be performed at no cost. For details, contact a distributor.
- (2) The coverage shall be limited to ordinary use within the usage state, usage methods, usage environment, and other conditions which follow the instructions and precautions given in the instruction manual, user’s manual, and caution labels on the product.
- (3) Even within the warranty period, repair cost shall be charged for the following cases.
  - ① Failure occurring from inappropriate storage or handling, carelessness or negligence by the user. Failure caused by selection of hardware or software design on the user side.
  - ② Failure caused by modifications, etc. to the product by the user without any approvals from Mitsubishi Electric.
  - ③ In case Mitsubishi Electric product is assembled into a user’s device, failure that could have been avoided if functions or structures, judged as necessary in the legal safety measures the user’s device is subject to or as necessary by industry standards, had been provided.
  - ④ Failure that could have been avoided if the maintenance described in the user’s manual has been performed.
  - ⑤ Failure caused by external irresistible forces such as fires or abnormal voltages, and failure caused by natural disasters such as earthquakes, lightning, wind and water damages.
  - ⑥ Failure caused by reasons unpredictable based on scientific technology standards at the time of shipment from Mitsubishi Electric.
  - ⑦ Any other failure found not to be the responsibility of Mitsubishi Electric or that admitted not to be so by the user.

In addition, the warranty applies only to the product delivered. It does not apply to the damage that is caused by the failure of the product.

## 3. The period to supply the spare parts after discontinuation of production

Mitsubishi Electric shall supply spare parts for five (5) years after discontinuation of production. After five years, Mitsubishi Electric shall supply spare parts until the spare parts run out of stock.

## 2. Exclusion of loss in opportunity and secondary loss from warranty liability

Regardless of the warranty period, Mitsubishi Electric shall not be liable for compensation to:

- (1) Damages caused by any cause found not to be the responsibility of Mitsubishi Electric.
- (2) Loss in opportunity, lost profits incurred to the user by failures of Mitsubishi Electric product.
- (3) Damages whether foreseeable or not, secondary damages, compensation for accidents, and compensation for damages to products other than Mitsubishi Electric products, caused by exceptional situations.
- (4) Compensation for cost occurring secondarily from replacement work by the user, maintenance of on-site equipment and start-up test run and other operations.
- (5) Regarding the usage which is out of the scope of handling that is described in the catalogue, we cannot guarantee the performance of our circuit breakers at all.

## 3. Product applications

- (1) When using the products listed in this catalogue, the following conditions must be confirmed and obeyed. The product must be used so that a failure that occurs to the product does not lead to a serious accident. When a damage or failure occurs, the external backup function or fail-safe function must be executed systematically.
- (2) The products listed in this catalogue are designed and manufactured as general-purpose products for application to the general industry field. Therefore, the warranty does not apply to the following special uses.

- ① The use that has a significant influence on the public facilities such as nuclear power plants and other power plants of power companies.
- ② The use for railway companies, government offices, etc. that require to build the special quality assurance system.
- ③ The use for aerospace equipment, medical equipment, railway equipment, combustion and fuel equipment, passenger vehicles, manned transportation equipment, recreational equipment, safety equipment, and air conditioner for servers and the cooling facilities that are expected to have a significant influence on life, body, and property.

If the products listed in this catalogue are used for the above mentioned special uses, Mitsubishi Electric does not take any responsibility for the quality, performance, and safety of the product, which includes, but is not limited to, default liability, defect liability, quality assurance liability, tort liability, and product liability. However, in case

the special quality (beyond general specifications) is not required and the use is a limited purpose and the backup/fail-safe functions are equipped with the facility, Mitsubishi Electric may determine that the products listed in this catalogue can be guaranteed. For details, consult a distributor or Mitsubishi Electric.

## 4. Safety precautions

- Carefully read the safety precautions prior to use the circuit breaker correctly.
- Important safety instructions are given below. Strictly observe the instructions.
- Be sure to communicate these safety precautions to the end user.

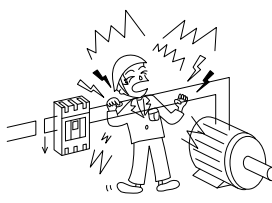
<b>⚠ DANGER</b>
<ul style="list-style-type: none"> <li>● Do not touch the terminal area. Doing so can cause an electric shock.</li> <li>● The earth leakage circuit breakers are designed to operate when the difference between leaving current and returning current exceeds the specified value. In the case shown in this figure, earth leakage is not detected. Therefore, never touch the two bare live parts. The circuit breaker will not operate upon occurrence of an electric shock.</li> </ul>
 <p style="text-align: center;">Earth leakage circuit breaker</p>

### Instructions for installation

<b>⚠ CAUTION</b>
<ul style="list-style-type: none"> <li>● The electrical work shall be performed by qualified personnel (electrical workers).</li> <li>● Before performing wiring work, turn off the upstream circuit breaker, and ensure that no current is flowing through the circuit breaker to be wired. Failure to do so may expose you to shock hazard.</li> <li>● When connecting any wire, tighten the terminal screw to the torque specified in the instruction manual. Failure to do so may cause a fire.</li> <li>● When the model comes with insulating barriers as standard accessories, install the insulating barriers without fail.</li> <li>● Do not install the circuit breaker in an abnormal environment with high temperature, high moisture, dust, corrosive gas, vibration or shock. Doing so may cause a fire or make the circuit breaker inoperative.</li> <li>● Protect the circuit breaker so that foreign particles, such as dust, concrete powder and iron powder, and rain water will not enter the circuit breaker. Failure to do so may make the circuit breaker inoperative.</li> </ul> <p>[Earth leakage circuit breaker]</p> <ul style="list-style-type: none"> <li>● When using an earth leakage circuit breaker for use only in single-phase 3-wire or 3-phase 4-wire systems, connect the neutral wire to the neutral phase without fail. If they are not connected, the circuit breaker may not operate in the case of open phase or overcurrent, thereby resulting in a fire.</li> <li>● Connect the circuit breaker to a power supply appropriate to the rating of its body. Failure to do so may make the circuit breaker inoperative or damage it.</li> <li>● Tighten securely the lead wire in the open phase to the neutral wire on the load side. If the wires are not connected, the open phase of the neutral wire cannot be detected.</li> <li>● When there are two terminal screws for the neutral pole, tighten the screws alternately. Failure to do so may loosen the screws, thereby causing a fire.</li> </ul>

### [Explanation of warning symbols]

<b>⚠ DANGER</b>	Incorrect handling of the product will result in a hazardous situation, such as death or serious injury.
<b>⚠ CAUTION</b>	Incorrect handling of the product may result in a hazardous situation according to circumstances.
⊘	This means something is prohibited and should never be performed.
⚠	Ignition or fire may occur under certain circumstances.

### Instructions for use

<b>⚠ CAUTION</b>
<ul style="list-style-type: none"> <li>● When the circuit breaker automatically breaks a circuit, turn on the handle after removing the cause. Failure to do so may cause an electric shock or a fire.</li> </ul> <p>[Earth leakage circuit breaker]</p> <ul style="list-style-type: none"> <li>● Ground the earth terminal of electrical equipment. Failure to do so may cause an electric shock or a fire.</li> <li>● Press the test button to check the operation once a month or so. If the earth leakage circuit breaker is not turned off, it is out of order. Consult an electrician.</li> </ul>

### Instructions for maintenance

<b>⚠ CAUTION</b>
<ul style="list-style-type: none"> <li>● The circuit breakers shall be maintained by persons with specialized knowledge.</li> <li>● Before maintaining, turn off the upstream circuit breaker, and ensure that no current is flowing through the circuit breaker to be maintained. Failure to do so may expose you to shock hazard.</li> <li>● Retighten the terminals periodically. Failure to do so may cause a fire.</li> </ul>

### Instructions for disposal

<b>⚠ CAUTION</b>
<ul style="list-style-type: none"> <li>● When disposing of the product, treat it as industrial waste.</li> </ul>

## 5. Change in product specifications

The specifications of the product listed in this catalogue, manuals or technical documents are subject to change without prior notice.









# 2

## Detailed Specifications

<b>1 Molded Case Circuit Breakers</b>	<b>18</b>
1) NF-C (Economy class).....	18
2) NF-S (Standard class).....	20
3) NF-L/NF-H/NF-R (High-performance class).....	24
4) NF-U (Ultra current-limiting class).....	27
<b>2 Earth Leakage Circuit Breakers</b>	<b>28</b>
1) NV-C (Economy class).....	28
2) NV-S (Standard class).....	30
3) NV-H/NV-R (High-performance class).....	32
<b>3 Motor Protection Breakers</b>	<b>34</b>
1) NF-MB.....	34
<b>4 UL Certified Circuit Breakers</b>	<b>35</b>
1) UL 489 Listed Molded Case Circuit Breakers.....	35
2) UL 489 Listed Earth Leakage Circuit Breakers.....	38
3) UL 1077 Recognized Circuit Breakers for Control boards.....	40
<b>5 Measuring Display Unit Breakers</b>	<b>41</b>
1) MDU Breakers.....	41
<b>6 DC High-Voltage Circuit Breakers</b>	<b>47</b>
<b>7 Miniature Circuit Breakers</b>	<b>49</b>
1) BH.....	49
2) BV.....	50
<b>8 Circuit Protectors</b>	<b>53</b>
1) CP.....	53
<b>9 Low Voltage Air Circuit Breakers</b>	<b>56</b>
1) Low Voltage Air Circuit Breakers (AE-SW Series).....	56
<b>10 Earth Leakage Relays</b>	<b>58</b>
1) Earth Leakage Relays.....	58



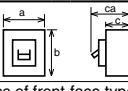

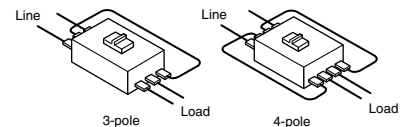

## NF-C (Economy class)

Frame (A)		50	60	63	100	125		
Model		NF63-CV			NF125-CV			
Image								
Rated current In (A)		3 4 (5) 6 10 (15) 16 20 25	(60)	63	50 (60) 63 (75) 80 100	125		
Reference ambient temperature 40°C (45°C for marine use)								
Number of poles		2 3	2 3	2 3	2 3	2 3		
Rated insulation voltage Ui (V)		600	600	600	600	600		
Relative short-circuit breaking capacities (kA)	IEC 60947-2 EN 60947-2 (Icu/Ics)	AC	690V	-	-	-	-	
			500V	2.5/2.5	2.5/2.5	2.5/2.5	7.5/4	7.5/4
			440V	2.5/2.5	2.5/2.5	2.5/2.5	10/5	10/5
			415V	2.5/2.5	2.5/2.5	2.5/2.5	10/5	10/5
			400V	5/5	5/5	5/5	10/5	10/5
			380V	5/5	5/5	5/5	10/5	10/5
			230V	7.5/7.5	7.5/7.5	7.5/7.5	30/15	30/15
			200V	7.5/7.5	7.5/7.5	7.5/7.5	30/15	30/15
			DC	250V	2.5/2.5 (*5)	2.5/2.5 (*5)	2.5/2.5 (*5)	7.5/4 (*3)
Rated impulse withstand voltage Uimp (kV)		8	8	8	8	8		
Current (*1)		AC/DC compatible	AC/DC compatible	AC/DC compatible	AC/DC compatible	AC/DC compatible		
Suitability for isolation		Yes	Yes	Yes	Yes	Yes		
Reverse connection		Available	Available	Available	Available	Available		
Number of operating cycles	Without current	10,000	10,000	10,000	10,000	10,000		
	With current (440VAC)	6,000	6,000	6,000	6,000	6,000		
Selectivity category		A	A	A	A	A		
Pollution degree		3	3	3	3	3		
EMC environment condition (environment A or B)		Not Applicable	Not Applicable	Not Applicable	Not Applicable	Not Applicable		
Overall dimensions (mm)		a	50 75	50 75	50 75	60 90	60 90	
		b	130	130	130	130	130	
		c	68	68	68	68	68	
		ca	90	90	90	90	90	
Mass of front-face type (kg)		0.45 0.65	0.5 0.7	0.5 0.7	0.6 0.9	0.6 0.9		
Front connection (F) Page		●Screw terminal		●Screw terminal		●Screw terminal		
Installation and connections	Solderless (BOX) terminal (SL)	-		-		●		
	Rear (B)	●Round stud		●Round stud		●Bar stud		
	Plug-in (PM)	●		●		●		
Cassette-type accessories	Alarm switch (AL)	●(*4)		●(*4)		●(*4)		
	Auxiliary switch (AX)	●(*4)		●(*4)		●(*4)		
	Shunt trip (SHT)	●(*4)		●(*4)		●(*4)		
	Undervoltage trip (UVT)	●(*4)		●(*4)		●(*4)		
	With lead-wire terminal block (SLT)	●		●		●		
	Pre-alarm (PAL)	-		-		-		
External accessories	Enclosure	Closed (S)	●		●		●	
		Dustproof (I)	●		●		●	
		Waterproof (W)	-	●	-	●	-	●
	Electrical operation device (NFM)	140	-	-	-	-	●	●
		Mechanical interlock (MI) (*8)	136	●	●	●	●	●
	Lock cover	LC	●	●	●	●	●	
		134	●	●	●	●	●	
	Handle lock device	HL	●	●	●	●	●	
		HL-S	●	●	●	●	●	
	External operating handle	(F)	●	●	●	●	●(*4)	
		(V)	●	●	●	●	●	
Terminal cover (TC-L, TC-S, TTC, BTC, PTC)	128	●	●	●	●	●		
Rear stud (B-ST)	100	●	●	●	●	●		
Plug-in (PM)	143	●	●	●	●	●		
IEC 35mm rail mounting adapters	143	●	●	●	-	-		
CE marking		Self-declaration	Self-declaration	Self-declaration	Self-declaration	Self-declaration		
UKCA marking		Self-declaration	Self-declaration	Self-declaration	Self-declaration	Self-declaration		
CCC		Certified	Certified	Certified	Certified	Certified		
Marine use approval (☆:Certified) (NK, LR, ABS, DNV)		☆	☆	☆	☆	☆		
Automatic tripping device		Thermal-magnetic	Thermal-magnetic	Thermal-magnetic	Thermal-magnetic	Thermal-magnetic		
Trip button		Equipped	Equipped	Equipped	Equipped	Equipped		
Page of Characteristics and dimensions		146			148			

- Notes: \*1 The operating characteristics are different between AC and DC.  
 \*2 For 100A of rated current, NK rating is not shown.  
 \*3 For 3-pole product, connect cables/busbars to any two terminals, and for 4-pole product, connect cables/busbars to any two terminals except N-pole.  
 When connected cables/busbars as shown on the right, maximum of 400VDC can be applied to 3-pole product and maximum of 500VDC to 4-pole product.  
 \*4 This accessory is cassette type and can be installed by customer. The frame size up to 250A can be closely installed, except for those with UVT.  
 \*5 For 3-pole product, connect cables/busbars to any two terminals, and for 4-pole product, connect cables/busbars to any two terminals except N-pole.  
 Not available for use with connection as shown on the right.  
 \*6 Place an order with circuit breaker.  
 \*7 Solid state relay output is available as an option. Specify if this contact output is required. Lead-wire terminal block (SLT) is equipped as standard.  
 \*8 No isolation function except 400A to 800A frame.



**NF-C (Economy class)**

225		250		400		600		630		800	
NF250-CV		NF250-CV		NF400-CW		NF400-CW		NF630-CW		NF800-CEW	
											
(100) 125 150 175 200 225 (*2)		250		250 300 350 400		500 600		(630)		Adjustable 400 450 500 600 700 800	
2 3		2 3		2 3		2 3		2 3		3	
600		600		690		690		690		690	
-		-		-		-		-		-	
10/8		10/8		15/8		18/9		18/9		18/9	
15/12		15/12		25/13		36/18		36/18		36/18	
25/19		25/19		36/18		36/18		36/18		36/18	
25/19		25/19		36/18		36/18		36/18		36/18	
25/19		25/19		40/20		40/20		40/20		40/20	
36/27		36/27		50/25		50/25		50/25		50/25	
36/27		36/27		50/25		50/25		50/25		50/25	
15/12 (*3)		15/12 (*3)		20/10 (*3)		20/10 (*3)		20/10 (*3)		-	
8		8		8		8		8		8	
AC/DC compatible		AC/DC compatible		AC/DC compatible		AC/DC compatible		AC/DC compatible		AC	
Yes		Yes		Yes		Yes		Yes		Yes	
Available		Available		Available		Available		Available		Available	
8,000		8,000		6,000		6,000		6,000		4,000	
4,000		4,000		1,000		1,000		1,000		500	
A		A		A		A		A		B	
3		3		3		3		3		3	
Not Applicable		Not Applicable		Not Applicable		Not Applicable		Not Applicable		A	
105		105		140		140		140		210	
165		165		257		257		257		275	
68		68		103		103		103		103	
92		92		134		155		155		155	
1.3 1.5		1.3 1.5		4.4 5.0		5.2 6.0		5.2 6.0		10.9	
●Screw terminal		●Screw terminal		●Busbar terminal		●Busbar terminal		●Busbar terminal		●Busbar terminal	
●		●		-		-		-		-	
●Bar stud		●Bar stud		●Bar stud		●Bar stud		●Bar stud		●Bar stud	
●		●		●		●		●		●	
●(*4)		●(*4)		●(*4)		●(*4)		●(*4)		●(*4)	
●(*4)		●(*4)		●(*4)		●(*4)		●(*4)		●(*4)	
●(*4)		●(*4)		●(*4)		●(*4)		●(*4)		●(*4)	
●(*4)		●(*4)		●		●		●		●	
-		-		-		-		-		●(*7)	
●		●		-		-		-		-	
-		-		●(*6)		●(*6)		●(*6)		●(*6)	
●		●		●		●		●		●	
●		●		●		●		●		●	
●		●		●		●		●		●	
●		●		●		●		●		●	
●		●		●		●		●		●	
●		●		●		●		●		●	
●		●		●		●		●		●	
●		●		●		●		●		●	
●		●		●		●		●		●	
-		-		●		●		●		●	
-		-		-		-		-		-	
TÜV approval		TÜV approval		Self-declaration		Self-declaration		Self-declaration		Self-declaration	
Self-declaration		Self-declaration		Self-declaration		Self-declaration		Self-declaration		Self-declaration	
Certified		Certified		Certified		Certified		Certified		Certified	
☆(*4)		☆		☆		☆		☆		☆	
Thermal-magnetic		Thermal-magnetic		Thermal-magnetic		Thermal-magnetic		Thermal-magnetic		Electronic (effective value detection)	
Equipped		Equipped		Equipped		Equipped		Equipped		Equipped	
152		152		160		166		166		170	

Remarks: 1. Products with rated current parenthesized are produced when an order is placed.  
 2. Specify "P-LT" when selecting plug-in type with lead-wire terminal block.  
 3. The circuit breaker has the rated short-circuit breaking capacity specified in the shaded cells.  
 4. NF250-CV (100A) does not have any marine use approvals.

## NF-S (Standard class)

Frame (A)		30		32		50			60			63				
Model		NF32-SV						NF63-SV								
Image																
Rated current In (A) Reference ambient temperature 40°C (45°C for marine use)		3 4 (5) 6 10 (15) 16 20 25 (30)		32		3 4 (5) 6 10 (15) 16 20 25 (30) 32 40 50			(60)			63				
Number of poles		2 3		2 3		2 3 4			2 3 4			2 3 4				
Rated insulation voltage Ui (V)		600		600		600			600			600				
Rated short-circuit breaking capacities (kA)	IEC 60947-2 EN 60947-2 (Icu/Ics)	AC	690V	-		-		-			-			-		
			500V	2.5/2.5		2.5/2.5		7.5/7.5			7.5/7.5			7.5/7.5		
			440V	2.5/2.5		2.5/2.5		7.5/7.5			7.5/7.5			7.5/7.5		
			415V	2.5/2.5		2.5/2.5		7.5/7.5			7.5/7.5			7.5/7.5		
			400V	5/5		5/5		7.5/7.5			7.5/7.5			7.5/7.5		
			380V	5/5		5/5		7.5/7.5			7.5/7.5			7.5/7.5		
			230V	7.5/7.5		7.5/7.5		15/15			15/15			15/15		
			200V	7.5/7.5		7.5/7.5		15/15			15/15			15/15		
DC	250V	2.5/2.5 (*5)		2.5/2.5 (*5)		7.5/7.5 (*5)			7.5/7.5 (*5)			7.5/7.5 (*5)				
Rated impulse withstand voltage Uimp (kV)		8		8		8			8			8				
Current (*1)		AC/DC compatible		AC/DC compatible		AC/DC compatible			AC/DC compatible			AC/DC compatible				
Suitability for isolation		Yes		Yes		Yes			Yes			Yes				
Reverse connection		Available		Available		Available			Available			Available				
Number of operating cycles	Without current	10,000		10,000		15,000			15,000			15,000				
	With current (440VAC)	6,000		6,000		8,000			8,000			8,000				
Selectivity category		A		A		A			A			A				
Pollution degree		3		3		3			3			3				
EMC environment condition (environment A or B)		Not Applicable		Not Applicable		Not Applicable			Not Applicable			Not Applicable				
Overall dimensions (mm)		a	50	75	50	75	50	75	100	50	75	100	50	75	100	
		b	130		130		130			130			130			
		c	68		68		68			68			68			
		ca	90		90		90			90			90			
Mass of front-face type (kg)		0.45	0.65	0.45	0.65	0.5	0.7	0.9	0.55	0.75	1.0	0.55	0.75	1.0		
Installation and connections	Front connection (F)	Page	●Screw terminal		●Screw terminal		●Screw terminal			●Screw terminal			●Screw terminal			
	Solderless (BOX) terminal (SL)	98	-		-		-			-			-			
	Rear (B)	98	●Bar stud		●Round stud		●Round stud			●Round stud			●Round stud			
	Plug-in (PM)	98	-		-		-			-			-			
Cassette-type accessories	Alarm switch (AL)	115	●(*4)		●(*4)		●(*4)			●(*4)			●(*4)			
	Auxiliary switch (AX)	115	●(*4)		●(*4)		●(*4)			●(*4)			●(*4)			
	Shunt trip (SHT)	115	●(*4)		●(*4)		●(*4)			●(*4)			●(*4)			
	Undervoltage trip (UVT)	115	●(*4)		●(*4)		●(*4)			●(*4)			●(*4)			
	With lead-wire terminal block (SLT)	120	●		●		●			●			●			
Pre-alarm (PAL)	122	-		-		-			-			-				
External accessories	Enclosure	Closed (S)	●		●		●			●			●			
		Dustproof (I)	●		●		●			●			●			
	Waterproof (W)	IP40	-		-		-			-			-			
		IP54	●		●		●			●			●			
	Electrical operation device (NFM)	Mechanical interlock (MI) (*7)	136	●		●		●			●			●		
		Panel mounting Breaker mounting	136	●		●		●			●			●		
	Lock cover	LC	134	●		●		●			●			●		
		HL	134	●		●		●			●			●		
	Handle lock device	HL-S	123	●		●		●			●			●		
		(F)	123	●		●		●			●			●		
External operating handle (V)	128	●		●		●			●			●				
Terminal cover (TC-L, TC-S, TTC, BTC, PTC)	128	●		●		●			●			●				
Rear stud (B-ST)	100	●		●		●			●			●				
Plug-in (PM)	143	●		●		●			●			●				
IEC 35mm rail mounting adapters	143	●		●		●			●			●				
CE marking		Self-declaration		Self-declaration		Self-declaration			Self-declaration			Self-declaration				
UKCA marking		Self-declaration		Self-declaration		Self-declaration			Self-declaration			Self-declaration				
CCC		Certified		Certified		Certified			Certified			Certified				
Marine use approval (☆:Certified) (NK, LR, ABS, DNV)		☆		☆		☆			☆			☆				
Automatic tripping device		Thermal-magnetic		Thermal-magnetic		Thermal-magnetic			Thermal-magnetic			Thermal-magnetic				
Trip button		Equipped		Equipped		Equipped			Equipped			Equipped				
Page of Characteristics and dimensions		146		146		146			146			146				

- Notes:
- \*1 The operating characteristics are different between AC and DC.
  - \*2 For 100A of rated current, NK rating is not shown.
  - \*3 For 3-pole product, connect cables/busbars to any two terminals, and for 4-pole product, connect cables/busbars to any two terminals except N-pole.  
When connected cables/busbars as shown on the right, maximum of 400VDC can be applied to 3-pole product and maximum of 500VDC to 4-pole product.  
(For NF250-SV model, connected as shown on the right, maximum of 500VDC can be applied to 3-pole product and maximum of 600VDC to 4-pole product.)
  - \*4 This accessory is cassette type and can be installed by customer. The frame size up to 250A can be closely installed, except for those with UVT.
  - \*5 For 3-pole product, connect cables/busbars to any two terminals, and for 4-pole product, connect cables/busbars to any two terminals except N-pole.  
Not available for use with connection as shown on the right.
  - \*6 Place an order with circuit breaker.
  - \*7 No isolation function except 400A to 800A frame.

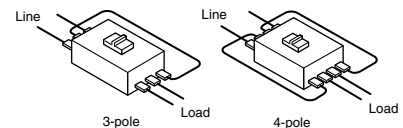









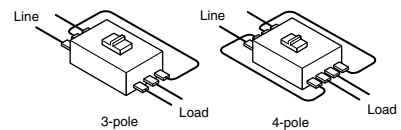

## NF-S (Standard class)

Frame (A)		250			250			400			400			600			630		
Model		NF250-SGV			NF250-SEV			NF400-SW			NF400-SEW			NF630-SW					
Image																			
Rated current In (A) Reference ambient temperature 40°C (45°C for marine use)		125-160 140-200 175-250			Adjustable 80-160 125-250 (8A step) (12.5A step)			250 300 350 400			Adjustable 200 225 250 300 350 400			500 600 (630)					
Number of poles		2	3	4	3	4	2	3	4	3	4	2	3	4	2	3	4		
Rated insulation voltage Ui (V)		690			690			690			690			690					
Rated short-circuit breaking capacities (kA) IEC 60947-2 EN 60947-2 (Icu/Ics)	AC	690V	8/8	8/8	10/10	10/10	10/10	10/10	10/10	10/10	10/10	10/10	10/10	10/10	10/10	10/10	10/10		
		500V	30/30	30/30	30/30	30/30	30/30	30/30	30/30	30/30	30/30	30/30	30/30	30/30	30/30	30/30	30/30		
		440V	36/36	36/36	36/36	42/42	42/42	42/42	42/42	42/42	42/42	42/42	42/42	42/42	42/42	42/42	42/42		
		415V	36/36	36/36	45/45	45/45	45/45	45/45	45/45	45/45	45/45	45/45	45/45	45/45	45/45	45/45	45/45		
		400V	36/36	36/36	45/45	45/45	45/45	45/45	45/45	45/45	45/45	45/45	45/45	45/45	45/45	45/45	45/45		
		380V	36/36	36/36	50/50	50/50	50/50	50/50	50/50	50/50	50/50	50/50	50/50	50/50	50/50	50/50	50/50		
		230V	85/85	85/85	85/85	85/85	85/85	85/85	85/85	85/85	85/85	85/85	85/85	85/85	85/85	85/85	85/85		
		200V	85/85	85/85	85/85	85/85	85/85	85/85	85/85	85/85	85/85	85/85	85/85	85/85	85/85	85/85	85/85		
		DC	250V	20/20 (300V) (*2)	-	40/40 (*2)	-	40/40 (*2)	-	40/40 (*2)	-	40/40 (*2)	-	40/40 (*2)	-	40/40 (*2)	-	40/40 (*2)	
		Rated impulse withstand voltage Uimp (kV)		8			8			8			8			8			
Current		AC/DC compatible			AC			AC/DC compatible			AC			AC/DC compatible					
Suitability for isolation		Yes			Yes			Yes			Yes			Yes					
Reverse connection		Available			Available			Available			Available			Available					
Number of operating cycles	Without current	25,000			25,000			6,000			6,000			6,000					
	With current (440VAC)	10,000			10,000			1,000			1,000			1,000					
Selectivity category		A			A			A			B			A					
Rated short time with stand current Icw (kA) at 0.25s		-			-			-			5			-					
Pollution degree		3			3			3			3			3					
EMC environment condition (environment A or B)		Not Applicable			A			Not Applicable			A			Not Applicable					
Overall dimensions (mm)	a	105	140	105	140	140	185	140	185	140	185	140	185	140	185	140	185		
	b	165	165	165	165	257	257	257	257	257	257	257	257	257	257	257	257		
	c	68	68	68	68	103	103	103	103	103	103	103	103	103	103	103	103		
	ca	92	92	92	92	155	155	155	155	155	155	155	155	155	155	155	155		
Mass of front-face type (kg)		1.4	1.6	2.0	1.7	2.2	4.6	5.2	6.8	6.0	7.6	5.4	6.2	8.0	5.4	6.2	8.0		
Installation and connections	Front connection (F)	●			●Screw terminal			●Screw terminal			●Busbar terminal			●Busbar terminal					
	Solderless (BOX) terminal (SL)	●			●			-			-			-					
	Rear (B)	●Bar stud			●Bar stud			●Bar stud			●Bar stud			●Bar stud					
Plug-in (PM)	●			●			●			●			●						
Cassette-type accessories	Alarm switch (AL)	●(*3)	●	●(*3)	●	●(*3)	●	●(*3)	●	●(*3)	●	●(*3)	●	●(*3)	●	●(*3)	●		
	Auxiliary switch (AX)	●(*3)	●	●(*3)	●	●(*3)	●	●(*3)	●	●(*3)	●	●(*3)	●	●(*3)	●	●(*3)	●		
	Shunt trip (SHT)	●(*3)	●	●(*3)	●	●(*3)	●	●(*3)	●	●(*3)	●	●(*3)	●	●(*3)	●	●(*3)	●		
	Undervoltage trip (UVT)	●(*3)	●	●(*3)	●	●(*3)	●	●(*3)	●	●(*3)	●	●(*3)	●	●(*3)	●	●(*3)	●		
	With lead-wire terminal block (SLT)	●	●	●	●	●	●	●	●	●	●	●	●	●	●	●	●		
Pre-alarm (PAL)	-	-	-	-	-	-	-	-	-	●(*5)	-	-	-	-	-	-			
External accessories	Enclosure	Closed (S)	●	-	●	-	●	-	●	-	●	-	●	-	●	-	●		
		Dustproof (I)	●	-	●	-	●	-	●	-	●	-	●	-	●	-	●		
		Waterproof (W)	●	-	●	-	●	-	●	-	●	-	●	-	●	-	●		
	Electrical operation device (NFM)	Panel mounting	●	●	●	●	●(*6)	●	●(*6)	●	●(*6)	●	●(*6)	●	●(*6)	●	●(*6)		
		Breaker mounting	●	●	●	●	●	●	●	●	●	●	●	●	●	●	●		
	Lock cover	LC	●	●	●	●	-	-	-	-	-	-	-	-	-	-	-		
		HL	●	●	●	●	●	●	●	●	●	●	●	●	●	●	●		
	Handle lock device	HL-S	●	●	●	●	●	●	●	●	●	●	●	●	●	●	●		
		(F)	●	●	●	●	●	●	●	●	●	●	●	●	●	●	●		
	External operating handle (V)	●	●	●	●	●	●	●	●	●	●	●	●	●	●	●	●		
Terminal cover (TC-L, TC-S, TTC, BTC, PTC)	●	●	●	●	●	●	●	●	●	●	●	●	●	●	●	●			
Rear stud (B-ST)	●	●	●	●	●	●	●	●	●	●	●	●	●	●	●	●			
Plug-in (PM)	●	●	●	●	●	●	●	●	●	●	●	●	●	●	●	●			
IEC 35mm rail mounting adapters	●	●	●	●	●	●	●	●	●	●	●	●	●	●	●	●			
CE marking		Self-declaration			Self-declaration			Self-declaration			Self-declaration			Self-declaration					
UKCA marking		Self-declaration			Self-declaration			Self-declaration			Self-declaration			Self-declaration					
CCC		Certified			Certified			Certified			Certified			Certified					
Marine use approval (☆:Certified) (NK, LR, ABS, DNV)		☆	-	☆	-	☆	-	☆	-	☆	-	☆	-	☆	-	☆	-		
Automatic tripping device		Thermal-magnetic			Electronic (effective value detection)			Thermal-magnetic			Electronic (effective value detection)			Thermal-magnetic					
Trip button		Equipped			Equipped			Equipped			Equipped			Equipped					
Page of Characteristics and dimensions		156			158			160			162			166					

- Notes:
- The operating characteristics are different between AC and DC.
  - For 3-pole product, connect cables/busbars to any two terminals, and for 4-pole product, connect cables/busbars to any two terminals except N-pole.  
When connected cables/busbars as shown on the right, maximum of 400VDC can be applied to 3-pole product and maximum of 500VDC to 4-pole product.
  - This accessory is cassette type and can be installed by customer. The frame size up to 250A can be closely installed, except for those with UVT.
  - For 3-pole product, connect cables/busbars to any two terminals, and for 4-pole product, connect cables/busbars to any two terminals except N-pole.  
Not available for use with connection as shown on the right.
  - Solid state relay output is available as an option. Specify if this contact output is required. Lead-wire terminal block (SLT) is equipped as standard. AS for flush plate type, an outline differs from a standard.
  - Place an order with circuit breaker.
  - No isolation function except 400A to 800A frame.

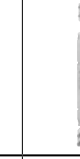

**NF-S (Standard class)**

630		800		800		1000		1250		1250		1600		1600	
NF630-SEW		NF800-SEW		NF800-SDW		NF1000-SEW		NF1250-SEW		NF1250-SDW		NF1600-SEW		NF1600-SDW	
															
Adjustable 300 350 400 500 600 630		Adjustable 400 450 500 600 700 800		(700) 800		Adjustable 500 600 700 800 900 1000		Adjustable 600 700 800 1000 1200 1250		1000 1250		Adjustable 800 1000 1200 1400 1500 1600		1600	
3 4		3 4		2		3 4		3 4		2		3 4		2	
690		690		690		690		690		690		690		690	
10/10		10/10		-		25/13		25/13		-		25/13		-	
30/30		30/30		-		65/33		65/33		-		65/33		-	
42/42		42/42		-		85/43		85/43		-		85/43		-	
50/50		50/50		-		85/43		85/43		-		85/43		-	
50/50		50/50		-		85/43		85/43		-		85/43		-	
50/50		50/50		-		85/43		85/43		-		85/43		-	
85/85		85/85		-		125/63		125/63		-		125/63		-	
85/85		85/85		-		125/63		125/63		-		125/63		-	
-		-		40/40		-		-		40/20		-		40/20	
8		8		8		8		8		8		8		8	
AC		AC		DC		AC		AC		DC		AC		DC	
Yes		Yes		Yes		Yes		Yes		Yes		Yes		Yes	
Available		Available		Available		Available		Available		Available		Available		Available	
6,000		4,000		4,000		3,000		3,000		3,000		3,000		3,000	
1,000		500		500		500		500		500		500		500	
B		B		A		B		B		A		B		A	
7.6		9.6		-		20 at 0.1		20 at 0.1		-		20 at 0.1		-	
3		3		3		3		3		3		3		3	
A		A		Not Applicable		A		A		Not Applicable		A		Not Applicable	
140 185		210 280		210		210 280		210 280		210 280		210 280		210	
257		275		275		406		406		406		406		406	
103		103		103		140		140		140		140		140	
155		155		155		190		190		190		190		190	
6.5 8.3		10.9 14.2		9.0		23.5 30.7		23.5 30.7		22.0		34.5 41.2		32.0	
●Busbar terminal		●Busbar terminal		●Busbar terminal		●Busbar terminal ●Busbar terminal		●Busbar terminal ●Busbar terminal		●Busbar terminal		●Busbar terminal ●Busbar terminal		●Busbar terminal	
●Bar stud ●Bar stud		●Bar stud ●Bar stud		●Bar stud		●Bar stud ●Bar stud		●Bar stud ●Bar stud		●Bar stud		●Bar stud ●Bar stud		●Bar stud	
● (*3)		● (*3)		●		● ●		● ●		●		● ●		●	
● (*3)		● (*3)		●		● ●		● ●		●		● ●		●	
● (*3)		● (*3)		●		● ●		● ●		●		● ●		●	
● (*3)		● (*3)		●		● ●		● ●		●		● ●		●	
● (*5)		● (*5)		-		● (*5)		● (*5)		-		● (*5)		-	
●		●		●		-		-		-		-		-	
● (*6)		● (*6)		● (*6)		● (*6)		● (*6)		● (*6)		● (*6)		● (*6)	
●		●		●		-		-		-		-		-	
●		●		●		-		-		-		-		-	
●		●		●		-		-		-		-		-	
●		●		●		-		-		-		-		-	
●		●		●		-		-		-		-		-	
-		-		-		-		-		-		-		-	
Self-declaration		Self-declaration		Self-declaration		Self-declaration		Self-declaration		Self-declaration		Self-declaration		Self-declaration	
Self-declaration		Self-declaration		Self-declaration		Self-declaration		Self-declaration		Self-declaration		Self-declaration		Self-declaration	
Certified		Certified		Certified		Certified		Certified		-		Certified		-	
☆		-		☆		-		☆		-		-		-	
Electronic (effective value detection)		Electronic (effective value detection)		Thermal-magnetic		Electronic (effective value detection)		Electronic (effective value detection)		Thermal-magnetic		Electronic (effective value detection)		magnetic	
Equipped		Equipped		Equipped		Equipped		Equipped		Equipped		Equipped		Equipped	
168		170		172		176		176		178		180		182	

Remarks: 1. Products with rated current parenthesized are produced when an order is placed.  
2. Specify "P-LT" when selecting plug-in type with lead-wire terminal block.  
3. The circuit breaker has the rated short-circuit breaking capacity specified in the shaded cells.

## NF-L / NF-H / NF-R (High-performance class)

Frame (A)		50			60			63			100			125			125			125			125				
Model		NF63-HV									NF125-HV						NF125-LGV			NF125-HGV			NF125-RGV				
Image																											
Rated current In (A) Reference ambient temperature 40°C (45°C for marine use)		10 (15) 16 20 25 30 32 40 50			(60)			63			(15) 16 20 (30) 32 40 50 (60) 63 (75) 80 100			125			16-20 20-25 25-32 32-40 35-50 45-63 56-80 70-100 90-125			16-20 20-25 25-32 32-40 35-50 45-63 56-80 70-100 90-125			16-20 20-25 25-32 32-40 40-50 50-63 63-80 80-100 100-125				
Number of poles		2 3 4			2 3 4			2 3 4			2 3 4			2 3 4			2 3 4			2 3 4			2 3				
Rated insulation voltage Ui (V)		690									690						690			690			690				
Rated short-circuit breaking capacities (kA) IEC 60947-2 EN 60947-2 (Icu/Ics)	AC	690V	2.5/2.5			2.5/2.5			2.5/2.5			10/8			10/8			8/8			10/8			-			
		500V	7.5/7.5			7.5/7.5			7.5/7.5			30/23			30/23			36/36			50/38			-			
		440V	10/8			10/8			10/8			50/38			50/38			50/50			65/65			125/125			
		415V	10/8			10/8			10/8			50/38			50/38			50/50			70/70			150/150			
		400V	10/8			10/8			10/8			50/38			50/38			50/50			75/75			150/150			
		380V	10/8			10/8			10/8			50/38			50/38			50/50			75/75			150/150			
		230V	25/19			25/19			25/19			100/75			100/75			90/90			100/100			150/150			
		200V	25/19			25/19			25/19			100/75			100/75			90/90			100/100			150/150			
DC	250V	7.5/7.5 (*5)			7.5/7.5 (*5)			7.5/7.5 (*5)			-			-			20/20 (300V) (*2)			40/40 (300V) (*2)			-				
Rated impulse withstand voltage Uimp (kV)		8									8						8			8			8				
Current		AC/DC compatible (*1)									AC/DC compatible (*1)						AC			AC/DC compatible			AC/DC compatible				
Suitability for isolation		Yes									Yes						Yes			Yes			Yes				
Reverse connection		Available									Available						Available			Available			Available				
Number of operating cycles		Without current		15,000			15,000			15,000			25,000			25,000			50,000			50,000			50,000		
		With current (440VAC)		8,000			8,000			8,000			10,000			10,000			30,000			30,000			30,000		
Selectivity category		A									A						A			A			A				
Pollution degree		3									3						3			3			3				
EMC environment condition (environment A or B)		Not Applicable									Not Applicable						Not Applicable			Not Applicable			Not Applicable				
Overall dimensions (mm)		a	50	75	100	50	75	100	50	75	100	90	120	90	120	105	140	105	140	105	140	105	140				
		b	130			130			130			130			165			165			165						
		c	68			68			68			68			68			68			68						
		ca	90			90			90			90			92			92			92						
Mass of front-face type (kg)		0.5	0.7	0.9	0.55	0.75	1.0	0.55	0.75	1.0	0.8	1.0	1.3	0.8	1.0	1.3	1.4	1.6	2.0	1.4	1.6	2.0	1.5	1.8			
Installation and connections	Front connection (F)	●Screw terminal																									
	Solderless (BOX) terminal (SL)	●																									
Rear	(B)	●Round stud									●Round stud						●Bar stud			●Bar stud			●Bar stud				
	Plug-in (PM)	●																									
Cassette-type accessories	Alarm switch (AL)	● (*3)			● (*3)			● (*3)			● (*3)			● (*3)			● (*3)			● (*3)			● (*3)				
	Auxiliary switch (AX)	● (*3)			● (*3)			● (*3)			● (*3)			● (*3)			● (*3)			● (*3)			● (*3)				
	Shunt trip (SHT)	● (*3)			● (*3)			● (*3)			● (*3)			● (*3)			● (*3)			● (*3)			● (*3)				
	Undervoltage trip (UVT)	● (*3)			● (*3)			● (*3)			● (*3)			● (*3)			● (*3)			● (*3)			● (*3)				
	With lead-wire terminal block (SLT)	●																									
	Pre-alarm (PAL)	-																									
External accessories	Enclosure	Closed (S)	●																								
		Dustproof (I)	●																								
	Waterproof (W)	-																									
		-																									
	Electrical operation device (NFM)	-																									
		-																									
	Mechanical interlock (MI) (*4)	Panel mounting	●			●			●			●			●			●			●			●			
		Breaker mounting	●			●			●			●			●			●			●			●			
	Lock cover	LC	●																								
		-																									
Handle lock device	HL	●																									
	HL-S	●																									
External operating handle	(F)	●																									
	(V)	●																									
Terminal cover (TC-L, TC-S, TTC, BTC, PTC)	●																										
Rear stud (B-ST)	-																										
Plug-in (PM)	●																										
IEC 35mm rail mounting adapters	-																										
CE marking		Self-declaration																									
UKCA marking		Self-declaration																									
CCC		Certified																									
Marine use approval (☆:Certified) (NK, LR, ABS, DNV)		☆			☆			☆			☆			☆			☆ (LR, ABS, DNV)			☆ (LR, ABS, DNV)			☆ (LR, ABS, DNV)				
Automatic tripping device		Thermal-magnetic																									
Trip button		Equipped																									
Page of Characteristics and dimensions		146									148						156			156			156				

- Notes:
- \*1 The operating characteristics are different between AC and DC.
  - \*2 For 3-pole product, connect cables/busbars to any two terminals, and for 4-pole product, connect cables/busbars to any two terminals except N-pole.  
When connected cables/busbars as shown on the right, maximum of 500VDC can be applied to 3-pole product and maximum of 600VDC to 4-pole product.
  - \*3 This accessory is cassette type and can be installed by customer. The frame size up to 250A can be closely installed, except for those with UVT.
  - \*4 No isolation function except 400A to 800A frame.
  - \*5 For 3-pole product, connect cables/busbars to any two terminals, and for 4-pole product, connect cables/busbars to any two terminals except N-pole.  
Not available for use with connection as shown on the right.
  - \*6 For HEV with PAL, it will be an exclusive item.  
When ordering only the terminal cover, specify the model name with MP at the end.

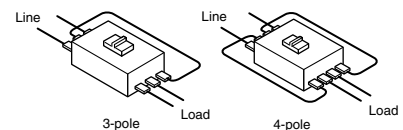



## NF-H / NF-R (High-performance class)

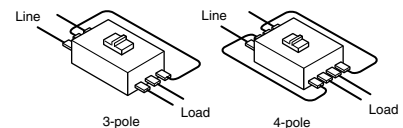

Frame (A)	250		400		630		800	
Model	NF250-HEV	NF400-HEV	NF400-REW	NF630-HEV	NF630-REW	NF800-HEV	NF800-REW	
Image								
Rated current In (A) Reference ambient temperature 40°C (45°C for marine use)	Adjustable 80-160 (8A step) 125-250 (12.5A step)	Adjustable 200 225 250 300 350 400	Adjustable 200 225 250 300 350 400	Adjustable 300 350 400 500 600 630	Adjustable 300 350 400 500 600 630	Adjustable 400 450 500 600 700 800	Adjustable 400 450 500 600 700 800	
Number of poles	3 4	3 4	3	3 4	3	3 4	3	
Rated insulation voltage Ui (V)	690		690	690	690	690		
Rated short-circuit breaking capacities (kA) IEC 60947-2 EN 60947-2 (Icu/Ics) AC DC 250V	690V	10/8	35/18	-	35/18	-	15/15	
	500V	50/38	50/50	70/35	50/50	70/35	50/50	
	440V	65/65	65/65	125/63	65/65	125/63	65/65	
	415V	70/70	70/70	125/63	70/70	125/63	70/70	
	400V	75/75	70/70	125/63	70/70	125/63	70/70	
	380V	75/75	70/70	125/63	70/70	125/63	70/70	
	230V	100/100	100/100	150/75	100/100	150/75	100/100	
	200V	100/100	100/100	150/75	100/100	150/75	100/100	
Rated impulse withstand voltage Uimp (kV)	8		8	8	8	8		
Current	AC		AC	AC	AC	AC		
Suitability for isolation	Yes		Yes	Yes	Yes	Yes		
Reverse connection	Available		Available	Available	Available	Available		
Number of operating cycles	Without current	25,000	6,000	6,000	6,000	6,000	4,000	
	With current (440VAC)	10,000	1,000	1,000	1,000	1,000	500	
Selectivity category	A		B	B	B	B		
Rated short time with stand current Icu (kA) at 0.25s	-		5	5	7.6	7.6	9.6	
Pollution degree	3		3	3	3	3		
EMC environment condition (environment A or B)	A		A	A	A	A		
Overall dimensions (mm)	a	105 140	140 185	140	140 185	140	210 280	
	b	165	257	257	257	257	275	
	c	68	103	103	103	103	103	
	ca	92	155	155	155	155	155	
Mass of front-face type (kg)	1.7 2.2	6.0 7.6	6.0	6.5 8.3	6.0	10.9 14.2	10.9	
Installation and connections	Front connection (F)	Page	●Screw terminal	●Busbar terminal	●Busbar terminal	●Busbar terminal ●Busbar terminal	●Busbar terminal ●Busbar terminal	●Busbar terminal
	Solderless (BOX) terminal (SL)	98	●Bar stud ●Bar stud	-	-	-	-	-
	Rear (B)		●Bar stud	●Bar stud	●Bar stud	●Bar stud ●Bar stud	●Bar stud ●Bar stud	●Bar stud
	Plug-in (PM)		●	●	●	●	●	●
Cassette-type accessories	Alarm switch (AL)	115	●(*1)	●(*1)	●(*1)	●(*1)	●(*1)	●(*1)
	Auxiliary switch (AX)		●(*1)	●(*1)	●(*1)	●(*1)	●(*1)	●(*1)
	Shunt trip (SHT)		●(*1)	●(*1)	●(*1)	●(*1)	●(*1)	●(*1)
	Undervoltage trip (UVT)		●(*1)	●	●	●	●	●
	With lead-wire terminal block (SLT)	120	●	●	●	●	●	●
	Pre-alarm (PAL)	122	●	●(*2)	●(*2)	●(*2)	●(*2)	●(*2)
External accessories	Enclosure	137	●	-	-	-	-	-
	Dustproof (I)		●	-	-	-	-	-
	Waterproof (W)		●	-	-	-	-	-
	Electrical operation device (NFM)	140	●	●(*3)	●(*3)	●(*3)	●(*3)	●(*3)
	Mechanical interlock (MI) (*4)	136	●	●	●	●	●	●
	Panel mounting Breaker mounting		●	-	-	-	-	-
	Lock cover LC		●	-	-	-	-	-
	Handle lock device HL	134	●	●	●	●	●	●
	HL-S		●	●	●	●	●	●
	External operating handle (F)	123	●	●	●	●	●	●
(V)		●	●	●	●	●	●	
Terminal cover (TC-L, TC-S, TTC, BTC, PTC)	128	●(*5)	●(*5)	●	●	●	●	
Rear stud (B-ST)	100	●	●	●	●	●	●	
Plug-in (PM)		●	●	●	●	●	●	
IEC 35mm rail mounting adapters	143	-	-	-	-	-	-	
CE marking	Self-declaration	Self-declaration	Self-declaration	Self-declaration	Self-declaration	Self-declaration	Self-declaration	
UKCA marking	Self-declaration	Self-declaration	Self-declaration	Self-declaration	Self-declaration	Self-declaration	Self-declaration	
CCC	Certified	Certified	Certified	Certified	Certified	Certified	Certified	
Marine use approval (☆:Certified) (NK, LR, ABS, DNV)	☆ (LR, ABS, DNV)	-	☆	-	☆	☆	-	☆
Automatic tripping device	Electronic (effective value detection)	Electronic (effective value detection)	Electronic (effective value detection)	Electronic (effective value detection)	Electronic (effective value detection)	Electronic (effective value detection)	Electronic (effective value detection)	
Trip button	Equipped	Equipped	Equipped	Equipped	Equipped	Equipped	Equipped	
Page of Characteristics and dimensions	158	162	162	168	168	170	170	

- Notes: \*1 This accessory is cassette type and can be installed by customer. The frame size up to 250A can be closely installed, except for those with UVT.  
 \*2 Solid state relay output is available as an option. Specify if this contact output is required. Lead-wire terminal block (SLT) is equipped as standard.  
 \*3 Place an order with circuit breaker.  
 \*4 No isolation function except 400A to 800A frame.  
 \*5 For HEV with PAL, it will be an exclusive item.  
 When ordering only the terminal cover, specify the model name with MP at the end.





## NV-C (Economy class) Harmonic Surge Ready

Frame (A)		50		60		63		100		125		
Model		NV63-CV						NV125-CV				
Image												
Rated current In (A) Reference ambient temperature 40°C		(5) (10) (15) 16 20 25 (30) 32 40 50		(60)		63		(60) 63 (75) 80 100		125		
Number of poles		2 3		2 3		2 3		3		3		
Phase line (*1)		1φ2W 3φ3W, 1φ3W, 1φ2W		1φ2W 3φ3W, 1φ3W, 1φ2W		1φ2W 3φ3W, 1φ3W, 1φ2W		3φ3W, 1φ3W, 1φ2W		3φ3W, 1φ3W, 1φ2W		
Rated operational voltage Ue (V) (*2) AC		100-240 100-440		100-240 100-440		100-240 100-440		100-440		100-440		
High-speed type	Rated current sensitivity (mA)	30 30,100/200/500 selectable		30 30,100/200/500 selectable		30 30,100/200/500 selectable		30,100/200/500 selectable		30,100/200/500 selectable		
	Max. operating time (s) at IΔn at 5IΔn	0.1 0.04		0.1 0.04		0.1 0.04		0.1 0.04		0.1 0.04		
Time-delay type	Rated current sensitivity (mA)	-		-		-		(100/200/500 selectable)		(100/200/500 selectable)		
	Max. operating time (s) (*3)	-		-		-		(0.45/1.0/2.0 selectable)		(0.45/1.0/2.0 selectable)		
	Internal non-operating (s) (or more)	-		-		-		(0.1/0.5/1.0)		(0.1/0.5/1.0)		
Earth leakage protection characteristic		Type A										
Earth leakage indication system		Mechanical type (button)		Mechanical type (button)		Mechanical type (button)		Mechanical type (button)		Mechanical type (button)		
Rated short-circuit breaking capacities (kA)	AC	440V - 2.5/2.5		440V - 2.5/2.5		440V - 2.5/2.5		440V - 2.5/2.5		440V - 2.5/2.5		
	IEC 60947-2	415V - 2.5/2.5		415V - 2.5/2.5		415V - 2.5/2.5		415V - 2.5/2.5		415V - 2.5/2.5		
	EN 60947-2 (Icu/Ics)	400V - 5/5		400V - 5/5		400V - 5/5		400V - 5/5		400V - 5/5		
	230V	7.5/7.5		7.5/7.5		7.5/7.5		7.5/7.5		7.5/7.5		
	200V	7.5/7.5		7.5/7.5		7.5/7.5		7.5/7.5		7.5/7.5		
	100V	7.5/7.5		7.5/7.5		7.5/7.5		7.5/7.5		7.5/7.5		
Rated impulse withstand voltage Uimp (kV)		6 AC		6 AC		6 AC		6 AC		6 AC		
Suitability for isolation		Yes		Yes		Yes		Yes		Yes		
Reverse connection (below 230VAC)		Available		Available		Available		Available		Available		
Number of operating cycles	Without current	10,000		10,000		10,000		10,000		10,000		
	With current	6,000		6,000		6,000		6,000		6,000		
Selectivity category		A		A		A		A		A		
Pollution degree		2		2		2		2		2		
EMC environment condition (environment A or B)		A		A		A		A		A		
Overall dimensions (mm)	a	75		75		75		90		90		
	b	130		130		130		130		130		
	c	68		68		68		68		68		
	ca	90		90		90		90		90		
	Mass of front-face type (kg)	0.7 0.75		0.7 0.75		0.7 0.75		1.0		1.0		
Installation and connections	Front connection (F)	Page		●Screw terminal		●Screw terminal		●Screw terminal		●Screw terminal		
	Solderless (BOX) terminal (SL)	98		-		-		-		-		
	Rear (B)	●Round stud		●Round stud		●Round stud		●Bar stud		●Bar stud		
	Plug-in (PM)	●		●		●		●		●		
Cassette-type accessories	Alarm switch (AL)	●(*4)		●(*4)		●(*4)		●(*4)		●(*4)		
	Auxiliary switch (AX)	●(*4)		●(*4)		●(*4)		●(*4)		●(*4)		
	Shunt trip (SHT)	●(*4)		●(*4)		●(*4)		●(*4)		●(*4)		
	Undervoltage trip (UVT)	●(*4)		●(*4)		●(*4)		●(*4)		●(*4)		
	With lead-wire terminal block (SLT)	120		●		●		●		●		
Test button module (TBM)	121		●(*5)		●(*5)		●(*5)		●(*5)			
External accessories	Enclosure	Closed (S)		-		-		-		-		
	Dustproof (I)	-		-		-		-		-		
		Waterproof (W)		-		-		-		-		
	Electrical operation device (NFM)	-		-		-		●		●		
		Mechanical interlock (MI) (*7) Breaker mounting	136		●		●		●		●	
	Lock cover	LC	●		●		●		●		●	
		HL	●		●		●		●		●	
	Handle lock device	HL-S	●		●		●		●		●	
		(F)	123		●		●		●		●	
	External operating handle (V)	123		●		●		●		●		
Terminal cover (TC-L, TC-S, TTC, BTC, PTC)	128		●		●		●		●			
Rear stud (B-ST)	100		●		●		●		●			
Plug-in (PM)	-		-		-		-		-			
IEC 35mm rail mounting adapters	143		●		●		-		-			
CE marking		Self-declaration		Self-declaration		Self-declaration		Self-declaration		Self-declaration		
UKCA marking		Self-declaration		Self-declaration		Self-declaration		Self-declaration		Self-declaration		
CCC marking		Certified		Certified		Certified		Certified		Certified		
Marine use approval (NK, LFR, ABS, DNV)		-		-		-		-		-		
Automatic tripping device		Thermal-magnetic		Thermal-magnetic		Thermal-magnetic		Thermal-magnetic		Thermal-magnetic		
Trip button		Equipped		Equipped		Equipped		Equipped		Equipped		
Page of Characteristics and dimensions		184		184		184		186		186		

Notes: \*1 When using 3-pole earth-leakage circuit breakers for 1-phase 2-wire system, connect cables/busbars to left and right poles, not to center pole. When using 1-phase 3-wire system, connect neutral conductor to center pole of earth leakage circuit breaker.  
 \*2 For time-delay type, the rated voltage is 200-440VAC.  
 \*3 When the operating time are 0.45, 1.0 and 2.0 seconds, the Earth Leakage circuit breaker operates between 0.15 and 0.45 seconds, between 0.6 and 1.0 seconds and between 1.2 and 2.0 seconds respectively.  
 \*4 This accessory is cassette type and can be installed by customer. The frame size up to 250A can be closely installed, except for those with UVT.  
 \*5 Standard type is SLT equipped.

\*6 Place an order with circuit breaker.  
 \*7 No isolation function except 400A to 630A frame.  
 \*8 AC100V does not acquire the CCC certification.

**NV-C (Economy class) Harmonic Surge Ready**

225		250		400		600		630	
NV250-CV		NV250-CV		NV400-CW		NV400-CW		NV630-CW	
125 150 175 200 225		250		250 300 350 400		500 600		(630)	
3		3		3		3		3	
3φ3W, 1φ3W, 1φ2W		3φ3W, 1φ3W, 1φ2W		3φ3W, 1φ3W, 1φ2W		3φ3W, 1φ3W, 1φ2W		3φ3W, 1φ3W, 1φ2W	
100-440		100-440		100-440		200-440		200-440	
30,100/200/500 selectable		30,100/200/500 selectable		(30),100/200/500 selectable		-		-	
0.1		0.1		0.1		-		-	
0.04		0.04		0.04		-		-	
(100/200/500 selectable)		(100/200/500 selectable)		(100/200/500 selectable)		(100/200/500 selectable)		(100/200/500 selectable)	
(0.45/1.0/2.0 selectable)		(0.45/1.0/2.0 selectable)		(0.45/1.0/2.0 selectable)		(0.45/1.0/2.0 selectable)		(0.45/1.0/2.0 selectable)	
(0.1/0.5/1.0)		(0.1/0.5/1.0)		(0.1/0.5/1.0)		(0.1/0.5/1.0)		(0.1/0.5/1.0)	
Type A		Type A		Type AC		Type AC		Type AC	
Mechanical type (button)		Mechanical type (button)		Mechanical type (button)		Mechanical type (button)		Mechanical type (button)	
15/12		15/12		25/13		36/18		36/18	
25/19		25/19		36/18		36/18		36/18	
25/19		25/19		36/18		36/18		36/18	
36/27		36/27		50/25		50/25		50/25	
36/27		36/27		50/25		50/25		50/25	
36/27		36/27		50/25		-		-	
6		6		8		8		8	
AC		AC		AC		AC		AC	
Yes		Yes		Yes		Yes		Yes	
Available		Available		Available		Available		Available	
8,000		8,000		6,000		6,000		6,000	
4,000		4,000		1,000		1,000		1,000	
A		A		A		A		A	
2		2		3		3		3	
A		A		A		A		A	
105		105		140		140		140	
165		165		257		257		257	
68		68		103		103		103	
92		92		134		155		155	
1.7		1.7		6.1		6.9		6.9	
●Screw terminal		●Screw terminal		●Busbar terminal		●Busbar terminal		●Busbar terminal	
-		-		-		-		-	
●Bar stud		●Bar stud		●Bar stud		●Bar stud		●Bar stud	
●		●		●		●		●	
●(*4)		●(*4)		●(*4)		●(*4)		●(*4)	
●(*4)		●(*4)		●(*4)		●(*4)		●(*4)	
●(*4)		●(*4)		●(*4)		●(*4)		●(*4)	
●(*4)		●(*4)		●(*4)		●(*4)		●(*4)	
●		●		●		●		●	
●(*5)		●(*5)		●(*5)		●(*5)		●(*5)	
-		-		-		-		-	
-		-		-		-		-	
-		-		-		-		-	
●		●		●(*6)		●(*6)		●(*6)	
●		●		●		●		●	
●		●		●		●		●	
●		●		●		●		●	
●		●		●		●		●	
●		●		●		●		●	
●		●		●		●		●	
●		●		●		●		●	
●		●		●		●		●	
-		-		-		-		-	
-		-		-		-		-	
TÜV approval		TÜV approval		Self-declaration		Self-declaration		Self-declaration	
Self-declaration		Self-declaration		Self-declaration		Self-declaration		Self-declaration	
Certified		Certified		Certified		Certified		Certified	
-		-		-		-		-	
Thermal-magnetic		Thermal-magnetic		Thermal-magnetic		Thermal-magnetic		Thermal-magnetic	
Equipped		Equipped		Equipped		Equipped		Equipped	
188		188		192		196		196	

Remarks: 1. Products with rated current parenthesized are produced when an order is placed.  
 2. Specify "P-LT" when selecting plug-in type with lead-wire terminal block.  
 3. The circuit breaker has the rated short-circuit breaking capacity specified in the shaded cells.

Rated operational voltage	Applicable circuit voltage	Available voltage range
100-240V	100/110/200/220/230/240V	85-264V
100-440V	100/110/200/220/240/254/265/380/400/415/440V	85-484V
200-440V	200/220/240/254/265/380/400/415/440V	170-484V

2 Detailed Specifications

## NV-S (Standard class) Harmonic Surge Ready

Frame (A)		30	32	50	60	63	100	125	125	
Model		NV32-SV			NV63-SV		NV125-SV		NV125-SEV	
Image										
Rated current In (A)		(5) 6 10 (15)	(32)	(5) (10) (15) 16 20	(60)	63	(15) 16 20 (30) 32 40 50	125	Adjustable 63-125	
Reference ambient temperature 40°C		16 20 25 (30)		25 (30) 32 40 50			(60) 63 (75) 80 100 (*3)		(6.25A step)	
Number of poles		3	3	3	3	3	3 4	3 4	3 4	
Phase line (*1)		3φ3W, 1φ3W, 1φ2W	3φ3W, 1φ3W, 1φ2W	3φ3W, 1φ3W, 1φ2W	3φ3W, 1φ3W, 1φ2W	3φ3W, 1φ3W, 1φ2W	3φ3W, 1φ3W, 1φ2W 3φ4W	3φ3W, 1φ3W, 1φ2W 3φ4W	3φ3W, 1φ3W, 1φ2W 3φ4W	
Rated operational voltage Ue (V) (*2) AC		100-440								
High-speed type	Rated current sensitivity (mA)	30,100/200/500 selectable								
	Max. operating time (s)	0.1 at IΔn 0.04 at 5IΔn								
Time-delay type	Rated current sensitivity (mA)	-								
	Max. operating time (s) (*4)	-								
Internal non-operating (s) (or more)		-								
Earth leakage protection characteristic		Type A			Type A			Type A		Type A
Earth leakage indication system		Mechanical type (button)			Mechanical type (button)			Mechanical type (button)		Mechanical type (button)
Rated short-circuit breaking capacities (kA)	AC	440V	5/5	5/5	7.5/7.5	7.5/7.5	7.5/7.5	25/25	25/25	36/36
		415V	5/5	5/5	7.5/7.5	7.5/7.5	7.5/7.5	30/30	30/30	36/36
		400V	5/5	5/5	7.5/7.5	7.5/7.5	7.5/7.5	30/30	30/30	36/36
		230V	10/10	10/10	15/15	15/15	15/15	50/50	50/50	85/85
		200V	10/10	10/10	15/15	15/15	15/15	50/50	50/50	85/85
		100V	10/10	10/10	15/15	15/15	15/15	50/50	50/50	85/85
Rated impulse withstand voltage Uimp (kV)		6	6	6	6	6	6	6	6	
Current		AC	AC	AC	AC	AC	AC	AC	AC	
Suitability for isolation		Yes	Yes	Yes	Yes	Yes	Yes	Yes	Yes	
Reverse connection (below 230VAC)		Available	Available	Available	Available	Available	Available	Available	Available	
Number of operating cycles	Without current	10,000	10,000	15,000	15,000	15,000	25,000	25,000	25,000	
	With current	6,000	6,000	8,000	8,000	8,000	10,000	10,000	10,000	
Selectivity category		A	A	A	A	A	A	A	A	
Rated short time withstand current Icu (kA) at 0.25s		-	-	-	-	-	-	-	-	
Pollution degree		2	2	2	2	2	2	2	2	
EMC environment condition (environment A or B)		A	A	A	A	A	A	A	A	
Overall dimensions (mm)	a	75	75	75	75	75	90 120	90 120	105 140	
	b	130	130	130	130	130	130	130	165	
	c	68	68	68	68	68	68	68	68	
	ca	90	90	90	90	90	90	90	92	
Mass of front-face type (kg)		0.75	0.75	0.75	0.8	0.8	1.1 1.4	1.1 1.4	1.9 2.5	
Installation and connections	Front connection (F)	Page	●Screw terminal	●Screw terminal	●Screw terminal	●Screw terminal	●Screw terminal	●Screw terminal	●	
	Solderless (BOX) terminal (SL)	-	-	-	-	-	-	-	-	
	Rear connection (B)	98	●Round stud	●Round stud	●Round stud	●Round stud	●Round stud	●Bar stud	●Bar stud	
	Plug-in (PM)	-	●	●	●	●	●	●	●	
Cassette-type accessories	Alarm switch (AL)	115	●(*5)	●(*5)	●(*5)	●(*5)	●(*5)	●(*5)	●(*5)	
	Auxiliary switch (AX)	●(*5)	●(*5)	●(*5)	●(*5)	●(*5)	●(*5)	●(*5)	●(*5)	
	Shunt trip (SHT)	●(*5)	●(*5)	●(*5)	●(*5)	●(*5)	●(*5)	●(*5)	●(*5)	
	Undervoltage trip (UVT)	●(*5)	●(*5)	●(*5)	●(*5)	●(*5)	●(*5)	●(*5)	●(*5)	
	With lead-wire terminal block (SLT)	120	●	●	●	●	●	●	●	
Test button module (TBM)	121	●(*6)	●(*6)	●(*6)	●(*6)	●(*6)	●(*6)	●(*6)		
External accessories	Enclosure	Closed (S)	137	-	-	-	-	-	●	-
		Dustproof (I)	-	-	-	-	-	-	●	-
		Waterproof (W)	-	-	-	-	-	-	●	-
	Electrical operation device (NFM)	Mechanical interlock (MI) (*8)	136	●	●	●	●	●	●	●
		Breaker mounting	●	●	●	●	●	●	●	●
	Lock cover	LC	134	●	●	●	●	●	●	●
		HL	●	●	●	●	●	●	●	●
	Handle lock device	HL-S	●	●	●	●	●	●	●	●
		(F)	●	●	●	●	●	●	●	●
	External operating handle	(V)	123	●	●	●	●	●	●	●
(V)		●	●	●	●	●	●	●	●	
Terminal cover (TC-L, TC-S, TTC, BTC, PTC)	128	●	●	●	●	●	●	●	●	
Rear stud (B-ST)	100	●	●	●	●	●	●	●	●	
Plug-in (PM)	100	-	-	-	-	-	-	-	-	
IEC 35mm rail mounting adapters	143	●	●	●	●	●	●	●	●	
CE marking		Self-declaration	Self-declaration	Self-declaration	Self-declaration	Self-declaration	Self-declaration	Self-declaration	Self-declaration	
UKCA marking		Self-declaration	Self-declaration	Self-declaration	Self-declaration	Self-declaration	Self-declaration	Self-declaration	Self-declaration	
CCC		Certified	Certified	Certified	Certified	Certified	Certified	Certified	Certified	
Marine use approval (NK, LR, ABS, DNV)		-	-	-	-	-	-	-	-	
Automatic tripping device		Thermal-magnetic	Thermal-magnetic	Thermal-magnetic	Thermal-magnetic	Thermal-magnetic	Thermal-magnetic	Thermal-magnetic	Electronic (effective value detection)	
Trip button		Equipped	Equipped	Equipped	Equipped	Equipped	Equipped	Equipped	Equipped	
Page of Characteristics and dimensions		184			184			186		190

Notes: \*1 When using 3-pole earth-leakage circuit breakers for 1-phase 2-wire system, connect cables/busbars to left and right poles, not to center pole. When using 1-phase 3-wire system, connect neutral conductor to center pole of earth leakage circuit breaker.

\*2 For time-delay type, the rated voltage is 200-440VAC.

\*3 In case of time delay type, rated current is produced with 20 amp. or more.

\*4 When the operating time are 0.45, 1.0 and 2.0 seconds, the Earth Leakage circuit breaker operates between 0.15 and 0.45 seconds, between 0.6 and 1.0 seconds and between 1.2 and 2.0 seconds respectively.

\*5 This accessory is cassette type and can be installed by customer. The frame size up to 250A can be closely installed, except for those with UVT.







\*6 Standard type is SLT equipped.

\*7 Place an order with circuit breaker.

\*8 No isolation function except 400A to 800A frame.

\*9 100VAC does not acquire the CCC certification.

**NV-S (Standard class) Harmonic Surge Ready**

225		250		250		400		400		600		630		630		800											
NV250-SV				NV250-SEV				NV400-SW				NV400-SEW				NV630-SW				NV630-SEW				NV800-SEW			
																											
125 150 175 200 225		250		Adjustable 125-250 (12.5A step)		250 300 350 400		Adjustable 200 225 250 300 350 400		500 600		(630)		Adjustable 300 350 400 500 600 630		Adjustable 400 450 500 600 700 800											
3 4		3 4		3		3		3 4		3		3		3 4		3											
3φ3W, 1φ3W, 1φ2W		3φ4W		3φ3W, 1φ3W, 1φ2W		3φ3W, 1φ3W, 1φ2W		3φ3W, 1φ3W, 1φ2W		3φ4W		3φ3W, 1φ3W, 1φ2W		3φ3W, 1φ3W, 1φ2W		3φ4W											
100-440		200-440		100-440		100-440		100-440		200-440		200-440		200-440		200-440											
(30),100/200/500 selectable		(30),100/200/500 selectable		(30),100/200/500 selectable		(30),100/200/500 selectable		(30),100/200/500 selectable		-		-		-		-											
0.1 0.04		0.1 0.04		0.1 0.04		0.1 0.04		0.1 0.04		-		-		-		-											
(100/200/500selectable)		(100/200/500selectable)		(100/200/500selectable)		(100/200/500selectable)		(100/200/500selectable)		100/200/500selectable		100/200/500selectable		(100/200/500selectable)		100/200/500selectable											
(0.45/1.0/2.0selectable)		(0.45/1.0/2.0selectable)		(0.45/1.0/2.0selectable)		(0.45/1.0/2.0selectable)		(0.45/1.0/2.0selectable)		0.45/1.0/2.0selectable		0.45/1.0/2.0selectable		(0.45/1.0/2.0selectable)		0.45/1.0/2.0selectable											
(0.1/0.5/1.0)		(0.1/0.5/1.0)		(0.1/0.5/1.0)		(0.1/0.5/1.0)		(0.1/0.5/1.0)		0.1/0.5/1.0		0.1/0.5/1.0		(0.1/0.5/1.0)		0.1/0.5/1.0											
Type A		Type A		Type A		Type AC		Type AC		Type AC		Type AC		Type AC		Type AC											
Mechanical type (button)		Mechanical type (button)		Mechanical type (button)		Mechanical type (button)		Mechanical type (button)		Mechanical type (button)		Mechanical type (button)		Mechanical type (button)		Mechanical type (button)											
36/36		36/36		36/36		42/42		42/42		42/42		42/42		42/42		42/42											
36/36		36/36		36/36		45/45		50/50		50/50		50/50		50/50		50/50											
36/36		36/36		36/36		45/45		50/50		50/50		50/50		50/50		50/50											
85/85		85/85		85/85		85/85		85/85		85/85		85/85		85/85		85/85											
85/85		85/85		85/85		85/85		85/85		85/85		85/85		85/85		85/85											
85/85		85/85		85/85		85/85		85/85		85/85		85/85		85/85		85/85											
6		6		6		8		8		8		8		8		8											
AC		AC		AC		AC		AC		AC		AC		AC		AC											
Yes		Yes		Yes		Yes		Yes		Yes		Yes		Yes		Yes											
Available		Available		Available		Available		Available		Available		Available		Available		Available											
25,000		25,000		25,000		6,000		6,000		6,000		6,000		6,000		4,000											
10,000		10,000		10,000		1,000		1,000		1,000		1,000		1,000		500											
A		A		A		A		B		A		A		B		A											
-		-		-		-		5		-		-		7.6		9.6											
2		2		2		3		3		3		3		3		3											
A		A		A		A		A		A		A		A		A											
105 140		105 140		105		140		140 185		140		140		140 185		210											
165		165		165		257		257		257		257		257		275											
68		68		68		103		103		103		103		103		103											
92		92		92		155		155		155		155		155		155											
1.9 2.5		1.9 2.5		1.9		6.4		6.2 8.2		6.9		6.9		7.1 8.9		15.3											
●Screw terminal		●Screw terminal		●		●Busbar terminal		●Busbar terminal		●Busbar terminal		●Busbar terminal		●Busbar terminal		●Busbar terminal											
-		-		-		-		-		-		-		-		-											
●Bar stud		●Bar stud		●Bar stud		●Bar stud		●Bar stud		●Bar stud		●Bar stud		●Bar stud		●Bar stud											
-		-		-		-		-		-		-		-		-											
●(*5)		●(*5)		●(*5)		●(*5)		●(*5)		●(*5)		●(*5)		●(*5)		●(*5)											
●(*5)		●(*5)		●(*5)		●(*5)		●(*5)		●(*5)		●(*5)		●(*5)		●(*5)											
●(*5)		●(*5)		●(*5)		●(*5)		●(*5)		●(*5)		●(*5)		●(*5)		●(*5)											
●(*5)		●(*5)		●(*5)		●(*5)		●(*5)		●(*5)		●(*5)		●(*5)		●(*5)											
●(*6)		●(*6)		●(*6)		●(*6)		●(*6)		●(*6)		●(*6)		●(*6)		●(*6)											
-		-		-		-		-		-		-		-		-											
-		-		-		-		-		-		-		-		-											
●		●		●		●(*7)		●(*7)		●(*7)		●(*7)		●(*7)		●(*7)											
●		●		●		●		●		●		●		●		●											
●		●		●		●		●		●		●		●		●											
●		●		●		●		●		●		●		●		●											
●		●		●		●		●		●		●		●		●											
●		●		●		●		●		●		●		●		●											
●		●		●		●		●		●		●		●		●											
●		●		●		●		●		●		●		●		●											
-		-		-		-		-		-		-		-		-											
TUV approval		TUV approval		Self-declaration		Self-declaration		Self-declaration		Self-declaration		Self-declaration		Self-declaration		Self-declaration											
Self-declaration		Self-declaration		Self-declaration		Self-declaration		Self-declaration		Self-declaration		Self-declaration		Self-declaration		Self-declaration											
Certified		Certified		Certified		Certified		Certified		Certified		Certified		Certified		Certified											
-		-		-		-		-		-		-		-		-											
Thermal-magnetic		Thermal-magnetic		Electronic (effective value detection)		Thermal-magnetic		Electronic (effective value detection)		Thermal-magnetic		Thermal-magnetic		Electronic (effective value detection)		Electronic (effective value detection)											
Equipped		Equipped		Equipped		Equipped		Equipped		Equipped		Equipped		Equipped		Equipped											
188		190		192		194		196		198		200															

Remarks: 1. Products with rated current parenthesized are produced when an order is placed.  
 2. Specify "P-LT" when selecting plug-in type with lead-wire terminal block.  
 3. The circuit breaker has the rated short-circuit breaking capacity specified in the shaded cells.  
 4. 

Rated operational voltage	Applicable circuit voltage	Available voltage range
100-440V	100/110/200/220/240/254/265/380/400/415/440V	85-484V
200-440V	200/220/240/254/265/380/400/415/440V	170-484V



## NV-H / NV-R (High-performance class) Harmonic Surge Ready

Frame (A)	50	60	63	100	125	125	225	250	250
Model	NV63-HV			NV125-HV		NV125-HEV	NV250-HV		NV250-HEV
Image									
Rated current In (A)	(15) 16 20	(60)	63	(15) 16 20 (30) 32 40 50	125	Adjustable 63-125	125 150 175	250	Adjustable 125-250
Reference ambient temperature 40°C	(30) 32 40 50			(60) 63 (75) 80 100 (*3)		(6.25Astep)	200 225		(12.5A step)
Number of poles	3	3	3	3 4	3 4	3 4	3 4	3 4	3
Phase line (*1)	3φ3W, 1φ3W, 1φ2W	3φ3W, 1φ3W, 1φ2W	3φ3W, 1φ3W, 1φ2W	3φ3W, 1φ3W, 1φ2W 3φ4W	3φ3W, 1φ3W, 1φ2W 3φ4W	3φ3W, 1φ3W, 1φ2W 3φ4W	3φ3W, 1φ3W, 1φ2W 3φ4W	3φ3W, 1φ3W, 1φ2W 3φ4W	3φ3W, 1φ3W, 1φ2W 3φ4W
Rated operational voltage Ue (V) (*2) AC	100-440	100-440	100-440	100-440 200-440	100-440 200-440	100-440	100-440 200-440	100-440 200-440	100-440
High-speed type	Rated current sensitivity (mA)	30,100/200/500 selectable	30,100/200/500 selectable	30,100/200/500 selectable	30,100/200/500 selectable	30,100/200/500 selectable	(30),100/200/500 selectable	30,100/200/500 selectable	30,100/200/500 selectable
	Max. operating time (s)	at IΔn 0.1 at 5IΔn 0.04	0.1 0.04	0.1 0.04	0.1 0.04	0.1 0.04	0.1 0.04	0.1 0.04	0.1 0.04
Time-delay type	Rated current sensitivity (mA)	-	-	-	(100/200/500selectable)	(100/200/500selectable)	(100/200/500selectable)	(100/200/500selectable)	(100/200/500selectable)
	Max. operating time (s) (*4)	-	-	-	(0.45/1.0/2.0selectable)	(0.45/1.0/2.0selectable)	(0.45/1.0/2.0selectable)	(0.45/1.0/2.0selectable)	(0.45/1.0/2.0selectable)
Internal non-operating (s) (or more)	-	-	-	(0.1/0.5/1.0)	(0.1/0.5/1.0)	(0.1/0.5/1.0)	(0.1/0.5/1.0)	(0.1/0.5/1.0)	(0.1/0.5/1.0)
Earth leakage protection characteristic	Type A			Type A		Type A	Type A		Type A
Earth leakage indication system	Mechanical type (button)			Mechanical type (button)		Mechanical type (button)	Mechanical type (button)		Mechanical type (button)
Rated short-circuit breaking capacities (kA)	440V	10/8	10/8	10/8	50/38	50/38	65/65	65/65	65/65
	415V	10/8	10/8	10/8	50/38	50/38	70/70	70/70	70/70
	400V	10/8	10/8	10/8	50/38	50/38	75/75	75/75	75/75
	230V	25/19	25/19	25/19	100/75	100/75	100/100	100/100	100/100
	100V	25/19	25/19	25/19	100/75	100/75	100/100	100/100	100/100
Rated impulse withstand voltage Uimp (kV)	6	6	6	6	6	6	6	6	6
Current	AC	AC	AC	AC	AC	AC	AC	AC	AC
Suitability for isolation	Yes	Yes	Yes	Yes	Yes	Yes	Yes	Yes	Yes
Reverse connection (below 230VAC)	-	-	-	-	-	-	-	-	-
Number of operating cycles	Without current	15,000	15,000	15,000	25,000	25,000	25,000	25,000	25,000
	With current	8,000	8,000	8,000	10,000	10,000	10,000	10,000	10,000
Selectivity category	A	A	A	A	A	A	A	A	A
Rated short time withstand current Icu (kA) at 0.25s	-	-	-	-	-	-	-	-	-
Pollution degree	2	2	2	2	2	2	2	2	2
EMC environment condition (environment A or B)	A	A	A	A	A	A	A	A	A
Overall dimensions (mm)	a	75	75	75	90 120	90 120	105 140	105 140	105 140
	b	130	130	130	130	130	165	165	165
	c	68	68	68	68	68	68	68	68
	d	90	90	90	90	90	92	92	92
Mass of front-face type (kg)	0.75	0.8	0.8	1.1 1.4	1.1 1.4	1.9 2.5	1.8 2.5	1.8 2.5	1.9
Installation and connections	Front connection (F)	●Screw terminal	●Screw terminal	●Screw terminal	●Screw terminal	●Screw terminal	●Screw terminal	●Screw terminal	●Screw terminal
	Solderless (BOX) terminal (SL)	-	-	-	-	-	-	-	-
	Rear (B)	●Round stud	●Round stud	●Round stud	●Bar stud	●Bar stud	●Bar stud	●Bar stud	●Bar stud
Plug-in (PM)	-	-	-	-	-	-	-	-	-
Cassette-type accessories	Alarm switch (AL)	●(*5)	●(*5)	●(*5)	●(*5)	●(*5)	●(*5)	●(*5)	●(*5)
	Auxiliary switch (AX)	●(*5)	●(*5)	●(*5)	●(*5)	●(*5)	●(*5)	●(*5)	●(*5)
	Shunt trip (SHT)	●(*5)	●(*5)	●(*5)	●(*5)	●(*5)	●(*5)	●(*5)	●(*5)
	Undervoltage trip (UVT)	●(*5)	●(*5)	●(*5)	●(*5)	●(*5)	●(*5)	●(*5)	●(*5)
	With lead-wire terminal block (SLT)	●	●	●	●	●	●	●	●
Test button module (TBM)	●(*6)	●(*6)	●(*6)	●(*6)	●(*6)	●(*6)	●(*6)	●(*6)	
External accessories	Enclosure	Closed (S)	-	-	-	-	-	-	-
		Dustproof (I)	-	-	-	-	-	-	-
		Waterproof (W)	-	-	-	-	-	-	-
	Electrical operation device (NFM)	-	-	-	-	-	-	-	-
		Mechanical interlock (MI) (*7)	●	●	●	●	●	●	●
	Lock cover	LC	●	●	●	●	●	●	●
		HL	●	●	●	●	●	●	●
	Handle lock device	HL-S	●	●	●	●	●	●	●
		(F)	●	●	●	●	●	●	●
	External operating handle (V)	●	●	●	●	●	●	●	●
Terminal cover (TC-L, TC-S, TTC, BTC, PTC)	●	●	●	●	●	●(*9)	●	●(*9)	
Rear stud (B-ST)	●	●	●	●	●	●	●	●	
Plug-in (PM)	-	-	-	-	-	-	-	-	
IEC 35mm rail mounting adapters	●	●	●	●	●	●	●	●	
CE marking	Self-declaration	Self-declaration	Self-declaration	Self-declaration	Self-declaration	Self-declaration	Self-declaration	Self-declaration	Self-declaration
UKCA marking	Self-declaration	Self-declaration	Self-declaration	Self-declaration	Self-declaration	Self-declaration	Self-declaration	Self-declaration	Self-declaration
CCC	Certified	Certified	Certified	Certified	Certified	Certified	Certified	Certified	Certified
Marine use approval (NK, LR, ABS, DNV)	-	-	-	-	-	-	-	-	-
Automatic tripping device	Thermal-magnetic	Thermal-magnetic	Thermal-magnetic	Thermal-magnetic	Thermal-magnetic	Electronic (effective value detection)	Thermal-magnetic	Thermal-magnetic	Electronic (effective value detection)
Trip button	Equipped	Equipped	Equipped	Equipped	Equipped	Equipped	Equipped	Equipped	Equipped
Page of Characteristics and dimensions	184			186		190	188		190

Notes: \*1 When using 3-pole earth-leakage circuit breakers for 1-phase 2-wire system, connect cables/busbars to left and right poles, not to center pole. When using 1-phase 3-wire system, connect neutral conductor to center pole of earth leakage circuit breaker.  
 \*2 For time-delay type, the rated voltage is 200-440VAC.  
 \*3 In case of time delay type, rated current is produced with 20 amp. or more.  
 \*4 When the operating time are 0.45, 1.0 and 2.0 seconds, the Earth Leakage circuit breaker operates between 0.15 and 0.45 seconds, between 0.6 and 1.0 seconds and between 1.2 and 2.0 seconds respectively.

\*5 This accessory is cassette type and can be installed by customer. The frame size up to 250A can be closely installed, except for those with UVT.  
 \*6 Standard type is SLT equipped.  
 \*7 No isolation function.  
 \*8 100VAC does not acquire the CCC certification.  
 \*9 For HEV with PAL, it will be an exclusive item.  
 When ordering only the terminal cover, specify the model name with MP at the end.

**NV-H / NV-R (High-performance class) Harmonic Surge Ready**

	400 NV400-HEW	630 NV630-HEW	800 NV800-HEW
			
	Adjustable 200 225 250 300 350 400	Adjustable 300 350 400 500 600 630	Adjustable 400 450 500 600 700 800
	3	3	3
	3φ3W, 1φ3W, 1φ2W	3φ3W, 1φ3W, 1φ2W	3φ3W, 1φ3W, 1φ2W
	100-440	200-440	200-440
	(30), 100/200/500 selectable	-	-
	0.1	-	-
	0.04	-	-
	(100/200/500 selectable)	(100/200/500 selectable)	(100/200/500 selectable)
	(0.45/1.0/2.0)	(0.45/1.0/2.0)	(0.45/1.0/2.0 selectable)
	(0.1/0.5/1.0)	(0.1/0.5/1.0)	(0.1/0.5/1.0)
	Type AC	Type AC	Type AC
	Mechanical type (button)	Mechanical type (button)	Mechanical type (button)
	65/65	65/65	65/65
	70/70	70/70	70/70
	70/70	70/70	70/70
	100/100	100/100	100/100
	100/100	100/100	100/100
	100/100	-	-
	8	8	8
	AC	AC	AC
	Yes	Yes	Yes
	-	-	-
	6,000	6,000	4,000
	1,000	1,000	500
	B	B	B
	5	7.6	9.6
	3	3	3
	A	A	A
	140	140	210
	257	257	275
	103	103	103
	155	155	155
	6.6	7.1	15.3
	8.2	-	-
	●Busbar terminal	●Busbar terminal	●Busbar terminal
	-	-	-
	●Bar stud	●Bar stud	●Bar stud
	●	●	●
	● (*5)	● (*5)	● (*5)
	● (*5)	● (*5)	● (*5)
	● (*5)	● (*5)	● (*5)
	●	●	●
	● (*6)	● (*6)	● (*6)
	-	-	-
	●	●	●
	●	●	●
	● (*7)	● (*7)	● (*7)
	●	●	●
	●	●	●
	●	●	●
	●	●	●
	●	●	●
	●	●	●
	-	-	-
	-	-	-
	Self-declaration	Self-declaration	Self-declaration
	Self-declaration	Self-declaration	Self-declaration
	Certified	Certified	Certified
	-	-	-
	Electronic (effective value detection)	Electronic (effective value detection)	Electronic (effective value detection)
	Equipped	Equipped	Equipped
	194	198	200

- Remarks:
1. Products with rated current parenthesized are produced when an order is placed.
  2. The setting is set to 500mA and delivered when not specifying the rated current sensitivity and the time of time-delay type of operation to 2.0 seconds.
  3. Specify "FP-LT" when using a flush plate product with a lead-wire terminal block.
  4. Specify "P-LT" when selecting plug-in type with lead-wire terminal block.
  5. The circuit breaker has the rated short-circuit breaking capacity specified in the shaded cells.

6. Rated operational voltage	Applicable circuit voltage	Available voltage range
100-440V	100/110/200/220/240/254/265/380/400/415/440V	85-484V
200-440V	200/220/240/254/265/380/400/415/440V	175-484V

## NF-MB

Please specify MB

Frame (A)		30			32			50			100			225						
Model		NF32-SV						NF63-CV			NF63-SV			NF125-SV			NF250-SV			
Rated current In (A)		A	200/220V kW	400/440V kW	A	200/220V kW	400/440V kW	A	200/220V kW	400/440V kW	A	200/220V kW	400/440V kW	A	200/220V kW	400/440V kW	A	200/220V kW	400/440V kW	
Rated motor capacity (kW)		25	5.5	11	32	7.5	15	45	11	22	7.1	1.5	-	100	-	55	225	55	110	
Reference ambient temperature 40°C (45°C for marine use)		16	3.7	7.5				40	-	18.5	5	-	2.2	90	22	45	200	-	-	
		12	-	5.5				32	7.5	15	4	0.75	1.5	71	18.5	37	175	45	90	
		10	2.2	-				25	5.5	11				63	15	30	150	37	75	
		8	-	3.7				16	3.7	7.5				45	11	22	125	30	-	
		7.1	1.5	-				12	-	5.5				(40)	-	18.5				
		5	-	2.2				10	2.2	-				32	7.5	15				
		4	0.75	1.5				8	-	3.7				(25)	5.5	11				
														(16)	3.7	7.5				
														(12.5)	-	5.5				
Number of poles		3						3			3			3			3			
Rated insulation voltage Ui (V)		500						500			500			500			500			
Rated short-circuit breaking capacity (kA)	IEC 60947-2 EN 60947-2 (Icu/Ics)	AC	440V	2.5/2.5	2.5/2.5	2.5/2.5	2.5/2.5	7.5/7.5	7.5/7.5	25/25	36/36									
			415V	2.5/2.5	2.5/2.5	2.5/2.5	2.5/2.5	7.5/7.5	7.5/7.5	30/30	36/36									
			400V	5/5	5/5	5/5	5/5	7.5/7.5	7.5/7.5	30/30	36/36									
			380V	5/5	5/5	5/5	5/5	7.5/7.5	7.5/7.5	30/30	36/36									
			230V	7.5/7.5	7.5/7.5	7.5/7.5	7.5/7.5	15/15	50/50	85/85										
Rated impulse withstand voltage Uimp (kV)		8						8			8			8			8			
Current		AC						AC			AC			AC			AC			
Suitability for isolation		Yes						Yes			Yes			Yes			Yes			
Reverse connection		Available						Available			Available			Available			Available			
Number of operating cycles	Without current	10,000						10,000			15,000			25,000			25,000			
	With current (440VAC)	6,000						6,000			8,000			10,000			10,000			
Selectivity category		A						A			A			A			A			
Pollution degree		3						3			3			3			3			
EMC environment condition (environment A or B)		Not Applicable						Not Applicable			Not Applicable			Not Applicable			Not Applicable			
Overall dimensions (mm)		a	75	75	75	75	90	105												
		b	130	130	130	130	130	165												
		c	68	68	68	68	68	68												
		ca	90	90	90	90	90	92												
		cb	0.65	0.65	0.65	0.65	0.7	1.0	1.6											
Mass of front-face type (kg)		0.65						0.65			0.7			1.0			1.6			
Installation and connections	Front connection (F)	●Screw terminal						●Screw terminal			●Screw terminal			●Screw terminal			●Screw terminal			
	Solderless (BOX) terminal (SL)	-						-			-			-			-			
	Rear (B)	●Round stud						●Round stud			●Round stud			●Bar stud			●Bar stud			
Cassette-type accessories	Plug-in (PM)	●						●			●			●			●			
	Alarm switch (AL)	●(*1)						●(*1)			●(*1)			●(*1)			●(*1)			
	Auxiliary switch (AX)	●(*1)						●(*1)			●(*1)			●(*1)			●(*1)			
	Shunt trip (SHT)	●(*1)						●(*1)			●(*1)			●(*1)			●(*1)			
	Undervoltage trip (UVT)	●(*1)						●(*1)			●(*1)			●(*1)			●(*1)			
	With lead-wire terminal block (SLT)	●						●			●			●			●			
External accessories	Enclosure	Closed (S)	●						●			●			●			●		
		Dustproof (I)	●						●			●			●			●		
		Waterproof (W)	-						-			-			-			-		
	Electrical operation device (NFM)		-						-			●(*3)			●(*3)			-		
		Mechanical interlock (MI) (*2)	●						●			●			●			●		
	Lock cover	Panel mounting	●						●			●			●			●		
		Breaker mounting	●						●			●			●			●		
	Handle lock device	LC	●						●			●			●			●		
		HL	●						●			●			●			●		
	External operating handle	HL-S	●						●			●			●			●		
		(F)	●						●			●			●			●		
	Terminal cover (TC-L, TC-S, TTC, BTC, PTC)	(V)	●						●			●			●			●		
		●						●			●			●			●			
Rear stud (B-ST)		●						●			●			●			●			
Plug-in (PM)		●						●			●			●			●			
IEC 35mm rail mounting adapters		●						●			●			-			-			
CE marking		Self-declaration						Self-declaration			Self-declaration			Self-declaration			TUV approval			
UKCA marking		Self-declaration						Self-declaration			Self-declaration			Self-declaration			Self-declaration			
CCC		Certified						Certified			Certified			Certified			Certified			
Marine use approval (*:Certified) (NK, LR, ABS, DNV)		☆						☆			☆			☆			☆			
Automatic tripping device		Thermal-magnetic						Thermal-magnetic			Thermal-magnetic			Thermal-magnetic			Thermal-magnetic			
Trip button		Equipped						Equipped			Equipped			Equipped			Equipped			
Page of Characteristics and dimensions		146						146			148			152						

Notes: \*1 The operating characteristics are different between AC and DC. This accessory is cassette type and can be installed by customer. The frame size up to 250A can be closely installed, except for those with UVT.  
\*2 No isolation function.  
\*3 Place an order with circuit breaker.

Remarks: 1. The motor circuit breakers do not have an applicable rated motor capacity. Select a motor circuit breaker based on the total load current of the motor.  
2. Products with rating parenthesized are produced when an order is placed.  
3. Specify "P-LT" when selecting plug-in type with lead-wire terminal block.  
4. The circuit breaker has the rated short circuit breaking capacity specified in the shaded cells.  
5. Please refer to "Table 4-17", of Page 79 for details.

## UL 489 Listed Molded Case Circuit Breakers

Frame (A)		50						100						125									
Model		NF50-SMU		NF50-SVFU		NF100-CVFU		NF100-SRU		NF100-HRU		NF125-SVU		NF125-HVU									
Image																							
Rated current In (A) Reference ambient temperature 40°C		0.5 1 (1.5) 2 3 4 5 (6) 7 (8) 10 13 15 20 (25) 30 (35) (40) 50		(0.5) (1) (1.5) (2) (3) 4 5 (6) (7) (8) 10 13 15 20 25 30 (35) 40 50		(3) 5 10 15 20 30 40 50		60 (70) 75 (80) (90) 100		(1) (2) 3 5 10 15 20 (25) 30 40 50 60 (70) 75 (80) (90) 100		(1) (2) 3 5 10 15 20 (25) 30 40 50 60 (70) 75 (80) (90) 100		15 20 30 40 50 60 (70) 75 (80) (90) 100		125		15 20 30 40 50 60 (70) 75 (80) (90) 100		125			
Number of poles		1 2 3		2 3		2 3		2 3		2 3		2 3		2 3		3		3					
Rated short-circuit breaking capacities (kA)	UL 489 CSA C22.2 No.5	Rated voltage	AC (V)	240		240		240		240		480		480		480		600Y/347		600Y/347			
			DC (V)	60		-		-		-		-		-		-		-		-			
		AC	600Y/347V	-		-		-		-		-		-		-		-		18		18	
			480V	-		-		-		-		-		18(10) (*10)		30		30		50		50	
			240V	5 (*11)		10		14		14		35(25) (*10)		50(25) (*10)		50		50		100		100	
	IEC 60947-2 EN 60947-2 (Icu/Ics)	DC	60V	10		-		-		-		-		-		-		-		-			
			Rated insulation voltage Ui (V)	440		440		600		500		500		690		690		690		690			
		AC	690V	-		-		-		-		-		8/4(4/4) (*12)		8/4		10/5(5/5) (*12)		10/5			
			500V	-		-		7.5/4		10/5		18/9(10/5) (*10)		18/9(9/9) (*12)		18/9		25/13(13/13) (*12)		25/13			
			440V	-		7.5/4		10/5		15/8		25/13(15/8) (*10)		30/15		30/15		50/25		50/25			
415V	-		10/5		10/5		15/8		25/13(15/8) (*10)		30/15		30/15		50/25		50/25						
400V	-		10/7.5		10/5		15/8		25/13(15/8) (*10)		30/15		30/15		50/25		50/25						
DC	380V	-		10/5		10/5		-		-		30/15		30/15		50/25		50/25					
	230V	10/7.5		10/7.5		15/8		15/8		35/18(25/13) (*10)		50/25(25/13) (*10)		50/25		50/25		100/50		100/50			
	250V	-		-		-		-		-		-		-		-		-					
	60V	10/7.5		-		-		-		-		-		-		-		-					
Rated impulse withstand voltage Uimp (kV)		6		6		8		8		8		8		8		8		8					
Current (*1)		ACDC compatible		AC		AC		AC		AC		AC		AC		AC		AC					
Suitability for isolation		Yes		Yes		Yes		Yes		Yes		Yes		Yes		Yes		Yes					
Reverse connection		Available		-		Available		Available		Available		Available		Available		Available		Available					
Selectivity category		A		A		A		A		A		A		A		A		A					
Pollution degree		3		3		3		3		3		3		3		3		3					
EMC environment condition (environment A or B)		Not applicable		Not Applicable		Not Applicable		Not applicable		Not applicable		Not Applicable		Not Applicable		Not Applicable		Not Applicable					
Overall dimensions (mm)		a	18	36	54	36	54	50	75	50	75	50	75	90	90	90	90	90	90				
		b	124		120		150		120		120		160		160		160		160				
		c	44 (*7)		68		68		68		74		68		68		68		68				
		ca	70 (*7)		90		90		96		102		90		90		90		90				
		Mass of front-face type (kg)	0.15	0.3	0.45	0.3	0.45	0.55	0.8	0.5	0.75	0.55	0.8	1.0	1.1	1.0	1.1	1.1	1.1				
Installation and connections	Front (F)	Screw terminal (AMP-N)	Page		● (*8)		●		●		●		●		●		●						
		Solderless terminal (SL)	98		-		-		-		-		-		-		-						
		Bar (BAR)	-		-		● (*4)		-		-		-		-		-						
		Power supply solderless load bar (SLBAR)	-		-		● (*4, 5)		● (*5)		● (*5)		● (*5)		● (*5)		● (*5)						
Cassette-type accessories (*2)	Alarm switch (AL)	● (*8)		● (*6)		● (*6)		●		●		● (*6)		● (*6)		● (*6)		● (*6)					
	Auxiliary switch (AX)	● (*8)		● (*6)		● (*6)		●		●		● (*6)		● (*6)		● (*6)		● (*6)					
	Shunt trip (SHT)	● (*8)		● (*6)		● (*6)		●		●		● (*6)		● (*6)		● (*6)		● (*6)					
	Undervoltage trip (UVT)	-		-		● (*6)		●		●		● (*6)		● (*6)		● (*6)		● (*6)					
	With lead-wire terminal block (SLT)	120		-		-		-		-		-		-		-		-					
External accessories (*2)	Mechanical interlock (MI)	136		-		-		-		-		-		-		-		-					
	Handle lock device	(HL)	134		-		-		-		-		-		-		-						
		(HL-S)	-		-		-		-		-		-		-		-						
	External operating handle	(F)	123		-		-		-		-		-		-		-						
		(V)	-		-		-		-		-		-		-		-						
Terminal cover	Large terminal cover (TC-L)	128		-		-		-		-		-		-		-							
	Small terminal cover (TC-S)	-		-		-		-		-		-		-		-							
IEC 35mm rail mounting adapters		143		Standard accessory		Standard accessory		Standard accessory		Standard accessory		Standard accessory		-		-		-					
CE marking		Self-declaration		TÜV approval		TÜV approval		TÜV approval		TÜV approval		TÜV approval		TÜV approval		TÜV approval		TÜV approval					
UKCA marking		Self-declaration		Self-declaration		Self-declaration		Self-declaration		Self-declaration		Self-declaration		Self-declaration		Self-declaration		Self-declaration					
CCC		Certified		Certified		Certified		Certified		Certified		Certified		Certified		Certified		Certified					
Automatic tripping device		Thermal-magnetic		Thermal-magnetic		Thermal-magnetic		Hydraulic-magnetic		Hydraulic-magnetic		Thermal-magnetic		Thermal-magnetic		Thermal-magnetic		Thermal-magnetic					
Trip button		-		Equipped		Equipped		Equipped		Equipped		Equipped		Equipped		Equipped		Equipped					
Page of Characteristics and dimensions		202		204		206		208		208		210		210		210		210					

- Notes: \*1 The trip action characteristics differ between AC and DC for products that are compatible with both AC and DC.  
 \*2 These accessories differ from the general and CE/CCC products in specifications. Please consult us for details.  
 \*3 The standard structure conforms to IP20 (finger protection).  
 \*4 The circuit breakers with busbar terminals have insulation barriers.  
 \*5 Circuit breakers for power supply solderless load screw terminal (SL/AMP-N) are available. In this case, a busbar terminal is not provided on the load side.  
 \*6 This accessory is cassette type and can be installed by customer. The breakers can be closely installed, except for those with UVT and NF50-SVFU model.  
 \*7 Dimensions indicated is as below.

- Remarks: 1. Products with rated current parenthesized are produced when an order is placed.  
 2. The circuit breaker has the rated short-circuit breaking capacity specified in the shaded cells.  
 3. The 3-pole circuit breakers can be used on single-phase circuits.

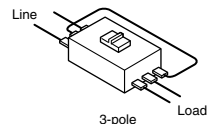



- \*8 Refer to page 203.  
 \*9 No isolation function.  
 \*10 Rated short-circuit breaking capacities parenthesized are applied to below rated current 15A.  
 \*11 Rated short-circuit breaking capacity of rated voltage 120VAC is 10kA.  
 \*12 Breaking capacities in parentheses apply to rated current of 15A and 20A.

US UL Standard 489  
 UL File No.E167691 Body  
 UL File No.E108284 Accessories

Canada CSA Standard  
 C22.2 No.5

## UL 489 Listed Molded Case Circuit Breakers

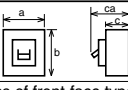
Frame (A)		250						
Model		NF250-CVU		NF250-SVU		NF250-HVU		
Image								
Rated current In (A) Reference ambient temperature 40°C		125 150 175 200 225	250	125 150 175 200 225	250	125 150 175 200 225	250	
Number of poles		3	3	3	3	3	3	
Rated short-circuit breaking capacities (kA)	UL 489 CSA C22.2 No.5	Rated voltage AC (V) DC (V)	240	240	480	480	600Y/347 600Y/347	
		AC	600Y/347V	-	-	-	-	18
			480V	-	-	35	35	50
			240V	35	35	65	65	100
	DC	60V	-	-	-	-	-	
	IEC 60947-2 EN 60947-2 (Icu/Ics)	Rated insulation voltage Ui (V)	600	600	690	690	690	690
		AC	690V	-	-	8/4	8/4	10/5
			500V	10/8	10/8	25/13	25/13	36/18
			440V	15/12	15/12	36/18	36/18	50/25
			415V	25/19	25/19	36/18	36/18	50/25
400V			25/19	25/19	36/18	36/18	50/25	
380V			25/19	25/19	36/18	36/18	50/25	
230V	36/27		36/27	65/33	65/33	100/50		
DC	250V	-	-	-	-	-		
60V	-	-	-	-	-	-		
Rated impulse withstand voltage Uimp (kV)		8	8	8	8	8	8	
Current (*1)		AC	AC	AC	AC	AC	AC	
Suitability for isolation		Yes	Yes	Yes	Yes	Yes	Yes	
Reverse connection		Available	Available	Available	Available	Available	Available	
Selectivity category		A	A	A	A	A	A	
Pollution degree		3	3	3	3	3	3	
EMC environment condition (environment A or B)		Not applicable	Not applicable	Not Applicable	Not Applicable	Not Applicable	Not Applicable	
Overall dimensions (mm)		a	105	105	105	105	105	
		b	185	185	185	185	185	
		c	68	68	68	68	68	
		ca	92	92	92	92	92	
		ca	92	92	92	92	92	
Mass of front-face type (kg)		1.6	1.6	1.6	1.6	1.6	1.6	
Installation and connections	Front (F)	Screw terminal (AMP-N)	Page	●	●	●	●	
	Solderless terminal (SL)	98	●	●	●	●	●	
Cassette-type accessories (*2)	Bar (BAR)	●	●	●	●	●	●	
	Power supply solderless load bar (SL/BAR)	●(*6)	●(*6)	●(*6)	●(*6)	●(*6)	●(*6)	
	Alarm switch (AL)	●(*5)	●(*5)	●(*5)	●(*5)	●(*5)	●(*5)	
	Auxiliary switch (AX)	●(*5)	●(*5)	●(*5)	●(*5)	●(*5)	●(*5)	
	Shunt trip (SHT)	●(*5)	●(*5)	●(*5)	●(*5)	●(*5)	●(*5)	
	Undervoltage trip (UVT)	●(*5)	●(*5)	●(*5)	●(*5)	●(*5)	●(*5)	
	With lead-wire terminal block (SLT)	120	●	●	●	●	●	
	Mechanical interlock (MI)	136	-	-	-	-	-	
	External accessories (*2)	Handle lock device (HL)	134	●	●	●	●	●
		(HL-S)	●	●	●	●	●	
External operating handle		(F)	123	●	●	●	●	
		(V)	●	●	●	●	●	
		(C)	127	●(*4)	●(*4)	●(*4)	●(*4)	
Terminal cover		Large terminal cover (TC-L)	128	●	●	●	●	
	Small terminal cover (TC-S)	128	●(*3)	●(*3)	●(*3)	●(*3)		
	IEC 35mm rail mounting adapters	143	-	-	-	-	-	
CE marking		TÜV approval	TÜV approval	TÜV approval	TÜV approval	TÜV approval	TÜV approval	
UKCA marking		Self-declaration	Self-declaration	Self-declaration	Self-declaration	Self-declaration	Self-declaration	
CCC		Certified	Certified	Certified	Certified	Certified	Certified	
Automatic tripping device		Thermal-magnetic	Thermal-magnetic	Thermal-magnetic	Thermal-magnetic	Thermal-magnetic	Thermal-magnetic	
Trip button		Equipped	Equipped	Equipped	Equipped	Equipped	Equipped	
Page of Characteristics and dimensions		212		212		212		



- Notes: \*1 The operating characteristics are different between AC and DC.  
 \*2 These accessories differ from the general products in specifications. Please consult us for details.  
 \*3 The standard structure conforms to IP20 (finger protection).  
 \*4 No isolation function.  
 \*5 This accessory is cassette type and can be installed by customer. The breakers can be closely installed, except for those with UVT.  
 \*6 Circuit breakers for power supply solderless load screw terminal (SL/AMP-N) are available. In this case, a busbar terminal is not provided on the load side.

- Remarks: 1. Products with rated current parenthesized are produced when an order is placed.  
 2. The circuit breaker has the rated short-circuit breaking capacity specified in the shaded cells.  
 3. The 3-pole circuit breakers can be used on single-phase circuits.

US UL Standard 489  
 UL File No.E167691 Body  
 UL File No.E108284 Accessories

Canada CSA Standard  
 C22.2 No.5

## UL 489 Listed Molded Case Circuit Breakers

Frame (A)		400		630	
Model		NF400-SWU		NF400-HWU	
Image					
Rated current In (A) Reference ambient temperature 40°C		250 300 350 400		250 300 350 400	
Number of poles		3		3	
Rated short-circuit breaking capacities (kA)	UL 489 CSA C22.2 No.5	Rated voltage	AC (V)	600Y/347	
			DC (V)	-	
		AC	600Y/347V	20	
			480V	35	
	240V		65		
	IEC 60947-2 EN 60947-2 (Icu/Ics)	Rated insulation voltage Ui (V)	AC	690	
			DC	-	
		AC	690V	10/10(5/5)(*4)	
			500V	30/30(25/25)(*4)	
			440V	42/42(36/36)(*4)	
415V			45/45(36/36)(*4)		
DC	400V	45/45(36/36)(*4)			
	380V	50/50(42/42)(*4)			
Rated impulse withstand voltage Uimp (kV)		8		8	
Current		AC		AC	
Suitability for isolation		Yes		Yes	
Reverse connection		Available		Available	
Selectivity category		A		A	
Pollution degree		3		3	
EMC environment condition (environment A or B)		Not Applicable		Not Applicable	
Overall dimensions (mm)		a	140		
		b	257		
		c	103		
		ca	155		
		Mass of front-face type (kg)	5.7		
Installation and connections	Front (F)	Screw terminal (AMP-N)	Page		
		Solderless terminal (SL)	●		
		Bar (BAR)	●(*5)		
		Power supply solderless load bar (SLBAR)	●(*5)		
Cassette-type accessories	Alarm switch (AL)	●(*3)			
	Auxiliary switch (AX)	●(*3)			
	Shunt trip (SHT)	●(*3)			
	Undervoltage trip (UVT)	●			
	With lead-wire terminal block (SLT)	120			
External accessories	Mechanical interlock (MI)	●(*1)(*2)			
	Handle lock device (HL)	(HL)	●(*6)		
		(HL-S)	-		
	External operating handle	(F)	●		
		(V)	●		
		(C)	●(*1)		
	Terminal cover	Large terminal cover (TC-L)	●		
Small terminal cover (TC-S)		-			
IEC 35mm rail mounting adapters	143				
CE marking		TÜV approval		TÜV approval	
UKCA marking		Self-declaration		Self-declaration	
CCC		Certified		Certified	
Automatic tripping device		Thermal-magnetic		Thermal-magnetic	
Trip button		Equipped		Equipped	
Page of Characteristics and dimensions		214		214	

- Notes: \*1 No isolation function.  
 \*2 Not acquire the TÜV certification.  
 \*3 This accessory is cassette type and can be installed by customer. The frame size up to 250A can be closely installed, except for those with UVT.  
 \*4 The values in parentheses apply to the circuit breakers with solderless terminals.  
 \*5 The circuit breakers with busbar terminals have insulation barriers.  
 \*6 Please consult us. (Models which are not UL or TUV certified but can be locked in the ON and OFF positions are available.)  
 \*7 Not available for 630A.

- Remarks: 1. The circuit breaker has the rated short-circuit breaking capacity specified in the shaded cells.  
 2. The 3-pole circuit breakers can be used on single-phase circuits.

US UL Standard 489  
UL File No.E167691 Body  
UL File No.E108284 Accessories

Canada CSA Standard  
C22.2 No.5

## UL 489 Listed Earth Leakage Circuit Breakers (Harmonic Surge Ready)

Frame (A)		50		100		125							
Model		NV50-SVFU		NV100-CVFU		NV100-SRU		NV100-HRU		NV125-SVU		NV125-HVU	
Image													
Rated current I <sub>n</sub> (A)		(5) (10) 15 20 30 40 50		60 (70) 75 (80) (90) 100		5 10 15 20 (25) 30 40 50		5 10 15 20 (25) 30 40 50 60 (70) 75 (80) (90) 100		15 20 30 (40) 50 60 75 100		125 50 60 75 100	
Reference ambient temperature 40°C													
Number of poles		2 3		3		2 3		3		3 3		3 3	
Phase line (*1)		1φ2W 3φ3W, 1φ2W		3φ3W, 1φ2W		1φ2W 3φ3W, 1φ2W		3φ3W, 1φ2W		3φ3W, 1φ2W 3φ3W, 1φ2W		3φ3W, 1φ2W	
Rated operational voltage AC V		UL 489 IEC 60947-2 EN 60947-2		120-240		120-240		120-240		120-240-480		120-480	
Earth leakage protection characteristic		Type A		Type A		Type A		Type A		Type A		Type A	
Earth leakage indication system		Display window		Mechanical type (button)		Mechanical type (button)		Mechanical type (button)		Mechanical type (button)		Mechanical type (button)	
Rated short-circuit breaking capacities (kA)		480V 240V 120V		480V 240V 120V		480V 240V 120V		480V 240V 120V		480V 240V 120V		480V 240V 120V	
UL 489 CSA C22.2 No.5		AC		AC		AC		AC		AC		AC	
IEC 60947-2 EN 60947-2 (Icu/Ics)		AC		AC		AC		AC		AC		AC	
Rated impulse withstand voltage U <sub>imp</sub> (kV)		4 6		6		8		8		6 6		6 6	
Suitability for isolation		Yes		Yes		Yes		Yes		Yes Yes		Yes Yes	
Reverse connection (below 240VAC)		-		Available		-		Available		Available		Available	
Selectivity category		A		A		A		A		A A		A A	
Pollution degree		2		2		2		2		2 2		2 2	
EMC environment condition (environment A or B)		A		A		A		A		A A		A A	
Overall dimensions (mm)		a b c ca		a b c ca		a b c ca		a b c ca		a b c ca		a b c ca	
Mass of front-face type (kg)		0.4 0.5		0.9		0.55 0.85		0.95		1.2 1.2		1.2 1.2	
Installation and connections		Screw terminal (AMP-N) Solderless terminal (SL) Bar (BAR) Power supply solderless load bar (SL/BA)		Screw terminal (AMP-N) Solderless terminal (SL) Bar (BAR) Power supply solderless load bar (SL/BA)		Screw terminal (AMP-N) Solderless terminal (SL) Bar (BAR) Power supply solderless load bar (SL/BA)		Screw terminal (AMP-N) Solderless terminal (SL) Bar (BAR) Power supply solderless load bar (SL/BA)		Screw terminal (AMP-N) Solderless terminal (SL) Bar (BAR) Power supply solderless load bar (SL/BA)		Screw terminal (AMP-N) Solderless terminal (SL) Bar (BAR) Power supply solderless load bar (SL/BA)	
Cassette-type accessories (*2)		Alarm switch (AL) Auxiliary switch (AX) Shunt trip (SHT) Undervoltage trip (UVT) With lead-wire terminal block (SLT) Test button module (TBM)		Alarm switch (AL) Auxiliary switch (AX) Shunt trip (SHT) Undervoltage trip (UVT) With lead-wire terminal block (SLT) Test button module (TBM)		Alarm switch (AL) Auxiliary switch (AX) Shunt trip (SHT) Undervoltage trip (UVT) With lead-wire terminal block (SLT) Test button module (TBM)		Alarm switch (AL) Auxiliary switch (AX) Shunt trip (SHT) Undervoltage trip (UVT) With lead-wire terminal block (SLT) Test button module (TBM)		Alarm switch (AL) Auxiliary switch (AX) Shunt trip (SHT) Undervoltage trip (UVT) With lead-wire terminal block (SLT) Test button module (TBM)		Alarm switch (AL) Auxiliary switch (AX) Shunt trip (SHT) Undervoltage trip (UVT) With lead-wire terminal block (SLT) Test button module (TBM)	
External accessories (*2)		Mechanical interlock (MI) Handle lock device (HL) External operating handle (F) Terminal cover (V) IEC 35mm rail mounting adapters		Mechanical interlock (MI) Handle lock device (HL) External operating handle (F) Terminal cover (V) IEC 35mm rail mounting adapters		Mechanical interlock (MI) Handle lock device (HL) External operating handle (F) Terminal cover (V) IEC 35mm rail mounting adapters		Mechanical interlock (MI) Handle lock device (HL) External operating handle (F) Terminal cover (V) IEC 35mm rail mounting adapters		Mechanical interlock (MI) Handle lock device (HL) External operating handle (F) Terminal cover (V) IEC 35mm rail mounting adapters		Mechanical interlock (MI) Handle lock device (HL) External operating handle (F) Terminal cover (V) IEC 35mm rail mounting adapters	
CE marking		TUV approval		TUV approval		TUV approval		TUV approval		TUV approval		TUV approval	
UKCA marking		Self-declaration		Self-declaration		Self-declaration		Self-declaration		Self-declaration		Self-declaration	
CCC		Certified		Certified		Certified		Certified		Certified		Certified	
Automatic tripping device		Thermal-magnetic		Thermal-magnetic		Hydraulic-magnetic		Hydraulic-magnetic		Thermal-magnetic		Thermal-magnetic	
Trip button		Equipped		Equipped		Equipped		Equipped		Equipped		Equipped	
Page of Characteristics and dimensions		204		206		208		208		210		210	

- Notes:
- \*1 When using 3-pole earth-leakage circuit breakers for 1-phase 2-wire system, connect cables/busbars to left and right poles, not to center pole.
  - \*2 These are different from general models in specifications. Consult us for the details.
  - \*3 The standard structure conforms to IP20 (finger protection).
  - \*4 The maximum operating time is 0.1 according to UL 1053.
  - \*5 The circuit breakers with busbar terminals have insulation barriers.
  - \*6 Circuit breakers for power supply solderless load screw terminal (SL/AMP-N) are available. In this case, a bar terminal is not provided on the load side.
  - \*7 Circuit breakers for 100VAC do not have obtained CCC certificate.
  - \*8 This accessory is cassette type and can be installed by customer. The breakers can be closely installed, except for those with UVT and NV50-SVFU model.
  - \*9 Standard type is SLT equipped.
  - \*10 Rated short-circuit breaking capacities parenthesized are applied to below rated current 15A.
  - \*11 No isolation function.

- Remarks:
1. Products with rated current parenthesized are produced when an order is placed.
  - 2.

Rated operational voltage	Applicable circuit voltage	Available voltage range
120-240V (UL)	120/240V	66-264V
120-240-480V (UL)	120/240/480V	66-528V
240V (UL)	240V	132-264V
100-230V (IEC)	100/110/200/220/230V	85-253V
100-240V (IEC)	100/110/200/220/230/240V	85-264V
100-230V-440V (IEC)	100/110/200/220/230/240/254/265/380/400/415/440V	85-484V
230-400-440V (IEC)	230/240/254/265/380/400/415/440V	195-484V

US UL Standard 489  
UL File No.E167691 Body  
UL File No.E108284 Accessories

Canada CSA Standard  
C22.2 No.5

**UL 489 Listed Earth Leakage Circuit Breakers (Harmonic Surge Ready)**

Frame (A)		250					
Model		NV250-CVU		NV250-SVU		NV250-HVU	
Image							
Rated current I <sub>n</sub> (A) Reference ambient temperature 40°C		125 150 175 200 225		250		125 150 175 200 225 250	
Number of poles		3		3		3	
Phase line (*1)		3φ3W, 1φ2W		3φ3W, 1φ2W		3φ3W, 1φ2W	
Rated operational voltage AC V		120-240		120-240		120-480	
UL 489 IEC 60947-2 EN 60947-2		100-440		100-440		100-440	
High-speed type	Rated current sensitivity I <sub>Δn</sub> mA	30 50 100/300/500 selectable		30 50 100/300/500 selectable		30 50 100/200/500 selectable	
	Pickup current, UL 1053 Max. operating time (s) at 5I <sub>Δn</sub> (*4)	75% of I <sub>Δn</sub> 0.04		75% of I <sub>Δn</sub> 0.04		75% of I <sub>Δn</sub> 0.04	
Earth leakage protection characteristic		Type A		Type A		Type A	
Earth leakage indication system		Mechanical type (button)		Mechanical type (button)		Mechanical type (button)	
Rated short-circuit breaking capacities (kA)	UL 489 CSA C22.2 No.5	AC	480V	-	-	35	35
			240V	35	35	65	65
			120V	35	35	65	65
	IEC 60947-2 EN 60947-2 (Icu/Ics)	AC	440V	15/12	15/12	36/18	36/18
			400V	25/19	25/19	36/18	36/18
			230V	36/27	36/27	65/33	65/33
			100V	36/27	36/27	65/33	65/33
Rated impulse withstand voltage U <sub>imp</sub> (kV)		6		6		6	
Suitability for isolation		Yes		Yes		Yes	
Reverse connection (below 240VAC)		Available		Available		Available	
Selectivity category		A		A		A	
Pollution degree		2		2		2	
EMC environment condition (environment A or B)		A		A		A	
Overall dimensions (mm)		a	105	105	105	105	105
		b	185	185	185	185	185
		c	68	68	68	68	68
		ca	92	92	92	92	92
		Mass of front-face type (kg)	1.2		1.2		1.8
Installation and connections	Front (F)	Screw terminal (AMP-N)	Page	●	●	●	●
		Solderless terminal (SL)		●	●	●	●
		Bar (BAR)	98	●	●	●	●
		Power supply solderless lead bar (SLBAR)		●(*6)	●(*6)	●(*6)	●(*6)
Cassette-type accessories (*2)	Alarm switch (AL)	115	●(*8)	●(*8)	●(*8)	●(*8)	
	Auxiliary switch (AX)		●(*8)	●(*8)	●(*8)	●(*8)	
	Shunt trip (SHT)		●(*8)	●(*8)	●(*8)	●(*8)	
	Undervoltage trip (UVT)		●(*8)	●(*8)	●(*8)	●(*8)	
	With lead-wire terminal block (SLT)	120	●	●	●	●	
	Test button module (TBM)	121	●(*9)	●(*9)	●(*9)	●(*9)	
External accessories (*2)	Mechanical interlock (MI)	136	-	-	-	-	
	Handle lock device	(HL)	134	●	●	●	
		(HL-S)		●	●	●	
	External operating handle	(F)	123	●	●	●	
		(V)		●	●	●	
		(C)	127	●(*11)	●(*11)	●(*11)	
Terminal cover	Large terminal cover (TC-L) Small terminal cover (TC-S)	128	●(*3)	●(*3)	●(*3)		
IEC 35mm rail mounting adapters		143	Standard accessory	Standard accessory	-	-	
CE marking		TUV approval		TUV approval		TUV approval	
UKCA marking		Self-declaration		Self-declaration		Self-declaration	
CCC		Certified		Certified		Certified	
Automatic tripping device		Thermal-magnetic		Thermal-magnetic		Thermal-magnetic	
Trip button		Equipped		Equipped		Equipped	
Page of Characteristics and dimensions		212		212		212	

- Notes: \*1 When using 3-pole earth-leakage circuit breakers for 1-phase 2-wire system, connect cables/busbars to left and right poles, not to center pole.  
 \*2 These are different from general models in specifications. Consult us for the details.  
 \*3 The standard structure conforms to IP20 (finger protection).  
 \*4 The maximum operating time is 0.1 according to UL 1053.  
 \*5 The circuit breakers with busbar terminals have insulation barriers.  
 \*6 Circuit breakers for power supply solderless load screw terminal (SL/AMP-N) are available. In this case, a bar terminal is not provided on the load side.  
 \*7 Circuit breakers for 100VAC do not have obtained CCC certificate.  
 \*8 This accessory is cassette type and can be installed by customer. The breakers can be closely installed, except for those with UVT and NV50-SVFU model.  
 \*9 Standard type is SLT equipped.  
 \*10 Rated short-circuit breaking capacities parenthesized are applied to below rated current 15A.  
 \*11 No isolation function.

Remarks: 1. Products with rated current parenthesized are produced when an order is placed.

Rated operational voltage	Applicable circuit voltage	Available voltage range
120-240V (UL)	120/240V	66-264V
120-240-480V (UL)	120/240/480V	66-528V
240V (UL)	240V	132-264V
100-230V (IEC)	100/110/200/220/230V	85-253V
100-240V (IEC)	100/110/200/220/230/240V	85-264V
100-230-400-440V (IEC) 100-440V (IEC)	100/110/200/220/ 230/240/254/265/ 380/400/415/440V	85-484V
230-400-440V (IEC)	230/240/254/265/ 380/400/415/440V	195-484V

US UL Standard 489  
UL File No.E167691 Body  
UL File No.E108284 Accessories

Canada CSA Standard  
C22.2 No.5

## UL 1077 Recognized Circuit Breakers for Control boards

Frame (A)		30		50		100		30		50		100					
Model		NF30-FAU		NF50-FAU		NF50-FHU		NF100-FHU		NV30-FAU		NV50-FAU		NV50-FHU		NV100-FHU	
Image																	
Phase line (*1)		-		-		-		-		1φ2W		3φ3W 1φ2W		1φ2W		3φ3W 1φ3W 1φ2W	
Number of poles		2		3		2		3		2		3		2		3	
Rated current I <sub>n</sub> (A)		5		10		15		20		30		40		50		60	
Reference ambient temperature 40°C		5		10		15		20		30		40		50		60	
Motor protection rated current (*12)		5		10		15		20		30		40		50		60	
High-speed type		-		-		-		-		-		-		-		-	
Rated current sensitivity I <sub>Δn</sub> (mA)		-		-		-		-		30		30		30		50	
Pickup current sensitivity UL1053		-		-		-		-		75% of I <sub>Δn</sub>		75% of I <sub>Δn</sub>		75% of I <sub>Δn</sub>		75% of I <sub>Δn</sub>	
Max. operating time(s) at 5I <sub>Δn</sub> (*9)		-		-		-		-		0.04		0.04		0.04		0.04	
Earth leakage protection characteristic		-		-		-		-		Type AC		Type AC		Type AC		Type AC	
Earth-leakage indication system		-		-		-		-		Mechanical type(button)		Mechanical type(button)		Mechanical type(button)		Mechanical type(button)	
Rated short-circuit breaking capacities (kA)		240		240		240		240		240		240		240		240	
UL 1077		AC(V)		240		240		240		240		240		240		240	
CSA C22.2 No.235		DC(V)		60		60		60		60		60		60		60	
		AC		240V		2.5(*2)		2.5(*2)		5		5		2.5(*2)		2.5(*2)	
		DC		60V		1.5		1.5		5		5		2.5(*2)		2.5(*2)	
		Rated insulation voltage (V)		250		250		500		500		230		230		230	
IEC 60947-2		400 V		-		-		1.5/1		-		-		-		-	
EN 60947-2 (Icu/Ics)		AC		230 V		2.5/1(*3)		2.5/1(*3)		5/2		5/2		2.5/1(*3)		2.5/1(*3)	
		DC		60 V		1.5/1(*13)		1.5/1(*13)		-		-		-		-	
Rated impulse withstand voltage U <sub>imp</sub> (kV)		2.5		2.5		4		4		2.5		2.5		4		4	
Current		AC/DC compatible		AC/DC compatible		AC		AC		AC		AC		AC		AC	
Suitability for isolation		-		-		-		-		-		-		-		-	
Reverse connection		-		-		-		-		-		-		-		-	
EMC environment condition (environment A or B)		Not applicable		Not applicable		Not applicable		Not applicable		A		A		A		A	
Selectivity category		A		A		A		A		A		A		A		A	
Pollution degree		2		2		2		2		2		2		2		2	
Overall dimensions (mm)		a		40		60		40		60		40		60		50	
		b		72		72		96		97.5		72		72		96	
		c		57		57		60		60		57		57		60	
		ca		73.5		73.5		76		76		73.5		73.5		76	
Mass of front-face type (kg)		0.14		0.2		0.16		0.22		0.25		0.37		0.51		0.16	
Adapter for IEC 35mm rail		Equipped		Equipped		Equipped		Equipped		Equipped		Equipped		Equipped		Equipped	
Mounting screws		●(*4)		●(*4)		●(*4)		●(*4)		●(*4)		●(*4)		●(*4)		●(*4)	
Front-plate attachment		●(*5)		●(*5)		-		-		●(*5)		●(*5)		-		-	
Connection		Page		98		●		●		●		●		●		●	
Internal accessories		Alarm switch (AL)		●		●		●(*7)		●(*8)		●		●		●(*7)	
		Auxiliary switch (AX)		112		●		●		●(*8)		●		●		●(*8)	
		Shunt trip (SHT)		●		●		●(*7)		●(*8)		-		-		-	
		With lead-wire terminal block (SLT)		120		●		●		●		●		●		●	
External accessories		Lock cover (LC)		134		●(*10)		●(*10)		●(*11)		●(*11)		●(*10)		●(*11)	
		Handle lock device (HL)		●(*10)		●(*10)		●(*10)		●(*11)		●(*11)		●(*10)		●(*11)	
		Large terminal cover (TC-L)		-		-		●(*11)		●(*11)		-		-		●	
		Small terminal cover (TC-S)		128		●		●		-		-		●		●	
		Rear terminal cover (RTC)		●		●		-		-		-		-		-	
CE marking		TÜV approval		TÜV approval		TÜV approval		TÜV approval		TÜV approval		TÜV approval		TÜV approval		TÜV approval	
UKCA marking		Self-declaration		Self-declaration		Self-declaration		Self-declaration		Self-declaration		Self-declaration		Self-declaration		Self-declaration	
CCC		Certified		Certified		Certified		Certified		Certified		Certified		Certified		Certified	
Automatic tripping device		Thermal		Thermal		Hydraulic-magnetic		Hydraulic-magnetic		Thermal		Thermal		Hydraulic-magnetic		Hydraulic-magnetic	
Trip button		-(*6)		-(*6)		-(*6)		-(*6)		-		-		-		-	
Page of Characteristics and dimensions		218		218		220		220		218		218		220		220	

Notes: \*1 If using a 3-pole earth-leakage circuit breaker for a 1-phase 2-wire system, connect the left and right poles, not the center pole.  
 When using a 1-phase 3-wire system, connect the neutral wire to the center pole of the earth-leakage circuit breaker. (1φ3W cannot be used with UL.)  
 \*2 Rated short-circuit breaking capacity of rated current 5A is 1.5kA.  
 \*3 Rated short-circuit breaking capacity of rated current 5A is 1.5/1kA.  
 \*4 Mounting screws are not attached.  
 \*5 Front-plate attachment is possible without nut bolting from back. (Mounting screws are not attached.) In this case a terminal screw can be bolted from the back of molded-case circuit breaker.  
 \*6 When alarm switch (AL) is installed, this product has a trip-button. (When Shunt trip device (SHT) + alarm switch (AL) is installed, this product don't have a trip-button.)  
 \*7 Lead wires are normally extended laterally.  
 Grooves are provided standard on the face of the breaker, allowing the extension of the lead wires along them.  
 \*8 Lead wires are usually extended load side.  
 \*9 In case of UL1053, operating time is 0.1s.  
 \*10 It is recognition of UL (cURus) CSA. It is not recognition of CCC, TÜV, UKCA.  
 \*11 Not acquire UL (cURus), CCC, TÜV, UKCA.  
 \*12 Only sensitivity current 30mA or 50mA can be manufactured at Motor protection rated currents.  
 \*13 For 3-pole product, connect cables/busbars to any two terminals.

## MDU Breakers

Frame (A)		250				400				800									
Model		NF250-SEV with MDU   NF250-HEV with MDU				NF400-SEV with MDU   NF400-HEW with MDU				NF800-SEV with MDU		NF800-HEW with MDU		NF800-SEW with MDU		NF800-HEW with MDU			
Image																			
Rated current In (A) Reference ambient temperature 40°C		Adjustable 125-250 (12.5A step)				Adjustable 200 225 250 300 350 400				Adjustable 300 350 400 500 600 630				Adjustable 400 450 500 600 700 800					
Number of poles		3		4		3		4		3		4		3		4			
Phase line		3-pole type: 3φ3W 4-pole type: 3φ4W (3-pole type can be used as a 1φ2W unit.)																	
Rated insulation voltage Ui (V)		690																	
Rated short-circuit breaking capacities (kA)	IEC 60947-2 EN 60947-2 (Icu/Ics)	AC	690V	8/8	10/8	10/10	10/10	10/10	10/10	15/15	10/10	15/15	10/10	15/15	10/10	15/15	10/10	15/15	
			500V	18/18	30/23	30/30	50/50	30/30	50/50	30/30	50/50	30/30	50/50	30/30	50/50	30/30	50/50	30/30	50/50
			440V	36/36	50/50	42/42	65/65	42/42	65/65	42/42	65/65	42/42	65/65	42/42	65/65	42/42	65/65	42/42	65/65
			415V	36/36	70/70	50/50	70/70	50/50	70/70	50/50	70/70	50/50	70/70	50/50	70/70	50/50	70/70	50/50	70/70
			400V	36/36	75/75	50/50	70/70	50/50	70/70	50/50	70/70	50/50	70/70	50/50	70/70	50/50	70/70	50/50	70/70
	GB/T 14048.2 (Icu/Ics)	AC	380V	36/36	75/75	50/50	70/70	50/50	70/70	50/50	70/70	50/50	70/70	50/50	70/70	50/50	70/70	50/50	70/70
			230V	85/85	100/100	85/85	100/100	85/85	100/100	85/85	100/100	85/85	100/100	85/85	100/100	85/85	100/100	85/85	100/100
			200V	85/85	100/100	85/85	100/100	85/85	100/100	85/85	100/100	85/85	100/100	85/85	100/100	85/85	100/100	85/85	100/100
			415 V	36/36	70/70	50/50	70/70	50/50	70/70	50/50	70/70	50/50	70/70	50/50	70/70	50/50	70/70	50/50	70/70
			400 V	36/36	75/75	50/50	70/70	50/50	70/70	50/50	70/70	50/50	70/70	50/50	70/70	50/50	70/70	50/50	70/70
380 V	36/36	75/75	50/50	70/70	50/50	70/70	50/50	70/70	50/50	70/70	50/50	70/70	50/50	70/70	50/50	70/70	50/50	70/70	
230 V	85/85	100/100	85/85	100/100	85/85	100/100	85/85	100/100	85/85	100/100	85/85	100/100	85/85	100/100	85/85	100/100	85/85	100/100	
Rated impulse withstand voltage Uimp (kV)		8				8				8									
Current		AC				AC				AC									
Suitability for isolation		Yes				Yes				Yes									
Reverse connection		-				-				-									
Number of operating cycles	Without current	25,000				6,000				6,000				4,000					
	With current(440VAC)	10,000				1,000				1,000				500					
Selectivity category		A				B				B									
Rated short-time resistant current Icw kA (0.25s)		-				5				7.6				9.6					
Pollution degree		3				3				3									
EMC environment condition (environment A or B)		A				A				A									
Oval dimensions (mm)	a	105	140	105	140	140	185	140	185	210	280	210	280	210	280	210	280		
	b	165				257				275									
	c	68				103				103									
	ca	92				155				155									
Mass of front-face type (Breaker mounting) (kg)		1.8	2.3	1.8	2.3	6.2	8	6.2	8	10.7	13.8	10.7	13.8	11.1	14.4	11.1	14.4		
MDU mounting method (*1)		External mounting, panel mounting, breaker mounting, breaker mounting unit separate installation																	
Installation and connections	Front	(F)	Page	●	●	●	●	Busbar terminal											
	Rear (*2)	(B)	98	●	●	●	●	Bar stud											
Cassette-type accessories (*4)	Alarm switch (AL)	115	●(*3)	●	●(*3)	●	●(*3)	●(*3)											
	Auxiliary switch (AX)	115	●(*3)	●	●(*3)	●	●(*3)	●(*3)											
	Shunt trip (SHT)	115	●(*3)	●	●(*3)	●	●(*3)	●(*3)											
	Undervoltage trip (UVT)	115	●	●	●	●	●												
	MDU transmission AL, AX, AL + AX	115	●	●	●	●	●												
	With lead-wire terminal block (SLT)	120	●	●	●	●	●												
Alarm contact [Pre-alarm (PAL) output (*5) Cause of fault (TI)]	122	●	● PAL 1a	●	● PAL 1a	●	● PAL 1a, OAL 1a	●	● PAL 1a	●	● PAL 1a, OAL 1a	●	● PAL 1a, OAL 1a	●	● PAL 1a, OAL 1a	●	● PAL 1a, OAL 1a		
External accessories	Electrical operation device (*6) (NFM)	140	● Can be installed only in the case of panel mounting.																
	Mechanical interlock (MI) (*7)	136	● Can be installed only in the case of panel mounting.																
	Handle lock device	LC	134	●															
		HL	134	●															
		HL-S	134	●															
	External operating handle	(F)	123	● Can be installed only in the case of panel mounting.															
		(V)	123	● Can be installed only in the case of panel mounting.															
		(S) (*7)	123	● Can be installed only in the case of panel mounting.															
		(C) (*7)	123	● Can be installed only in the case of panel mounting.															
	Terminal cover	TC-L	128	●(*9)	●(*10)	●(*9)	●(*10)	● Can be installed only in the case of panel mounting, breaker mounting and breaker mounting unit separate installation (except NF400-HEW with MDU)											
TC-S		128	●(*9)	●(*10)	●(*9)	●(*10)	-												
TTC		128	●(*9)	●(*11)	●(*9)	●(*11)	●(*10)												
BTC		128	●(*9)	●(*10)	●(*9)	●(*10)	● Can be installed only on the power supply side in the case of external mounting.												
Rear stud (B-ST)	100	●	●	●	●	-													
CE marking	Self-declaration				Self-declaration				Self-declaration										
UKCA marking	Self-declaration				Self-declaration				Self-declaration										
CCC	Certified				Certified				Certified										
Automatic tripping device	Electronic (effective value detection)				Electronic (effective value detection)				Electronic (effective value detection)										
Trip button	Equipped				Equipped				Equipped										
Page of Characteristics and dimensions	222				224				226										

Notes: \*1 When the panel mounting is specified, the breaker comes with panel fittings and mounting screws, and the 2m long connecting cable (standard) is supplied. (The connecting cable length, 0.5m, 3m, 5m or 10m, can be specified.) When the breaker mounting separate unit is specified, the 2m long connecting cable (standard) is supplied. (The connecting cable length, 0.5m, 3m, 5m or 10m, can be specified.) Note that the cutout size in the breaker front plate varies depending on the MDU mounting method.

\*2 The 250A frame models come with the studs in the package. In the case of the 400 and 800A frame models, the studs are fitted before shipment. Specify the mounting direction.

\*3 These are cassette-type devices and can be installed by the user.

\*4 When the following devices are installed on the built-in display type, the built-in display unit must be separately mounted.  
250A frame: Accessories with SLT or module on the right pole side  
400/800A frame: Accessories on right pole side

\*5 The breaker with alarm contact output is provided with the module on the right side and requires a control power supply (common to 100 to 240VAC/DC, 50/60Hz, 5VA). The PAL output does not operate if the MDU is connected and the control power is not applied to the MDU.  
The output method of PAL of the alarm contact output can be set to "self-holding" or "automatic reset" from the MDU. The default setting is "automatic reset."

\*6 The breaker with alarm contact output (PAL), (TI) is not available.

\*7 It does not have an isolation function except for 400 to 800A frame models.

\*8 It can be manufactured only in the case of panel mounting.

\*9 For a 250A frame model with breaker mounting and PAL, the cover dedicated for the MDU is used. When placing an order only for the terminal cover, add MP to the end of the model name. (Example: TCL-2SV3MP)

\*10 In the case of external mounting, the cover dedicated for the MDU is used. When placing an order only for the terminal cover, add -MDUB to the end of the model name. (Example: TCL-2SV3-MDUB)

\*11 250A frame 4-pole models are not provided with TTC for external mounting.

## Measuring Display Unit Breakers (Circuit Breakers with Measuring Display Unit)

### ● Three major features of Measuring Display Unit Breakers

1. Saving of space and labor for installation
2. Improved and diversified functions
3. Provision of total cost advantages

Measuring Display Unit Breakers with built-in VT and CT and Measuring Display Unit realize measurement, display and transmission of electric circuit information in small space with less installation and wiring work and provide total cost advantages.

The Measuring Display Unit Breakers full of functions in small bodies are suitable for monitoring and protection of electric circuits and maintenance of equipment. A wide variety of models applicable to various networks supports the customers' energy saving activities through detailed energy control as energy saving supporting devices.

### ● Simply realizing measurement and monitoring of electric circuits for supporting various types of energy saving control

The circuit breakers measure and display the load current, line voltage, electric power, electric energy, harmonic current, leak current and power factor to realize detailed energy control. They support customers' energy saving control.

#### ◆ Installation type

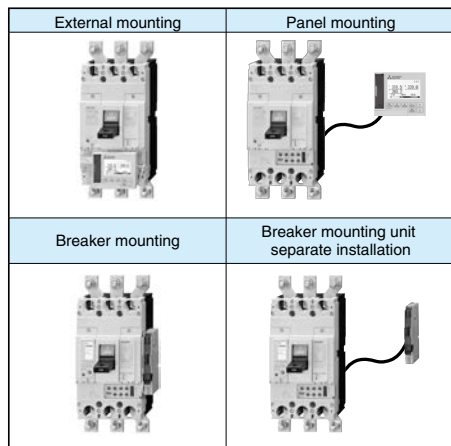

#### ◆ Communication type

	External mounting	Panel mounting	Breaker mounting	Breaker mounting unit separate installation
CC-Link	○	○	○	○
Pulse Output	○	○	○	○
MODBUS RTU	○	○	-	-
No Transmission	○	○	○	○

#### ◆ Measuring Display Unit cable list

Type name	Cable length
MDU-DP-CB-05M	0.5m
MDU-DP-CB-2M	2m
MDU-DP-CB-3M	3m
MDU-DP-CB-5M	5m
MDU-DP-CB-10M	10m

#### ◆ Measuring Display Unit list

Model type	Type name	Remarks
CC-Link communication	MDU-BC ○○○	<ul style="list-style-type: none"> <li>• The model names do not include ○○○.</li> <li>• In the case of external mounting, specify the A frame type in ○○○.</li> <li>• For example, when the circuit breaker NF400-SEW with MDU and the Measuring Display Unit with CC-Link communication are combined, the model name is MDU-BC400. If 800A frame is used, specify 800 in ○○○.</li> <li>• In the case of panel mounting, specify the cable length (0.5m, 2m, 3m, 5m or 10m) in ○○○. For example, when the Measuring Display Unit with CC-Link communication is installed on the panel with a 3m cable, the model name is MDU-BC-PANEL 3M.</li> </ul>
MODBUS communication	MDU-BM ○○○	
Electric energy pulse output	MDU-BP ○○○	
No transmission	MDU-BN ○○○	

#### ◆ Visibility and operability improvement

##### Improved visibility

When an alarm or fault occurs, the LCD backlight changes from white to red.



The display direction can be switched.

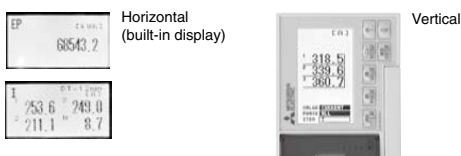

##### Improved operability

The multi-function display screen reduces the number of operations.



(Example) Current value of phase 1  
(Example) Line voltage between phases 1 and 2

Since any two elements can be constantly set in one window, the number of repeated operations can be reduced. (Up to 8 elements in four windows can be set.)

## Specifications for Measuring Display Units (MDU)

The measurement and display items vary depending on the model and A frame.

Measurement/stored item (accuracy)(*)1)(2)(3)		Function	Display	Storage (*4)	With electric energy pulse output (*5)	With CC-Link communication	With MODBUS communication	Remarks	
Load current (±1.0%)	Present value	Each phase	○	—	—	○	○		
		Total (average) (*7)	—	—	—	○	○		
		Max. phase	—	—	—	○	○		
	Demand value (*6)	Each phase	○	—	—	○	○		
		Max. phase	○	—	—	○	○		
		Max. demand value of all phases	○	○	—	○	○		
Time of occurrence of max. demand value of all phases			○	○	—	○	○		
Line voltage (±1.0%)	Present value	Between each two lines	○	—	—	○	○		
		Total (average) (*7)	○	—	—	○	○		
	Max. value between all lines			○	○	—	○	○	
	Time of occurrence of max. value between all lines			○	○	—	○	○	
Harmonic current (±2.5%)	Present value	Fundamental wave of each phase	○	—	—	○	○		
		Individual harmonic current of each phase	○	—	—	○	○		
		Total harmonic current of each phase (*8)	○	—	—	○	○		
	Max. fundamental wave value of all phases			○	○	—	○	○	
	Time of occurrence of max. fundamental wave value of all phases			○	○	—	○	○	
	Max. value of individual harmonic current of all phases			○	○	—	○	○	
	Time of occurrence of max. value of individual harmonic current of all phases			○	○	—	○	○	
	Demand value (*6)	Total harmonic current of each phase (*8)		○	—	—	○	○	
		Max. total demand value of all phases		○	○	—	○	○	
		Time of occurrence of max. total demand value of all phases		○	○	—	○	○	
Total distortion rate of each phase			○	—	—	○	○		
Individual content of each phase			○	—	—	○	○		
Electric power (±1.5%)	Present value		○	—	—	○	○		
			○	—	—	○	○		
	Demand value (*6)	Present value	○	○	—	○	○		
		Max. value	○	○	—	○	○		
Time of occurrence of max. value			○	○	—	○	○		
Reactive power (±2.5%)	Present value		○	—	—	○	○		
			○	—	—	○	○		
	Demand value (*6)	Present value	○	○	—	○	○		
		Max. value	○	○	—	○	○		
Time of occurrence of max. value			○	○	—	○	○		
Electric energy (±2.0%) (*9)	Integrated value		○	○	○	○	○	Value accumulated to the present after the previous reset	
	Amount for last one house		○	—	—	○	○		
	Max. value of amount for one hour		○	○	—	○	○		
	Time of occurrence of max. value of amount for one hour		○	○	—	○	○		
Reactive energy (±3.0%) (*9)	Integrated value		○	○	—	○	○	Value accumulated to the present after the previous reset	
	Amount for last one house		○	—	—	○	○		
	Max. value of amount for one hour		○	○	—	○	○		
	Time of occurrence of max. value of amount for one hour		○	○	—	○	○		
Cause of fault (*10)	Fault current (accuracy: ±15%)		○	○	—	○	○	Information on and causes of faults after the previous reset or the latest fault (Continuous monitoring)	
	Cause of fault		○	○	—	○	○		
Power factor (±5.0%)	Present value		○	—	—	○	○		
	Max. value		○	○	—	○	○		
	Time of occurrence of max. value		○	○	—	○	○		
Frequency (±2.5%)	Present value		○	—	—	○	○		
Phase sequence	—		○	—	—	○	○	Except 250A frame	
Status of breaker	Tripping status of breaker (AL)		—	—	—	○	○	When the alarm switch for MDU transmission (option) is installed	
	ON/OFF status of breaker (AX)		—	—	—	○	○	When the auxiliary switch for MDU transmission (option) is installed	
	Number of times of tripping of breaker		—	○	—	○	○	When the alarm switch for MDU transmission (option) is installed	
	Number of times of opening/closing of breaker		—	○	—	○	○	When the auxiliary switch for MDU transmission (option) is installed	
Breaker alarms (*11)	PAL, OVER, IDM_AL, ILA_AL, IUB_AL		○	—	—	○	○	The LC display, transmission and contact output of the PAL function of 250A frame model are activated when the PAL module (option)	
	Neutral wire open phase alarm (NLA)		○	—	—	○	○	The neutral wire open phase alarm is displayed only. When the phase wire system is set to 1-phase 3-wire system, the function is turned on. Rated operating overvoltage: 135VAC. Operating time: 1s	
Initial setting	Time setting		○	—	—	○	○	It is necessary to re-set at the initial setting and after power failure (no power failure compensation).	
	Demand time limit setting (*6)		○	○	—	○	○	The default setting is 2min. The time limit can be set in one-minute increments in the range from 0 to 15min.	
	IDM_AL (current demand alarm)		○	○	—	○	○	The default setting of the function is OFF. Function: ON/OFF. Pickup current: 50 to 100% (in 1% steps). Demand time limit: Can be set to 1 to 10min (1min steps), 15, 20, 25 or 30min.	
	ILA_AL (current open phase alarm)		○	○	—	○	○	The default setting of the function is OFF. Function: Can be set to ON or OFF. Pickup current: Fixed to 10% (no setting). Operating time: 30s (no setting).	
	IUB_AL (current unbalance alarm)		○	○	—	○	○	The default setting of the function is OFF. Function: Can be set to ON or OFF. Pickup current: Fixed to 30% (no setting). Operating time: 30s (no setting).	
	Phase switching setting		○	○	—	○	○	The default setting is "no phase switching."	
	Alarm retention (self-holding/automatic reset) setting		○	○	—	○	○	The default setting is "automatic reset."	
	Phase wire system		○	○	—	○	○	The default setting is "3-phase 3-wire" for 3-pole breakers or "3-phase 4-wire" for 4-pole breakers.	
	Electric energy arbitrary setting		○	○	—	○	○		
	Reactive energy arbitrary setting		○	○	—	○	○		
Display direction		○	○	—	○	○	The default setting is "horizontal" for mounting on breaker and mounting on panel or "horizontal" for built-in display and separate mounting of built-in display unit.		

- Notes: \*1 The term "each phase" for load current and harmonic current refers to the 1st, 2nd, 3rd or N-th phase. However, the N-th phase applies only to 4-pole breakers. The term "between each two phases" for line voltage refers to "between 1 and 2," "2 and 3," "3 and 1," "1 and N," "2 and N" or "3 and N." However, "between 1 and N," "between 2 and N" and "between 3 and N" apply only to 4-pole breakers. This unit measures data every 0.25s. Therefore, it may not measure the operating current even when a low-order circuit breaker operates.
- \*2 The term "each max. value" refers to the largest value during the period from the start of use (the previous reset) to the present.
- \*3 Each max. value cannot be individually cleared.
- \*4 In the nonvolatile memory, the integrated values of electric energy and reactive energy are stored at power failure and every 30minutes, the fault current and its cause are stored upon occurrence of the fault, each set value is stored when it is set, and others are stored every 30minutes.
- \*5 Every time the electric energy is integrated into a pulse unit (the unit can be set to any of 1kWh, 10kWh, 100kWh, 1000kWh and 10000kWh), a pulse is output. The pulse can be counted with a PLC.)
- \*6 The demand time limit cannot be set individually. The setting is common.
- \*7 When the phase wire system is set, the average values of load current and line voltage are calculated as shown below.

Phase wire system	Average present value of current	Average present value of voltage
1-phase 2-wire system	Average present value of current = current of the 3rd phase	Average present value of voltage = voltage between 2 and 3
1-phase 3-wire system	Average present value of current = (current of the 1st phase + current of the 3rd phase)/2	Average present value of voltage = (voltage between 1 and 2 + voltage between 2 and 3)/2
3-phase 3-wire system	Average present value of current = (current of the 1st phase + current of the 2nd phase + current of the 3rd phase)/3	Average present value of voltage = (voltage between 1 and 2 + voltage between 2 and 3 + voltage between 3 and 1)/3

- \*8 Sum of 3rd to 19th harmonic components excluding fundamental wave components
- \*9 The reverse power is not measured.
- \*10 When overload or short circuit fault occurs and the current value exceeds the upper limit of the fault current measurement range (rated current 125 to 250A (adjustable): 4000A, rated current 50, 60, 75, 100 and 125A (fixed): 2000A), some 250A frame models may not display the cause of the fault or measure the fault current. The display of cause of fault caused by instantaneous tripping and the measurement of the fault current are enabled when the AL for MDU transmission (option) is installed.
- \*11 The display of alarm on the MDU is automatically reset when the alarm retention setting is "automatic reset." When the alarm retention method is "self-holding," the alarm is self-held. When the setting is "self-holding," the alarm is reset by performing the alarm reset operation (collective reset). "OVER" is automatically reset regardless of the setting.
- \*12 Depending on the usage environment, because of deteriorations brightness of the backlight could be decreased. If you need to replace the display part, please kindly let us know.
- Remarks: (1) We use LCD for the display part of this product. The LCD may have bright spots (spots that are constantly on) and dark spots (spots that do not light) by its nature. The LCD has many display elements, and it is impossible to completely eliminate the occurrence of bright and dark spots. The occurrence of bright and dark spots is not a defect of this product.
- (2) For LCD, depending on the characteristics of the material there could be deterioration of brightness (Bleeding and blot of display part, thinning of letters, deterioration of brightness of the backlight). If you need to replace the display part, please contact the local sales office or sales representative.

## Specifications for Measuring Display Units (MDU)

Item	Specifications	
Data update cycle	250ms (harmonic current: 2s)	
Measurement rating input	Voltage circuit	440V (3-phase 4-wire system is applicable only to 4-pole models.)
	Current circuit	Load current/harmonic current: 250A/400A/630A/800A (Automatically discriminated. Determined according to the A frame of breaker.)
	Electric power	$\sqrt{3} \times$ Measurement rating current $\times$ 440V (power factor 1)
	Reactive power	$\sqrt{3} \times$ Measurement rating current $\times$ 440V (power factor 0)
	Frequency	50Hz/60Hz (Automatic discrimination of frequency)
Tolerances	Current, Voltage: $\pm 1.0\%$ (of Measurement rating input) Electric power: $\pm 1.5\%$ (of Measurement rating input) Reactive power: $\pm 2.5\%$ (of Measurement rating input) Harmonic current: $\pm 2.5\%$ (of Measurement rating input) Power factor: $\pm 5.0\%$ for an electric angle of $90^\circ$ Frequency: $\pm 2.5\%$ of actual value Electric energy: $\pm 2.0\%$ of actual value (voltage range from 100V to 440V, range from 5 to 100% of current rating, power factor 1) Reactive energy: $\pm 3.0\%$ of actual value (voltage range from 100V to 440V, range from 10 to 100% of current rating, power factor 0) Fault current: $\pm 15\%$ of actual value (*1)	
Demand time limit setting range	0 to 15min (in 1min steps)	
Power failure compensation	(1) Wh (integrated value), varh (integrated value) (2) Max. value (3) Setting data	Stored in the nonvolatile memory * Wh and varh are stored at power failure and every 30min. The max. value is stored every 30min. The setting data is stored when the data is set.
	Clock	No power failure compensation
Clock accuracy	Error: approx. 1min/month	
Outside dimensions (unit: mm)	See "Features and outline."	
Control power	Common to 100 to 240VAC/DC, 50/60Hz (allowable voltage range: 85% to 110%), 12VA * Rush current flows transiently when the control power supply is turned on. (Rush current max. value 2A, current carrying time 1ms (240VAC))	
Conditions for use	(1) Use under the conditions specified in "2. Normal Service conditions" and "3. Mounting and Connections" in "8. Handling and Maintenance." (2) Do not use in places with high temperature, high humidity, direct sunlight, or where static electricity is generated. When connecting electrical wires such as connection cables, transmission lines, and communication lines between the MDU breaker and the MDU, be careful not to generate static electricity. It may lead to malfunction and shortened service life.	

Notes: \*1 The measurement of fault current caused by instantaneous tripping of the 250A frame breaker is enabled when the alarm switch for MDU transmission (option) is installed on the MDU breaker body.

### Electric energy pulse output

Item	Specifications
Output element	Solid state relay (SSR), no-voltage a contact (Ca and Cb terminals: no polarity)
Contact capacity	Common to 24VDC and 100 to 200VAC, 20mA
Output pulse unit	1, 10, 100, 1000 or 10000kWh/pulse (selectable) (*1)
Output pulse width	0.34 to 0.45s
Max. wiring length	100m

Notes: \*1 The default setting is 1kWh/pulse.

### MODBUS communication

Item	Specifications
Communication system	RS-485/2-wire system/half-duplex communication
Communication protocol	MODBUS-RTU communication (binary data transfer)
Synchronization system	Asynchronous
Connection system	Multi-drop wiring
Transmission rate	2,400, 4,800, 9,600, 19,200, 38,400bps
Bit length	8bits
Stop bit	1bit or 2bits
Parity bit	ODD, EVEN, NONE
Slave address	1 to 127
Response time	Response is sent 1 sec or less after the completion of receipt of query data.
Termination resistance	120Ω 1/2W
Max. transmission distance	1,200m
Max. number of connected units	31units/system
Transmission line	SPEV(SB)-MPC-0.2×1P or more (Fujikura Dia Cable, Ltd.) or its equivalent

Note: MODBUS communication is applicable to mounting on breaker and mounting on panel.

### CC-Link communication

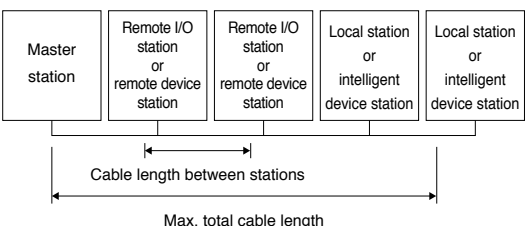
Item	Specifications																		
Communication speed	10M/5M/2.5M/625k/156kbps																		
Communication system	Broadcast polling system																		
Synchronization system	Frame synchronization system																		
Coding system	NRZI																		
Transmission format	Conforming to HDLC																		
Number of occupied stations	Remote device occupying one station																		
Number of connected units	Meet the following conditions. Up to 42 units can be connected when only MDU breakers are used. Condition 1 for number of connected units $[(1 \times a) + (2 \times b) + (3 \times c) + (4 \times d)] \leq 64$ a: Number of units occupying 1 station, b: Number of units occupying 2 stations c: Number of units occupying 3 stations, d: Number of units occupying 4 stations Condition 2 for number of connected units $[(16 \times A) + (54 \times B) + (88 \times C)] \leq 2304$ A: number of units with 1 remote I/O station $\leq 64$ , B: number of remote device stations $\leq 42$ , C: number of local stations $\leq 26$																		
Station No.	Set in the range from 1 to 64. (Set the station No. without fail.)																		
CC-Link version	CC-Link Ver.1.10																		
Max. total cable length and cable length between stations	 <p>Cable compatible with CC-Link Ver.1.10 (110-ohm termination resistance is used.)</p> <table border="1"> <thead> <tr> <th>Communication speed</th> <th>156kbps</th> <th>625kbps</th> <th>2.5Mbps</th> <th>5Mbps</th> <th>10Mbps</th> </tr> </thead> <tbody> <tr> <td>Cable length between stations</td> <td colspan="5">0.2m or more</td> </tr> <tr> <td>Max. total cable length</td> <td>1200m</td> <td>900m</td> <td>400m</td> <td>160m</td> <td>100m</td> </tr> </tbody> </table>	Communication speed	156kbps	625kbps	2.5Mbps	5Mbps	10Mbps	Cable length between stations	0.2m or more					Max. total cable length	1200m	900m	400m	160m	100m
Communication speed	156kbps	625kbps	2.5Mbps	5Mbps	10Mbps														
Cable length between stations	0.2m or more																		
Max. total cable length	1200m	900m	400m	160m	100m														
Connecting cable	Cable compatible with CC-Link Ver.1.10 (shielded 3-core twisted pair cable) * Cables made by different manufacturers can be used if the cables are compatible with Ver.1.10.																		

Note: For more information, refer to the website of CC-Link Partner Association (<http://www.cc-link.org/>).

## ● Cautions when Using Measuring Display Unit Breakers (common instructions)

### Measuring accuracy

(1) Electric current measurement accuracy

The MDU electric current measurement accuracy is  $\pm 1.0\%$  of  $I_n$  of the circuit breaker.

For example, the permissible difference of NF400-SEW with MDU is 4.0A ( $400A \times 1.0\%$ ), so the permissible difference from a current of 0A to 400A would be  $\pm 4.0A$ .

If the measurement value is less than 1.0%, the display value is cut off to 0A. However, if the current is 0.4% or more of the rated value, the electric power and electric energy are measured.

(2) When the current is cut off, the current is displayed as 0 A. However, if the current is 0.4% or more of the measurement rated current, the electric energy is measured.

(3) The accuracy of power factor is the percentage to electrical angle of  $90^\circ$ . A power factor of 50% or less is displayed as a reference value.

(4) The accuracy of electric energy is  $\pm 2.0\%$  of the true value in the case of WS-V Series Measuring Display Unit Breakers in the range of measurement rated voltage (100V to 440V)  $\times$  current (measurement rated current of 5 to 100%).

### How to use Measuring Display Unit Breaker on single-phase 2-wire circuitry

Connect the breaker as shown in the right figure.

The phase 1 on the load side is charged. Insulate it.

As measurement data, use the current of the phases 2 and 3 and the voltage between the phases 2 and 3.

Although the current of the phase 1 and the voltage between the phases 1 and 2 and the phases 3 and 1 are measured, ignore the measurements. The Measuring Display Unit is designed for 3-phase 3-wire and single-phase and 3-wire circuits.

On W & WS Series Measuring Display Unit Breakers, the average values of load current and line voltage are calculated from the values of the phases 1, 2 and 3 (between the phases).

Ignore these measurement values.

Also when the breaker is used on a single-phase 3-wire circuit, ignore these values.

When using any WS-V Series Measuring Display Unit Breaker, set the phase and wire type.

Connection on single-phase 2-wire circuit

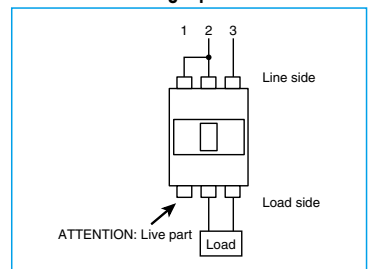

### Phase sequence of Measuring Display Unit Breaker

The phase sequence of Measuring Display Unit Breaker can be set by using the phase switching function as shown below.

When the breaker is installed vertically with the power supply side upward (see the right figure), the phase sequence is set as stated below.

No phase switching: 1, 2, 3 and N from the left (default)

With phase switching: 3, 2, 1, and N from the left

Set the phase sequence in accordance with the installation and wiring methods.

Notes (1) The phase N is provided only on 4-pole circuit breakers.

(2) Note that the position of the phase N is unchanged regardless of the phase switching setting.

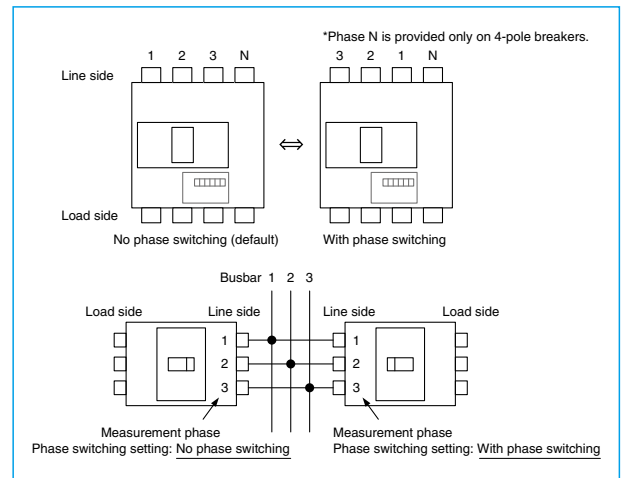

### Reverse connection of Measuring Display Unit Breaker

The Measuring Display Unit Breakers cannot be connected with the power supply and load sides set reversely.

### Installation of Measuring Display Unit Breaker in close contact

The Measuring Display Unit Breakers must not be installed in close contact. To allow routing of the connection cables and installation of their connectors, provide the following clearance to the right side of the breaker when installing:

(1) External mounting or Panel mounting: 30mm or more

(2) Breaker mounting or Breaker mounting unit separate installation: 40mm or more

### ● Cautions when using Measuring Display Unit Breaker (For Measuring Display Unit) Transmission method

- (1) One of No transmission, with pulse output, with CC-Link communication and with MODBUS communication should be specified.
- (2) When With transmission is selected, data which can be transmitted depends on the function of the Measuring Display Unit Breaker body. The transmission options cannot be installed or changed later. Specify the options when issuing the initial order.
- (3) For the maximum number of connected units and transmission distance for each transmission type, see the following tables for CC-Link communication and MODBUS communication.

### Installation of Measuring Display Unit

- (1) When the installation of Measuring Display Unit on panel has been specified, the breaker will come with the panel mounting parts, mounting screws and 2m connecting cable (standard). (The 0.5, 3, 5 or 10m connecting cable can be specified.)
- (2) If the installation position of the Measuring Display Unit is changed from the panel to the body or vice versa, the Measuring Display Unit and the breaker body must be returned to the manufacturer for modification.

### Measuring Display Unit Breaker with CC-Link communication and MODBUS communication (External mounting type)

- (1) In the case of CC-Link and MODBUS, front plate cutout is not possible.

### ● Change of display direction for breaker mounting

<WS-V Series Measuring Display Unit Breaker>

- (1) When installing the Measuring Display Unit on the breaker body installed in the horizontal direction, the direction of the display can be changed according to the installation direction.
- (2) The display direction is set on the display unit.

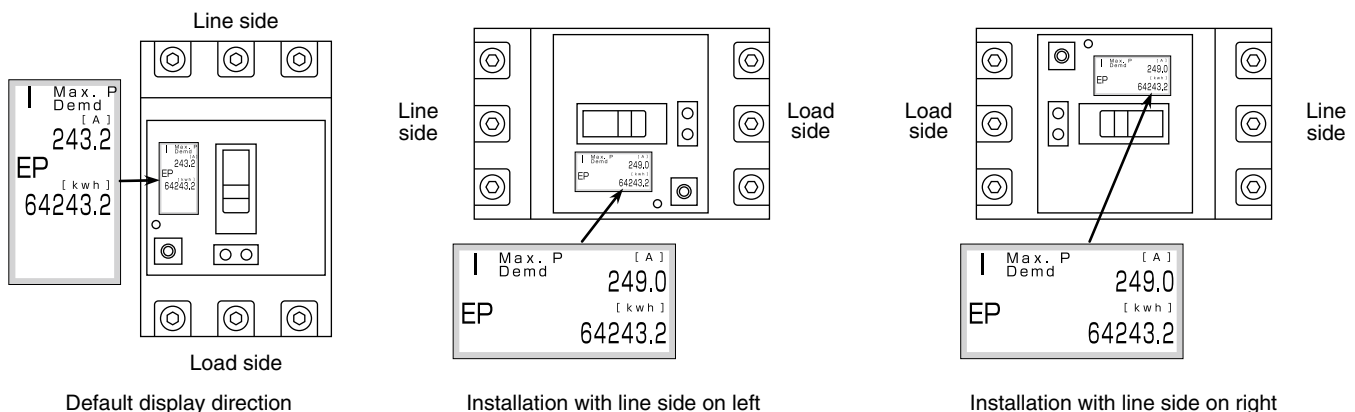

<View setting (vertical or horizontal)>

[Default value: V-VIEW (horizontal display)]

- Select VIEW on the LCD setting selection screen. (Screen [1])
  - Press ENTER to switch to the view setting display screen. (Screen [2])
- Setting value switches through V-VIEW ⇔ H-VIEW1 ⇔ H-VIEW2 ⇔ V-VIEW...
- Press ENTER to decide the setting.
- Select YES on the allow changes screen and press ENTER to decide the setting. (Screen [3])

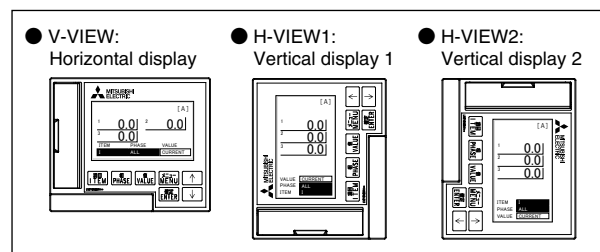

[LCD setting selection screen]

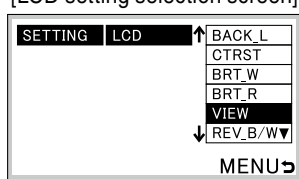

Screen [1]

Select with UP/DOWN

[View setting display screen]

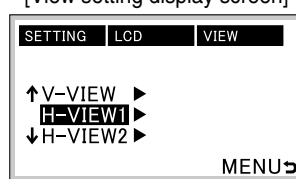

Screen [2]

View setting value Change with UP/DOWN

[Allow changes screen]

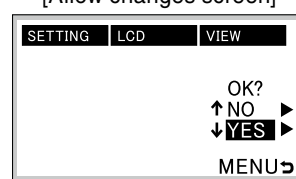

Screen [3]

Select NO ⇔ YES with UP/DOWN

## DC High-Voltage Circuit Breakers

Frame (A)	50	
Model	NF63-HDV	
Rated current In (A)	15 20 30 40 50	
Reference ambient temperature 40°C		
Number of poles	2	3
Rated insulation voltage Ui (V)	600	690
Rated short-circuit breaking capacities (kA)	400V	10/5
	600V	-
Rated impulse withstand voltage Uimp (kV)	8	
Current	DC	
Suitability for isolation	Yes	
Reverse connection	Available *1	
Operating temperature degree	-10~+40°C *2	
Number of operating cycles	Without current	10000
	With current	1500
Pollution degree	Without current	3
	With current	3
Overall dimensions (mm)	50	75
	130	68
Mass of front type (kg)	0.5	0.7
	Front (F)	
Installation and connection	Rear (B)	(Round stud)
	Flush plate (FP)	(Round stud) *3
Cassette-type accessories	Plug-in (PM)	-
	Alarm switch (AL)	●
External accessories	Auxiliary switch (AX)	●
	Shunt trip (SHT) *4	●
Terminal cover	Undervoltage trip (UVT) *4	●
	With lead-wire terminal block (SLT)	●
Handle lock device	LC	●
	HL	●
External operating handle	HL-S	●
	F type	●
Terminal cover	V type	●
	S type	-
IEC35mm mounting rail adapter	C type	-
	BOX for MCCB	-
Electrical operation device (NFM)	Mechanical Interlock (MI)	-
	CE marking	Self-declaration
UKCA marking	CCC	Certified
	Automatic tripping device	Thermal-magnetic
Trip button	Page of Characteristics and dimensions	230

Notes: \*1 Connection methods are available only shown in the following figure.

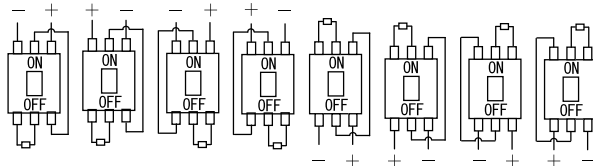

- \*2 To reduce a current value as follows when the ambient temperature is over 40°C. The average value of the ambient temperature during 24hours shall not exceed 35°C. To use a wire having a heat resistance suitable for the temperature when using at high temperature.
  - 50°C...90% or less
  - 60°C...70% or less
  - 70°C...65% or less
  - (To use less than 6 hours per day, when the ambient temperature is 70°C. Long time use at 70°C causes life time reduction.)
- \*3 This product is shipped from the factory only in an assembled state, cannot be mounted by users.
- \*4 A shunt trip device (SHT) and an undervoltage trip device (UVT) is not available over 60°C of the ambient temperature.

Remark:\*1 The time constant of the circuit is 5ms or less.

Frame (A)	125	225	250
Model	NF125-HDVA	NF250-HDVA	
Rated current In (A)	125	125 150 175 200 225	250
Reference ambient temperature 40°C			
Number of poles	4		
Rated insulation voltage Ui (V)	1000		
Rated short-circuit breaking capacities (kA)	IEC 60947-2		10/5
	EN 60947-2		
Rated impulse withstand voltage Uimp (kV)	8		
Current	DC		
Suitability for isolation	Yes		
Reverse connection	Available *1		
Working ambient temperature	-25~+40°C *2,*3		
Number of operating cycles	Without current	8,000	
	With current	1,000	
Pollution degree	Without current	2	
	With current	2	
Overall dimensions (mm)	140	165	
	68	92	
Mass of front type (kg)	2.0		
	Front type (F)		
Connection	Rear type (B)	● *4	
	Plug-in type (PM)	-	
Cassette-type accessories	Alarm switch (AL) (Normal/Micro load)	● *2	
	Auxiliary switch (AX) (Normal/Micro load)	● *2	
External accessories	Shunt trip (SHT)	● *3	
	Undervoltage trip (UVT)	● *3	
Lead-wire terminal block (SLT)	LC	● *2	
	HL	● *2	
Handle lock device	HL-S	● *2	
	F type	● *3	
External operating handle	V type	● *3	
	Terminal cover (TC-L, TC-LL *6, TC-S, BTC)	● *2	
IEC35mm mounting rail adapter	BOX for MCCB	-	
	Electrical operation device (NFM)	-	
Mechanical Interlock (MI)	CE marking	Self-declaration	
	UKCA marking	Self-declaration	
CCC	Automatic tripping device	Thermal-magnetic	
	Trip button	Equipped	
Page of Characteristics and dimensions	232	232	232

Notes: \*1 Although wiring method as right figure is described on MCCB, other wiring method mentioned in below Wiring diagram chart is also available.

### Wiring diagram chart

	Normal / Reverse connection	Non-grounded system (Protection + Disconnection)	Grounded system (Protection)	Grounded system (Protection + Disconnection)	Other non-grounded system (Protection + Disconnection)
Normal connection					
Reverse connection					
Applicable voltage (V)	≤ 1000	≤ 1000	≤ 750	≤ 1000	≤ 1000

- Wires between terminals are prepared by a customer.
- Wires should be selected according to the rated current. Otherwise, there is a risk to change the operating characteristics and unnecessary operation of MCCB.
- \*2 To reduce a current value as follows when the ambient temperature is over 40°C. The average value of the ambient temperature during 24 hours shall not exceed 35°C. To use a wire having a heat resistance suitable for the temperature when using at high temperature.
  - 50°C...90% or less
  - 60°C...70% or less
  - 70°C...65% or less
- \*3 Caution using at ambient temperature 70°C
  - To use less than 6 hours per day at 70°C. Otherwise, it will cause life time reduction.
  - There is a risk of tripping during switching operation or due to vibration and shock. In such case, please make the breaker "Reset" after a while.
- \*4 Caution using at low ambient temperature
  - To use in an environment without frost and ice.
- \*5 Shunt trip device (SHT), undervoltage trip device (UVT) and external operating handle (F type, V type) should be used at standard operating condition. In case of external operating handle (F type, V type), those can be used at up to 60°C with reducing a current values according to the above \*2①.
- \*6 In case of rear type, rear terminal cover is included as standard and it must be used.
- \*7 Circuit breakers for NF250-HDVA have obtained CCC certificate. Please consult us for details.
- \*8 It is only shipped with MCCB. Please specify "TC-LL" when ordering.
- \*9 If the wire size 150mm<sup>2</sup> is used, please use cramp terminal CB150-S8 (with or without insulation tape).

Remark:\*1 Time constants of circuit are as follows:

Range of current	Time constant
Rated current	2ms or less
Short circuit current	5ms or less

## DC High-Voltage Circuit Breakers

Frame (A)		400		800			
Model		NF400-HDW		NF800-HDW			
Rated current In (A) Reference ambient temperature 40°C		250 300 350 400		500 600 630 700 800			
Number of poles		3		4			
Rated insulation voltage Ui (V)		800		1000			
Rated short-circuit breaking capacities (kA)	IEC 60947-2 EN 60947-2 GB/T 14048.2 (Icu/Ics)	DC	1000V	-	10/5	-	10/5
			750V	10/10	10/10	10/10	10/10 *6
Rated impulse withstand voltage Uimp (kV)		8		8			
Current		DC					
Suitability for isolation		Yes					
Reverse connection (terminals unmarked)		Available					
Number of operating cycles	Without current	5000		3000			
	With current	1000		500			
Pollution degree		3		2			
Overall dimensions (mm)		a	140	185	210	280	
		b	257		275		
		c	109 *1		109 *1		
		ca	161 *1		161 *1		
		ca2	161 *1		161 *1		
Connection	Front type (F)	● Busbar terminal		● Busbar terminal			
	Rear type (B)	● Bar stud *2		● Bar stud *2			
Cassette-type accessories (Option)	Alarm switch (AL)	● *3		● *3			
	Auxiliary switch (AX)	● *3		● *3			
	Shunt trip (SHT)	● *3		● *3			
	Undervoltage trip (UVT)	● *4		● *4			
	With lead-wire terminal block (SLT)	●		●			
External accessories (Option)	Handle lock device	LC	-	-	-		
		HL	●	●	●		
		HL-S	●	●	●		
	External operating handle	F type	●	●	●		
		V type	●	●	●		
		S type	-	-	-		
C type	-	-	-				
Terminal cover	● (TC-L, TTC,BTC *5)		● (TC-L, TTC,BTC *5)				
CE marking			Self-declaration				
UKCA marking			Self-declaration				
CCC			Certified				
Automatic tripping device			Thermal-magnetic				
Trip button			Equipped				
Page of Characteristics and dimensions		234		234			

- Notes: \*1. Dimensions are different from NF400-SW/SEW/HEW or NF800-SEW/HEW.  
 \*2. Order with the breaker.  
 \*3. Available to install at customer site.  
 \*4. Only Reset type is available. (Non-reset type is not available.)  
 \*5. BTCs for NF400-HDW or NF800-HDW are exclusive.  
 \*6. GB/T 14048.2 is not applied.

Remark: \*1. Right diagrams as wiring method are shown on breaker, others shown in "Wiring diagrams" are also available.  
 \*2. Time constants of circuit are as follows:

Range of current	Time constant
Rated current	2ms or less
Short circuit current	5ms or less

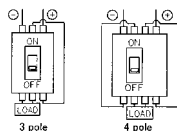

### Wiring diagrams

For 3 pole

Normal / Reverse connection	Non-grounded system (Protection + Disconnection)	Grounded system (Protection)	Grounded system (Protection + Disconnection)	Other non-grounded system (Protection + Disconnection)
Normal connection				
Reverse connection				
Applicable voltage (V)	≤ 750	≤ 750	≤ 500	≤ 750

For 4 pole

Normal / Reverse connection	Non-grounded system (Protection + Disconnection)	Grounded system (Protection)	Grounded system (Protection + Disconnection)	Other non-grounded system (Protection + Disconnection)
Normal connection				
Reverse connection				
Normal connection				
Reverse connection				
Applicable voltage (V)	≤ 1000	≤ 1000	≤ 750	≤ 1000

Model	MCB											
	BH-D6					BH-D10				BH-DN		
Image												
Number of poles [P]	1	2	3	4(3+N) <sup>*1</sup>	2(1+N) <sup>*1</sup>	1	2	3	4(3+N) <sup>*1</sup>	2(1+N) <sup>*1</sup>		
Instantaneous tripping	Type B, C, D <sup>*2</sup>					Type B, C, D <sup>*2</sup>				Type C <sup>*2</sup>		
Rated insulation voltage $U_i$ [V]	440					440				230		
Rated current $I_n$ [A] at ambient temperature 30°C	0.5, 1, 1.6, 2, 3, 4, 6, 10, 13, 16, 20, 25, 32, 40, 50, 63					0.5, 1, 1.6, 2, 3, 4, 6, 10, 13, 16, 20, 25, 32, 40				6, 10, 16, 20		
Rated short-circuit capacity [kA]	IEC 60898-1 EN 60898-1 GB/T 10963.1 (lcn)	AC	230V	6	–	–	6	10	–	–	4.5	
			230/400V	6	–	–	–	10	–	–	–	
			400V	–	6	–	–	–	10	–	–	
Number of operating cycles	Without current					10,000				20,000		
	With current					10,000				20,000		
Dimensions [mm]		a	18	36	54	72	36	18	36	54	72	
		b	87					87				88
		c	44					44				44
		ca	70					70				70
Type of overcurrent release	Thermal-magnetic					Thermal-magnetic				Thermal-magnetic		
Mounting	IEC35mm rail					IEC35mm rail				IEC35mm rail		
Applicable wire size	1 to 25mm <sup>2</sup>					1 to 25mm <sup>2</sup>				1 to 10mm <sup>2</sup>		
Mass [kg]	0.15	0.3	0.45	0.55	0.25	0.15	0.3	0.45	0.55	0.12		
Accessories (optional)	Alarm switch (AL)					●				–		
	Auxiliary switch (AX)					●				–		
	Shunt trip (SHT)					●				–		
	Handle lock device (HL)					●				–		
Terminal connection	Solderless					Solderless				Solderless		
Based on standard	IEC 60898-1, EN 60898-1, GB/T 10963.1					IEC 60898-1, EN 60898-1, GB/T 10963.1				IEC 60898-1, EN 60898-1, GB/T 10963.1		
CE marking	Self-declaration					Self-declaration				Self-declaration		
UKCA marking	Self-declaration					Self-declaration				Self-declaration		
CCC	Certified					Certified				Certified		
Marine use approval	CCS <sup>*3</sup> , DNV					CCS <sup>*3</sup> , DNV				–		
Page of Characteristics and dimensions	236					236				237		

Notes: \*1 N pole is a switched neutral pole (without overcurrent release device).  
\*2 Type B: (3 In <, ≤ 5 In), Type C: (5 In <, ≤ 10 In), Type D: (10 In <, ≤ 20 In)  
\*3 Except for 4 poles breaker.

Model	For DC				
	BH-D10				
Image					
Number of poles [P]	1	2			
Instantaneous tripping	Type B, C <sup>*4</sup>				
Rated insulation voltage $U_i$ [V]	250				
Rated current $I_n$ [A] at ambient temperature 30°C	0.5, 1, 1.6, 2, 3, 4, 6, 10, 13, 16, 20, 25, 32, 40, 50, 63				
Rated short-circuit capacity [kA]	IEC 60898-2 EN 60898-2 GB/T 10963.2 (lcn)	DC	125V	10	–
		AC	250V	–	10
			230/400V	6	–
			400V	–	6
Number of operating cycles	Without current		8,000		
	With current		4,000		
Dimensions [mm]		a	18	36	
		b	87		
		c	44		
		ca	70		
Type of overcurrent release	Thermal-magnetic				
Mounting	IEC35mm rail				
Applicable wire size	1 to 25mm <sup>2</sup>				
Mass [kg]	0.15	0.3			
Accessories (optional)	Alarm switch (AL)		●		
	Auxiliary switch (AX)		●		
	Shunt trip (SHT)		●		
	Handle lock device (HL)		●		
Terminal connection	Solderless				
Based on standard	IEC 60898-2, EN 60898-2, GB/T 10963.2				
CE marking	Self-declaration				
UKCA marking	Self-declaration				
CCC	Certified				
Marine use approval	CCS				
Page of Characteristics and dimensions	236				

Notes: \*4 Type B: (4 In <, ≤ 7 In), Type C: (7 In <, ≤ 15 In) for DC  
Type B: (3 In <, ≤ 5 In), Type C: (5 In <, ≤ 10 In) for AC

### Tightening torque

Screw size	Tightening torque (N·m)	Model
M5	2.1±0.4	BH-D6, BH-D10, BV-D, KB-D SHTA400-05DLS, SHTD048-05DLS
M4	1.3±0.2	BH-DN, BV-DN, BV-DN6
M3.5	0.9±0.1	AL-05DLS, AX-05DLS, ALAX-05DLS AX2-05DLS



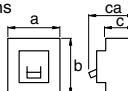

		RCCB	
Model		BV-D	
Image			
Number of poles [P]		$2(1+N)^{*1}$	$4(3+N)^{*1\ *3}$
Rated current $I_n$ [A] at ambient temperature 30°C		25, 40, 63	
Rated operational voltage $U_e$ [VAC]		230	230/400
Rated residual operating current $I_{\Delta n}$ [mA]		30, 300	
Max. operating time at $5I_{\Delta n}$ [s]		0.04	
Pulsating current sensitivity		Type A	
Residual operation		Dependent on line voltage	
Dimensions [mm]		a	36
		b	85
		c	44
		ca	70
Mass [kg]		0.2	0.35
Rated frequency [Hz]		50/60	
Short-circuit protective device		BH-D6	
Rated making and breaking capacity $I_m$ [A]		500( $I_n$ 25,40A), 630( $I_n$ 63A)	
Rated conditional short-circuit current $I_{nc}$ [kA]		6	
Rated residual making and breaking capacity $I_{\Delta m}$ [A]		500( $I_n$ 25,40A), 630( $I_n$ 63A)	
Rated conditional residual short-circuit current $I_{\Delta c}$ [kA]		6	
Reverse connection		Available	
Number of operating cycles	Without current	8,000	
	With current	8,000	
Type of overcurrent release		-	
Mounting		IEC35mm rail	
Applicable wire size		1 to 25mm <sup>2</sup>	
Terminal connection		Solderless	
Based on standard		IEC 61008-1, IEC 61008-2-2, EN 61008-1, GB/T 16916.1, GB/T 16916.22	
CE marking		Self-declaration	
UKCA marking		Self-declaration	
CCC		Certified	
Page of Characteristics and dimensions		238	

Notes: \*1 N pole is a switched neutral pole (without overcurrent release device).

\*2 Type C: ( $5 I_n < \leq 10 I_n$ )

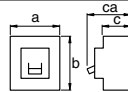
\*3 For use to three phase 4-wire type. When wiring to three phase 4-wire, connect the neutral line to the neutral pole. Not available for use to three phase 3-wire type.

		RCBO	
Model		BV-DN	BV-DN6
Image			
Number of poles [P]		$2(1+N)^{*1}$	
Rated current $I_n$ [A] at ambient temperature 30°C		6, 10, 16, 20, 25, 32, 40	3, 6, 10, 16, 20, 25, 32, 40
Rated operational voltage $U_e$ [VAC]		230	
Rated residual operating current $I_{\Delta n}$ [mA]		30, 100, 300	
Max. operating time at $5I_{\Delta n}$ [s]		0.04	
Pulsating current sensitivity		Type A	
Residual operation		Dependent on line voltage	
Rated short-circuit capacity [kA]	IEC 61009-1, EN 61009-1, GB/T 16917.1 (Icn)	AC 230V	4.5
Tripping characteristics		Type C <sup>*2</sup>	
Dimensions [mm]		a	36
		b	88
		c	44
		ca	70
Mass [kg]		0.19	
Rated frequency [Hz]		50/60	
Rated residual making and breaking capacity $I_{\Delta m}$ [A]		500	
Reverse connection		Available	
Number of operating cycles	Without current	20,000	
	With current	20,000 ( $I_n$ 6,10,16,20A) 15,000 ( $I_n$ 25A) 10,000 ( $I_n$ 32,40A)	
Type of overcurrent release		Thermal-magnetic	
Mounting		IEC35mm rail	
Applicable wire size		1 to 16mm <sup>2</sup>	
Terminal connection		Solderless	
Based on standard		IEC 61009-2-2, IEC 61009-1, EN 61009-1, GB/T 16917.1, GB/T 16917.22	
CE marking		Self-declaration	
UKCA marking		Self-declaration	
CCC		Certified	
Page of Characteristics and dimensions		239	

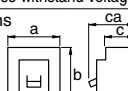
		Isolating switch			
Model		KB-D			
Image					
Number of poles [P]		1	2	3	$4(3+N)^{*4}$
Selectivity category		AC-22A			
Rated operational current $I_e$ [A] at ambient temperature 30°C		32, 63, 80			
Rated insulation voltage $U_i$ [V]		250		440	
Rated operational voltage $U_e$ [VAC]		230		400	
Rated short time withstand current $I_{cw}$ [A]		$20 \times I_e$ , 1s			
Rated short-circuit making capacity $I_{cm}$ [A]		$20 \times I_e$			
Rated impulse withstand voltage $U_{imp}$ [kV]		6			
Dimensions [mm]		a	18	36	54
		b			72
		c			87
		ca			44
Mass [kg]		0.09	0.18	0.27	0.36
Reverse connection		Available			
Number of operating cycles	Without current	20,000			
	With current	3,000			
Pollution degree		2			
Mounting		IEC35mm rail			
Applicable wire size		1 to 25mm <sup>2</sup>			
Terminal connection		Solderless			
Based on standard		IEC 60947-3, EN 60947-3, GB/T 14048.3			
CE marking		Self-declaration			
UKCA marking		Self-declaration			
CCC		Certified			
Marine use approval		CCS <sup>*5</sup> , DNV			
Page of Characteristics and dimensions		240			

Notes: \*4 Connect the neutral line to the neutral pole.

\*5 Except for 4 poles breaker.

## Accessories for Miniature Circuit Breakers

### Functions of Accessories

Accessory	Function
<b>AL</b> Alarm switch	Electrically indicates the trip status of the circuit breaker.
<b>AX</b> Auxiliary switch	Electrically indicates the On/Off status of the circuit breaker.
<b>SHT</b> Shunt trip	Electrically trips the circuit breaker from a remote location. Permissible working voltages are 70 to 110% of the AC rated voltage or 70 to 125% of the DC rated voltage.
<b>HL</b> Handle lock device	Device for locking the circuit breaker in the OFF position.

### Equipping of Accessories

Accessory \ Model	BH-D6	BH-D10	BH-DN, BV-DN, BV-DN6, KB-D, BV-D
<b>AL</b>	○	○	-
<b>AX</b>	○	○	
<b>SHT</b>	○	○	
<b>HL</b>	○	○	

○: Accessory equipped  
-: Accessory not equipped

### Specifications

Type		AL	AX	AL+AX	AX+AX
		AL-05DLS	AX-05DLS	ALAX-05DLS	AX2-05DLS
Contact	Configuration	1C	1C	2C	2C
	Contact capacity	400VAC, 2A	230VAC, 5A 120VDC, 0.4A	48VDC, 1.5A	24VDC, 4A
Function	Line	-	-	AX	AX
	Load	AL	AX	AL	AX
Connection		Screw terminal			
Compliance standard		IEC 60947-5-1			

Type	SHT	
	SHTA400-05DLS	SHTD048-05DLS
Cut-off switch	Equipped	
Voltage	110-400VAC	24-48VDC
Input power requirement	110VAC 60VA 230VAC 250VA 400VAC 750VA	24VDC 75VA 48VDC 300VA
Operating time [ms]	<20	
Connection	Solderless terminal	
Compliance standard	IEC 60947-2	

\* Secure a sufficient input power supply so that the voltage will not drop below the permissible lower working voltage (70% of the lowest rated voltage).  
\* The operating time denotes the time from when the rated voltage is applied to SHT until the time the main contact of the breaker starts to open.

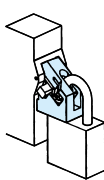
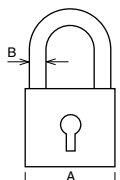
Type	HL	Reference diagram	Padlock
	HLF-05BHD		

Please use on the left pole for 2 pole breaker, on the center pole for 3 pole breaker, on the second pole or third pole from the left for 4 pole breaker. (OFF lock only)  
This device can be also used as a lock cover that can prohibit operation to ON position readily without any lock. One lot contains 10 pieces.

## Combinations of Accessories

Accessory connection combinations	AL	
	AX	
	2AX	
	ALAX	
	SHT	
	AX+SHT	
	AL+SHT	
	2AX+SHT	
ALAX+SHT		

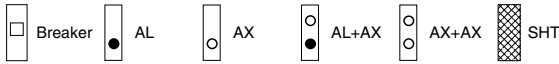

## Outline Drawing

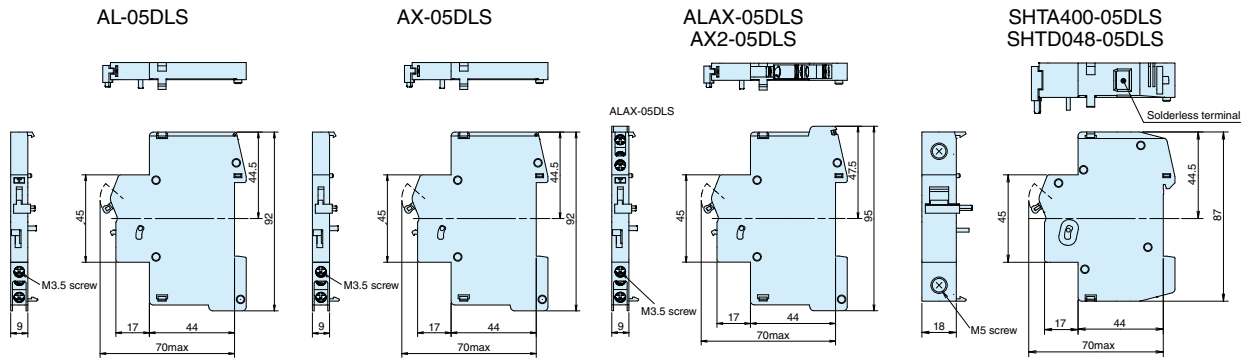

## Connection of Line and Load Side

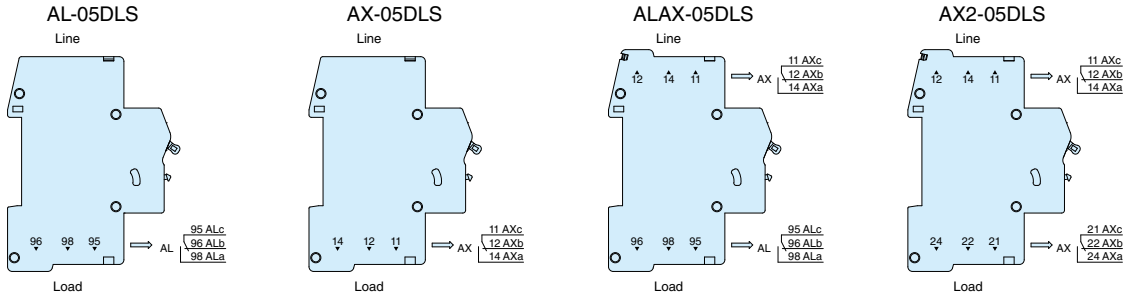

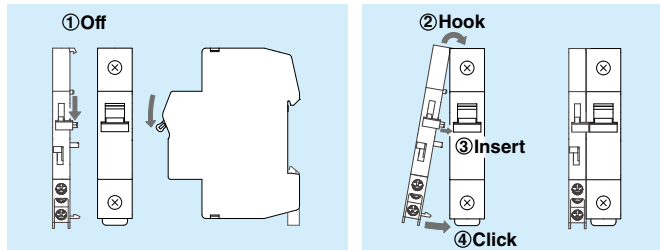

## Installation of Accessories (AX, AL, SHT)

### (1) Installation

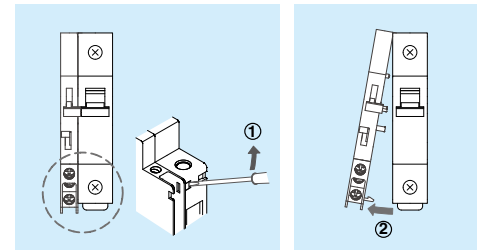

### (2) Removal



Frame (A)		30					
Model		CP30-BA			CP30-HU		
Image							
Number of poles		1	2	3	1	2	3
Rated insulation voltage Ui (V)		250			250		
Rated impulse withstand voltage Uimp (kV)		2.5			2.5		
Rated current (A)		0.1 0.25 0.3 0.5 1 2 3 5 7 10 15 20 30			0.1 0.25 0.3 0.5 1 2 3 5		
Rated short-circuit capacity (kA)	UL 1077 CSA C22.2 No.235	Rated voltage (V)	250			250	
		AC (V)	65	125	–	65	125
	IEC 60934 EN 60934 GB/T 17701 (Icn) (*9)	Rated insulation voltage Ui (V)	250			250	
		AC	2.5kA at 250V			2.5kA at 250V	10kA at 250V
	IEC 60947-2 EN 60947-2 (Icu/Ics)	Rated insulation voltage Ui (V)	250			250	
		AC	2.5kA at 230V			2.5kA at 230V	10kA at 230V
	Rated insulation voltage Ui (V)	250			250		
	DC	2.5kA at 60V	2.5kA at 120V	–	10kA at 60V	10kA at 120V	–
Current		AC/DC compatible (*11)			AC		
Reverse connection		Available			Available		
Pollution degree		2			2		
Selectivity category		A			A		
EMC environment condition (environment A or B)		Not Applicable			Not Applicable		
Rated ambient temperature (°C)		40 (T40)			40 (T40)		
Number of operating cycles	Without current	10,000			10,000		
	With current	6,000			6,000		
Operating characteristics		Instantaneous type (I); Medium type (M), (MD); Slow type (S), (SD); Fast type (F)			Instantaneous type (I); Medium type (M), (MD); Slow type (S)		
Mode of tripping		Instantaneous type (I): magnetic only [MO] Medium type (M), (MD) Slow type (S), (SD) : hydraulic-magnetic [HM] Fast type (F)			Instantaneous type (I): magnetic only (MO) Medium type (M), (MD) Slow type (S) : hydraulic-magnetic (HM)		
Dimensions [mm]	a	17.5	35	52.5	17.5	35	52.5
	b	73	73	73	73	73	73
	c	98	98	98	98	98	98
	ca	65	65	65	65	65	65
	ca	65	65	65	65	65	65
Method of operation		S-type (IEC 60934 / EN 60934)			S-type (IEC 60934 / EN 60934)		
Trip-free behaviour		Trip-free (IEC 60934 / EN 60934)			Trip-free (IEC 60934 / EN 60934)		
Mass (kg)	Screw	0.08	0.16	0.23	0.08	0.16	0.23
	SQ	0.09	0.17	0.25	–	–	–
Accessories	Retractable small terminal cover (TC-S)	● Standard IP20 (front, terminal covers closed) [Certified of TÜV] (*8)			● Standard IP20 (front, terminal covers closed) [Certified of TÜV]		
	Inertial delay (ID)	● (Medium, Slow type: AC only)			● (Medium, slow type: AC only)		
	Alarm switch (AL)	● (1c) (*7)			● (1c)		
	Auxiliary switch (AX)	● (1c) (*7)			● (1c)		
	Shunt trip (SHT)	● (for relay type) (*1)			● (for relay type) (*1)		
	Large terminal cover (TC-L)	● (*4), (*8), (*12)			● (*4)		
	Flushpanel mounting brackets (FP)	● (*4), (*8), (*12)			● (*4)		
	Back facing wiring terminal (BT)	● (*2), (*4), (*8), (*12)			● (*4)		
	Traneration conductor for accessories terminal (WB)	● (*8)			●		
Accessory terminal cover (TC)	● (*4), (*8)			● (*4)			
Connection	Main body	20A or less : Screw terminal M4 30A : Screw terminal M5 Male tab terminal 6.3mm (#250)(T) (*10) Spring clamp terminal (SQ) (*6)			Screw terminal M4		
	Alarm switch / Auxiliary switch / Shunt trip	Screw terminal M3.5 Spring clamp terminal (SQ) (*7)			Screw terminal M3.5		
Main body mounting method		Srface, IEC rail mounting Flush panel mounting (option)			Surface, IEC rail mounting Flush panel mounting (option)		
CE marking		EN 60934 : TÜV approval (*9) EN 60947-2 : Self-declaration (*3) EN 60947-3 : TÜV approval (*1)			EN 60934 : TÜV approval EN 60947-2 : Self-declaration (*3) EN 60947-3 : TÜV approval (*1)		
UKCA marking		EN 60934 : Self-declaration (*9) EN 60947-2 : Self-declaration (*3) EN 60947-3 : Self-declaration (*1)			EN 60934 : Self-declaration EN 60947-2 : Self-declaration (*3) EN 60947-3 : Self-declaration (*1)		
CCC		Certified (*3), (*9)			–		
Classification Society (☆ approval) (NK, LR, ABS, DNV)		–	☆ (*5) (NK) (*12)	☆ (*5) (NK) (*12)	–	–	–

Notes: \*1 In poles equipped with a voltage tripping device, the overcurrent tripping element is not provided. (relay-type voltage tripping). These models are not CCC certified. SHT 1P models comply with EN 60947-3 and IEC 60947-3. SHT 2P models are configured as 2P1E; therefore, the applicable DC rated voltage is the same as that specified for the 1P models above. SHT 3P models are configured as 3P2E and are suitable for both AC and DC applications. The applicable DC rated voltage corresponds to that specified for the 2P models above.  
\*2 For back-face wiring terminals, specify if it will be used with 30A, or 20A or less.  
\*3 UL (cURus), CCC, and CE, UKCA marking are displayed on standard products.  
\*4 It is recognition of UL (cURus), CCC, and TÜV.  
\*5 Support for special order  
\*6 A spring clamp terminal is only available for current 0.1 to 20A.  
\*7 In case of spring clamp terminal for AX and AL, specify if it will be used with the normal open contact or the normal close contact.  
\*8 In case of spring clamp terminal, it is not available.  
\*9 In case of spring clamp terminal rated 20A, it is not available.  
\*10 Male tab terminals are UL (cURus) only. Not subject to CCC, CE marking, UKCA marking. Retractable small terminal cover is not equipped.  
\*11 In the case of AC/DC shared models, tripping operating characteristics differ between AC and DC.  
\*12 Not supported when male tab terminal is selected for terminal shape.

Remarks: 1. When the instantaneous type (I) is used in an AC (sinusoidal) circuit, a buzzing sound may occur when the current is around 80% of the rated current; however, this does not affect performance. Therefore, please take this into consideration when selecting units for use in quiet environments.  
2. Due to the automatic reset structure, the handle does not indicate the trip position. However, only the alarm switch shows the structure that displays the "trip position" between ON and OFF.  
3. The standard small terminal cover supports IP20 from the front when the cover is closed. (TÜV certified)  
4. When using in a harmonic circuit, multiply the load current by 1.4 before selecting and checking the rated current of the circuit protector.

## Internal circuits and examples of application

Internal circuit	Operating characteristics						shunt trip
	Instantaneous type	Fast type	Medium type		Slow type		
	I	F (*1)	M	MD	S	SD (*1)	
Serial type 	●	●	●	●	●	●	-
Serial type with auxiliary switch 	●	●	●	●	●	●	-
Serial type with alarm switch (*2)(*3) 	●	●	●	●	●	●	-
Relay type shunt trip (with SHT) 	-	-	-	-	-	-	●

Notes:  
 \*1. CP30-HU is not available for fast type(F) and slow speed type(SD).  
 \*2. If the handle is held in the ON position, no alarm signal will be issued even if a trip occurs.  
 \*3. The alarm switch is reset when the breaker itself is reset or turned ON.

## ● Ratings of alarm switches (AL) and auxiliary switches (AX)

Classification		AC			DC			
		Voltage (V)	Current (A)		Voltage (V)	Current (A)		
Ratings of items other than those shaded in Table 1	For general load	Max.	125	3	1	50	1	0.5
		Min.	0.1A/15VAC			0.1A/15VDC		
	For minute load	Max.	125	0.5	-	30	0.5	-
		Min.	1mA/24VDC, 2mA/12VDC, 5mA/6VDC					
Ratings of items shaded in Table 1	For general load	Max.	125	3	-	30	0.5	-
		Min.	0.1A/15VAC			0.1A/15VDC		
	For minute load	Max.	125	0.1	-	30	0.1	-
		Min.	1mA/24VDC, 2mA/12VDC, 5mA/6VDC					

## ● Ratings of shunt trip (SHT) coils

Ratings		Rated operating voltage (V)		Time rating
100-200	Compatible with 100 to 200VAC and 100VDC			10 sec or less
24-48	Compatible with 24 to 48VDC			
Coil resistance, resistance and impedance (at25°C)				
Voltage (V)	Impedance for AC (Ω)		DC resistance for DC (Ω)	
100-200	2400		2100	
24-48	-		160	

Remarks: 1. The allowable range is 70% to 110% of the rated voltage.  
 2. The time rating is 10 seconds or less. Configure the circuit on which voltage will not be applied for more than 10 seconds.

## Internal accessories

### Auxiliary switch (AX)

Operates in conjunction with the main circuit operating mechanism to electrically retrieve the ON/OFF status of protector.

### Alarm switch (AL)

Operates in conjunction with the main circuit operating mechanism to electrically retrieve the tripping status of protector.

Remarks (1) When the handle of CP30-BA is constrained in the ON status, it does not issue the alarm signal even if it is tripped.  
 (2) The alarm switch will be reset when the body is reset or turned on.

### Shunt trip (SHT)

A parallel relay type protector, which can break the circuit instantaneously when receiving an external signal

### Inertial delay device

The inertial delay device is designed to avoid unnecessary operation caused by inrush current of transformer or lamp load. The device can withstand unrepeated one pulse of crest value 20 times higher than the rated current (pulse time = 8 ms). It can be added to circuits having high, medium and low speed operating characteristics. (It cannot be added to instantaneous or DC types.)

## ● Operation of auxiliary switch and alarm switch

	Protector status	Switch status
AX	Off or trip 	 AXa (open) / ALa (open) AXb (closed) / ALb (closed) AXc / ALc
AL	Off or ON 	
AX	ON 	 AXa (closed) / ALa (closed) AXb (open) / ALb (open) AXc / ALc
AL	Trip 	

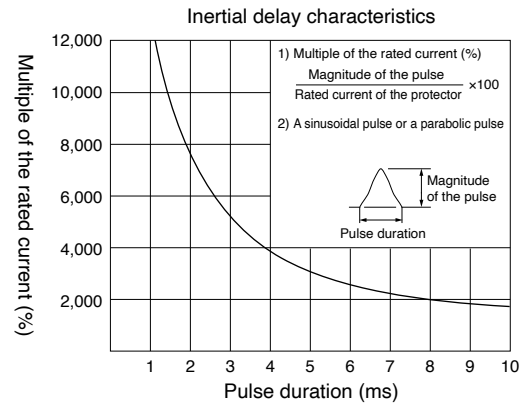

Table 1 List of numbers of internal accessories which can be fitted

AX			AX More than one				AL			AL+AX			SHT			AL+SHT or AX+SHT			AL+AX+SHT	
1P	2P	3P	1P	2P	3P	3P	1P	2P	3P	1P	2P	3P	1P	2P	3P	1P	2P	3P	3P	
○	○	○	○	○	○	○	●	●	●	○	○	○	■	■	■	○	○	○	○	○

Remark: 1. All accessories should be fitted on the internal accessory terminal block.

## Internal Impedance and Voltage Drop



The internal impedance of a circuit protector increases as the rated current decreases. Therefore, when using a circuit protector with a low rated current in power supply circuits or similar applications, please take the voltage drop into consideration.

**Internal Impedance Values Table**

Rated current (A)	DC resistance (Ω)		AC impedance 50/60Hz (Ω)	
	Medium type (M) Medium type with inertial delay (MD) Instantaneous type (I) Fast type (F) Slow type (S) Slow type with inertial delay (SD)	Medium type (M) Medium type with inertial delay (MD) Fast type (F) Slow type (S) Slow type with inertial delay (SD)	Instantaneous type (I)	
0.1	128	130	177	
0.25	21	22	26	
0.3	16	16	18	
0.5	5.5	5.6	6.5	
1	1.28	1.3	1.5	
2	0.35	0.36	0.40	
3	0.16	0.16	0.17	
5	0.056	0.057	0.069	
7	0.029	0.030	0.035	
10	0.015	0.016	0.019	
15	0.0066	0.0067	0.0093	
20	0.0049	0.0050	0.0052	
30	0.0026	0.0026	0.0028	

Remarks: 1. These values are for reference only and are not guaranteed.

## Installation and connection

Installation method	With screws	On IEC rails	With embedded fittings
Appearance			 Circuit protectors with AL, AX and/or SHT cannot be installed by this method.
CP30-BA	●	●	● <sup>*1</sup>
CP30-HU	●	●	●

\*1. In case of male tab terminal or spring clamp terminal, it is not available.



## Installation posture

The operating characteristics of electromagnetic (instantaneous) type circuit protectors are not affected by the installation posture. However, when installing a fluid electromagnetic (high, medium or low speed) type circuit protector, pay attention to the installation angle because the operating current value is changed under the influence of the gravity applied to the iron core in the oil dash pot.

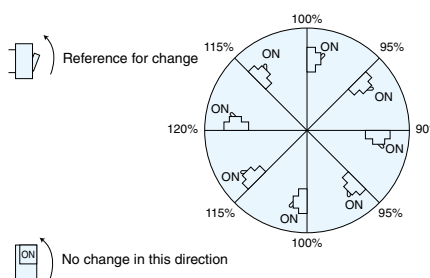
Generally, it is recommended to use the circuit protectors in the vertical direction.



## Electric wires which can be connected and applicable screw terminals

Classification	Shape of terminal	Electric wire size used (mm <sup>2</sup> )	Applicable screw terminals	Tightening torque (N • m)
Body	Threaded terminal (standard specification)  Cross recessed or slotted	20 A or less M4	R1.25-4 R1.25-5	M4 1.2±0.2
		30A M5	R2-4 R2-5	
			M3.5	R5.5-4 R5.5-5
		*8-5NS (made by JST)		
Alarm and auxiliary switch terminals	Wire retaining screw (square washer)  Cross recessed or slotted	0.25-1.65	R1.25-3.5	0.8±0.1
		1.04-2.63	R2-3.5	

\*Use the screw terminal 8-5NS made by JST.

## Low Voltage Air Circuit Breakers (AE-SW Series)

Frame (A)	630	1000	1250	1600	2000	2000	2500	3200	4000				
Model	AE630-SW	AE1000-SW	AE1250-SW	AE1600-SW	AE2000-SWA	AE2000-SW	AE2500-SW	AE3200-SW	AE4000-SWA				
Image													
Rated current (CT rating) In (A)	630 (*1)	1000	1250	1600	2000	2000 (*1)	2500	3200	4000				
Rated current setting Ir (A) (adjustable) (Reference ambient temperature 40°C) (For marine use 45°C)	315-346.5-378-409.5-441-472.5-504-535.5-567-598.5-630 (*1)	500-550-600-650-700-750-800-850-900-950-1000	625-687.5-750-812.5-875-937.5-1000-1062.5-1125-1187.5-1250	800-880-960-1040-1120-1200-1280-1360-1440-1520-1600	1000-1100-1200-1300-1400-1500-1600-1700-1800-1900-2000	1000-1100-1200-1300-1400-1500-1600-1700-1800-1900-2000 (*1)	1250-1375-1500-1625-1750-1875-2000-2125-2250-2375-2500	1600-1760-1920-2080-2240-2400-2560-2720-2880-3040-3200	2000-2200-2400-2600-2800-3000-3200-3400-3600-3800-4000				
Number of poles	3, 4 (*2)												
Rated insulation voltage Ui (V)	1000												
Rated current of neutral pole (A)	630	1000	1250	1600	2000	2000	2500	3200	4000				
Rated breaking capacity (kA symmetrical RMS)	IEC 60947-2, EN 60947-2		690VAC					75					
	JIS C 8201-2-1, Ann.1 Ann.2		600VAC					75					
	NK, LR, DNV-GL, BV, ABS, DNV, CCS		240-500VAC					85					
Ics = % Icu	100%												
Rated short-time withstand current (kA symmetrical RMS)	1s		65					75					
Suitability for isolation	Yes												
Reverse connection	Available												
Number of operating cycles (*7) (*8)	With rated current (690VAC In (*9))	5000			1500		1500		1000	500			
	Without rated current (*10)	10000			8000		8000		8000	5000			
Selectivity category	B												
Pollution degree	3												
EMC environment condition (environment A or B)	A (*12)												
Outline dimension (mm)	Fixed type	3-pole		410×340×290			410×475×290						
	4-pole	410×425×290			410×605×290								
Height (H) x width (W) x depth (D)	Drawout type	3-pole		430×300×375			430×435×375		430×439×375				
	4-pole	430×385×375			430×565×375			430×569×375					
Weight (kg) (Without Accessory) (*13)	Fixed type	3-pole	35	42	35	43	35	44	51	52	54	73	
	4-pole	42	42	42	43	43	43	54	64	64	67	92	
	Drawout type	3-pole	56	56	56	56	62	62	81	81	85	101	
	4-pole	70	70	70	70	75	75	101	101	106	106	127	
	Cradle only	3-pole			24			27		33		34	46
	4-pole			28				32		40		42	58
CE marking	Self-declaration												
UKCA marking	Self-declaration												
CCC (☆:Certified)	☆												
Marine approval (☆:Certified)	☆ (NK, LR, DNV, BV, ABS, CCS)												
Automatic tripping device	Electronic (effective value detection)												

- When the MCR is provided, the breaking capacity may be changed. See the catalog of Low Voltage Air Circuit Breakers, Y-0622.
- See the catalog of Low-voltage Air Circuit Breakers, Y-0622, for the details of the accessories.

- Notes:
- \*1 AE630-SW and AE2000-SW having low rating types are available. See the catalog of Low Voltage Air Circuit Breakers, Y-0622, for the details.
  - \*2 The 4-pole products do not have obtained the marine approval.
  - \*3 4 (HN) means the neutral poles current capacity is 50% of the rated current, for 4poles. 4 (FN) means the neutral poles current capacity is 100% of the rated current, for 4poles.
  - \*4 ( ) shows the value for 4P FN type.
  - \*5 Marine approval value is 138kA.
  - \*6 85kA for 690VAC and 600VAC.
  - \*7 The number of operating cycles is the guideline for the life of the open/close operation in the standard operation environment. These are not guaranteed values.

- \*8 Electrical operating cycles are included in mechanical operating cycles.
- \*9 This is the guideline for the life of the open/close operation when periodic inspection and maintenance are performed and consumable parts are not replaced.
- \*10 This is the guideline for the life of the open/close operation when periodic inspection and maintenance are performed and consumable parts are replaced.
- \*11 This value is max. operating cycle for just ACB body without any accessories. (The max. operating cycles for the accessories like AX, MD, CC, SHT and UVT are half of this value.)
- \*12 This product is designed on the basis of environment A. When used under environment B, it might cause electromagnetic interference, and the user would be asked to do countermeasures to reduce these interference.
- \*13 These weights include an electronic relay, but don't include other accessories.

## Features

- **Higher reliability by High operating durability (Mechanical)**
- **Increase of rated short-time withstand current**  
Combination of the Electronic trip relay (ETR) with MCR (\*1) enables increase of the choice coordination range.
- **Applicability to increase and decrease of load and improvement of protection coordination**  
The electronic tripping system enables detailed setting of tripping characteristics. The system uses RMS detection resistant to distorted waves.
- **More improved Electronic trip relay (ETR) and transmission functions**  
To flexibly meet various requirements, functions suitable for purposes can be selected effectively. In addition, improved measuring functions are provided, so that the circuit breakers are applicable to MODBUS transmission and helpful in establishing various electrical circuit measurement monitoring systems and energy-saving systems in combination with measuring display unit breakers.

- Notes: \*1 MCR is an abbreviation for marking current release. It has INST characteristic only when the circuit breaker in the OFF state turns ON (closes). The circuit breaker will lose the INST characteristic after closing, and it will have LTD and STD characteristics.

## Various connections

Various connections for panel structures are available. (See the following figure.)

## Connections

Connections Model	Horizontal	Vertical (*1) (VT)	Front (FT)	Vertical terminal adapter (VTA)	Front terminal adapter (FTA)
Fixed type (FIX)	(Standard)	FIX-VT	-	(FIX-VTA)	(FIX-FTA)
Drawout type (DR)	(Standard)	(DR-VT)	(DR-FT)	(DR-VTA)	(DR-FTA)

- Notes: \*1 For AE2000-SWA, AE4000-SWA, AE4000-SW, AE5000-SW and AE6300-SW models, vertical terminal only is available.

## Low Voltage Air Circuit Breakers (AE-SW Series)

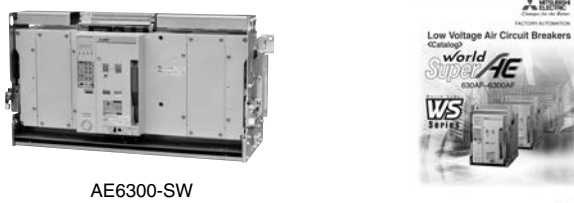
Frame (A)	4000	5000	6300
Model	AE4000-SW	AE5000-SW	AE6300-SW
Image (Reference)	 <p style="text-align: center;">AE6300-SW (Drawout type)</p>		
Rated current (CT rating) In (A)	4000	5000	6300
Rated current setting Ir (A) (adjustable) (Reference ambient temperature 40°C) (For marine use 45°C)	2000-2200-2400-2600-2800-3000-3200-3400-3600-3800-4000	2500-2750-3000-3250-3500-3750-4000-4250-4500-4750-5000	3150-3465-3780-4095-4410-4725-5040-5355-5670-5985-6300
Number of poles	3, 4 (HN, FN) (*2) (*3)		
Rated insulation voltage Ui (V)	1000		
Rated current of neutral pole (A)	2000 (4000) (*4)		
Rated breaking capacity (kA symmetrical RMS)	IEC 60947-2, EN 60947-2		
	JIS C 8201-2-1 Ann.1 Ann.2		
Rated short-time withstand current (kA symmetrical RMS)	690VAC		
	600VAC		
Rated short-time withstand current (kA asymmetrical RMS)	240-500VAC		
	Ics = % Icu		
Rated short-time withstand current (kA symmetrical RMS)	1 s		
Suitability for isolation	Yes		
Reverse connection	Available		
Number of operating cycles (*7) (*8)	1000		
Without rated current (*10)	-		
Without rated current (*10)	10000 (3P) / 5000 (4P)		
Selectivity category	B		
Pollution degree	3		
EMC environment condition (environment A or B)	A (*12)		
Outline dimension (mm)	Fixed type	3-pole	
	4-pole	414x874x290	
Height (H) x width (W) x depth (D)	Drawout type	3-pole	
	4-pole	414x1004 (1134) x290 (*4)	
Weight (kg) (without Accessory) (*13)	Fixed type	3-pole	
	4-pole	141	
	Drawout type	3-pole	
	4-pole	159 (179) (*4)	
	Cradle only	3-pole	
	4-pole	113 (127) (*4)	
CE marking	Self-declaration		
UKCA marking	Self-declaration		
CCC (☆:Certified)	☆		
Marine approval (☆:Certified)	☆ (NK, LR, DNV, BV, ABS)		
Automatic tripping device	Electronic (effective value detection)		

### ■ Electronic trip relay (ETR) Type code

● **Main setting module**

WS1, WB1, WM1, WF1	AE6300-1600-SW, AE2000-3200-SW, AE4000-SW
WS2, WB2, WM2, WF2	AE2000-SWA, AE4000-SWA, AE5000-SW
WS3, WB3, WM3, WF3	AE6300-SW

WS : General use  
WM : Generator protection use  
WB : INST/MCR only  
WF : Protective coordination use

● **Optional setting module**

G1: Ground fault protection  
N5: Neutral pole 50% protection  
E1: Earth leakage protection  
AP: 2nd Additional Pre-alarm  
NA: Without optional setting

● **ETR Auxiliary Equipment**

Temperature alarm (TAL)  
 MCR switch (MCR-SW)

For the details of the characteristics, alarm contact output and expanded functions of the ETR, see the catalog of Low Voltage Air Circuit Breakers, Y-0622.

● **Power supply**

P1: 100-240VAC-DC  
P2: 24-60VDC  
P3: 100-240VAC / 100-125VDC with output contact  
P4: 24-60VDC with output contact  
P5: 100-240VDC with output contact (SSR)

● **Additional function**

Extension module (EX1) **Network**

Display (DP1)  
 Display onto panel board (DP2)  
 VT unit (VT)

Extension module (EX2)\* **Network**

Display (DP1)  
 Display onto panel board (DP2)

\* Cannot be used with WF relays.

Wire system (when EX1 or EX2 is specified)

EX1 / EX2

3φ3W  
 3φ4W  
 Normal connection  
 Reverse connection

Normal connection: Upper terminal is connected to power supply.  
Reverse connection: Lower terminal is connected to power supply.

\*The display is optional.



## Earth Leakage Relays

Model		Interchangeable leakage relays (*1)													
		Electrical self-hold type				Mechanical self-hold type				Harmonic surge ready					
		NV-ZBA		NV-ZSA		NV-ZHA		NV-ZLA							
Model name of ZCT combined (*5)	Hole diameter mm														
	15	ZT15B	-	ZT15B	-	ZT15B	-	ZT15B	-						
	30	ZT30B	-	ZT30B	-	ZT30B	-	ZT30B	-						
	40	ZT40B	-	ZT40B	-	ZT40B	-	ZT40B	-						
	60	-	ZT60B	-	ZT60B	-	ZT60B	-	ZT60B	-					
	80	-	ZT80B	-	ZT80B	-	ZT80B	-	ZT80B	-					
100	-	ZT100B	-	ZT100B	-	ZT100B	-	ZT100B	-						
Image															
Phase line type		3φ4W, 3φ3W, 1φ3W, 1φ2W													
Control voltage VAC		120 • 240 selectable				120 • 240 selectable 240 • 415 selectable (*7)				-					
UL/JIS (*2) UL/CE (*3) (*7)		-				-				120 • 240 selectable 240 • 440 selectable					
JIS	High speed type	Rated sensitivity current mA	100 • 200 • 500 selectable		100 • 200 • 500 selectable		100 • 200 • 500 selectable		100 • 200 • 500 selectable		-				
		Max. operating time (s)	0.1				0.1								
	Delay type	Rated sensitivity current mA	100 • 200 • 500 selectable				100 • 200 • 500 selectable (200 • 500 • 1000 selectable)				-				
		Operating time (s) (*4)	0.3 • 0.8 • 1.6 selectable				0.3 • 0.8 • 1.6 selectable				-				
Inertial non-operating time (s) or longer than (s)		0.1 • 0.5 • 1.1				0.1 • 0.5 • 1.1				-					
UL/JIS	High speed type	Rated sensitivity current mA	-				-				30 50				
		Max. operating time (s)	-				-				0.1				
	Delay type	Rated sensitivity current mA	-				-				100 • 200 • 500 selectable				
		Max. operating time (s) (*4)	-				-				0.1 • 0.45 • 1.0 selectable				
Inertial non-operating time (s) or longer than (s)		-				-				- • 0.1 • 0.5					
UL/CE	High speed type	Rated sensitivity current mA	-				-				30 • 50 • 100 selectable				
		Max. operating time (s) at 5Δn	-				-				0.04				
	Delay type	Rated sensitivity current mA	-				-				100 • 300 • 500 selectable 300 • 500 • 1000 selectable				
		Max. operating time (s) at 2Δn (*4)	-				-				0.45 • 1.0 selectable				
Inertial non-operating time (s) at 2Δn		-				-				0.1 • 0.5					
Earth leakage indication		Electric type (LED)				Mechanical type (button)				Electric type (LED)					
Resetting method		Push button or control power switch off				Push button (combined with earth leakage indicator)				Push button or control power switch off					
Built-in contact	Configuration		1c				1a1c				1a1c				
	Continuous current capacity A		5				5				5				
	Contact capacity A		cosφ=1	cosφ=0.4 L/R=0.007		cosφ=1		cosφ=0.4 L/R=0.007		cosφ=1		cosφ=0.4 L/R=0.007			
				120VAC	5	2	120VAC	5	3	120VAC	5	2	120VAC	5	3
			240VAC	5	2	240VAC	3	2	240VAC	5	2	240VAC	3	2	
			24VDC	5	2	415VAC	2	1	24VDC	5	2	480VAC	1	1	
30VDC			4		3		Use auxiliary relay for 440VAC contact.		30VDC		3		3		
100VDC			0.4		0.4				100 • 300 • 500 selectable 300 • 500 • 1000 selectable		100 • 300 • 500 selectable 300 • 500 • 1000 selectable				
200VDC		0.2		0.2				0.45 • 1.0 selectable		0.45 • 1.0 selectable					
Connection		Front		●Clamp terminal				●Clamp terminal							
Rear		-				●Clamp terminal				●Clamp terminal					
Standard attachment (Front connection)		Mounting screw													
Mass kg		0.3				0.4				0.4					
Relay		● (TC-ZBA)				● (TC-ZSA)				● (TC-ZSA) (*6)					
External accessories		Terminal cover		● (DIN-ZBA)				-				-			
Mounting hook for IEC 35mm rail (DIN rail) Fixture		● (DIN-ZBA)				-				-					
Max. consumption VA		3													
Conforming standard	UL standard (UR certified)	-				-				UL1053 Recognized component (File No.E196562)					
	European CE marking	-				-				Declaration for conformity IEC 60947-2 EN 60947-2					
	UKCA marking	-				-				Declaration for conformity IEC 60947-2 EN 60947-2					

Notes: \*1 Interchangeable leakage relays can be easily combined with other relays and our ZCT. However, products with 30mA sensitivity (excluding NV-ZHA/ZLA) can only be used in combination with ZT15B, ZT30B and ZT40B.  
 \*2 Indicates the UL-standard control voltage. UL (cURus) and JIS standards are indicated together. For JIS voltage indications, 100•200V changeover is 120•240V changeover, 200•415V changeover is 240•440V changeover, and 460V and 480V are described together. When ordering, specify "UL/JIS".  
 \*3 Indicates the UL-standard control voltage. UL (cURus) and CE•UKCA standards are indicated together. For CE•UKCA voltage indications, 120•230V changeover is 120•240V changeover, 230•440V changeover is 240•440V selectable, which are described together. When ordering, specify "UL/CE".  
 \*4 When operating times are 0.3 and 0.45sec, 0.8 and 1.0sec and 1.6sec, the relay operates between 0.15 and 0.45sec, 0.6 and 1.0sec and 1.2 and 2.0sec, respectively.  
 \*5 Can be combined with an interchangeable ZCT equipped with a primary conductor. (Not UL-certified) Refer to the next page for details.  
 \*6 Not UL-certified.  
 \*7 This control voltage conforms to JIS C8374.

Remarks: 1. Relays with rates shown in parentheses are special-order.  
 2. For models with adjustable specifications, the rate sensitivity current and operation time are set up to their maximum values upon delivery.  
 3. NV-ZBA/ZSA

Control voltage	Available voltage range	Example of applicable circuit voltage
120V	80-132V	100 • 110V • 120V
240V	160-264V	200 • 220 • 230 • 240V
415V	320-484V	380 • 400 • 415 • 440V

### 4. NV-ZHA/ZLA

Control voltage	Available voltage range	Example of applicable circuit voltage
120V	80-132V	100 • 110V • 120V
240V	160-264V	200 • 220 • 230 • 240V
440V	304-484V	380 • 400 • 415 • 440V
480V	368-528V	460 • 480V

Canada CSA Standard  
C22.2 No.144

## Interchangeable ZCT

Type	ZT15B	ZT30B	ZT40B	ZT60B	ZT80B	ZT100B	
Aperture diameter (mm)	15	30	40	60	80	100	
Mass (kg)	0.2	0.4	0.6	2.0	2.6	3.3	
Rated short time current (kA)	50 (peak value)						
Dimensions (mm)	a	48	68	85	140	160	185
	b	52	52	52	90	90	90
	c	70	90	100	150	169	190
	d	25	50	50	100	100	100
	e	40	40	40	70	70	70

## ZCT aperture diameter and wire size

	ZCT aperture diameter (mm)	15	30	40	60	80	100
		Max. 600V rated wire size in mm <sup>2</sup> (current in amperes)					
1φ2w	Polyvinyl-chloride insulated wire	14 (88)	60 (217)	150 (395)	325 (650)	600 (992)	800 (1185)
	Cross-linked polyethylene insulated cable	2 (33)	38 (190)	60 (260)	250 (655)	400 (870)	600 (1140)
1φ3w 3φ3w	Polyvinyl-chloride insulated wire	8 (61)	38 (162)	100 (298)	250 (556)	500 (842)	725 (1095)
	Cross-linked polyethylene insulated cable	2 (33)	22 (135)	60 (260)	200 (560)	325 (760)	600 (1140)
3φ4w	Polyvinyl-chloride insulated wire	8 (61)	38 (162)	100 (298)	150 (395)	325 (650)	600 (992)
	Cross-linked polyethylene insulated cable	—	14 (105)	38 (190)	100 (365)	250 (655)	400 (870)

## Interchangeable ZCTs with primary conductors

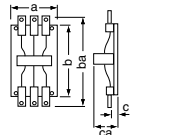
Type	ZTA600A	ZTA1200A	ZTA2000A	
Number of poles	3			
Rated voltage (VAC)	600			
Rated short time current (kA)	100 (peak value)			
	a	227	227	360
	b	256	298	250
	ba	366	444	594
	c	42	78.5	79.5
	ca	125	176	214
Mass (kg)	6.5	11	27	

## ELRs with a ZCT with primary conductors

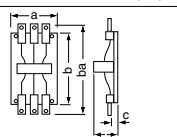
Frame (A)	600	1200	2000	3200	
Type	ZBA	Interchangeable ELR and interchangeable ZCTs with primary conductors			
	ZSA				
	ZHA				
	ZLA				
Number of poles	3				
Rated voltage (VAC)	600				
Rated short time current (kA)	100 (peak value)				
	a	227	227	360	490
	b	256	298	250	320
	ba	366	444	594	868
	c	42	78.5	79.5	111
	ca	125	176	214	290
Mass (kg)	6.5	11	27	54	

Specification of ELRs	Type	Control voltage (VAC)	Rated current sensitivity (mA)	Max. operating time (s)	Inertial non-operating time (s)
		High-speed type	ZBA 120 • 240 (*1)	100 • 200 • 500 (*1)	0.1
ZSA 120 • 240 (*1) 240 • 415 (*1)	100 • 200 • 500 (*1)				
Time-delay type (High-speed • Time-delay type)	ZBA	120 • 240 (*1)	100 • 200 • 500 (*1)	0.3 • 0.8 • 1.6 (*1)	0.1 • 0.5 • 1.1
	ZSA	120 • 240 (*1) 240 • 415 (*1)	100 • 200 • 500 (*1) (200 • 500 • 1000 (*1))	0.3 • 0.8 • 1.6 (*1)	0.1 • 0.5 • 1.1
	ZHA	120 • 240 (*1) 240 • 440 (*1)	100 • 200 • 500 (*1)	0.1 • 0.45 • 1.0 (*1)	— • 0.1 • 0.5
	ZLA	120 • 240 (*1) 240 • 440 (*1) 480	100 • 200 • 500 (*1) 100 • 300 • 500 (*1) 300 • 500 • 1000 (*1)	0.45 • 1.0 (*1) (at 2IΔn)	0.1 • 0.5 (at 2IΔn)
			100 • 200 • 500 (*1)	0.1 • 0.45 • 1.0 (*1)	— • 0.1 • 0.5
			100 • 300 • 500 (*1) 300 • 500 • 1000 (*1)	0.45 • 1.0 (*1) (at 2IΔn)	0.1 • 0.5 (at 2IΔn)

Note: \*1 Selectable.

# MEMO

---

---

2

# 3

## Special-purpose Breakers

1) Mag Only (Instantaneous Tripping Circuit Breakers) .....	62
2) DC MCCBs and DSN Switches .....	63
3) 400Hz MCCBs .....	63
4) MCCB and ELCB for special environment .....	64

## 1. Mag Only (Instantaneous Tripping Circuit Breakers)

Standard magnetic trip current

Fixed	NF32-SV	AC-DC	Rated current x 10 (AC) (DC)
	NF63-CV/SV/HV	AC-DC	
	NF125-CV/SV/HV	AC-DC	
	NF400-CW/SW NF630-CW/SW	AC-DC	
Adjustable	NF800-SEW	AC	High: Rated current x 10 Low: Rated current x 2
	NF800-SDW	DC	High: 8000A   Low: 3200A
	NF1000-SEW NF1250-SEW	AC	High: Rated current x 10 Low: Rated current x 2
	NF1600-SEW	AC	High: Rated current x 10 Low: Rated current x 2
	NF1250-SDW NF1600-SDW	DC	High: 8000A Low: 3200A

Remarks: 1. The size, weight, accessories, etc., are all identical to the same-designation C, S and H series breakers.

### ● Minimum and max magnetic trip current

Fixed

Model	Rated current(A)	Current	Instantaneous tripping current(A)		Model	Rated current(A)	Current	Instantaneous tripping current(A)		
			min-max	standard				min-max	standard	
NF32-SV	3	AC-DC	9-300	30	NF250-CV NF250-SV	125	AC-DC	375-3150	1250	
	5		15-300	50		150		450-3150	1500	
	10		30-300	100		175		525-3150	1750	
	15		45-300	150		200		600-3150	2000	
	20		60-300	200		225		675-3150	2250	
	30		90-300	300		250		750-3150	2500	
NF63-CV NF63-SV NF63-HV	32		96-320	320	125	NF250-HV		125	375-3150	1250
	10		30-500	100	150			150	450-3150	1500
	15		45-500	150	175			175	525-3150	1750
	20		60-500	200	200			200	600-3150	2000
	30		90-500	300	225			225	675-3150	2250
	40		120-500	400	250			250	750-3150	2500
NF125-CV	50		150-500	500	250	NF400-CW		250	900-4000	2500
	60		180-600	600	300			300	900-4000	3000
	63		189-630	630	350			350	1050-4000	3500
	60		180-1600	600	400			400	1200-4000	4000
	75		225-1600	750	250			250	900-5600	2500
	100		300-1600	1000	300			300	900-5600	3000
NF125-SV	125	600-1600	1250	350	NF630-CW	350	1050-5600	3500		
	15	60-1600	150	400		400	1200-5600	4000		
	20	120-1600	200	500		500	2000-6300	5000		
	30	120-1600	300	600		600	2400-6300	6000		
	40	200-1600	400	630		630	2520-6300	6300		
	50	200-1600	500	500		500	2000-5000	5000		
NF125-HV	60	400-1600	600	600	NF630-SW	600	2400-6000	6000		
	75	400-1600	750	630		630	2520-6300	6300		
	100	400-1600	1000							
	125	600-1600	1250							
	15	60-1600	150							
	20	120-1600	200							

Adjustable(tripping current)

Model	Current	Max	Rated current(A)	Instantaneous tripping current(A)			
				Lo	2	3	Hi
NF800-SDW	DC	800	(700)	2800	4200	5600	7000
			800	3200	4800	6400	8000
1000		1000	3200	4800	6400	8000	
1250		1250					
NF1600-SDW		1600	1600				

Adjustable(rated current)

Model	Current	Rated current(A)	Instantaneous tripping current(%)
NF800-SEW	AC	400 450 500 600 700 800	200 250 300 350 400 500 600 700 800 1000
NF1000-SEW		500 600 700 800 900 1000	
NF1250-SEW		600 700 800 1000 1200 1250	
NF1600-SEW		800 1000 1200 1400 1500 1600	

## 2. DC MCCBs and DSN Switches

Breaking is more difficult with direct currents because the current value never reaches zero. While ordinary DC breakers are suitable for low voltages, special-voltage DC breakers are recommended for voltages in excess of 250VDC. Breakers for 550V are all 4-pole models. The size, shape, drilling plan, accessories, etc., are all identical to the S Series breakers with the same designations.

Wiring diagram for DC usage.

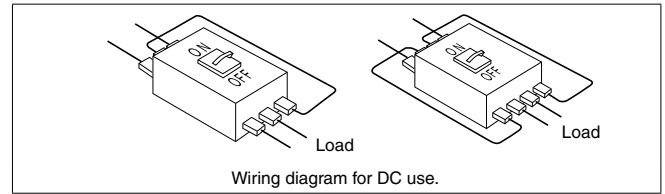

Remark: 1. The tripping characteristics will change if the wiring differs from the one shown here.

Model	NF63-SV		NF125-SV		NF250-SV		NF400-SW		NF630-SW		NF800-SDW		NF1250-SDW		NF1600-SDW	
Number of poles	3	4	3	4	3	4	3	4	3	4	3	4	3		3	4
Rated voltage (VDC)	400	550	440	550	500	600	500	600	500	600	500	600	500	600	500	600
Rated breaking capacity (kA) IEC 60947-2 (Icu/Ics)	2/2		10/10		20/20		40/40		40/40		40/40		40/20	20/20	40/20	40/20

Remark: 1. Time constant: 10ms or below.  
2. NF1250-SDW 3P and NF1600-SDW 3P/4P are Mag Only (Instantaneous Tripping Circuit Breakers).

### ●DC side

These breakers are designed as thyristor-Leonard system DC side breakers. They protect the thyristor from short circuiting when there is a power or

communication failure (Mag Only breakers can also be used for this purpose). Use these breakers in combination with fast fuses for even greater protection.

Model	NF125-SV		NF250-SV		NF400-SW		NF630-SW		NF800-SDW		NF1250-SDW		NF1600-SDW	
Number of poles	2	3	2	3	2	3	2	3	2	3	2	3	2	3
Rated voltage (VDC)	250	440	300	500	250	480	250	480	250	480	250	480	250	480
Rated breaking capacity (kA) IEC 60947-2 (Icu/Ics)	40/40	10/10	20/20		20/20		20/20		20/20		20/20		20/20	
Instantaneous trip current min.)	3 times rated current		3 times rated current		900A		1000A		1400A		2500A		3200A	

### ●DSN switches

These are standard MCCBs without the automatic tripping element. The tripping capacity is about six times the rated current.

The appearance, size, drilling plan and available accessories are all identical to similar standard S and C Series MCCBs.

Model	DSN63-CV		DSN125-CV		DSN250-CV		DSN400-CW		DSN630-CW		DSN800-CW	
Rated current (A)	63		125		250		400		630		800	
Number of poles	2	3	2	3	2	3	2	3	3		3	
Rated voltage (AC/DC)	500/250		500/250		500/250		600/250		600/250		600/250	
Max. switching current (AC/DC)	378/155		750/310		1500/625		2400/1000		3780/1575		4800/2000	

Model	DSN32-SV	DSN63-SV	DSN125-SV	DSN125-SGV	DSN160-SGV	DSN250-SV	DSN250-SGV	DSN400-SW	DSN630-SW	DSN800-SW	DSN1000-SW	DSN1250-SW	DSN1600-SW
Rated current (A)	32	63	125	125	160	250	250	400	630	800	1000	1250	1600
Number of poles	2   3	2   3	2   3   4	2   3   4	2   3   4	2   3   4	2   3   4	2   3   4	3   4	3   4	3   4	3   4	3   4
Rated voltage (AC/DC)	500/250	500/250	690/250	690/300	690/300	690/250	690/300	690/250	690/250	690/250	690/250	690/250	690/250
Max. switching current (AC/DC)	192/80	378/155	750/310	750/315	960/400	1500/625	1500/625	2400/1000	3780/1575	4800/2000	6000/2500	7500/3125	9600/4000

## 3. 400Hz MCCBs

Standard MCCBs cannot be used in 400Hz circuits. When standard MCCBs are used in high-frequency circuits (eq. 400Hz), the instantaneous characteristics are shifted higher. The 400Hz MCCB is recommended for use in 400Hz circuits.

### ●Specifications

The appearance, size, rated interrupting capacity, drilling plan, accessories, etc., are all identical to the standard S and H Series breakers of the same designation.

Model	NF125-SV	NF125-HV	NF250-SV	NF250-HV	NF400-SW	NF400-SEW	NF630-SW (*)	NF630-SEW	NF800-SEW	NF1250-SEW	NF1600-SEW
Rated current (A)	16, 20, 32, 40, 50, 63, 80, 100	16, 20, 32, 40, 50, 63, 80, 100	125, 150, 175, 200	125, 150, 175, 200	225, 250, 300, 350	200-350 adjustable	400, 500	300-500 adjustable	400-600 adjustable	600-800 adjustable	800-1200 adjustable
Number of poles	2   3   4	2   3   4	2   3   4	2   3   4	2   3   4	3   4	3   4	3   4	3   4	3   4	3   4
Rated insulation voltage (V)	690										
Rated breaking capacity (kA)	8/8	10/8	8/8	10/8	10/10	10/10	10/10	10/10	10/10	25/13	25/13
IEC 60947-2 (Icu/Ics)	18/18	30/23	30/30	50/38	30/30	30/30	42/42	42/42	42/42	65/33	65/33
440VAC	25/25	50/38	36/36	65/65	42/42	42/42	42/42	42/42	42/42	85/43	85/43
400VAC	30/30	50/38	36/36	75/75	45/45	50/50	50/50	50/50	50/50	85/43	85/43
230VAC	50/50	100/75	85/85	100/100	85/85	85/85	85/85	85/85	85/85	125/63	125/63

Note: \*1 Instantaneous trip current : Rated current x 14 (Fix)

## 4. MCCB and ELCB for special environment

Our MCCBs and ELCBs are manufactured based on the normal operating conditions. When using our MCCBs and ELCBs under different conditions, MCCBs and ELCBs for special environment are also available.

### ● Normal operating conditions

- Ambient temperature.....10°C~40°C  
Average temperature does not exceed 35°C in 24°C hours  
Current-temperature compensation ratio when exceeding 40°C  
50°C 0.9 times  
60°C 0.7 times
- Relative humidity.....Below 85% and no condensation
- Altitude.....Below 2,000m
- Atmosphere.....No excessive water vapor, oil vapor, smoke, dust, salt, corrosive substance, impact and vibration

Special environment		Special purpose	Specification	Model	
				MCCB	ELCB
Low temp.	Cold storage warehouses	Low temp. breakers	Operation characteristics change under low temp. environment.	NF-C/S/H series (*1, *2)	NV32-SV NV63-CV/SV/HV NV125-CV/SV/HV NV250-CV/SV/HV
High temp. High humid.	Chemical plants	Tropical treatment breakers	Under high humidity, withstand voltage and other electrical performance may be reduced. Moisture proof, mildew proof and corrosion resist breakers are available.	NF-C/S/H series (*3, *4, *5, *6, *7)	NF-C/S/H series (*3, *4, *5, *6, *7)
Corrosive gas Salt	Petrochemical plants	Corrosion resist breaker	In case using breakers in environment filled with corrosive gas and salt, breaker with corrosion resisted boxes are recommended to use. If corrosion gas concentration is under standard value, corrosion resisted breaker can also be used. Gas concentration limit for standard breakers: H <sub>2</sub> S(0.01ppm), SO <sub>2</sub> (0.05ppm) HCl(0.05ppm), Cl <sub>2</sub> (0.01ppm) NH <sub>3</sub> (0.25ppm)	NF-C/S/H series (*3, *4, *5, *6, *7)	NF-C/S/H series (*3, *4, *5, *6, *7)
Dust	Cement factory	Boxed breakers	In case dusty environment, boxed breakers are recommended to use. Refer to page 130. If breakers are to be installed in explosion proof case, use less ammonia molded breakers.		

- Notes: \*1 SHT and UVT are not applicable.  
\*2 Electronic breakers are not applicable.  
\*3 250A frame electronic breakers are not applicable.  
\*4 AL, AX, SHT, UVT, TBL for 1000, 1200A frame ELCBs are not applicable.  
\*5 ELCBs for special voltage are not applicable.  
\*6 AL and AX for minute load are not applicable.  
\*7 UVT are not applicable.

# 4

## Selection

<b>1 Construction and Operation</b>	<b>66</b>
1) Construction of MCCB.....	66
2) Construction of ELCB .....	68
<b>2 Selection of MCCB and ELCB</b>	<b>69</b>
1) Selecting Procedure.....	69
2) Features and Performance .....	70
3) Current-carrying Capacity and Operating Temperature .....	72
4) Application of Circuit Breaker According to Breaking Capacity .....	74
5) Selection of Circuit Breaker for Electric Lamp or Heater Circuit .....	75
6) Selection of Circuit Breaker for Motor Branch Circuit .....	77
7) Selection of Motor Protection Breaker .....	79
8) Selection of Circuit Breaker for Inverter Circuit .....	80
9) Selection of Circuit Breaker for Transformer Primary Side .....	81
10) Combination for Selective Breaking.....	85
11) Combinations for Cascade Breaking .....	87
12) International Standard Conformance List .....	89
<b>3 Selection of ELCB</b>	<b>92</b>
1) Electric Shock Protection .....	92
2) ELCB Grounding Method .....	93
3) Rated Voltage and Number of Poles .....	94
4) Earth Fault Protection Coordination and Combination of Devices .....	95

## 1. Construction of MCCB

### ● Arc-Extinguishing Device

MCCBs feature excellent arc-extinguishing performance by virtue of the optimum combination of grid gap, shape, and material.

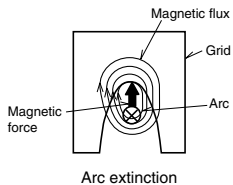

### ● Switching Mechanism

The contacts open and close rapidly, regardless of the moving speed of the handle, minimizing contact wear and ensuring safety.

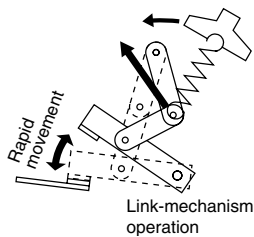

### ● Trip Button (Push to Trip)

Enables tripping mechanically from outside, for confirming the operation of the accessory switches and the manual resetting function.

### ● Adjustable Instantaneous Tripping Current

On electronic molded case circuit breakers, the instantaneous tripping current can be adjusted only by turning the knob. Therefore, optimum characteristics for load can be obtained.

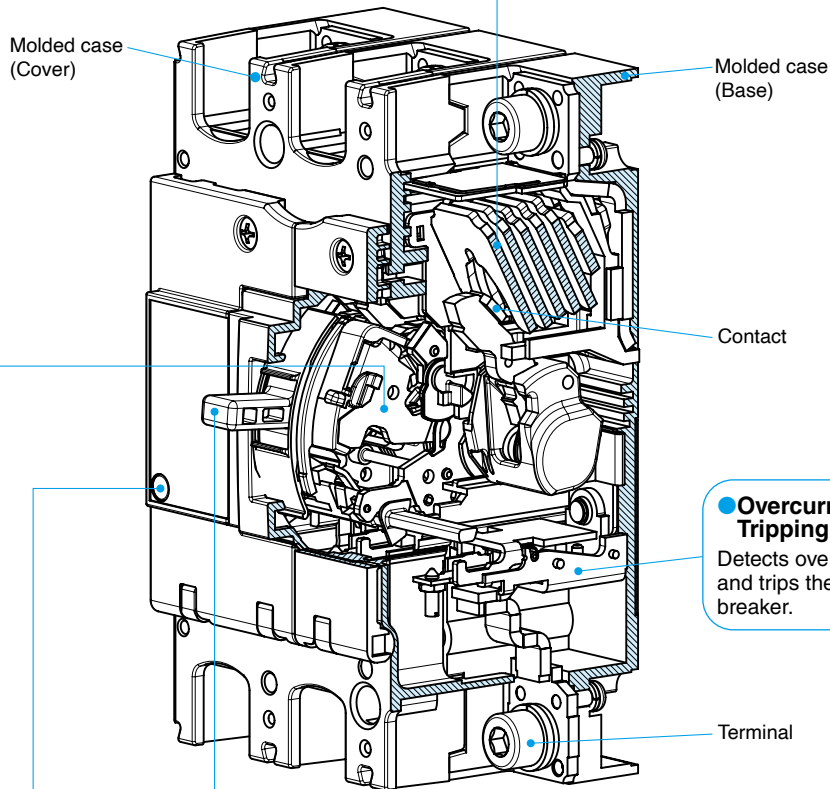
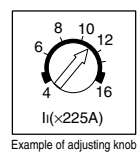

Fig. 4.1 Construction

### ● Overcurrent Tripping Device

Detects overcurrent and trips the circuit breaker.

### ● Handle

#### 1. Trip indication

The automatically tripped condition is indicated by the handle in the center position between ON and OFF, the yellow (or white) line cannot be seen in this position.

#### 2. Resetting

Resetting after tripping is performed by first moving the handle to the OFF position to engage the mechanism, then returning the handle to ON to reclose the circuit.

#### 3. Trip-Free

Even if the handle is held at ON, the breaker will trip if an overcurrent flows.



Handle indication

#### 4. Contact On Mechanism

Even in the worst case in which welding occurs owing to an overcurrent, the breaker will trip and the handle will maintain to ON, indicating the energizing state.

## 4-pole Breaker

- The 4-pole breaker is designed for 3-phase 4-wire circuits. A neutral pole without an overcurrent tripping element is provided at the right end. The construction and operation are the same as class S, H and U breakers. (Electronic molded case circuit breakers with frame size of 1600A or less have overcurrent tripping elements on the neutral poles.)
- Since the four poles are simultaneously opened and closed, the user will not fail in turning on the neutral pole or carelessly open the pole. (The standard construction is designed to close the neutral pole earlier and open it later than the voltage pole.)

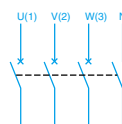

Fig. 4.2 4-pole Breaker (NF250-SV)

## Over-current Tripping Devices

### Thermal-Magnetic Type

( NF32-SV, NF63-CV/SV/HV, NF125-CV/SV/HV, NF250-CV/SV/HV )  
( NF400-CW/SW, NF630-CW/SW, NF800-SDW, etc. )

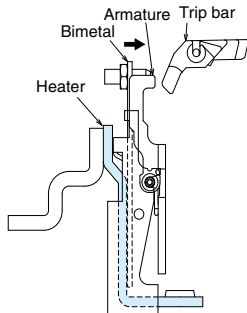

Fig. 4.3

1. Time-Delay Operation  
An overcurrent heats and warps the bimetal to actuate the trip bar.
2. Instantaneous Operation  
If the overcurrent is excessive, the armature is attracted and the trip bar actuated.

### Thermal-Magnetic Type (NF1250-SDW)

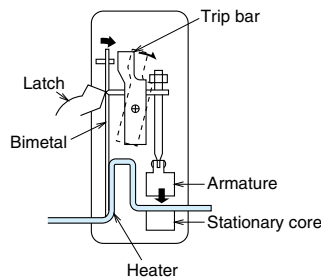

Fig. 4.4

1. Time-Delay Operation  
An overcurrent heats and warps the bimetal to actuate the trip bar.
2. Instantaneous Operation  
If the overcurrent is excessive, magnetization of the stationary core is strong enough to attract the armature and actuate the trip bar.

### Hydraulic-Magnetic Type (NF50-FHU etc.)

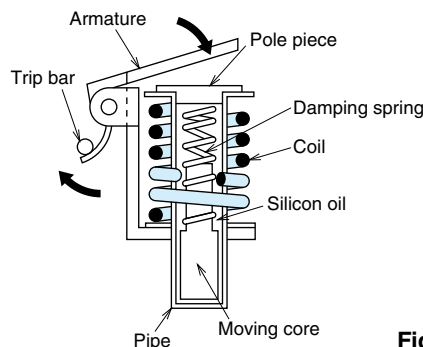

Fig. 4.5

1. Time-Delay Operation  
At an overcurrent flow, the magnetic force of the coil overcomes the spring, the core closes to the pole piece, attracts the armature, and actuates the trip bar.  
The delay is obtained by the viscosity of silicon oil.
2. Instantaneous Operation  
If the overcurrent is excessive, the armature is instantly attracted, without the influence of the moving core.

### Principle of Electronic Trip Relay (ETR) Operation

( NF125-SEV/HEV, NF250-SEV/HEV, etc. ) ( NF400-SEW~NF800-CEW )  
( NF1000-SEW~NF1600-SEW, etc. )

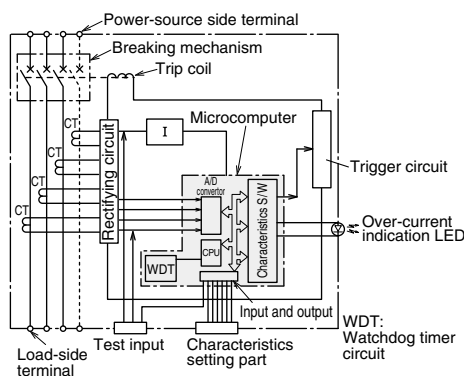

Fig. 4.6.1

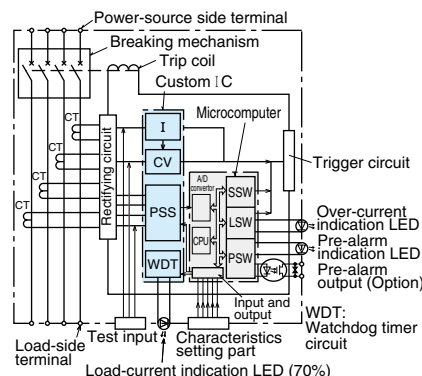

Fig. 4.6.2

1. The current flowing in each phase is monitored by a current transformer (CT).
2. Each phase of the transformed current undergoes full-phase rectification in the rectifier circuit.
3. After rectification, each of the currents are converted by a peak-conversion and an effective-value conversion circuit.
4. The largest phase is selected from the converted currents.
5. Each time-delay circuit generates a time delay corresponding to the largest phase.
6. The trigger circuit outputs a trigger signal.
7. The trip coil is excited, operating the switching mechanism.

### Number of tripping devices

Descriptions (e.g. 2P1E and 2P0E) are not given in the number of poles fields of some models. For these models, the same number of overcurrent tripping devices as the number of poles is provided in the circuit breakers.

2 poles: 2P2E, 3 poles: 3P3E, 4 poles: 4P4E or 4P3E

(Some 4-pole models do not have overcurrent tripping devices for the neutral poles.)

## 2. Construction of ELCB

### ● Arc-Extinguishing Device

ELCBs feature excellent arc-extinguishing performance by virtue of the optimum combination of grid gap, shape, and material.

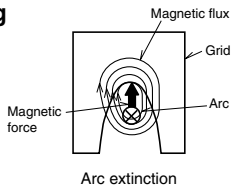

### ● Trip Button (Push to Trip)

Enables tripping mechanically from outside, for confirming the operation of the accessory switches and the manual resetting function.

### ● Overcurrent Tripping Device

The use of the proven mechanism of ELCBs ensures reliable detection of overcurrent.

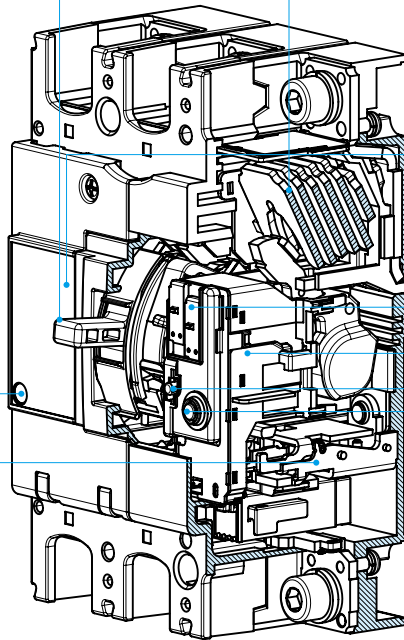

Fig. 4.7 Construction

### ● Switching Mechanism

The contacts open and close rapidly, regardless of the moving speed of the handle, minimizing contact wear and ensuring safety.

### ● Window Frame

Since the handle, trip button, test button, leakage display button and nameplate are located in one area, it is easy to cut the panel.

### ● Sensitivity Switching Device

The rated sensitivity current can be easily changed. A 3-stage switching device for 100, 200 and 500mA and a 2-stage switching device for 200 and 500mA are available.

### ● Leakage Display

Target type with display button. The display is automatically reset by the handle.

### ● Test Button

The button has excellent durability and performance to withstand inspection at start.

### ● Leakage Tripping Device

- The semiconductor circuit unit, which is the most important part of the device, is an electronic type using highly reliable ICs.
- For improvement of the function for removing harmonic and surge components, two filters are provided to prevent unnecessary operations.
- The ZCT detects any minute current. It is covered with a magnetic shield and never operates unnecessarily owing to motor starting current.

Rated operational voltage	Applicable circuit voltage	Available voltage range
100-240V	100/110/200/220/230/240V	80 to 264V
100-440V	100/110/200/220/240/254/265/380/400/415/440V	80 to 484V
200-440V	200/220/240/254/265/380/400/415/440V	160 to 484V
100-200-415V	100/110/200/220/240/254/265/380/400/415/440V	80 to 484V
200-415V	200/220/240/254/265/380/400/415/440V	160 to 484V

### ● Operation

1. When an earth fault occurs, voltage is induced on the secondary side of the ZCT.
2. Factors of unnecessary operations, i.e. surge and noise components, are removed from the induced voltage.
3. The signal level is discriminated, and, when the level exceeds the specified level, the electromagnetic device is excited to trip the circuit breaker body.

### Overload and short-circuit

The use of the proven mechanism of ELCBs ensures reliable detection of overcurrent and earth fault to break the circuit.

### Revision to EN and GB/T Standards

Products for European markets must conform to the CE Marking Directives. To affix the CE mark to a product, it is necessary that the product conforms to European Standard (EN Standard). Products for China must conform to Chinese GB/T Standard to affix the CCC mark.

The third edition (2003) of EN Standard for circuit breakers, EN 60947-2, and GB/T Standard GB/T 14048.2 (2008) prescribe that the functions of earth leakage circuit breakers should normally work even in open phase condition. Products based on the previous EN Standard (second edition) have not been approved since June, 2006. Products based on the previous GB/T Standard (2001) have not been approved since January, 2011.

☆WS-V Series Earth Leakage Circuit Breakers (conforming to CE and CCC Standards) and UL 489 Listed Molded Case Circuit Breakers with earth leakage protection conform to the third edition of EN 60947-2 and GB/T 14048.2 2008 as 3-phase power supply earth leakage circuit breakers.

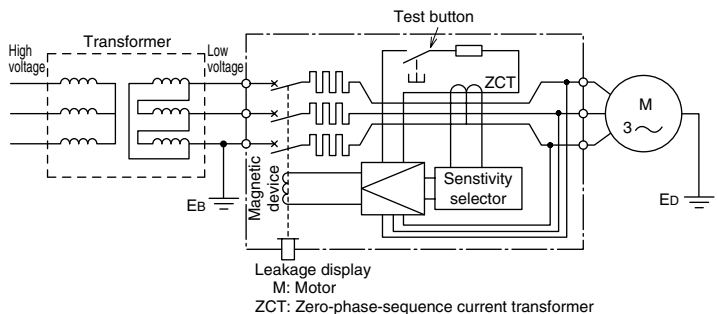

Fig. 4.8 Circuit configuration of ELCB (NV63-SV)

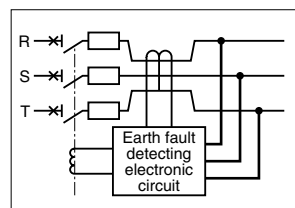

Fig. 4.9 Circuit diagram in 3-phase power supply ELCB

## 1. Selecting Procedure

### ■ MCCB (NF)

<b>Circuit used</b> <b>Applicable standard</b>	Phase and wire type, voltage, DC or AC, frequency, standard	<ul style="list-style-type: none"> <li>●Applicable phase and wire type 2 poles: 1-phase 2-wire 3 poles: 1-phase 2-wire, 1-phase 3-wire, 3-phase 3-wire 4 poles: 3-phase 4-wire</li> <li>●Specification list (pages 18 to 59)</li> <li>●List of received certifications (page 89)</li> </ul>
<b>Determination of rated current</b>	Kind and size of electric wire Kind and working conditions of load Selection conditions in internal standard and electrical equipment technical standards	<ul style="list-style-type: none"> <li>●Relationship between temperature and electric wire (page 72)</li> <li>●Selection of circuit breaker for motor branch circuit (page 77)</li> <li>●Selection of circuit breaker for electric lamp or electric heater circuit (page 75)</li> <li>●Selection of motor protection breaker (page 79)</li> <li>●Selection of circuit breaker for inverter circuit (page 80)</li> <li>●Selection of circuit breaker on transformer primary side (page 81)</li> </ul>
<b>Determination of interrupting capacity</b>	Transformer capacity Electric wire thickness and length	<ul style="list-style-type: none"> <li>●Application based on breaking capacity (page 74)</li> <li>●Table of combinations for cascade breaking (page 87)</li> </ul>
<b>Examination of coordination</b>	Selective breaking	<ul style="list-style-type: none"> <li>●Operating characteristic curve (pages 146 to 246)</li> <li>●Table of combinations for selective breaking (page 85)</li> </ul>
<b>Determination of model</b>	Use	●Circuit Breakers for special purpose (page 61 to 64)
<b>Installation method</b>	Connection and molded case circuit breaker	<ul style="list-style-type: none"> <li>●Installation and connection (pages 98 to 106)</li> <li>●Boxed Circuit Breakers (page 137)</li> </ul>
<b>Accessories</b>	Internal accessories and external accessories Electric operation	<ul style="list-style-type: none"> <li>●Internal accessories (pages 108 to 122)</li> <li>●External accessories (pages 123 to 143)</li> <li>●Electrical Operated Circuit Breakers (pages 140 to 142)</li> </ul>

### ■ ELCB (NV)

<b>Circuit used</b> <b>Applicable standard</b>	Phase and wire type, voltage, DC or AC, frequency, standard	<ul style="list-style-type: none"> <li>●Specification list (pages 18 to 59)</li> <li>●List of received certifications (page 89)</li> </ul>
<b>Determination of rated current</b>	Kind and size of electric wire Kind and working conditions of load Selection conditions in internal standard and electrical equipment technical standards	<ul style="list-style-type: none"> <li>●Relationship between temperature and electric wire (page 72)</li> <li>●Selection of circuit breaker for motor branch circuit (page 77)</li> <li>●Selection of circuit breaker for electric lamp or electric heater circuit (page 75)</li> <li>●Selection of circuit breaker for inverter circuit (page 80)</li> <li>●Selection of circuit breaker on transformer primary side (page 81)</li> </ul>
<b>Determination of interrupting capacity</b>	Transformer capacity Electric wire thickness and length	<ul style="list-style-type: none"> <li>●Application based on breaking capacity (page 74)</li> <li>●Table of combinations for cascade breaking (page 87)</li> </ul>
<b>Determination of rated current sensitivity</b>	Purpose of protection Obligation of installation	<ul style="list-style-type: none"> <li>●Purpose of protection (page 92)</li> <li>●Selection of rated sensitivity current of circuit breaker for inverter circuit (page 80)</li> <li>●Method of switching between rated voltage and rated sensitivity current (page 262)</li> </ul>
<b>Examination of coordination</b>	Selective breaking Ground fault protection coordination	<ul style="list-style-type: none"> <li>●Operating characteristic curve (pages 146 to 246)</li> <li>●Table of combinations for selective breaking (page 85)</li> <li>●Combinations of ground fault protection coordination and devices (page 95)</li> </ul>
<b>Determination of model</b>	Use	●Circuit Breakers for special purpose (page 61 to 64)
<b>Installation method</b>	Connection and molded case circuit breaker	<ul style="list-style-type: none"> <li>●Installation and connection (pages 98 to 106)</li> <li>●Boxed Circuit Breakers (page 137)</li> </ul>
<b>Accessories</b>	Internal accessories and external accessories Electric operation	<ul style="list-style-type: none"> <li>●Internal accessories (pages 108 to 122)</li> <li>●External accessories (pages 123 to 143)</li> <li>●Electrical Operated Circuit Breakers (pages 140 to 142)</li> </ul>

## 2. Features and Performance

### ■ Features of MCCB

#### ● Molded Case Circuit Breakers (NF)

##### ① Time-delay trip function

This function conforms to the allowable current and time characteristics of electric wire and prevents operation caused by the starting current of a load device. When the overcurrent is large, the operating time is short, and when the overcurrent is small, the operating time is long.

##### ● In the case of electronic type

The electronic time-delay trip function includes a long time limit trip function conforming to the allowable current and time characteristics of conductor and a short time limit trip function for selective breaking for branch MCCB. The short time limit function operates after a delay of some cycles (0.06 to 0.3s) at overcurrent exceeding the short time limit tripping current. These functions can be adjusted by the knob.

##### ② Instantaneous trip function

This function breaks the circuit immediately when short-circuit current flows. A circuit breaker on which the instantaneous tripping current is adjustable has the advantage that coordination in operation with other protective devices, such as electromagnetic switches and low-voltage air circuit breakers, can be easily obtained. The instantaneous operating time (total interrupting time) can be divided as shown in Fig. 4-10.

##### ③ Operating characteristic curve

The operating characteristic curve indicates the relationship between magnitude of overcurrent and operating time. The maximum-minimum operating characteristic curve indicates that the operating time is in the range. Figs. 4-11 and 4-12 show examples of operating characteristic curves.

**Table 4-1 Overcurrent trip operating time (IEC 60947-2)**

Rated current of circuit breaker (A)	Operating time for 130% current
63 or less	Within 1h.
Over 63	Within 2h.

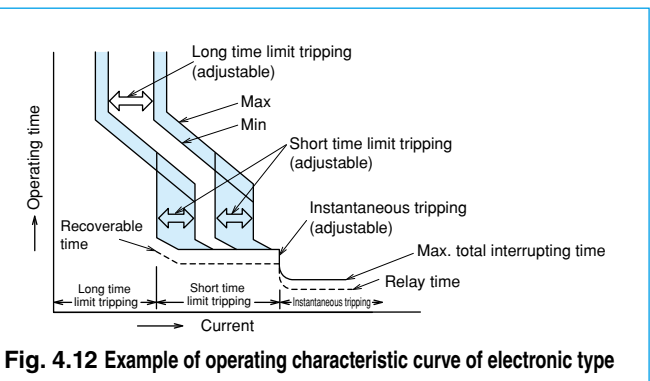
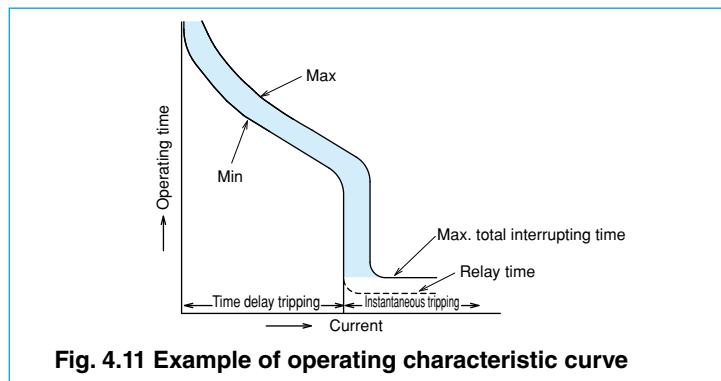
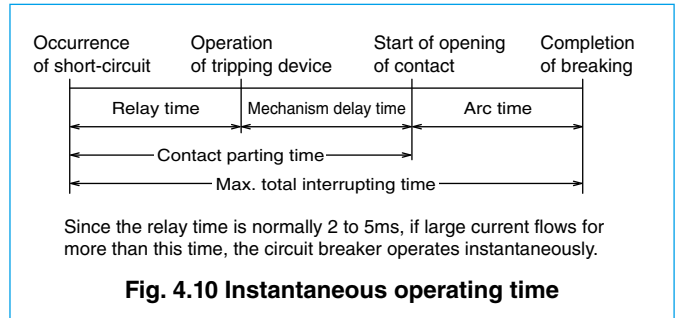

#### ● Motor Protection Breakers

- The motor protection breakers are circuit breakers to be used to protect general induction motors. They prevent motors being burnt not only by short-circuit current of circuits, but also by overcurrent caused by overload operation and locking of motors.
- The Motor Protection Breakers are finely classified according to rated current so that the breakers can be applied to various types of motors.
- Although their time-delay trip and instantaneous trip functions are almost the same as those of MCCB, they are designed to operate within 2 seconds to 30 seconds at 600% of the rated current in consideration of protection from motor starting current and locked current.

- There are many kinds of motors, and the motors have various allowable characteristics for overcurrent. Therefore, when applying a motor breaker, it is necessary to compare the allowable characteristics and the operating characteristics of the motor breaker. Note that, particularly, submersible motors may not be protected by ordinary motor breakers because their allowable locked time is short.
- When the motor starting current is large and the starting time is long and when the frequency of intermittent operation is high, motor breakers are unsuitable. In such a case, the use of a combination of an electromagnetic switch and MCCB (combination starter) is recommended.

### ● Characteristics of MCCB for DC circuits

When a 2-pole MCCB (250VDC or less) is used on a DC circuit, connect the poles in series.

When a 3- or 4-pole MCCB is used, refer to page 63 (for special DC voltage) or pages 18 to 25 (for DC). For DC high voltage, refer to pages 47 to 48.

If the breaker is not connected as specified, its tripping characteristics and breaking performance will change, and it cannot be used.

### ● Current-limiting characteristic

The current limiting refers to reduction of estimated short-circuit current depending on the circuit to prevent flow of the larger short-circuit current. The use of a class S, H or R which has excellent current-limiting characteristic or class U enables to reduce the passing energy at short-circuiting and protect the devices in the electric circuit from electromagnetic force and thermal stress.

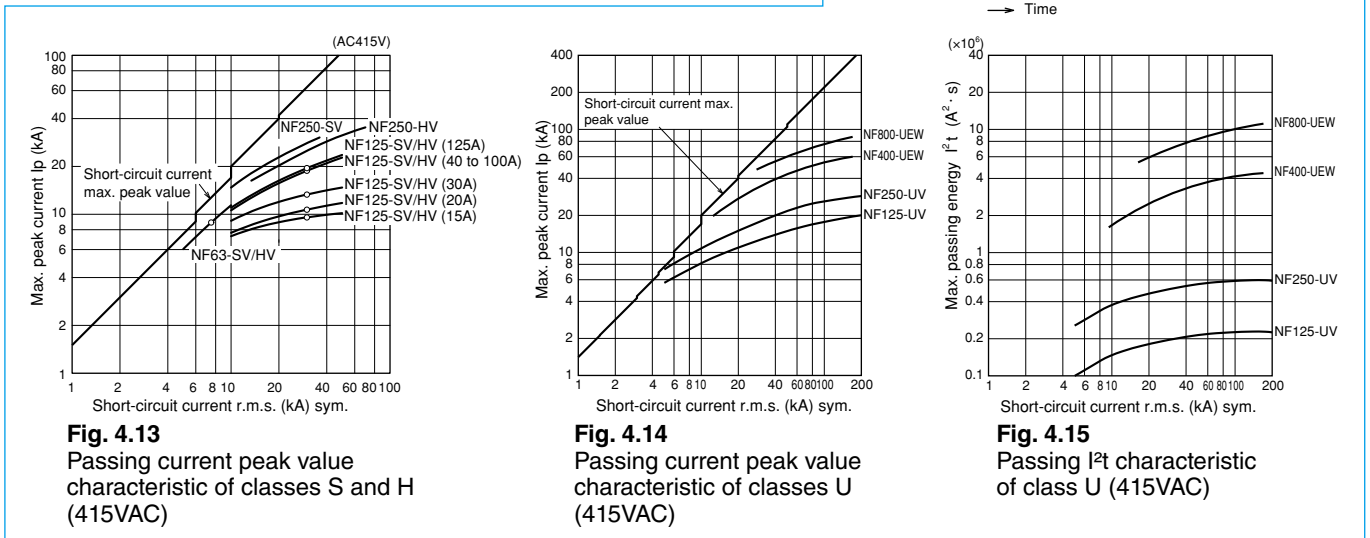
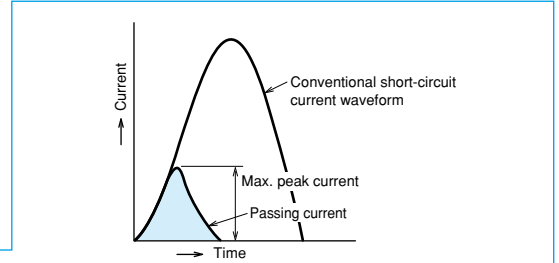

**Fig. 4.13**  
Passing current peak value characteristic of classes S and H (415VAC)

**Fig. 4.14**  
Passing current peak value characteristic of classes U (415VAC)

**Fig. 4.15**  
Passing  $I^2t$  characteristic of class U (415VAC)

### ■ Performance

#### ● Short-circuit breaking performance

Short-circuit current corresponding to the rated interrupting capacity is interrupted.

##### ● Outline of short-circuit test (IEC 60947-2)

- ① Rated limit short-circuit interrupting capacity ( $I_{cu}$ )  
Operating duty: O – 3min – CO
- ② Rated service short-circuit interrupting capacity ( $I_{cs}$ )  
Operating duty: O – 3min – CO – 3min – CO  
Upper limit of temperature rise of terminal after breaking: 80K or less  
O duty: The circuit breaker in the ON status carries and interrupts short-circuit current.  
CO duty: A shorted circuit is formed, and the circuit breaker is turned on to carry and interrupt short-circuit current.

#### ● Opening/closing performance

Table 4-2 shows the durability against opening and closing. See the durability against opening and closing as reference when using a circuit breaker as a switchgear.

The durability against tripping by SHT (shunt tripping device), UVT (undervoltage tripping device) and trip button is 10% of the total durability against opening and closing.

Note: Opening and closing operations are regarded as one time.

If a circuit breaker is regularly used to trip, the life of the circuit breaker will be significantly reduced.

**Table 4-2 Durability of MCCB against opening and closing (IEC 60947-2)**

Rated current (A)	Frequency of opening and closing (times/hour)	Durability against opening and closing (times)		
		With current flow	Without current flow	Total
100 or less	120	1500	8500	10000
101 to 315	120	1000	7000	8000
316 to 630	60	1000	4000	5000
631 to 2500	20	500	2500	3000
2501 or more	10	500	1500	2000

## 3. Current-carrying Capacity and Operating Temperature

### ■ Operating current vs. ambient temperature

Rated current of circuit breakers is adjusted for the rated ambient temperature. This is because circuit breakers are often installed in a casing as a switchboard or a control board, and temperature of the installed place of the breaker becomes higher than ambient temperature of the wires. If temperature of the installation site of circuit breakers greatly differ from the rated ambient temperature, it is necessary to correct rated current according to the temperature correction curve (shown in the Paragraph of characteristics and outside shape in the catalog). Load current can be increased up to the rated current corrected according to ambient temperature.

However, set current rating with enough allowance while taking fluctuation of power voltage and load current into consideration so that maximum operating current may not exceed the rated current.

### (1) Cautionary instructions for using heat resistive wire

For using insulated wires of higher heat resistance than that of 600V PVC insulated wire (allowable temperature 60°C), it is necessary to take the following points into consideration.

For circuit breakers, size of test wire is stipulated by each test current in IEC60947-1.

The values are calculated figures when bus bars (that are defined by IEC60947-1) are connected and tested in open-air usage environment. If size of connection wire is thinner than the test wire size, temperature of the breaker terminals increases and overcurrent tripping operation characteristic may change in some cases. (Operating time becomes shorter usually.) So please select the size of the connected wire so that the maximum usage current does not exceed the value in Fig. 4-16 with correction rate. At motor load, for example, influence of change in operation characteristic by difference in size of connection wire is insignificant and can be disregarded because the load current is far lower than the rated current of the circuit breaker.

Since the temperature test conditions for circuit breakers with IEC60947-1 are different from the state that the circuit breakers are mounted inside panels, please make sure that the circuit breakers are tested with the actual usage assembly inside panels.

**Table 4-3 IEC 60947-1 Size of test wire**

Range of test current (A)		Conductor size (mm <sup>2</sup> )
0 <	≤ 15	2.5
15	20	2.5
20	25	4.0
25	32	6.0
32	50	10
50	65	16
65	85	25
85	100	35
100	115	35
115	130	50
130	150	50
150	175	70
175	200	95
200	225	95
225	250	120
250	275	150
275	300	185
300	350	185
350	400	240
400	500	150(2)
500	630	185(2)

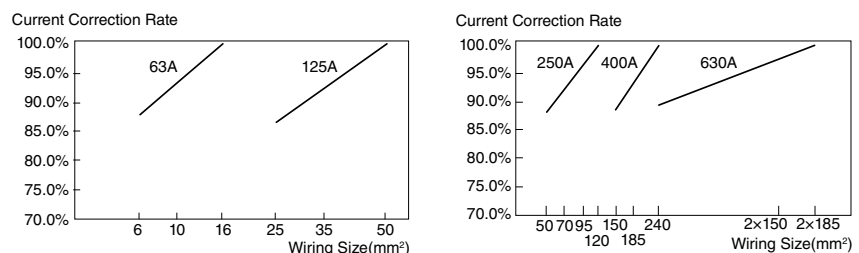

**Fig. 4.16 Current Correction Example at IEC60947-1**

## (2) Connection of aluminum conductors

- When aluminum conductors are connected, be careful to prevent the contact resistance (due to the oxidized film of aluminum) from being increased.
- The surface of the connection point of the aluminum conductors shall be properly treated by plating (zinc displacement-Copper-Silver) or by joint compound. If the treatment is done only by joint compound, reliability is low, this should be limited to when plating is impossible (eg. at site).
- For aluminum cables, use compression terminals that are exclusively for aluminum cables.
- The compression portion of the terminal shall be provided with taping, and the aluminum wire shall not be exposed to the atmosphere.

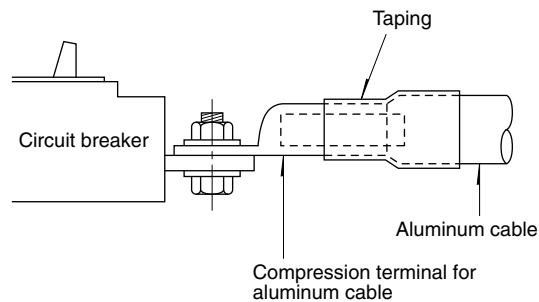

Fig. 4.17 Example of connection of aluminum conductor

## (3) Maximum operating current of installation without clearance between breakers

In case of installation without clearance between breakers, because malfunction failures can result by heat of breaker, use the operating current not to exceed the below value.

Table 4-4

Model								Maximum operating current	
BH-D6	BH-D10	BH-DN	BV-DN					80% of rated current	
CP30-BA	CP30-HU								
NF32-SV	NF63-CV			NV32-SV	NV63-CV				
NF63-SV	NF63-HV			NV63-SV	NV63-HV				
NF125-CV	NF125-SGV	NF125-SEV		NV125-CV					
NF125-SV	NF125-LGV	NF125-HEV		NV125-SV					
NF125-HV	NF125-HGV			NV125-HV					
NF125-RGV									
NF160-SGV	NF160-LGV	NF160-HGV							
NF250-CV	NF250-LGV			NV250-CV					
NF250-SV	NF250-SGV			NV250-SV	NV250-SEV				
NF250-HV	NF250-HGV	NF250-RGV		NV250-HV	NV250-HEV				
NF400-CW	NF400-SW	NF400-SEW	NF400-HEW	NV400-CW	NV400-SW	NV400-SEW	NV400-HEW		90% of rated current
NF400-REW	NF400-UEW								
NF630-CW	NF630-SW	NF630-SEW	NF630-HEW	NV630-CW	NV630-SW	NV630-SEW	NV630-HEW		
NF630-REW									
NF800-CEW	NF800-SDW	NF800-SEW	NF800-HEW	NV800-SEW	NV800-HEW				
NF800-REW	NF800-UEW								

# 4 Selection 2 Selection of MCCB and ELCB

## 4. Application of Circuit Breaker According to Breaking Capacity

### MCCB (NF)

Class C, FAU Series    Classes S, H and R

(The correlation between transformers and interrupting capacities is intended for short-circuiting just under the secondary voltage of 3-phase standard transformer, 210V or 420V, or the voltage of single-phase 3-wire transformer, 210V.)

Table 4-5 230VAC

3ph trans. capacity (kVA)	30 or less	50 to 75	100	150 to 300	500 to 1500	2000 to 3000										
1ph trans. capacity (kVA)	20 or less	30 to 50	75	100 to 150	200 to 300	-										
Breaking capacity (kA) (sym)	2.5	5	7.5	10	15	25	30	35	36	50	85	100	125	150	170	200
Frame (A)	30 • 32	NF30-FAU (*1)	NF32-SV													
	50 • 60 • 63	NF50-FAU (*1)	NF63-CV	NF63-SV	NF63-HV											
	100 • 125	NF125-CV				NF125-SV	NF125-HV		NF125-SEV	NF125-HEV	NF125-RGV	NF125-UV				
	225 • 250	NF250-CV				NF250-SV	NF250-SEV		NF250-HV	NF250-HEV	NF250-RGV	NF250-UV				
	400	NF400-CW				NF400-SW/SEW	NF400-HEW		NF400-REW	NF400-UEW						
	600 • 630	NF630-CW				NF630-SW/SEW	NF630-HEW		NF630-REW	NF630-UEW						
	800	NF800-CEW				NF800-SW/SEW	NF800-HEW		NF800-REW	NF800-UEW						
	1000 to 4000	NF1000-SEW~NF1600-SEW														

\*1 The breaking capacity of NF30-FAU and NF50-FAU having a rated current of 5A is 1.5kA.

Table 4-6 440VAC

Trans. capacity (kVA)	30 or less	50 to 100	150 to 300	500 to 1000	1500 to 2000	2500 to 5000										
Breaking capacity (kA) (sym)	1.5	2.5	7.5	10	15	20	25	30	35	36	50	65	85	125	200	
Frame (A)	30 • 32	NF32-SV														
	50 • 60 • 63	NF63-CV	NF63-SV	NF63-HV												
	100 • 125	NF125-CV		NF125-SV	NF125-HV											
	225 • 250	NF250-CV		NF250-SV	NF250-SEV		NF250-HV	NF250-HEV		NF250-RV	NF250-UV					
	400	NF400-CW		NF400-SW/SEW	NF400-HEW		NF400-REW	NF400-UEW								
	600 • 630	NF630-CW		NF630-SW/SEW	NF630-HEW		NF630-REW	NF630-UEW								
	800	NF800-CEW		NF800-SW/SEW	NF800-HEW		NF800-REW	NF800-UEW								
	1000 to 4000	NF1000-SEW~NF1600-SEW														

### ELCB (NV)

Class C, FAU Series    Classes S, H and R

(The correlation between transformers and interrupting current is intended for short-circuiting just under the secondary voltage of 3-phase standard transformer, 210V or 420V, or the voltage of single-phase 3-wire transformer, 210V.)

Table 4-7 230VAC

3ph trans. capacity (kVA)	30 or less	50 to 75	100	150 to 300	500 to 1500	2000 to 3000								
1ph trans. capacity (kVA)	20 or less	30 to 50	75	100 to 150	200 to 300	-								
Breaking capacity (kA) (sym)	1.5	2.5	5	7.5	10	15	25	30	35	36	50	85	100	125
Frame (A)	30 • 32	NV30-FAU (*1)	NV32-SV											
	50 • 60 • 63	NV50-FAU (*1)	NV63-CV	NV63-SV	NV63-HV									
	100 • 125	NV125-CV				NV125-SV	NV125-HV							
	225 • 250	NV250-CV				NV250-SV	NV250-SEV		NV250-HV	NV250-HEV				
	400	NV400-CW				NV400-SW/SEW	NV400-HEW		NV400-REW	NV400-UEW				
	600 • 630	NV630-CW				NV630-SW/SEW	NV630-HEW		NV630-REW	NV630-UEW				
	800	NV800-SEW				NV800-SW/SEW	NV800-HEW		NV800-REW	NV800-UEW				

\*1 The interrupting current of NF30-FAU and NF50-FAU having a rated current of 5A is 1.5kA.

Table 4-8 440VAC

Trans. capacity (kVA)	30 or less	50 to 100	150 to 300	500 to 1000	1500 to 2000	2500 to 5000								
Breaking capacity (kA) (sym)	2.5	5	7.5	10	15	25	30	35	36	50	65	70	85	125
Frame (A)	30 • 32	NV32-SV												
	50 • 60 • 63	NV63-CV	NV63-SV	NV63-HV										
	100 • 125	NV125-CV		NV125-SV	NV125-HV									
	225 • 250	NV250-CV		NV250-SV	NV250-SEV		NV250-HV	NV250-HEV						
	400	NV400-CW		NV400-SW/SEW	NV400-HEW		NV400-REW	NV400-UEW						
	600 • 630	NV630-CW		NV630-SW/SEW	NV630-HEW		NV630-REW	NV630-UEW						
	800	NV800-SEW		NV800-SW/SEW	NV800-HEW		NV800-REW	NV800-UEW						

In some lighting apparatuses, the service life of circuit breakers may be reduced by the influence of inrush current applied when the lamps are turned on. Periodically check for abnormal temperature rise of the circuit breaker in such an apparatus.

## 5. Selection of Circuit Breaker for Electric Lamp or Heater Circuit

The maximum working current is 0.8 times the rated current of each circuit breaker.

### ■ MCCB (NF)

Please refer to the detailed specifications of the rated current that can be manufactured with each model name.

Table 4-9 230VAC

Max. working current (A)	Rated current of circuit breaker (A)	Breaking capacity (kA) 230VAC (Icu sym)															
		5	7.5	10	15	25	30	36	50	85	100	125	150	170	200		
12	15																
16	20		NF32-SV														
24	30																
32	40																
40	50		NF63-CV		NF63-SV	NF63-HV			NF125-SV								
48	60																
60	75																
80	100								NF125-SV	NF125-SEV		NF125-HV	NF125-HEV		NF125-RGV	NF125-UV	
100	125																
120	150																
140	175																
160	200																
180	225																
200	250																
240	300																
280	350																
320	400																
400	500																
480	600																
560	700																
640	800																
800	1000																
960	1200																
1120	1400																
1280	1600																

Please refer to the detailed specifications of the rated current that can be manufactured with each model name.

Table 4-10 440VAC

Max. working current (A)	Rated current of circuit breaker (A)	Breaking capacity (kA) 440VAC (Icu sym)															
		2.5	5	7.5	10	25	30	36	45	50	70	85	125	150	200		
12	15																
16	20																
24	30																
32	40																
40	50																
48	60																
60	75																
80	100																
100	125																
120	150																
140	175																
160	200																
180	225																
200	250																
240	300																
280	350																
320	400																
400	500																
480	600																
560	700																
640	800																
800	1000																
960	1200																
1120	1400																
1280	1600																

Please refer to the detailed specifications of the rated current that can be manufactured with each model name.

# 4 Selection 2 Selection of MCCB and ELCB

## ELCB (NV)

**Table 4-11 230VAC**

Please refer to the detailed specifications of the rated current that can be manufactured with each model name.

Max. working current (A)	Rated current (A)	Breaking capacity (kA) 230VAC (Icu sym)											
		2.5	5	7.5	10	15	25	30	36	50	85	100	125
12	15	NV32-SV		NV32-SV		NV63-HV		NV125-HV					
16	20	NV32-SV		NV32-SV		NV63-HV		NV125-HV					
24	30	NV32-SV		NV32-SV		NV63-HV		NV125-HV					
32	40	NV32-SV		NV32-SV		NV63-HV		NV125-HV					
40	50	NV63-CV		NV63-SV		NV63-HV		NV125-HV		NV125-HV		NV125-HV	
48	60	NV63-CV		NV63-SV		NV63-HV		NV125-HV		NV125-HV		NV125-HV	
60	75	NV63-CV		NV63-SV		NV63-HV		NV125-HV		NV125-HV		NV125-HV	
80	100	NV125-CV		NV125-SV		NV125-SV		NV125-HV		NV125-HV		NV125-HV	
100	125	NV125-CV		NV125-SV		NV125-SV		NV125-HV		NV125-HV		NV125-HV	
120	150	NV250-CV		NV250-SV		NV250-SV		NV250-HV		NV250-HV		NV250-HV	
140	175	NV250-CV		NV250-SV		NV250-SV		NV250-HV		NV250-HV		NV250-HV	
160	200	NV250-CV		NV250-SV		NV250-SV		NV250-HV		NV250-HV		NV250-HV	
180	225	NV250-CV		NV250-SV		NV250-SV		NV250-HV		NV250-HV		NV250-HV	
200	250	NV250-CV		NV250-SV		NV250-SV		NV250-HV		NV250-HV		NV250-HV	
240	300	NV400-CW		NV400-SW		NV400-SW		NV400-HV		NV400-HV		NV400-HV	
280	350	NV400-CW		NV400-SW		NV400-SW		NV400-HV		NV400-HV		NV400-HV	
320	400	NV400-CW		NV400-SW		NV400-SW		NV400-HV		NV400-HV		NV400-HV	
400	500	NV630-CW		NV630-SW		NV630-SW		NV630-HV		NV630-HV		NV630-HV	
480	600	NV630-CW		NV630-SW		NV630-SW		NV630-HV		NV630-HV		NV630-HV	
560	700	NV800-SEW		NV800-SEW		NV800-SEW		NV800-SEW		NV800-SEW		NV800-SEW	
640	800	NV800-SEW		NV800-SEW		NV800-SEW		NV800-SEW		NV800-SEW		NV800-SEW	

Please refer to the detailed specifications of the rated current that can be manufactured with each model name.

**Table 4-12 440VAC**

Max. working current (A)	Rated current (A)	Breaking capacity (kA) 440VAC (Icu sym)												
		2.5	5	7.5	10	25	30	36	45	50	70	85	125	
12	15	NV32-SV		NV63-SV		NV63-HV		NV125-SV		NV125-HV				
16	20	NV32-SV		NV63-SV		NV63-HV		NV125-SV		NV125-HV				
24	30	NV32-SV		NV63-SV		NV63-HV		NV125-SV		NV125-HV				
32	40	NV32-SV		NV63-SV		NV63-HV		NV125-SV		NV125-HV				
40	50	NV63-CV		NV63-SV		NV63-HV		NV125-SV		NV125-HV		NV125-HV		NV125-HV
48	60	NV63-CV		NV63-SV		NV63-HV		NV125-SV		NV125-HV		NV125-HV		NV125-HV
60	75	NV63-CV		NV63-SV		NV63-HV		NV125-SV		NV125-HV		NV125-HV		NV125-HV
80	100	NV125-CV		NV125-SV		NV125-SV		NV125-HV		NV125-HV		NV125-HV		NV125-HV
100	125	NV125-CV		NV125-SV		NV125-SV		NV125-HV		NV125-HV		NV125-HV		NV125-HV
120	150	NV125-CV		NV125-SV		NV125-SV		NV125-HV		NV125-HV		NV125-HV		NV125-HV
140	175	NV250-CV		NV250-SV		NV250-SV		NV250-HV		NV250-HV		NV250-HV		NV250-HV
160	200	NV250-CV		NV250-SV		NV250-SV		NV250-HV		NV250-HV		NV250-HV		NV250-HV
180	225	NV250-CV		NV250-SV		NV250-SV		NV250-HV		NV250-HV		NV250-HV		NV250-HV
200	250	NV250-CV		NV250-SV		NV250-SV		NV250-HV		NV250-HV		NV250-HV		NV250-HV
240	300	NV400-CW		NV400-SW		NV400-SW		NV400-HV		NV400-HV		NV400-HV		NV400-HV
280	350	NV400-CW		NV400-SW		NV400-SW		NV400-HV		NV400-HV		NV400-HV		NV400-HV
320	400	NV400-CW		NV400-SW		NV400-SW		NV400-HV		NV400-HV		NV400-HV		NV400-HV
400	500	NV630-CW		NV630-SW		NV630-SW		NV630-HV		NV630-HV		NV630-HV		NV630-HV
480	600	NV630-CW		NV630-SW		NV630-SW		NV630-HV		NV630-HV		NV630-HV		NV630-HV
560	700	NV800-SEW		NV800-SEW		NV800-SEW		NV800-SEW		NV800-SEW		NV800-SEW		NV800-SEW
640	800	NV800-SEW		NV800-SEW		NV800-SEW		NV800-SEW		NV800-SEW		NV800-SEW		NV800-SEW

4

2 Selection

# 6. Selection of Circuit Breaker for Motor Branch Circuit

(direct-to-line starting or Y-Δ starting)

## MCCB (NF)

Motor is protected from overload by electromagnetic switch. Circuit breaker is installed to protect circuit from short-circuit.

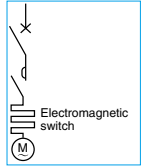

Table 4-13 200/220VAC for 3-phase induction motor

For 4-pole motor	Electromagnetic contactor	Breaking capacity (kA) 230VAC (Icu sym)																	
		7.5		15		25		30(*1)		50		85		100		150(*2)		200	
Output (kW)	Full-load current (A)	Model	Heater nominal (A)	Model	Rating	Model	Rating	Model	Rating	Model	Rating	Model	Rating	Model	Rating	Model	Rating	Model	Rating
0.1	0.7	N10-N21	0.7	NF32-SV (3)	(3)	NF63-SV (3)	(3)	NF63-HV (10)	(10)	NF125-SV (15)	(15)	NF125-SV (15)	(15)	NF125-HV (15)	(15)	NF125-SV (15)	(15)	NF125-SV (15)	(15)
0.2	1.2																		
0.4	2.1	N10-N21	2.1	NF32-SV	5	NF63-SV	5	NF63-HV (10)	(10)	NF125-SV (15)	(15)	NF125-SV (15)	(15)	NF125-HV (15)	(15)	NF125-SV (15)	(15)	NF125-SV (15)	(15)
0.75	3.7	N10-N21	3.6	NF32-SV	10	NF63-SV	10	NF63-HV (10)	(10)	NF125-SV (15)	(15)	NF125-SV (15)	(15)	NF125-HV (15)	(15)	NF125-SV (15)	(15)	NF125-SV (15)	(15)
1.5	6.4	N10-N25	6.6	NF32-SV	15	NF63-SV	15	NF63-HV (15)	(15)	NF125-SV (15)	(15)	NF125-SV (15)	(15)	NF125-HV (15)	(15)	NF125-SV (15)	(15)	NF125-SV (15)	(15)
2.2	9.1	N10-N35	9	NF32-SV	20	NF63-SV	20	NF63-HV (20)	(20)	NF125-SV (20)	(20)	NF125-SV (20)	(20)	NF125-HV (20)	(20)	NF125-SV (20)	(20)	NF125-SV (20)	(20)
3.7	15	N18-N35	15	NF32-SV	30	NF63-SV	30	NF63-HV (30)	(30)	NF125-SV (30)	(30)	NF125-SV (30)	(30)	NF125-HV (30)	(30)	NF125-SV (30)	(30)	NF125-SV (30)	(30)
5.5	22	N25-N35-N50-N65	22	NF63-CV	50	NF63-SV	50	NF63-HV (50)	(50)	NF125-SV (50)	(50)	NF125-SV (50)	(50)	NF125-HV (50)	(50)	NF125-SV (50)	(50)	NF125-SV (50)	(50)
7.5	29	N35-N50-N80	29	NF63-CV	60	NF63-SV	60	NF63-HV (60)	(60)	NF125-SV (60)	(60)	NF125-SV (60)	(60)	NF125-HV (60)	(60)	NF125-SV (60)	(60)	NF125-SV (60)	(60)
11	44	N50-N95	42					NF125-CV	75	NF125-SV	75	NF125-SV	75	NF125-HV	75	NF125-SV	75	NF125-SV	75
15	55	N65-N125	54					NF125-CV	100	NF125-SV	100	NF125-SV	100	NF125-HV	100	NF125-SV	100	NF125-SV	100
5.5	22	—	22	NF63-CV	50	NF63-SV	50	NF63-HV	50	NF125-SV	50	NF125-SV	50	NF125-HV	50	NF125-SV	50	NF125-SV	50
7.5	29	—	29	NF63-CV	60	NF63-SV	60	NF63-HV	60	NF125-SV	60	NF125-SV	60	NF125-HV	60	NF125-SV	60	NF125-SV	60
11	44	—	42					NF125-CV	75	NF125-SV	75	NF125-SV	75	NF125-HV	75	NF125-SV	75	NF125-SV	75
15	55	—	54					NF125-CV	100	NF125-SV	100	NF125-SV	100	NF125-HV	100	NF125-SV	100	NF125-SV	100
18.5	67	N80-N125	67					NF125-CV	100	NF125-SV	100	NF125-SV	100	NF125-HV	100	NF125-SV	100	NF125-SV	100
22	85	N95-N150	82					NF250-CV	150			NF250-SV	150	NF250-HV	150	NF250-SV	150	NF250-SV	150
30	110	N125-N220	105					NF250-CV	175			NF250-SV	175	NF250-HV	175	NF250-SV	175	NF250-SV	175
37	130	N150-N220	125					NF250-CV	225			NF250-SV	225	NF250-HV	225	NF250-SV	225	NF250-SV	225
45	164	N180-N400	150							NF400-CW	400	NF400-SW	300	NF400-HEW	250	NF400-REW	250	NF400-UEW	250
55	195	N220-N400	180							NF400-CW	500	NF400-SW	300	NF400-HEW	300	NF400-REW	300	NF400-UEW	300
75	267	N300-N400-(N600)	250							NF630-CW	600	NF630-SW	500	NF400-HEW	400	NF400-REW	400	NF400-UEW	400
90	320	N300-N400-(N600-N800)	330							NF800-CW	600	NF630-SW	600	NF630-HEW	500	NF630-REW	500	NF800-UEW	500
110	385	N300-N400-(N600-N800)	330							NF800-CW	600	NF630-SW	600	NF630-HEW	600	NF630-REW	600	NF800-UEW	600
132	470	(N600-N800)	500												NF1000-SEW	700			
160	580	(N600-N800)	500												NF1250-SEW	800			
200	720	(N800)	600												NF1600-SEW	1000			

Notes \*1 The breaking capacity of NF250-CV is 36kA. \*2 The breaking capacity of NF1000- to 1600-SEW is 125kA.

Table 4-14 400/440VAC for 3-phase induction motor

For 4-pole motor	Electromagnetic contactor	Breaking capacity (kA) 415VAC (Icu sym)																	
		2.5		7.5		10		25		30(*1)		50(*2)		70		150(*3)		200	
Output (kW)	Full-load current (A)	Model	Heater nominal (A)	Model	Rating	Model	Rating	Model	Rating	Model	Rating	Model	Rating	Model	Rating	Model	Rating	Model	Rating
0.2	0.6	N10-N21	0.7	NF32-SV (3)	(3)	NF63-SV (3)	(3)	NF63-HV (10)	(10)	NF125-SV (15)	(15)	NF125-HV (15)	(15)	NF125-SV (15)	(15)	NF125-SV (15)	(15)	NF125-SV (15)	(15)
0.4	1.1																		
0.75	1.9	N10-N21	1.7	NF32-SV	5	NF63-SV	5	NF63-HV (10)	(10)	NF125-SV (15)	(15)	NF125-HV (15)	(15)	NF125-SV (15)	(15)	NF125-SV (15)	(15)	NF125-SV (15)	(15)
1.5	3.2	N10-N21	3.6	NF32-SV	10	NF63-SV	10	NF63-HV (10)	(10)	NF125-SV (15)	(15)	NF125-HV (15)	(15)	NF125-SV (15)	(15)	NF125-SV (15)	(15)	NF125-SV (15)	(15)
2.2	4.6	N10-N21	5	NF32-SV	10	NF63-SV	10	NF63-HV (10)	(10)	NF125-SV (15)	(15)	NF125-HV (15)	(15)	NF125-SV (15)	(15)	NF125-SV (15)	(15)	NF125-SV (15)	(15)
3.7	7.5	N11-N35	6.6	NF32-SV	20	NF63-SV	20	NF63-HV (20)	(20)	NF125-SV (20)	(20)	NF125-HV (20)	(20)	NF125-SV (20)	(20)	NF125-SV (20)	(20)	NF125-SV (20)	(20)
5.5	11	N18-N35	11	NF32-SV	30	NF63-SV	30	NF63-HV (30)	(30)	NF125-SV (30)	(30)	NF125-HV (30)	(30)	NF125-SV (30)	(30)	NF125-SV (30)	(30)	NF125-SV (30)	(30)
7.5	15	N20-N35-N50	15	NF32-SV	30	NF63-SV	30	NF63-HV (30)	(30)	NF125-SV (30)	(30)	NF125-HV (30)	(30)	NF125-SV (30)	(30)	NF125-SV (30)	(30)	NF125-SV (30)	(30)
11	22	N25-N35-N50-N65	22	NF63-CV	50	NF63-SV	50	NF63-HV (50)	(50)	NF125-SV (50)	(50)	NF125-HV (50)	(50)	NF125-SV (50)	(50)	NF125-SV (50)	(50)	NF125-SV (50)	(50)
15	28	N35-N50-N80	28	NF63-CV	60	NF63-SV	60	NF63-HV (60)	(60)	NF125-SV (60)	(60)	NF125-HV (60)	(60)	NF125-SV (60)	(60)	NF125-SV (60)	(60)	NF125-SV (60)	(60)
18.5	34	N50-N95	35	NF63-CV	60	NF63-SV	60	NF125-CV	60	NF125-SV	60	NF125-HV	60	NF125-SV	60	NF125-SV	60	NF125-SV	60
22	42	N50-N95	42					NF125-CV	75	NF125-SV	75	NF125-HV	75	NF125-SV	75	NF125-SV	75	NF125-SV	75
30	55	N65-N125	54					NF125-CV	100	NF125-SV	100	NF125-HV	100	NF125-SV	100	NF125-SV	100	NF125-SV	100
37	65	N80-N150	67					NF125-CV	100	NF125-SV	100	NF125-HV	100	NF125-SV	100	NF125-SV	100	NF125-SV	100
45	82	N95-N150	82							NF250-CV	125	NF250-SV	125	NF250-HV	125	NF250-SV	125	NF250-SV	125
5.5	11	—	11	NF63-CV	30	NF63-SV	30	NF63-HV	30	NF125-SV	30	NF125-HV	30	NF125-SV	30	NF125-SV	30	NF125-SV	30
7.5	15	—	15	NF63-CV	40	NF63-SV	40	NF63-HV	40	NF125-SV	40	NF125-HV	40	NF125-SV	40	NF125-SV	40	NF125-SV	40
11	22	—	22	NF63-CV	50	NF63-SV	50	NF63-HV	50	NF125-SV	50	NF125-HV	50	NF125-SV	50	NF125-SV	50	NF125-SV	50
15	28	—	28	NF63-CV	60	NF63-SV	60	NF125-CV	60	NF125-SV	60	NF125-HV	60	NF125-SV	60	NF125-SV	60	NF125-SV	60
18.5	34	—	35	NF63-CV	60	NF63-SV	60	NF125-CV	60	NF125-SV	60	NF125-HV	60	NF125-SV	60	NF125-SV	60	NF125-SV	60
22	42	—	42					NF125-CV	75	NF125-SV	75	NF125-HV	75	NF125-SV	75	NF125-SV	75	NF125-SV	75
30	55	—	54					NF125-CV	100	NF125-SV	100	NF125-HV	100	NF125-SV	100	NF125-SV	100	NF125-SV	100
37	65	—	67					NF125-CV	100	NF125-SV	100	NF125-HV	100	NF125-SV	100	NF125-SV	100	NF125-SV	100
45	82	—	82							NF250-CV	150	NF250-SV	150	NF250-HV	150	NF250-SV	150	NF250-SV	150
55	96	N125-N220	105					NF250-CV	175	NF250-SV	175	NF250-HV	175	NF250-SV	175	NF250-SV	175	NF250-SV	175
75	134	N150-N220	125					NF250-CV	225	NF250-SV	225	NF250-HV	225	NF250-SV	225	NF250-SV	225	NF250-SV	225
90	160	N180-N400	150							NF250-SEW	225			NF250-HEW	225	NF400-REW	225	NF400-UEW	225
110	192	N180-N400	180											NF400-SW	350	NF400-HEW	300	NF400-REW	300
132	233	N220-N400	250											NF400-SW	400	NF400-HEW	400	NF400-REW	400
160	290	N300-N400-(N600)	250											NF630-SW	500	NF630-HEW	500	NF630-REW	500
200	360	N300-N400-(N600-N800)	330											NF630-SW	600	NF630-HEW	600	NF630-REW	600
220	389	N300-N400-(N600-N800)	—											NF630-SW	600	NF630-HEW	600	NF	

# 4 Selection 2 Selection of MCCB and ELCB

## ELCB (NV)

Table 4-15 200/220VAC for 3-phase induction motor

	For 4-pole motor		Electromagnetic contactor		Breaking capacity (kA) 230VAC (Icu sym)																
	Output (kW)	Full-load current (A)	Model	Heater nominal (A)	7.5		15(*1)		25		30(*2)		50		85		100				
Direct-to-line starting	0.1	0.7	N10-N21	0.7	NV63-CV	(5)	NV32-SV	(15)	NV63-HV	(15)			NV125-SV	(15)			NV125-HV	(15)			
	0.2	1.2		1.3																	
	0.4	2.1	N10-N21	2.1	NV63-CV	5	NV32-SV	(15)	NV63-HV	(15)			NV125-SV	(15)			NV125-HV	(15)			
	0.75	3.7	N10-N21	3.6	NV63-CV	10	NV32-SV	(15)	NV63-HV	(15)			NV125-SV	(15)			NV125-HV	(15)			
	1.5	6.4	N10-N25	6.6	NV63-CV	15	NV32-SV	15	NV63-HV	15			NV125-SV	15			NV125-HV	(15)			
	2.2	9.1	N10-N35	9	NV63-CV	20	NV32-SV	20	NV63-HV	20			NV125-SV	20			NV125-HV	20			
	3.7	15	N18-N35	15	NV63-CV	30	NV32-SV	30	NV63-HV	30			NV125-SV	30			NV125-HV	30			
	5.5	22	N25 • N35 • N50 • N65	22	NV63-CV	50	NV63-SV	50	NV63-HV	50			NV125-SV	50			NV125-HV	50			
	7.5	29	N35 • N50-N80	29	NV63-CV	60	NV63-SV	60	NV63-HV	60			NV125-SV	60			NV125-HV	60			
	11	44	N50-N95	42									NV125-CV	75	NV125-SV	75		NV125-HV	75		
	15	55	N65-N125	54									NV125-CV	100	NV125-SV	100		NV125-HV	100		
Y-Δ starting	5.5	22	-	22	NV63-CV	50	NV63-SV	50	NV63-HV	50			NV125-SV	50			NV125-HV	50			
	7.5	29	-	29	NV63-CV	60	NV63-SV	60	NV63-HV	60			NV125-SV	60			NV125-HV	60			
	11	44	-	42									NV125-CV	75	NV125-SV	75		NV125-HV	75		
	15	55	-	54									NV125-CV	100	NV125-SV	100		NV125-HV	100		
	18.5	67	N80-N125	67									NV125-CV	100	NV125-SV	100		NV125-HV	100		
	22	85	N95-N150	82									NV250-CV	150			NV250-SV	150	NV250-HV	150	
	30	110	N125-N220	105									NV250-CV	175			NV250-SV	175	NV250-HV	175	
	37	130	N150-N220	125									NV250-CV	225			NV250-SV	225	NV250-HV	225	
	45	164	N180-N400	150													NV400-SW	300	NV400-HEW	250	
	55	195	N220-N400	180													NV400-SW	300	NV400-HEW	300	
	75	267	N300 • N400 • (N600)	250													NV630-CW	500	NV400-SEW	400	NV400-HEW
90	320	N300 • N400 • (N600 • N800)	330													NV630-CW	600	NV400-SEW	400	NV400-HEW	400
110	385	N300 • N400 • (N600 • N800)	330													NV630-CW	600	NV630-SEW	500	NV630-HEW	500
																NV630-CW	600	NV630-SEW	600	NV630-HEW	600

Notes \*1 The breaking capacity of NV32-SV is 10kA. \*2 The breaking capacity of NV250-CV is 36kA.

Table 4-16 400/440VAC for 3-phase induction motor

	For 4-pole motor		Electromagnetic contactor		Breaking capacity (kA) 415VAC (Icu sym)																			
	Output (kW)	Full-load current (A)	Model	Heater nominal (A)	2.5		5		7.5		10		25		30(*1)		50(*2)		70					
Direct-to-line starting	0.2	0.6	N10-N21	0.7	NV63-CV	(5)	NV32-SV	(5)	NV63-SV	(5)	NV63-HV	(15)			NV125-SV	(15)	NV125-HV	(15)						
	0.4	1.1	N10-N21	1.3	NV63-CV	(5)	NV32-SV	(5)	NV63-SV	(5)	NV63-HV	(15)			NV125-SV	(15)	NV125-HV	(15)						
	0.75	1.9	N10-N21	1.7	NV63-CV	5	NV32-SV	5	NV63-SV	5	NV63-HV	(15)			NV125-SV	(15)	NV125-HV	(15)						
	1.5	3.2	N10-N21	3.6	NV63-CV	10	NV32-SV	10	NV63-SV	10	NV63-HV	(15)			NV125-SV	(15)	NV125-HV	(15)						
	2.2	4.6	N10-N21	5	NV63-CV	10	NV32-SV	10	NV63-SV	10	NV63-HV	(15)			NV125-SV	(15)	NV125-HV	(15)						
	3.7	7.5	N11-N35	6.6	NV63-CV	20	NV32-SV	20	NV63-SV	20	NV63-HV	20			NV125-SV	20	NV125-HV	20						
	5.5	11	N18-N35	11	NV63-CV	30	NV32-SV	30	NV63-SV	30	NV63-HV	30			NV125-SV	30	NV125-HV	30						
	7.5	15	N20-N35 • N50	15	NV63-CV	30	NV32-SV	30	NV63-SV	30	NV63-HV	30			NV125-SV	30	NV125-HV	30						
	11	22	N25 • N35 • N50 • N65	22	NV63-CV	50			NV63-SV	50	NV63-HV	50			NV125-SV	50	NV125-HV	50						
	15	28	N35 • N50-N80	28	NV63-CV	60			NV63-SV	60	NV63-HV	60			NV125-SV	60	NV125-HV	60						
	18.5	34	N50-N95	35											NV125-CV	60			NV125-SV	60	NV125-HV	60		
22	42	N50-N95	42											NV125-CV	75			NV125-SV	75	NV125-HV	75			
30	55	N65-N125	54											NV125-CV	100			NV125-SV	100	NV125-HV	100			
37	65	N80-N150	67											NV125-CV	100			NV125-SV	100	NV125-HV	100			
45	82	N95-N150	82															NV125-SV	100	NV125-HV	100			
Y-Δ starting	5.5	11	-	11	NV63-CV	30	NV32-SV	30	NV63-SV	30	NV63-HV	30			NV125-SV	30	NV125-HV	30						
	7.5	15	-	15	NV63-CV	40			NV63-SV	40	NV63-HV	40			NV125-SV	40	NV125-HV	40						
	11	22	-	22	NV63-CV	50			NV63-SV	50	NV63-HV	50			NV125-SV	50	NV125-HV	50						
	15	28	-	28	NV63-CV	60			NV63-SV	60	NV125-CV	60			NV125-SV	60	NV125-HV	60						
	18.5	34	-	35							NV125-CV	60			NV125-SV	60	NV125-HV	60						
	22	42	-	42							NV125-CV	75			NV125-SV	75	NV125-HV	75						
	30	55	-	54							NV125-CV	100			NV125-SV	100	NV125-HV	100						
	37	65	-	67							NV125-CV	100			NV125-SV	100	NV125-HV	100						
	45	82	-	82											NV250-CV	150			NV250-SV	150		NV250-HV	150	
	55	96	N125-N220	105											NV250-CV	175	NV250-SV	175			NV250-HV	175		
	75	134	N150-N220	125											NV250-CV	225	NV250-SV	225			NV250-HV	225		
90	160	N180-N400	150															NV250-SW	225			NV250-HV	225	
110	192	N180-N400	180															NV250-SEW	225			NV250-HV	225	
132	233	N220-N400	250																		NV400-SW	350	NV400-HEW	300
160	290	N300 • N400 • (N600)	250																		NV400-SW	400	NV400-HEW	400
200	360	N300 • N400 • (N600 • N800)	330																		NV630-SEW	500	NV630-HEW	500
																					NV630-SEW	600	NV630-HEW	600

Notes \*1 The breaking capacity of NV250-SV and NV250-SEW is 36kA. \*2 The breaking capacity of NV400-SW is 45kA.

Remark: 1. For the selecting conditions, please refer to the remarks on page 73.

### Example of Y-Δ starting current waveform (crest value envelope)

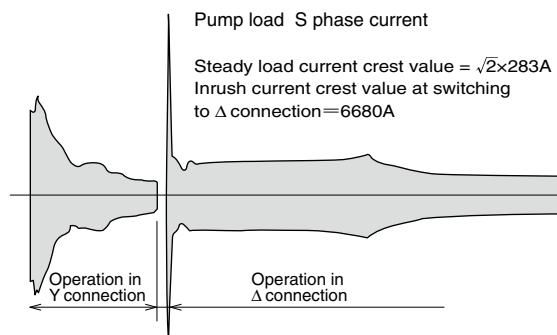

## 7. Selection of Motor Protection Breaker

### Motor Protection Breakers

In principle, the operating characteristic curve of a selected motor breaker must be lower than the heat characteristic of the motor. The following table shows the rated capacities of standard squirrel-cage 3-phase motors (4-pole) made by Mitsubishi Electric. The starting conditions are shown in the table.

Table 4-17 for 3-phase induction motor

Model	Motor Protection Breaker	NF32-SV	NF63-CV	NF63-SV	NF125-SV	NF250-SV	
Rated breaking capacity (kA)	200/230V	7.5	7.5	15	50	85	
	415/440V	2.5	2.5	7.5	30	36	
600% starting time limit (s)		2	32A or less: 2 40A or more: 7	32A or less: 2 40A or more: 7	32A or less: 2 40A or more: 7	5	
Startup inrush current limit (%)		1200	1200	1200	1200	1100	
Example of rated capacity of motor (kW)		Rated current	Rated current	Rated current	Rated current	Rated current	Model for combination with electromagnetic contactor
200/220V	400/440V						
	0.4						
0.2							
	0.75						
0.4							
0.75	1.5	4	4	4			
	2.2	5	5	5			
1.5		7.1	7.1	7.1			
	3.7	8	8	8			
2.2		10	10	10			
	5.5	12	12	12	(12.5)		
3.7		16	16	16	(16)		
	7.5	25	25	25	(25)		
5.5		32	32	32	32		
	18.5		40	40	(40)		
11			45	45	45		
	22				63		
15					71		
	37				90		
18.5					100		
	45						
	55						
	55						
30						125	
	75					150	
37						175	
	90					200	
45						225	
	110						

Remarks: 1. For the rated current in parentheses, breakers will be manufactured to order.  
 2. The approximate values of inrush current at direct-to-line starting are shown below. Up to 7.5kW: 1000% 11kW or more: 1200% 75kW or more: 1400%  
 When the starting current is large and the starting power factor is low, a combination with an electromagnetic switch selected in accordance with "Table of selection of circuit breaker for motor branch circuit" shown on page 77 is suitable.

#### Cautions

- Note that any circuit breaker operates when the startup inrush current, starting current and starting time exceed the conditions shown in the above table. Particularly, high-efficiency motors generally have higher starting current and lower starting torque compared to general-purpose motors, and motor breakers cannot be used for such motors.
- Note that a circuit breaker may operate when an electromagnetic contactor is opened or closed while a motor is running.
- Select a motor breaker having rated current approx. 1.0 to 1.1 times higher than the full load current of motor.

## 8. Selection of Circuit Breaker for Inverter Circuit

### ■ Selection of Circuit Breaker for Inverter Circuit

Since current containing harmonic components will flow, the rated current of circuit breaker must be approx. 1.4 times the inverter input current.

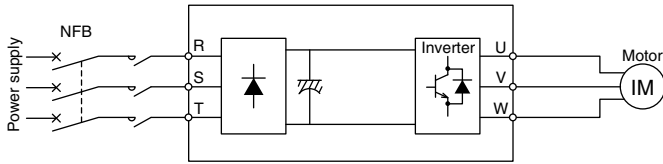

Install MCCB or ELCB on the primary side (power supply side) of the inverter. If it is installed on the secondary side, it may cause electronic circuit trouble or overheating.

Note The life cycle of the circuit breaker for the circuit on the inverter primary side will be reduced under the influence of transient inrush current. Install a switch.

**Table 4-18 3-phase 200V class**

Inverter input capacity kVA	Rated current of circuit breaker A	Inverter input capacity kVA	Rated current of circuit breaker A
5.5	30	41	175
9	40	52	225
12	50	66	300
17	75	80	350
20	100	100	500
28	125	110	500
34	150	132	600

### ■ Selection of rated sensitivity current of Earth Leakage Circuit Breaker for Inverter Circuit

Select the rated sensitivity current as stated below.

Circuit breakers for harmonics and surge: Rated sensitivity current  $I_{\Delta n} \geq 10 \times \{I_{g1} + I_{gn} + I_{g2} + I_{gm}\}$

General circuit breakers: Rated sensitivity current  $I_{\Delta n} \geq 10 \times \{I_{g1} + I_{gn} + 3 \times (I_{g2} + I_{gm})\}$

**Table 4-19-1**

Examples of leakage current from line when IV cable is wired in close contact with ground (wiring in metallic conduit) (3-phase 220V 60Hz)

Wire size mm <sup>2</sup>	Leakage current/km mA
6	135
10	140
16	169
25	176
35	203
50	205
70	241
95	247

Example 1

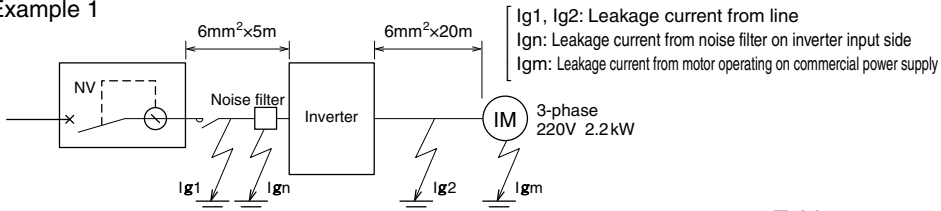

Example 2

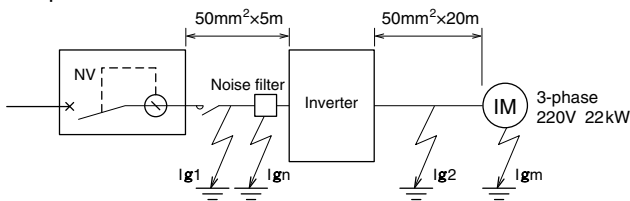

**Table 4-19-2**

Example of leakage current from 3-phase induction motor (220V 60Hz)

Motor output (kW)	Leakage current (mA)
2.2	0.2
3.7	0.29
5.5	0.32
7.5	0.42
11	0.55
15	0.63
18.5	0.72
22	0.8
30	0.96
37	1.1

### Example of selection 1

	Breaker for harmonics and surge	General breaker
Leakage current $I_{g1}$	$135 \times \frac{5}{1000} = 0.675$	$135 \times \frac{5}{1000} = 0.675$
Leakage current $I_{gn}$	0 (without noise filter)	
Leakage current $I_{g2}$	$135 \times \frac{20}{1000} = 2.7$	$135 \times \frac{20}{1000} \times 3 = 8.1$
Leakage current $I_{gm}$	0.18	$0.18 \times 3 = 0.54$
Total leakage current $I_g$	3.555	11.465
Rated sensitivity current ( $> I_g \times 10$ )	100	200

### Example of selection 2

	Breaker for harmonics and surge	General breaker
Leakage current $I_{g1}$	$205 \times \frac{5}{1000} = 1.025$	$205 \times \frac{5}{1000} = 1.025$
Leakage current $I_{gn}$	0 (without noise filter)	
Leakage current $I_{g2}$	$205 \times \frac{20}{1000} = 4.1$	$205 \times \frac{20}{1000} = 12.3$
Leakage current $I_{gm}$	0.72	$0.72 \times 3 = 2.16$
Total leakage current $I_g$	5.845	15.485
Rated sensitivity current ( $> I_g \times 10$ )	100	500

Remarks: 1. Circuit breakers for harmonics and surge can detect earth fault on the secondary side of inverter only when the operating frequency is 120Hz or less. In the case of star connection by neutral point grounding method, the sensitivity current for earth fault on the inverter secondary side is degraded. In this case, for protective ground for load device, apply Class C grounding (10Ω or less).

2. For general circuit breakers, the leakage current from the line between inverter and motor shall be calculated as three times the leakage current at the commercial frequency in consideration of harmonic content.

3. For the model names of circuit breakers for harmonics and surge, refer to the specification list in Section 2 of this document. Models not for harmonics and surge are general breakers.

## 9. Selection of Circuit Breaker for Transformer Primary Side

Notes 1. The life cycle of the circuit breaker for the circuit on the transformer primary side will be significantly reduced under the influence of excited inrush current. Install a switch to open and close the circuit.

2. Select a circuit breaker based on the example of excited inrush current of each transformer. When using a circuit breaker for a transformer, check the magnitude of excited inrush current with the transformer manufacturer.

### Single-phase 210V

Table 4-20-1 MCCB

Transformer capacity kVA	Rated primary current A	Example of transformer excited inrush current ①			Example of transformer excited inrush current ②			Example of transformer excited inrush current ③		
		Crest value of first wave (multiple)	Model	Rating A	Crest value of first wave (multiple)	Model	Rating A	Crest value of first wave (multiple)	Model	Rating A
5	23.8	45	NF125-CV(*1)	60	NF63-CV(*1)	50	24	NF63-CV(*1)	30	
			NF125-CV, NF125-SV, NF125-HV		NF125-CV(*1)			NF63-CV, NF63-SV		50
			NF125-SEV, NF125-HEV		NF125-CV, NF125-SV			NF125-CV(*2)		
7.5	35.7	45	NF250-CV, NF250-SV, NF250-HV	150	NF125-SEV	50	24	NF63-CV(*1)	50	
			NF250-SEV, NF250-HEV		NF125-CV(*1)			NF125-CV(*1)(*2)		60(50)
					NF250-CV, NF250-SV			NF125-CV, NF125-SV		
10	47.6	43	NF250-CV, NF250-SV, NF250-HV	200	NF125-CV(*1)	100	24	NF125-CV(*1)	60	
			NF250-SEV, NF250-HEV		NF250-CV, NF250-SV			NF125-CV, NF125-SV		100
					NF250-SEV					
15	71.4	43	NF400-CW	400	NF250-CV, NF250-SV	225	23	NF125-CV(*1)	100	
			NF400-SW		NF250-SEV			NF250-CV, NF250-SV		150
			NF400-SEW, NF400-HEW							
20	95.2	43	NF400-SW	400	NF400-SW	350	23	NF250-CV, NF250-SV	200	
			NF400-SEW, NF400-HEW		NF400-SEW			NF250-SEV		125
30	143	37	NF400-SW, NF400-HEW	200	NF400-SW	200	23	NF400-SW	300	
			NF630-SW		NF400-SEW			NF400-SEW		200
50	238	35	NF630-SEW(*1)	300	NF630-SEW	300	23	NF400-SEW(*1)	300	
			NF1000-SEW							
75	357	30	NF800-SEW(*1)	400	NF800-SEW(*1)	400	22	NF630-SEW	400	
			NF1250-SEW							
100	476	27	NF1000-SEW	800	NF1600-SEW	800	20	NF800-SEW(*1)	600	
150	714	24	-	-	-	-	19	NF1600-SEW	800	
200	952	21	-	-	-	-	19	-	-	
300	1429	17	-	-	-	-	16	-	-	
500	2381	-	-	-	-	-	-	-	-	

Table 4-20-2 ELCB

Transformer capacity kVA	Rated primary current A	Example of transformer excited inrush current ①			Example of transformer excited inrush current ②			Example of transformer excited inrush current ③		
		Crest value of first wave (multiple)	Model	Rating A	Crest value of first wave (multiple)	Model	Rating A	Crest value of first wave (multiple)	Model	Rating A
5	23.8	45	NV125-CV, NV125-SV, NV125-HV	100	NV125-CV, NV125-SV	75	24	NV63-CV, NV63-SV	50	
			NV125-SEV, NV125-HEV		NV125-SEV			NV125-CV		60
								NV125-SV		
7.5	35.7	45	NV250-CV, NV250-SV, NV250-HV	150	NV125-SEV	50	24	NV125-CV, NV125-SV	75	
			NV250-SEV, NV250-HEV		NV250-CV, NV250-SV			NV125-SEV		50
					NV250-SEV					
10	47.6	43	NV250-CV, NV250-SV, NV250-HV	200	NV250-CV, NV250-SV	150	24	NV125-CV, NV125-SV	100	
			NV250-SEV, NV250-HEV		NV250-SEV			NV250-CV, NV250-SV		125
15	71.4	43	NV400-CW	400	NV250-CV, NV250-SV	225	23	NV250-CV, NV250-SV	150	
			NV400-SW		NV250-SEV			NV250-SEV		125
			NV400-SEW, NV400-HEW							
20	95.2	43	NV400-SW	400	NV400-SW	350	23	NV250-CV, NV250-SV	200	
			NV400-SEW, NV400-HEW		NV400-SEW			NV250-SEV		125
30	143	37	NV400-SEW, NV400-HEW	200	NV400-SEW	200	23	NV400-SW	300	
			NV630-SEW					NV400-SEW		200
50	238	35	-	-	NV630-SEW	300	23	NV630-SEW	300	
75	357	30	-	-	-	-	22	NV630-SEW	400	
100	476	27	-	-	-	-	20	-	-	
150	714	24	-	-	-	-	19	-	-	
200	952	21	-	-	-	-	19	-	-	
300	1429	17	-	-	-	-	16	-	-	
500	2381	-	-	-	-	-	-	-	-	

Notes \*1 Examples of selection of high-instantaneous circuit breakers (special models) for primary side of transformer.

\*2 The circuit breakers with rating in parentheses are special models.

Remarks: 1. For the circuit breakers whose rated current is adjustable, the rated current values are shown.

2. The crest value of the first wave of excited inrush current shall be calculated based on the multiple for the crest value of the first wave in the table, and the calculated value shall not exceed the lower limit crest value of instantaneous tripping current of circuit breaker. The circuit breakers are selected on condition that the transformer rated current value does not exceed 0.9 times the circuit breaker rated current. If the multiple for the crest value of the first wave is different from that shown in the table, a circuit breaker must be separately selected.

# 4 Selection 2 Selection of MCCB and ELCB

## Single-phase 420V

Table 4-21-1 MCCB

Transformer capacity kVA	Rated primary current A	Example of transformer excited inrush current ①			Example of transformer excited inrush current ②			Example of transformer excited inrush current ③		
		Peak value of first wave (multiple)	Model	Rating A	Peak value of first wave (multiple)	Model	Rating A	Peak value of first wave (multiple)	Model	Rating A
5	11.9	45	NF63-CV(*1)	30	NF32-SV	15	24	NF32-SV, NF63-CV, NF63-SV	15	
			NF63-CV, NF63-SV, NF63-HV	50	NF63-CV, NF63-SV	15		NF125-SV	15	
			NF125-CV, NF125-SV, NF125-HV	50	NF125-SV	15		NF125-SV	15	
7.5	17.9	45	NF63-CV(*1)	50	NF63-CV(*1)	40	24	NF32-SV, NF63-CV, NF63-SV	30	
			NF125-CV, NF125-SV, NF125-HV	75	NF63-CV, NF63-SV	60		NF125-SV	30	
10	23.8	43	NF125-CV(*1)	60	NF63-CV(*1)	50	24	NF63-CV, NF63-SV	50	
			NF125-CV, NF125-SV, NF125-HV	100	NF125-CV, NF125-SV	75		NF125-CV(*2)	50	
15	35.7	43	NF125-CV(*1)	100	NF125-CV(*1)	60	23	NF63-CV(*1)	50	
			NF250-CV, NF250-SV, NF250-HV	150	NF125-CV, NF125-SV	100		NF125-CV(*1)(*2)	60(50)	
20	47.6	43	NF250-CV, NF250-SV, NF250-HV	200	NF125-CV(*1)	100	23	NF125-CV(*1)	60	
			NF250-SEV, NF250-HEV	125	NF250-CV, NF250-SV	150		NF125-CV, NF125-SV	100	
30	71.4	37	NF250-SEV, NF250-HEV	125	NF125-CV(*1)	225	23	NF125-CV(*1)	100	
			NF400-CW	350	NF250-CV, NF250-SV	125		NF250-CV, NF250-SV	150	
50	119	35	NF400-SW	400	NF400-SW	400	23	NF250-SEV	150	
			NF400-SEW, NF400-HEW	200	NF400-SEW	200		NF400-SEW	400	
75	179	30	NF400-SEW, NF400-HEW	200	NF400-SEW	200	22	NF400-SW	400	
			NF630-SW	500	NF400-SEW	200		NF400-SEW	200	
100	238	27	NF400-SEW(*1)	300	NF400-SEW(*1)	300	20	NF400-SEW	350	
			NF630-SW	600	NF630-SEW	300				
150	357	24	NF630-SEW(*1)	400	-	-	19	NF400-SEW(*1)	400	
								NF630-SEW	400	
200	476	21	NF800-SEW(*1)	600	NF800-SEW(*1)	600	19	NF800-SEW(*1)	600	
300	714	17	NF1250-SEW	800	NF1600-SEW	800	16	NF1250-SEW	800	
500	1190	-	-	-	-	-	-	-	-	

Table 4-21-2 ELCB

Transformer capacity kVA	Rated primary current A	Example of transformer excited inrush current ①			Example of transformer excited inrush current ②			Example of transformer excited inrush current ③		
		Peak value of first wave (multiple)	Model	Rating A	Peak value of first wave (multiple)	Model	Rating A	Peak value of first wave (multiple)	Model	Rating A
5	11.9	45	NV63-CV, NV63-SV, NV63-HV	50	NV32-SV	15	24	NV32-SV	15	
			NV125-CV	60	NV63-CV, NV63-SV	15		NV63-CV, NV63-SV	15	
			NV125-SV, NV125-HV	50	NV125-SV	15		NV125-SV	15	
7.5	17.9	45	NV125-CV, NV125-SV, NV125-HV	75	NV63-CV, NV63-SV	60	24	NV32-SV	30	
					NV125-CV, NV125-SV	60		NV63-CV, NV63-SV	30	
10	23.8	43	NV125-CV, NV125-SV, NV125-HV	100	NV125-CV, NV125-SV	75	24	NV63-CV, NV63-SV	50	
			NV125-SEV, NV125-HEV	50	NV125-SEV	50		NV125-CV	60	
15	35.7	43	NV250-CV, NV250-SV, NV250-HV	150	NV125-CV, NV125-SV	100	23	NV125-CV, NF125-SV	75	
			NV250-SEV, NV250-HEV	125	NV125-SEV	50		NV125-SEV	50	
20	47.6	43	NV250-CV, NV250-SV, NV250-HV	200	NV250-CV, NV250-SV	150	23	NV125-CV, NF125-SV	100	
			NV250-SEV, NV250-HEV	125	NV250-SEV	125		NV125-SEV	60	
30	71.4	37	NV250-SEV, NV250-HEV	125	NV250-CV, NV250-SV	225	23	NV250-SV, NV250-SV	150	
			NV400-CW	350	NV250-SEV	125		NV250-SEV	125	
50	119	35	NV400-SW	400	NV400-SW	400	23	NV250-SEV	150	
			NV400-SEW, NV400-HEW	200	NV400-SEW	200				
75	179	30	NV400-SEW, NV400-HEW	200	NV400-SEW	200	22	NV400-SW	400	
			NV630-SEW, NV630-HEW	300				NV400-SEW	200	
100	238	27	NV630-SEW, NV630-HEW	300	NV630-SEW	300	20	NV400-SEW	350	
			NV800-SEW, NV800-HEW	400	NV800-SEW	400				
150	357	24	-	-	24	-	19	NV630-SEW	400	
200	476	21	-	-	22	-	19	-	-	
300	714	17	-	-	18	-	16	-	-	
500	1190	-	-	-	-	-	-	-	-	

Notes \*1 Examples of selection of high-instantaneous circuit breakers (special models) for primary side of transformer.

\*2 The circuit breakers with rating in parentheses are special models.

Remarks: 1. For the circuit breakers whose rated current is adjustable, the rated current values are shown.

2. The peak value of the first wave of excited inrush current shall be calculated based on the multiple for the peak value of the first wave in the table, and the calculated value shall not exceed the lower limit peak value of instantaneous tripping current of circuit breaker. The circuit breakers are selected on condition that the transformer rated current value does not exceed 0.9 times the circuit breaker rated current. If the multiple for the peak value of the first wave is different from that shown in the table, a circuit breaker must be separately selected.

3-phase 210V

Table 4-21-3 MCCB

Transformer capacity kVA	Rated primary current A	Example of transformer excited inrush current ①			Example of transformer excited inrush current ②			Example of transformer excited inrush current ③		
		Peak value of first wave (multiple)	Model	Rating A	Peak value of first wave (multiple)	Model	Rating A	Peak value of first wave (multiple)	Model	Rating A
5	13.7	25	NF32-SV NF63-CV, NF63-SV, NF63-HV NF125-SV, NF125-HV	20 20 20	26	NF32-SV, NF63-CV, NF63-SV NF125-SV	20 20	18	NF32-SV, NF63-CV, NF63-SV NF125-SV	20 20
7.5	20.6	25	NF63-CV(*1) NF63-CV, NF63-SV, NF63-HV NF125-CV(*2) NF125-SV, NF125-HV	30 50 (50) 50	26	NF63-CV(*1) NF63-CV, NF63-SV NF125-CV, NF125-SV	30 50 50	18	NF32-SV, NF63-CV, NF63-SV NF125-CV(*2) NF125-SV	30 (50) 30
10	27.5	24	NF63-CV(*1) NF63-CV, NF63-SV, NF63-HV NF125-CV(*1) NF125-SV, NF125-HV	40 60 50 60	26	NF63-CV(*1) NF63-CV, NF63-SV NF125-CV, NF125-SV	40 60 60	18	NF63-CV, NF63-SV NF125-CV(*2) NF125-SV	50 (50) 50
15	41.2	24	NF63-CV(*1) NF125-CV, NF125-SV, NF125-HV	50 100	26	NF125-CV(*1) NF125-CV, NF125-SV	60 100	18	NF63-CV(*1) NF63-CV, NF63-SV NF125-CV, NF125-SV	50 60 60
20	55.0	20	NF125-CV(*1) NF125-CV, NF125-SV, NF125-HV	75 100	26	NF125-CV(*1) NF125-SEV NF250-CV, NF250-SV	75 75 125	18	NF125-CV(*1) NF125-CV, NF125-SV	75 100
30	82.5	20	NF125-CV(*1) NF250-CV, NF250-SV, NF250-HV NF250-SEV, NF250-HEV	100 150 125	26	NF250-CV, NF250-SV NF250-SEV	200 125	18	NF125-CV(*1) NF250-CV, NF250-SV	100 150
50	137	20	NF250-SEV, NF250-HEV NF400-CW NF400-SW	175 350 250	23	NF400-CW NF400-SW NF400-SEW	400 300 200	16	NF250-CV, NF250-SV NF250-SEV	200 175
75	206	21	NF400-SW NF400-SEW, NF400-HEW	400 250	18	NF400-SW NF400-SEW	350 250	14	NF400-SW NF400-SEW	300 250
100	275	21	NF400-SEW(*1) NF630-SW NF630-SEW, NF630-HEW	350 600 350	17	NF400-SEW	350	13	NF400-SW NF400-SEW	350 300
150	412	17	NF630-SEW, NF630-HEW	500	14	NF630-SEW	500	13	NF630-SW NF630-SEW	500 500
200	550	16	NF800-SEW(*1)	700	13	NF800-SEW	700	12	NF800-SEW	700
300	825	16	NF1600-SEW	1000	13	NF1250-SEW	1000	12	NF1000-SEW	1000
500	1375	-	-	-	11	NF1600-SEW	1600	11	NF1600-SEW	1600

Table 4-21-4 ELCB

Transformer capacity kVA	Rated primary current A	Example of transformer excited inrush current ①			Example of transformer excited inrush current ②			Example of transformer excited inrush current ③		
		Peak value of first wave (multiple)	Model	Rating A	Peak value of first wave (multiple)	Model	Rating A	Peak value of first wave (multiple)	Model	Rating A
5	13.7	25	NV32-SV NV63-CV, NV63-SV, NV63-HV NV125-SV, NV125-HV	20 20 20	26	NV32-SV NV63-CV, NV63-SV NV125-SV	20 20 20	18	NV32-SV NV63-CV, NV63-SV NV125-SV	20 20 20
7.5	20.6	25	NV63-CV, NV63-SV, NV63-HV NV125-CV NV125-SV, NV125-HV	50 60 50	26	NV63-CV, NV63-SV NV125-CV NV125-SV	50 60 50	18	NV32-SV NV63-CV, NV63-SV NV125-SV	30 30 30
10	27.5	24	NV63-CV, NV63-SV, NV63-HV NV125-CV, NV125-SV, NV125-HV	60 60	26	NV63-CV, NV63-SV NV125-CV, NV125-SV	60 60	18	NV63-CV, NV63-SV NV125-CV NV125-SV	50 60 50
15	41.2	24	NV125-CV, NV125-SV, NV125-HV NV125-SEV, NV125-HEV	100 50	26	NV125-CV, NV125-SV NV125-SEV	100 50	18	NV63-CV, NV63-SV NV125-CV, NV125-SV	60 60
20	55.0	20	NV125-CV, NV125-SV, NV125-HV NV125-SEV, NV125-HEV	100 75	26	NV125-SEV NV250-CV, NV250-SV	75 125	18	NV125-CV, NV125-SV NV125-SEV	100 75
30	82.5	20	NV250-CV, NV250-SV, NV250-HV NV250-SEV, NV250-HEV	150 125	26	NV250-CV, NV250-SV NV250-SEV	200 125	18	NV250-CV, NV250-SV NV125-SEV	150 125
50	137	20	NV250-SEV, NV250-HEV NV400-CW NV400-SW	175 350 250	23	NV400-CW NV400-SW NV400-SEW	400 300 200	16	NV250-CV, NV250-SV NV250-SEV	200 175
75	206	21	NV400-SW NV400-SEW, NV400-HEW	400 250	18	NV400-SW NV400-SEW	250 350	14	NV400-SW NV400-SEW	300 250
100	275	21	NV630-SEW, NV630-HEW NV800-SEW, NV800-HEW	350 400	17	NV400-SEW	350	13	NV400-SW NV400-SEW	350 300
150	412	17	NV630-SEW, NV630-HEW	500	14	NV630-SEW NV800-SEW	500 500	13	NV630-SEW NV800-SEW	500 500
200	550	16	-	-	13	-	-	12	NV800-SEW	700
300	825	16	-	-	13	-	-	12	-	-
500	1375	-	-	-	11	-	-	11	-	-

Notes \*1 Examples of selection of high-instantaneous circuit breakers (special models) for primary side of transformer.

\*2 The circuit breakers with rating in parentheses are special models.

Remarks: 1. For the circuit breakers whose rated current is adjustable, the rated current values are shown.

2. The peak value of the first wave of excited inrush current shall be calculated based on the multiple for the peak value of the first wave in the table, and the calculated value shall not exceed the lower limit peak value of instantaneous tripping current of circuit breaker. The circuit breakers are selected on condition that the transformer rated current value does not exceed 0.9 times the circuit breaker rated current. If the multiple for the peak value of the first wave is different from that shown in the table, a circuit breaker must be separately selected.

# 4 Selection 2 Selection of MCCB and ELCB

## 3-phase 420V

Table 4-21-5 MCCB

Transformer capacity kVA	Rated primary current A	Example of transformer excited inrush current ①			Example of transformer excited inrush current ②			Example of transformer excited inrush current ③				
		Peak value of first wave (multiple)	Model	Rating A	Peak value of first wave (multiple)	Model	Rating A	Peak value of first wave (multiple)	Model	Rating A		
5	6.9	32	NF32-SV	10	26	NF32-SV, NF63-CV, NF63-SV	10	18	NF32-SV, NF63-CV, NF63-SV	10		
			NF63-CV, NF63-SV, NF63-HV	10							NF125-SV	15
			NF125-SV, NF125-HV	15								
7.5	10.3	32	NF32-SV	15	26	NF32-SV, NF63-CV, NF63-SV	15	18	NF32-SV, NF63-CV, NF63-SV	15		
			NF63-CV, NF63-SV, NF63-HV	15							NF125-SV	15
			NF125-SV, NF125-HV	15								
10	13.7	31	NF32-SV	20	26	NF32-SV, NF63-CV, NF63-SV	20	18	NF32-SV, NF63-CV, NF63-SV	20		
			NF63-CV, NF63-SV, NF63-HV	20							NF125-SV	20
			NF125-CV(*2)	(50)							NF125-SV	20
			NF125-SV, NF125-HV	20								
15	20.6	31	NF63-CV(*1)	40	26	NF63-CV(*1)	30	18	NF32-SV, NF63-CV, NF63-SV	30		
			NF63-CV, NF63-SV, NF63-HV	60							NF63-CV, NF63-SV	50
			NF125-CV, NF125-SV, NF125-HV	60							NF125-CV, NF125-SV	50
			NF125-SEV, NF125-HEV	50								
			NF63-CV(*1)	40								
20	27.5	26	NF63-CV(*1)	40	26	NF63-CV(*1)	40	18	NF63-CV(*1)	40		
			NF63-CV, NF63-SV, NF63-HV	60							NF63-CV, NF63-SV	50
			NF125-CV(*1)	50							NF125-CV, NF125-SV	50
			NF125-SV, NF125-HV	60								
30	41.2	24	NF63-CV(*1)	50	26	NF125-CV(*1)	60	18	NF63-CV(*1)	50		
			NF125-CV(*1)	50							NF125-CV, NF125-SV	75
			NF125-SV, NF125-HV	100								
50	68.7	22	NF125-CV(*1)	100	23	NF125-CV(*1)	100	16	NF125-CV, NF125-SV	100		
			NF250-CV, NF250-SV, NF250-HV	150							NF250-CV, NF250-SV	150
			NF250-SEV, NF250-HEV	125								
75	103	15	NF250-CV, NF250-SV, NF250-HV	150	18	NF250-CV, NF250-SV	175	14	NF250-CV, NF250-SV	150		
			NF250-SEV, NF250-HEV	125								
100	137	15	NF250-CV, NF250-SV, NF250-HV	200	17	NF250-CV, NF250-SV	200	13	NF250-CV, NF250-SV	175		
			NF250-SEV, NF250-HEV	175								
150	206	15	NF400-CW	400	14	NF400-SW	300	13	NF400-CW	400		
			NF400-SW	300							NF400-SW	250
			NF400-SEW, NF400-HEW	250							NF400-SEW	250
200	275	14	NF400-SW	350	13	NF400-SW/SEW	350/350	12	NF400-SW	350		
			NF400-SEW, NF400-HEW	350							NF400-SEW	350
300	412	10	NF630-CW	600	13	NF630-SEW	500	12	NF630-SW	500		
			NF630-SW	500							NF630-SEW	500
			NF630-SEW, NF630-HEW	500								
500	687	15	NF800-SEW(*1)	800	11	NF800-SEW	800	11	NF800-SEW	800		
			NF1250-SEW	800								

Table 4-21-6 ELCB

Transformer capacity kVA	Rated primary current A	Example of transformer excited inrush current ①			Example of transformer excited inrush current ②			Example of transformer excited inrush current ③				
		Peak value of first wave (multiple)	Model	Rating A	Peak value of first wave (multiple)	Model	Rating A	Peak value of first wave (multiple)	Model	Rating A		
5	6.9	32	NV32-SV	15	26	NV32-SV	15	18	NV32-SV	15		
			NV63-CV, NV63-SV	15(10)							NV63-CV, NV63-SV	15(10)
			NV63-HV	15							NV125-SV	15
			NV125-SV, NV125-HV	15								
7.5	10.3	32	NV32-SV	15	26	NV32-SV	15	18	NV32-SV	15		
			NV63-CV, NV63-SV, NV63-HV	15							NV63-CV, NV63-SV	15
			NV125-SV, NV125-HV	15							NV125-SV	15
10	13.7	31	NV32-SV	20	26	NV32-SV	20	18	NV32-SV	20		
			NV63-CV, NV63-SV, NV63-HV	20							NV63-CV, NV63-SV	20
			NV125-CV	50							NV125-SV	20
			NV125-SV, NV125-HV	20								
15	20.6	31	NV63-CV, NV63-SV, NV63-HV	60	26	NV63-CV, NV63-SV	50	18	NV32-SV	30		
			NV125-CV, NV125-SV, NV125-HV	60							NV125-CV	30
			NV125-SEV, NV125-HEV	50							NV125-SV	30
			NV63-CV, NV63-SV, NV63-HV	60								
20	27.5	26	NV63-CV, NV63-SV, NV63-HV	60	26	NV63-CV, NV63-SV	60	18	NV63-CV, NV63-SV	50		
			NV125-CV, NV125-SV, NV125-HV	60							NV125-CV, NV125-SV	50
30	41.2	24	NV125-CV, NV125-SV, NV125-HV	100	26	NV125-CV, NV125-SV	100	18	NV125-CV, NV125-SV	75		
			NV125-SEV, NV125-HEV	50								
50	68.7	22	NV250-CV, NV250-SV, NV250-HV	150	23	NV250-CV, NV250-SV	150	16	NV125-CV, NV125-SV	100		
			NV250-SEV, NV250-HEV	125								
75	103	15	NV250-CV, NV250-SV, NV250-HV	150	18	NV250-CV, NV250-SV	175	14	NV250-CV, NV250-SV	150		
			NV250-SEV, NV250-HEV	125								
100	137	15	NV250-CV, NV250-SV, NV250-HV	200	17	NV250-CV, NV250-SV	200	13	NV250-CV, NV250-SV	175		
			NV250-SEV, NV250-HEV	175								
150	206	15	NV400-CW	400	14	NV400-SW	300	13	NV400-CW	400		
			NV400-SW	300							NV400-SW	250
			NV400-SEW, NV400-HEW	250							NV400-SEW	250
200	275	14	NV400-SW	350	13	NV400-SW	350	12	NV400-SW	350		
			NV400-SEW, NV400-HEW	350							NV400-SEW	350
300	412	10	NV630-CW, NV630-SW	600	13	NV630-SEW	500	12	NV630-SEW	500		
			NV630-SEW, NV630-HEW	500								
500	687	15	-	-	11	-	-	11	-	-		

Notes \*1 Examples of selection of high-instantaneous circuit breakers (special models) for primary side of transformer.

\*2 The circuit breakers with rating in parentheses are special models.

Remarks: 1. For the circuit breakers whose rated current is adjustable, the rated current values are shown.

2. The peak value of the first wave of excited inrush current shall be calculated based on the multiple for the peak value of the first wave in the table, and the calculated value shall not exceed the lower limit peak value of instantaneous tripping current of circuit breaker. The circuit breakers are selected on condition that the transformer rated current value does not exceed 0.9 times the circuit breaker rated current. If the multiple for the peak value of the first wave is different from that shown in the table, a circuit breaker must be separately selected.

# 10. Combination for Selective Breaking

Combinations of main circuit breaker for coordination and branch circuit breakers capable of selective breaking and the breaking capacity (sym kA) for selective breaking at the installation point of the branch circuit breaker are shown below.

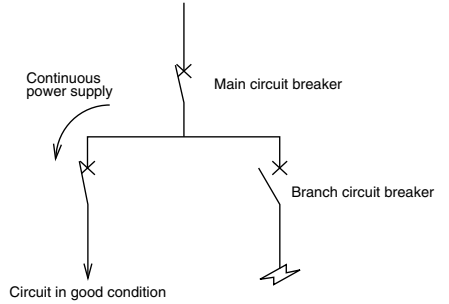

**Table 4-22-1 Combination for selective breaking 440VAC (IEC 60947-2)**

sym.kA

Branch breaker	Main breaker Icu(kA)	Circuit breaker													
		NF125-SEV	NF125-HEV	NF250-SEV	NF250-HEV	NF400-SEV	NF400-HEV	NF630-SEV	NF630-HEV	NF800-CEW	NF800-SEW	NF800-HEW	NF1000-SEW	NF1250-SEW	NF1600-SEW
NF32-SV	2.5	1.5	1.5	2.5	2.5	2.5	2.5	2.5	2.5	2.5	2.5	2.5	2.5	2.5	2.5
NV32-SV	5	1.5	1.5	2.5	2.5	5	5	5	5	5	5	5	5	5	5
NF63-SV	7.5	1.5	1.5	2.5	2.5	7.5	7.5	7.5	7.5	7.5	7.5	7.5	7.5	7.5	7.5
NV63-SV	10	1.5	1.5	2.5	2.5	7.5	7.5	10	10	10	10	10	10	10	10
NF63-HV	10	1.5	1.5	2.5	2.5	7.5	7.5	10	10	10	10	10	10	10	10
NV63-HV	10	1.5	1.5	2.5	2.5	7.5	7.5	10	10	10	10	10	10	10	10
NF125-SV	25	-	-	2.5	2.5	5	5	10	10	10	10	10	10	10	22
NF125-SEV	25	-	-	2.5	2.5	5	5	10	10	10	10	10	10	10	22
NV125-SV	25	-	-	2.5	2.5	5	5	10	10	10	10	10	10	10	22
NV125-SEV	25	-	-	2.5	2.5	5	5	10	10	10	10	10	10	10	22
NF125-SGV	36	-	-	2.5	2.5	7.5	7.5	15	15	15	15	15	15	15	36
NF125-LGV	50	-	-	2.5	2.5	7.5	7.5	15	15	15	15	15	15	15	42
NF125-HV	50	-	-	2.5	2.5	7.5	7.5	18	18	18	18	18	18	18	50
NV125-HV	50	-	-	2.5	2.5	7.5	7.5	18	18	18	18	18	18	18	50
NF125-HGV	65	-	-	2.5	2.5	7.5	7.5	15	15	15	15	15	15	15	42
NF160-SGV	36	-	-	-	-	6.4	6.4	10	10	10	10	10	10	10	25
NF160-LGV	50	-	-	-	-	6.4	6.4	10	10	15	15	15	15	15	25
NF160-HGV	65	-	-	-	-	6.4	6.4	10	10	15	15	15	15	15	25
NF250-SV	36	-	-	-	-	-	-	10	10	10	10	10	10	10	22
NF250-SEV	36	-	-	-	-	-	-	10	10	10	10	10	10	10	22
NV250-SV	36	-	-	-	-	-	-	10	10	10	10	10	10	10	22
NV250-SEV	36	-	-	-	-	-	-	10	10	10	10	10	10	10	22
NF250-SGV	36	-	-	-	-	-	-	10	10	10	10	10	10	10	25
NF250-LGV	50	-	-	-	-	-	-	10	10	15	15	15	15	15	25
NF250-HV	65	-	-	-	-	-	-	10	10	15	15	15	15	15	25
NF250-HEV	65	-	-	-	-	-	-	10	10	15	15	15	15	15	25
NV250-HV	65	-	-	-	-	-	-	10	10	15	15	15	15	15	25
NV250-HEV	65	-	-	-	-	-	-	10	10	15	15	15	15	15	25
NF400-SW	42	-	-	-	-	-	-	-	13	13	13	13	13	13	20
NV400-SW	42	-	-	-	-	-	-	-	13	13	13	13	13	13	20
NF400-SEW	42	-	-	-	-	-	-	9.5	9.5	13	13	13	13	13	20
NV400-SEW	42	-	-	-	-	-	-	9.5	9.5	13	13	13	13	13	20
NF400-HEW	65	-	-	-	-	-	-	9.5	9.5	10	10	10	13	20	20
NV400-HEW	65	-	-	-	-	-	-	9.5	9.5	10	10	10	13	20	20
NF400-REW	125	-	-	-	-	-	-	9.5	9.5	10	10	10	13	20	20
NF630-SW	42	-	-	-	-	-	-	-	-	-	-	-	-	-	20
NF630-SEW	42	-	-	-	-	-	-	-	-	-	-	-	-	-	20
NV630-SW	42	-	-	-	-	-	-	-	-	-	-	-	-	-	20
NV630-SEW	42	-	-	-	-	-	-	-	-	-	-	-	-	-	20
NF630-HEW	65	-	-	-	-	-	-	-	-	-	-	-	-	-	20
NV630-HEW	65	-	-	-	-	-	-	-	-	-	-	-	-	-	20
NF63-CV	2.5	1.5	1.5	2.5	2.5	2.5	2.5	2.5	2.5	2.5	2.5	2.5	7.5	2.5	2.5
NV63-CV	2.5	1.5	1.5	2.5	2.5	2.5	2.5	2.5	2.5	2.5	2.5	2.5	7.5	2.5	2.5
NF125-CV	10	-	-	2.5	2.5	5	5	10	10	10	10	10	15	10	10
NV125-CV	10	-	-	2.5	2.5	5	5	10	10	10	10	10	15	10	10
NF250-CV	15	-	-	-	-	-	-	7.5	7.5	7.5	7.5	7.5	7.5	15	15
NV250-CV	15	-	-	-	-	-	-	7.5	7.5	7.5	7.5	7.5	7.5	15	15
NF400-CW	25	-	-	-	-	-	-	-	10	10	10	13	20	20	20
NV400-CW	25	-	-	-	-	-	-	-	10	10	10	13	20	20	20
NF630-CW	36	-	-	-	-	-	-	-	-	-	-	-	-	-	20
NV630-CW	36	-	-	-	-	-	-	-	-	-	-	-	-	-	20
NF125-RGV	125	-	-	2.5	2.5	15	15	30	30	30	42	50	50	85	85
NF125-UV	200	-	-	2.5	2.5	15	15	30	30	30	42	50	50	85	85
NF250-RGV	125	-	-	-	-	-	-	15	15	15	25	25	25	85	85
NF250-UV	200	-	-	-	-	-	-	15	15	15	25	25	25	85	85
NF400-UEW	200	-	-	-	-	-	-	9.5	9.5	15	15	15	15	25	25
NF800-UEW	200	-	-	-	-	-	-	-	-	-	-	-	-	-	-

Note \*1 Rated currents of branch breakers are 50A or less.  
Remarks: 1. It is considered that the instantaneous tripping characteristic values of main circuit breakers have been set to the maximum values.  
2. For the selectivity in the overcurrent range, separately check the coordination on the operating characteristic curve.

**230VAC (IEC 60947-2)**

sym.kA

Branch breaker	Main breaker Icu(kA)	Circuit breaker													
		NF125-SEV	NF125-HEV	NF250-SEV	NF250-HEV	NF400-SEV	NF400-HEV	NF630-SEV	NF630-HEV	NF800-CEW	NF800-SEW	NF800-HEW	NF1000-SEW	NF1250-SEW	NF1600-SEW
NF32-SV	7.5	1.5	1.5	2.5	2.5	5	5	7.5	7.5	7.5	7.5	7.5	7.5	7.5	7.5
NV32-SV	10	1.5	1.5	2.5	2.5	10	10	10	10	10	10	10	10	10	10
NF63-SV	15	1.5	1.5	2.5	2.5	10	10	10	10	10	10	10	10	10	10
NV63-SV	15	1.5	1.5	2.5	2.5	10	10	10	10	10	10	10	10	10	10
NF63-HV	25	1.5	1.5	2.5	2.5	10	10	20	20	25	25	25	25	25	25
NV63-HV	25	1.5	1.5	2.5	2.5	10	10	20	20	25	25	25	25	25	25
NF125-SV	50	-	-	2.5	2.5	7.5	7.5	15	15	18	18	18	18	18	50
NF125-SEV	50	-	-	2.5	2.5	7.5	7.5	15	15	18	18	18	18	18	50
NV125-SV	50	-	-	2.5	2.5	7.5	7.5	15	15	18	18	18	18	18	50
NV125-SEV	50	-	-	2.5	2.5	7.5	7.5	15	15	18	18	18	18	18	50
NF125-SGV	85	-	-	2.5	2.5	7.5	7.5	15	15	18	18	18	18	18	85
NF125-LGV	90	-	-	2.5	2.5	7.5	7.5	15	15	18	18	18	18	18	85
NF125-HV	100	-	-	2.5	2.5	10	10	25	25	35	35	35	35	35	100
NV125-HV	100	-	-	2.5	2.5	10	10	25	25	35	35	35	35	35	100
NF125-HGV	100	-	-	2.5	2.5	7.5	7.5	15	15	18	18	18	18	18	85
NF160-SGV	85	-	-	-	-	6.4	6.4	10	10	10	10	10	10	10	50
NF160-LGV	90	-	-	-	-	6.4	6.4	10	10	10	10	10	10	10	50
NF160-HGV	100	-	-	-	-	6.4	6.4	10	10	10	10	10	10	10	50
NF250-SV	85	-	-	-	-	-	-	10	10	10	10	10	10	10	50
NF250-SEV	85	-	-	-	-	-	-	10	10	10	10	10	10	10	50
NV250-SV	85	-	-	-	-	-	-	10	10	10	10	10	10	10	50
NV250-SEV	85	-	-	-	-	-	-	10	10	10	10	10	10	10	50
NF250-SGV	85	-	-	-	-	-	-	10	10	10	10	10	10	10	50
NF250-LGV	90	-	-	-	-	-	-	10	10	10	10	10	10	10	50
NF250-HV	100	-	-	-	-	-	-	10	10	10	10	10	10	10	50
NF250-HEV	100	-	-	-	-	-	-	10	10	10	10	10	10	10	50
NV250-HV	100	-	-	-	-	-	-	10	10	10	10	10	10	10	50
NV250-HEV	100	-	-	-	-	-	-	10	10	10	10	10	10	10	50
NF400-SW	85	-	-	-	-	-	-	-	-	13	13	13	13	13	20
NV400-SW	85	-	-	-	-	-	-	-	-	13	13	13	13	13	20
NF400-SEW	85	-	-	-	-	-	-	-	-	13	13	13	13	13	20
NV400-SEW	85	-	-	-	-	-	-	-	-	13	13	13	13	13	20
NF400-HEW	100	-	-	-	-	-	-	-	-	13	13	13	13	13	20
NV400-HEW	100	-	-	-	-	-	-	-	-	13	13	13	13	13	20
NF400-REW	150	-	-	-	-	-	-	9.5	9.5	13	13	13	13	13	20
NF630-SW	85	-	-	-	-	-	-	-	-	-	-	-	-	-	20
NF630-SEW	85	-	-	-	-	-	-	-	-	-	-	-	-	-	20
NV630-SW	85	-	-	-	-	-	-	-	-	-	-	-	-	-	20
NV630-SEW	85	-	-	-	-	-	-	-	-	-	-	-	-	-	20
NF630-HEW	100	-	-	-	-	-	-	-	-	-	-	-	-	-	20
NV630-HEW	100	-	-	-	-	-	-	-	-	-	-	-	-	-	20
NF63-CV	7.5	1.5	1.5	2.5	2.5	7.5	7.5	7.5	7.5	7.5	7.5	7.5	7.5	7.5	7.5
NV63-CV	7.5	1.5	1.5	2.5	2.5	7.5	7.5								

# 4 Selection 2 Selection of MCCB and ELCB

Table 4-22-2 Combination for selective breaking with AE-SW Series

440VAC (IEC 60947-2)

sym.kA

230VAC (IEC 60947-2)

sym.kA

Rated ultimate short-circuit breaking capacity of each breaker	Main breaker	Low-voltage air circuit breaker AE-SW								
		AE630-SW	AE1000-SW	AE1250-SW	AE1600-SW	AE2000-SWA	AE2000-SW	AE2500-SW	AE3200-SW	AE4000-SWA
Branch breaker	Icu(kA)	65	65	65	65	65	85	85	85	85
NF	NF32-SV	2.5	2.5	2.5	2.5	2.5	2.5	2.5	2.5	2.5
	NV32-SV	5	5	5	5	5	5	5	5	5
	NF63-SV	7.5	7.5	7.5	7.5	7.5	7.5	7.5	7.5	7.5
	NV63-SV	7.5	7.5	7.5	7.5	7.5	7.5	7.5	7.5	7.5
	NF63-HV	10	9(10)	10	10	10	10	10	10	10
	NV63-HV	10	9(10)	10	10	10	10	10	10	10
	NF125-SV	25	7(25)	20(25)	25	25	25	25	25	25
	NV125-SV	25	7(25)	20(25)	25	25	25	25	25	25
	NF125-SEV	36	7(36)	20(36)	25(36)	30(36)	36	36	36	36
	NV125-SEV	36	7(36)	20(36)	25(36)	30(36)	36	36	36	36
NF	NF125-SGV	36	9(36)	20(36)	36	36	36	36	36	36
	NV125-SGV	36	9(36)	20(36)	36	36	36	36	36	36
	NF125-LGV	50	9(50)	20(50)	36(50)	50	50	50	50	50
	NV125-LGV	50	9(50)	20(50)	36(50)	50	50	50	50	50
	NF125-HV	50	9(50)	30(50)	50	50	50	50	50	50
	NV125-HV	50	9(50)	30(50)	50	50	50	50	50	50
	NF125-HGV	65	9(65)	20(65)	36(65)	65	65	65	65	65
	NV125-HGV	65	9(65)	20(65)	36(65)	65	65	65	65	65
	NF160-LGV	50	9(50)	15(50)	25(50)	42(50)	42(50)	50	50	50
	NV160-LGV	50	9(50)	15(50)	25(50)	42(50)	42(50)	50	50	50
NF	NF160-HGV	65	9(65)	15(65)	25(65)	42(65)	42(65)	65	65	65
	NV160-HGV	65	9(65)	15(65)	25(65)	42(65)	42(65)	65	65	65
	NF250-SV	36	7(36)	14(36)	19(36)	25(36)	25(36)	36	36	36
	NV250-SV	36	7(36)	14(36)	19(36)	25(36)	25(36)	36	36	36
	NF250-SGV	36	7(36)	15(36)	25(36)	36	36	36	36	36
	NV250-SGV	36	7(36)	15(36)	25(36)	36	36	36	36	36
	NF250-LGV	50	7(50)	15(50)	25(50)	42(50)	42(50)	50	50	50
	NV250-LGV	50	7(50)	15(50)	25(50)	42(50)	42(50)	50	50	50
	NF250-HV	65	7(65)	15(65)	25(65)	42(65)	42(65)	65	65	65
	NV250-HV	65	7(65)	15(65)	25(65)	42(65)	42(65)	65	65	65
NF	NF250-HEV	65	7(65)	15(65)	25(65)	42(65)	42(65)	65	65	65
	NV250-HEV	65	7(65)	15(65)	25(65)	42(65)	42(65)	65	65	65
	NF250-HGV	65	7(65)	15(65)	25(65)	42(65)	42(65)	65	65	65
	NV250-HGV	65	7(65)	15(65)	25(65)	42(65)	42(65)	65	65	65
	NF400-SW	42	-	-	18(42)	24(42)	24(42)	33(42)	42	42
	NV400-SW	42	-	-	18(42)	24(42)	24(42)	33(42)	42	42
	NF400-SEW	42	9(42)	15(42)	18(42)	24(42)	24(42)	30(42)	39(42)	42
	NV400-SEW	42	9(42)	15(42)	18(42)	24(42)	24(42)	30(42)	39(42)	42
	NF400-HEW	65	9(65)	15(65)	18(65)	24(65)	24(65)	30(65)	39(65)	65
	NV400-HEW	65	9(65)	15(65)	18(65)	24(65)	24(65)	30(65)	39(65)	65
NF	NF400-REW	125	9(65)	15(65)	18(65)	24(65)	24(65)	30(75)	39(75)	80
	NV400-REW	125	9(65)	15(65)	18(65)	24(65)	24(65)	30(75)	39(75)	80
	NF630-SW	42	-	-	-	24(42)	24(42)	30(42)	37(42)	42
	NV630-SW	42	-	-	-	24(42)	24(42)	30(42)	37(42)	42
	NF630-SEW	65	-	15(65)	18(65)	24(65)	24(65)	30(65)	37(65)	48(65)
	NV630-SEW	65	-	15(65)	18(65)	24(65)	24(65)	30(65)	37(65)	48(65)
	NF800-SW	42	-	-	18(42)	24(42)	24(42)	30(42)	37(42)	42
	NV800-SW	42	-	-	18(42)	24(42)	24(42)	30(42)	37(42)	42
	NF800-HEW	65	-	-	18(65)	24(65)	24(65)	30(65)	37(65)	48(65)
	NV800-HEW	65	-	-	18(65)	24(65)	24(65)	30(65)	37(65)	48(65)
NF	NF63-CV	2.5	2.5	2.5	2.5	2.5	2.5	2.5	2.5	2.5
	NV63-CV	2.5	2.5	2.5	2.5	2.5	2.5	2.5	2.5	2.5
	NF125-CV	10	9(10)	10	10	10	10	10	10	10
	NV125-CV	10	9(10)	10	10	10	10	10	10	10
	NF250-CV	15	9(15)	15	15	15	15	15	15	15
	NV250-CV	15	9(15)	15	15	15	15	15	15	15
	NF400-CW	25	-	15(25)	18(25)	25	25	25	25	25
	NV400-CW	25	-	15(25)	18(25)	25	25	25	25	25
	NF630-CW	36	-	-	-	24(36)	24(36)	30(42)	36	36
	NV630-CW	36	-	-	-	24(36)	24(36)	30(42)	36	36
NF	NF800-CEW	36	-	-	18(36)	24(36)	24(36)	30(42)	36	36
	NV800-CEW	36	-	-	18(36)	24(36)	24(36)	30(42)	36	36
	NF125-RGV	125	35(65)	65	65	65	85	85	85	85
	NV125-RGV	200	50(65)	65	65	65	85	85	85	85
	NF250-RGV	125	9(65)	50(65)	65	65	85	85	85	85
	NV250-RGV	200	9(65)	50(65)	65	65	85	85	85	85
	NF400-UEW	200	9(65)	15(65)	18(65)	29(65)	29(65)	48(75)	85	85
	NV400-UEW	200	9(65)	15(65)	18(65)	29(65)	29(65)	48(75)	85	85
	NF800-UEW	200	-	-	18(65)	24(65)	24(65)	30(75)	37(75)	68(75)
	NV800-UEW	200	-	-	18(65)	24(65)	24(65)	30(75)	37(75)	68(75)

Rated ultimate short-circuit breaking capacity of each breaker	Main breaker	Low-voltage air circuit breaker AE-SW								
		AE630-SW	AE1000-SW	AE1250-SW	AE1600-SW	AE2000-SWA	AE2000-SW	AE2500-SW	AE3200-SW	AE4000-SWA
Branch breaker	Icu(kA)	65	65	65	65	65	85	85	85	85
NF	NF32-SV	7.5	7.5	7.5	7.5	7.5	7.5	7.5	7.5	7.5
	NV32-SV	10	9(10)	10	10	10	10	10	10	10
	NF63-SV	15	9(10)	15	15	15	15	15	15	15
	NV63-SV	15	9(10)	15	15	15	15	15	15	15
	NF63-HV	25	9(25)	25	25	25	25	25	25	25
	NV63-HV	25	9(25)	25	25	25	25	25	25	25
	NF125-SV	50	9(50)	45(50)	50	50	50	50	50	50
	NV125-SV	50	9(50)	45(50)	50	50	50	50	50	50
	NF125-SEV	85	9(65)	45(65)	50(65)	50(65)	50(65)	85	85	85
	NV125-SEV	85	9(65)	45(65)	50(65)	50(65)	50(65)	85	85	85
NF	NF125-SGV	85	16(65)	45(65)	65	65	65	85	85	85
	NV125-SGV	85	16(65)	45(65)	65	65	65	85	85	85
	NF125-LGV	90	16(65)	45(65)	65	65	65	85	85	85
	NV125-LGV	90	16(65)	45(65)	65	65	65	85	85	85
	NF125-HV	100	9(65)	50(65)	65	65	65	85	85	85
	NV125-HV	100	9(65)	50(65)	65	65	65	85	85	85
	NF125-HGV	100	16(65)	45(65)	65	65	65	85	85	85
	NV125-HGV	100	16(65)	45(65)	65	65	65	85	85	85
	NF160-LGV	90	9.4(65)	25(65)	40(65)	65	65	85	85	85
	NV160-LGV	90	9.4(65)	25(65)	40(65)	65	65	85	85	85
NF	NF160-HGV	100	9.4(65)	25(65)	40(65)	65	65	85	85	85
	NV160-HGV	100	9.4(65)	25(65)	40(65)	65	65	85	85	85
	NF250-SV	36	7(36)	14(36)	19(36)	25(36)	25(36)	36	36	36
	NV250-SV	36	7(36)	14(36)	19(36)	25(36)	25(36)	36	36	36
	NF250-SGV	85	9.4(65)	25(65)	40(65)	65	65	85	85	85
	NV250-SGV	85	9.4(65)	25(65)	40(65)	65	65	85	85	85
	NF250-LGV	90	9.4(65)	25(65)	40(65)	65	65	85	85	85
	NV250-LGV	90	9.4(65)	25(65)	40(65)	65	65	85	85	85
	NF250-HV	100	9(65)	25(65)	40(65)	65	65	85	85	85
	NV250-HV	100	9(65)	25(65)	40(65)	65	65	85	85	85
NF	NF250-HEV	100	9(65)	25(65)	40(65)	65	65	85	85	85
	NV250-HEV	100	9(65)	25(65)	40(65)	65	65	85	85	85
	NF250-HGV	100	9.4(65)	25(65)	40(65)	65	65	85	85	85
	NV250-HGV	100	9.4(65)	25(65)	40(65)	65	65	85	85	85
	NF400-SW	85	-	-	20(65)	30(65)	30(65)	48(75)	70(75)	85
	NV400-SW	85	-	-	20(65)	30(65)	30(65)	48(75)	70(75)	85
	NF400-SEW	85	9(65)	15(65)	20(65)	30(65)	30(65)	48(75)	70(75)	85
	NV400-SEW	85	9(65)	15(65)	20(65)	30(65)	30(65)	48(75)	70(75)	85
	NF400-HEW	100	9(65)	15(65)	20(65)	30(65)	30(65)	48(75)	70(75)	85
	NV400-HEW	100	9(65)	15(65)	20(65)	30(65)	30(65)	48(75)	70(75)	85
NF	NF400-REW	150	9(65)	15(65)	20(65)	30(65)	30(65)	48(75)	70(75)	85
	NV400-REW	150	9(65)	15(65)	20(65)	30(65)	30(65)	48(75)	70(75)	85
	NF630-SW	85	-	-	-	24(65)	24(65)	30(75)	40(75)	60(75)
	NV630-SW	85	-	-	-	24(65)	24(65)	30(75)	40(75)	60(75)
	NF630-SEW	100	-	15(65)	18(65)	24(65)	24(65)	30(75)	40(75)	60(75)
	NV630-SEW	100	-	15(65)	18(65)	24(65)	24(65)	30(75)	40(75)	60(75)
	NF800-SW	85	-	-	18(65)	24(65)	24(65)	30(75)	40(75)	60(75)
	NV800-SW	85	-	-	18(65)	24(65)	24(65)	30(75)	40(75)	60(75)
	NF800-HEW	100	-	-	18(65)	24(65)	24(65)	30(75)	40(75)	60(75)
	NV800-HEW	100	-	-	18(65)	24(65)	24(65)	30(75)	40(75)	60(75)
NF	NF63-CV	7.5	7.5	7.5	7.5	7.5	7.5	7.5	7.5	7.5
	NV63-CV	7.5	7.5	7.5	7.5	7.5	7.5	7.5	7.5	7.5
	NF125-CV	30	9(30)	15(30)	18(30)	24(30)	24(30)	30	30	30
	NV125-CV	30	9(30)	15(30)	18(30)	24(30)	24(30)	30	30	30
	NF250-CV	36	9(36)	15(36)	18(36)	24(36)	24(36)	36	36	36
	NV250-CV	36	9(36)	15(36)	18(36)	24(36)	24(36)	36	36	36
	NF400-CW	50	-	15(50)	20(					

# 11. Combinations for Cascade Breaking

The following tables show the combinations of circuit breakers capable of cascade breaking and the cascade breaking capacities (symmetrical values, sym kA). The criteria conform to IEC 60947-2.

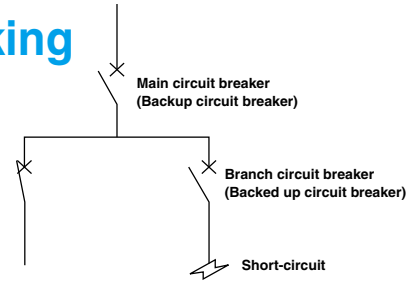

Table 4-23-1 440VAC (IEC 60947-2)

Main breaker Rated ultimate short-circuit breaking capacity of each breaker		NF-S • NV-S • NF-H • NV-H																				NF-C • NV-C				NF-R • NF-U											
		Branch breaker I <sub>cu</sub> (kA)																																			
NF32-SV	NF125-SV, NV125-SV	25	36	50	50	65	36	50	65	36	50	65	65	42	65	125	42	65	125	42	65	125	85	15	25	36	36	125	200	125	50	200	200				
	NV32-SV	5	14	14	14	14	14	5	5	5	5	5	5	5	5	7.5	7.5	7.5	7.5	7.5	7.5	7.5	7.5	5	-	-	-	35	125	35	50	-	-				
NF63-SV	NF125-SV, NV125-SV	7.5	14	14	14	20	20	15	15	15	15	15	15	15	15	15	15	15	15	15	15	15	10	10	10	10	50	125	50	50	10	10					
	NV63-SV	7.5	14	14	14	20	20	10	10	10	10	10	10	10	10	-	-	-	-	-	-	-	-	-	-	-	10	10	-	-	-	-	-				
NF63-HV	NF125-SV, NV125-SV	10	20	30	30	30	30	18	18	18	18	18	18	18	15	15	15	14	14	14	-	-	-	-	-	-	-	-	-	-	-	-	-				
	NV63-HV	10	20	30	30	30	30	18	18	18	18	18	18	18	15	15	15	14	14	14	-	-	-	-	-	-	-	-	-	-	-	-	-				
NF125-SV	NF125-SV, NV125-SV	25	-	36	36	50	50	36	36	50	-	36	50	42	50	35	35	35	35	35	35	30	35	35	30	-	-	-	-	125	200	125	200	50	35		
	NV125-SV	25	-	36	36	50	50	36	36	50	-	36	50	42	50	35	35	35	35	35	35	30	35	35	30	-	-	-	-	125	200	125	200	50	35		
NF125-SGV	NF125-SV, NV125-SV	36	-	50	-	50	-	50	50	-	50	-	50	-	50	-	50	50	-	50	50	-	50	50	-	-	-	-	-	-	-	-	-	-			
	NV125-SV	36	-	50	-	50	-	50	50	-	50	-	50	-	50	-	50	50	-	50	50	-	50	50	-	-	-	-	-	-	-	-	-	-	-		
NF125-LGV	NF125-SV, NV125-SV	50	-	-	-	-	-	-	-	-	-	-	-	-	-	-	-	-	-	-	-	-	-	-	-	-	-	-	-	-	-	-	-	-	-		
	NV125-SV	50	-	-	-	-	-	-	-	-	-	-	-	-	-	-	-	-	-	-	-	-	-	-	-	-	-	-	-	-	-	-	-	-	-	-	
NF125-HV	NF125-SV, NV125-SV	50	-	-	-	-	65	-	-	65	-	-	-	-	65	-	65	65	-	65	65	-	65	65	-	-	-	-	-	-	-	-	-	-	-		
	NV125-SV	50	-	-	-	-	65	-	-	65	-	-	-	-	65	-	65	65	-	65	65	-	65	65	-	-	-	-	-	-	-	-	-	-	-	-	
NF125-HGV	NF125-SV, NV125-SV	65	-	-	-	-	-	-	-	-	-	-	-	-	-	-	-	-	-	-	-	-	-	-	-	-	-	-	-	-	-	-	-	-	-	-	
	NV125-SV	65	-	-	-	-	-	-	-	-	-	-	-	-	-	-	-	-	-	-	-	-	-	-	-	-	-	-	-	-	-	-	-	-	-	-	-
NF160-SGV	NF125-SV, NV125-SV	36	-	-	-	-	-	-	-	-	-	-	-	-	-	50	50	-	50	50	-	50	50	50	-	-	-	-	-	-	-	-	-	-	-	-	
	NV125-SV	36	-	-	-	-	-	-	-	-	-	-	-	-	-	50	50	-	50	50	-	50	50	50	-	-	-	-	-	-	-	-	-	-	-	-	-
NF160-LGV	NF125-SV, NV125-SV	50	-	-	-	-	-	-	-	-	-	-	-	-	65	-	65	65	-	65	65	-	65	65	65	-	-	-	-	-	-	-	-	-	-	-	
	NV125-SV	50	-	-	-	-	-	-	-	-	-	-	-	-	-	-	-	-	-	-	-	-	-	-	-	-	-	-	-	-	-	-	-	-	-	-	-
NF160-HGV	NF125-SV, NV125-SV	65	-	-	-	-	-	-	-	-	-	-	-	-	-	-	-	-	-	-	-	-	-	-	-	-	-	-	-	-	-	-	-	-	-	-	-
	NV125-SV	65	-	-	-	-	-	-	-	-	-	-	-	-	-	-	-	-	-	-	-	-	-	-	-	-	-	-	-	-	-	-	-	-	-	-	-
NF250-SV	NF125-SV, NV125-SV	36	-	-	-	-	-	-	-	-	-	-	-	-	-	50	50	-	50	50	-	50	50	-	-	-	-	-	-	-	-	-	-	-	-	-	-
	NV250-SV	36	-	-	-	-	-	-	-	-	-	-	-	-	-	50	50	-	50	50	-	50	50	-	-	-	-	-	-	-	-	-	-	-	-	-	-
NF250-SGV	NF125-SV, NV125-SV	36	-	-	-	-	-	-	-	-	-	-	-	-	-	50	50	-	50	50	-	50	50	50	-	-	-	-	-	-	-	-	-	-	-	-	-
	NV250-SV	36	-	-	-	-	-	-	-	-	-	-	-	-	-	50	50	-	50	50	-	50	50	50	-	-	-	-	-	-	-	-	-	-	-	-	-
NF250-LGV	NF125-SV, NV125-SV	50	-	-	-	-	-	-	-	-	-	-	-	-	65	-	65	65	-	65	65	-	65	65	-	-	-	-	-	-	-	-	-	-	-	-	-
	NV250-SV	50	-	-	-	-	-	-	-	-	-	-	-	-	65	-	65	65	-	65	65	-	65	65	-	-	-	-	-	-	-	-	-	-	-	-	-
NF250-HV	NF125-SV, NV125-SV	65	-	-	-	-	-	-	-	-	-	-	-	-	-	-	-	-	-	-	-	-	-	-	-	-	-	-	-	-	-	-	-	-	-	-	-
	NV250-SV	65	-	-	-	-	-	-	-	-	-	-	-	-	-	-	-	-	-	-	-	-	-	-	-	-	-	-	-	-	-	-	-	-	-	-	-
NF250-HGV	NF125-SV, NV125-SV	65	-	-	-	-	-	-	-	-	-	-	-	-	-	-	-	-	-	-	-	-	-	-	-	-	-	-	-	-	-	-	-	-	-	-	-
	NV250-SV	65	-	-	-	-	-	-	-	-	-	-	-	-	-	-	-	-	-	-	-	-	-	-	-	-	-	-	-	-	-	-	-	-	-	-	-
NF400-SW	NF125-SV, NV125-SV	42	-	-	-	-	-	-	-	-	-	-	-	-	-	-	65	65	-	65	65	-	65	65	-	-	-	-	-	-	-	-	-	-	-	-	
	NV400-SW	42	-	-	-	-	-	-	-	-	-	-	-	-	-	-	65	65	-	65	65	-	65	65	-	-	-	-	-	-	-	-	-	-	-	-	-
NF630-SW	NF125-SV, NV125-SV	42	-	-	-	-	-	-	-	-	-	-	-	-	-	-	-	-	-	-	-	-	-	-	-	-	-	-	-	-	-	-	-	-	-	-	-
	NV630-SW	42	-	-	-	-	-	-	-	-	-	-	-	-	-	-	-	-	-	-	-	-	-	-	-	-	-	-	-	-	-	-	-	-	-	-	-
NF630-SEW	NF125-SV, NV125-SV	42	-	-	-	-	-	-	-	-	-	-	-	-	-	-	-	-	-	-	-	-	-	-	-	-	-	-	-	-	-	-	-	-	-	-	-
	NV630-SW	42	-	-	-	-	-	-	-	-	-	-	-	-	-	-	-	-	-	-	-	-	-	-	-	-	-	-	-	-	-	-	-	-	-	-	-
NF630-CV	NF125-SV, NV125-SV	2.5	10	14	14	14	14	5	5	5	5	5	5	5	5	-	-	-	-	-	-	-	-	-	5	-	-	-	35	125	35	50	5	-	-		
	NV630-CV	2.5	10	14	14	14	14	5	5	5	5	5	5	5	5	-	-	-	-	-	-	-	-	-	5	-	-	-	35	125	35	50	5	-	-	-	
NF125-CV	NF125-SV, NV125-SV	10	20	30	30	30	30	14	14	14	14	14	14	14	14	14	14	14	14	14	14	14	14	14	-	-	14	14	14	125	200	50	125	14	14		
	NV125-CV	10	20	30	30	30	30	14	14	14	14	14	14	14	14	14	14	14	14	14	14	14	14	14	-	-	14	14	14	125	200	50	125	14	14		
NF250-CV	NF125-SV, NV125-SV	15	-	-	-	-	-	-	-	-	-	-	-	-	-	30	30	30	-	-	-	-	-	-	-	-	-	-	-	-	-	-	-	-	-	-	
	NV250-CV	15	-	-	-	-	-	-	-	-	-	-	-	-	-	30	30	30	-	-	-	-	-	-	-	-	-	-	-	-	-	-	-	-	-	-	
NF400-CW	NF125-SV, NV125-SV	25	-	-	-	-	-	-	-	-	-	-	-	-	-	35	35	35	35	35	35	35	35	35	35	35	35	35	35	35	35	35	35	35	35	35	
	NV400-CW	25	-	-	-	-	-	-	-	-	-	-	-	-	-	35	35	35	35	35	35	35	35	35	35	35	35	35	35	35	35	35	35	35	35	35	
NF630-CW	NF125-SV, NV125-SV	36	-	-	-	-	-	-	-	-	-	-	-	-	-	-	-	-	-	-	-	-	-	-	-	-	-	-	-	-	-	-	-	-	-	-	
	NV630-CW	36	-	-	-	-	-	-	-	-	-	-	-	-	-	-	-	-	-	-	-	-	-	-	-	-	-	-	-	-	-	-	-	-	-	-	

Note Rated currents of main breakers are maximum values.

# 4 Selection 2 Selection of MCCB and ELCB

Table 4-23-2 230VAC (IEC 60947-2)

sym.kA

Main breaker Rated ultimate short-circuit breaking capacity of each breaker	NF-S • NV-S • NF-H • NV-H																				NF-C • NV-C				NF-R • NF-U														
	NF125-SV, NV125-SV	NF125-SGV	NF125-LGV	NF125-HV, NV125-HV	NF125-HGV	NF160-SGV	NF160-LGV	NF160-HGV	NF250-SV, NV250-SV	NF250-SGV	NF250-LGV	NF250-HV, NV250-HV	NF250-HGV	NF400-SV, NV400-SV	NF400-HV, NV400-HV	NF400-SW	NF400-REW	NF630-SV, NV630-SV	NF630-HV, NV630-HV	NF630-REW	NF800-SV, NV800-SV	NF800-HV, NV800-HV	NF800-REW	NF1000-SEW, NF1250-SEW, NF1600-SEW	NF250-CV, NV250-CV	NF400-CV, NV400-CV	NF630-CV, NV630-CV	NF800-CEW	NF125-RGV, NV125-RGV	NF125-UV	NF250-RGV	NF250-UV	NF400-UEW	NF800-UEW					
Branch breaker Icu(kA)	50	85	90	100	100	85	90	100	85	85	90	100	100	85	100	150	85	100	150	85	100	150	125	36	50	50	50	150	200	150	200	200	200	200					
NF32-SV	7.5	42	50	50	50	10	10	10	10	10	10	10	10	10	10	-	-	-	-	-	-	-	-	-	-	-	-	-	-	-	-	-	-	-	-	-	-		
NV32-SV	10	42	50	50	50	35	35	35	35	35	35	35	35	14	14	14	14	14	14	-	-	-	-	-	25	14	14	-	125	200	35	50	-	-	-	-			
NF63-SV	15	42	85	85	85	35	35	35	35	35	35	35	35	30	30	30	30	30	30	-	-	-	-	-	25	-	-	-	125	200	85	125	-	-	-	-	-		
NV63-SV	15	42	85	85	85	35	35	35	35	35	35	35	35	-	-	-	-	-	-	-	-	-	-	-	25	-	-	-	125	200	85	125	-	-	-	-	-		
NF63-HV	25	50	85	90	100	100	50	50	50	50	50	50	50	50	50	50	50	50	50	-	-	-	-	-	-	-	30	30	-	125	200	85	125	-	-	-	-		
NV63-HV	25	50	85	90	100	100	50	50	50	50	50	50	50	50	50	50	50	50	50	-	-	-	-	-	-	-	-	-	-	-	-	-	-	-	-	-	-		
NF125-SV	50	-	85	90	100	100	85	85	85	-	85	85	85	85	85	85	85	85	85	-	-	-	-	-	-	-	-	-	-	125	200	125	200	200	200	125	-		
NV125-SV	50	-	85	90	100	100	85	85	85	-	85	85	85	85	85	85	85	85	85	-	-	-	-	-	-	-	-	-	-	-	-	-	-	-	-	-	-		
NF125-SGV	85	-	-	-	100	-	-	-	-	-	-	-	-	-	-	-	-	-	-	-	-	-	-	-	-	-	-	-	-	-	-	-	-	-	-	-	-		
NF125-LGV	90	-	-	-	-	-	-	-	-	-	-	-	-	-	-	-	-	-	-	-	-	-	-	-	-	-	-	-	-	-	-	-	-	-	-	-	-		
NF125-HV	100	-	-	-	-	-	-	-	-	-	-	-	-	-	-	-	-	-	-	-	-	-	-	-	-	-	-	-	-	-	-	-	-	-	-	-	-		
NV125-HV	100	-	-	-	-	-	-	-	-	-	-	-	-	-	-	-	-	-	-	-	-	-	-	-	-	-	-	-	-	-	-	-	-	-	-	-	-		
NF125-HGV	100	-	-	-	-	-	-	-	-	-	-	-	-	-	-	-	-	-	-	-	-	-	-	-	-	-	-	-	-	-	-	-	-	-	-	-	-		
NF160-SGV	85	-	-	-	-	-	-	-	-	-	-	-	-	-	-	-	-	-	-	-	-	-	-	-	-	-	-	-	-	-	-	-	-	-	-	-	-		
NF160-LGV	90	-	-	-	-	-	-	-	-	-	-	-	-	-	-	-	-	-	-	-	-	-	-	-	-	-	-	-	-	-	-	-	-	-	-	-	-		
NF160-HGV	100	-	-	-	-	-	-	-	-	-	-	-	-	-	-	-	-	-	-	-	-	-	-	-	-	-	-	-	-	-	-	-	-	-	-	-	-		
NF250-SV	85	-	-	-	-	-	-	-	-	-	-	-	-	-	-	-	-	-	-	-	-	-	-	-	-	-	-	-	-	-	-	-	-	-	-	-	-		
NV250-SV	85	-	-	-	-	-	-	-	-	-	-	-	-	-	-	-	-	-	-	-	-	-	-	-	-	-	-	-	-	-	-	-	-	-	-	-	-		
NF250-SGV	85	-	-	-	-	-	-	-	-	-	-	-	-	-	-	-	-	-	-	-	-	-	-	-	-	-	-	-	-	-	-	-	-	-	-	-	-	-	
NF250-LGV	90	-	-	-	-	-	-	-	-	-	-	-	-	-	-	-	-	-	-	-	-	-	-	-	-	-	-	-	-	-	-	-	-	-	-	-	-	-	
NF250-HV	100	-	-	-	-	-	-	-	-	-	-	-	-	-	-	-	-	-	-	-	-	-	-	-	-	-	-	-	-	-	-	-	-	-	-	-	-	-	
NV250-HV	100	-	-	-	-	-	-	-	-	-	-	-	-	-	-	-	-	-	-	-	-	-	-	-	-	-	-	-	-	-	-	-	-	-	-	-	-	-	
NF250-HGV	100	-	-	-	-	-	-	-	-	-	-	-	-	-	-	-	-	-	-	-	-	-	-	-	-	-	-	-	-	-	-	-	-	-	-	-	-	-	
NF400-SV	85	-	-	-	-	-	-	-	-	-	-	-	-	-	-	-	-	-	-	-	-	-	-	-	-	-	-	-	-	-	-	-	-	-	-	-	-	-	
NV400-SV	85	-	-	-	-	-	-	-	-	-	-	-	-	-	-	-	-	-	-	-	-	-	-	-	-	-	-	-	-	-	-	-	-	-	-	-	-	-	
NF630-SV	85	-	-	-	-	-	-	-	-	-	-	-	-	-	-	-	-	-	-	-	-	-	-	-	-	-	-	-	-	-	-	-	-	-	-	-	-	-	
NV630-SV	85	-	-	-	-	-	-	-	-	-	-	-	-	-	-	-	-	-	-	-	-	-	-	-	-	-	-	-	-	-	-	-	-	-	-	-	-	-	
NF630-SEW	85	-	-	-	-	-	-	-	-	-	-	-	-	-	-	-	-	-	-	-	-	-	-	-	-	-	-	-	-	-	-	-	-	-	-	-	-	-	
NV630-SEW	85	-	-	-	-	-	-	-	-	-	-	-	-	-	-	-	-	-	-	-	-	-	-	-	-	-	-	-	-	-	-	-	-	-	-	-	-	-	
NF63-CV	7.5	35	50	50	50	10	10	10	10	10	10	10	10	-	-	-	-	-	-	-	-	-	-	-	-	-	-	-	-	-	-	-	-	-	-	-	-		
NV63-CV	7.5	35	50	50	50	10	10	10	10	10	10	10	10	-	-	-	-	-	-	-	-	-	-	-	-	-	-	-	-	-	-	-	-	-	-	-	-	-	
NF125-CV	30	35	85	85	85	50	50	50	50	50	50	50	50	50	50	50	50	50	50	-	-	-	-	-	-	-	-	-	-	-	-	-	-	-	-	-	-	-	
NV125-CV	30	35	85	85	85	50	50	50	50	50	50	50	50	50	50	50	50	50	50	-	-	-	-	-	-	-	-	-	-	-	-	-	-	-	-	-	-	-	
NF250-CV	36	-	-	-	-	-	-	-	50	50	50	50	50	50	50	50	50	50	50	50	-	-	-	-	-	-	-	-	-	-	-	-	-	-	-	-	-	-	-
NV250-CV	36	-	-	-	-	-	-	-	50	50	50	50	50	50	50	50	50	50	50	50	-	-	-	-	-	-	-	-	-	-	-	-	-	-	-	-	-	-	-
NF400-CW	50	-	-	-	-	-	-	-	-	-	-	-	-	85	85	85	85	85	85	85	85	85	85	85	85	-	-	-	-	-	-	-	-	-	-	-	-	-	
NV400-CW	50	-	-	-	-	-	-	-	-	-	-	-	-	85	85	85	85	85	85	85	85	85	85	85	85	-	-	-	-	-	-	-	-	-	-	-	-	-	
NF630-CW	50	-	-	-	-	-	-	-	-	-	-	-	-	-	-	-	-	-	-	-	-	-	-	-	-	-	-	-	-	-	-	-	-	-	-	-	-	-	
NV630-CW	50	-	-	-	-	-	-	-	-	-	-	-	-	-	-	-	-	-	-	-	-	-	-	-	-	-	-	-	-	-	-	-	-	-	-	-	-	-	

Note Rated currents of main breakers are maximum values.

## 12. International Standard Conformance List

### 12.1 UL and CSA Approval Product

#### ●UL (Underwriter’s Laboratories) Standards: UL 489, UL 1077

UL is an organization in the US which establishes safety standards, i.e. UL Standards, conducts safety verification test based on the UL Standards, issues the certificates to approved products and allows the manufacturers to attach the certification mark to the products. The UL certification mark has been spread widely in the US. Some states and cities oblige manufacturers to receive the UL certification. When devices, control panels and machines are exported to the US, these products must be UL certified. UL certified products have received UL Recognition or UL Listing in conformity to UL Standards (UL 489, UL1077) and allowed to be used in control panels and machines to be exported to the US.



#### **UL Recognition**

Refers to component certification for products designed to be built in other products and devices. UL recognized products can be used in control panels, machine tools and control units.



#### **UL Listing**

Refers to product certification for products which can be sold directly to end-users and used by end-users. These products can be used also as built-in components in control panels, machine tools and control units. Some models vary in external dimensions and terminal structure from standard models. Please refer to the page of UL listed products for details.

#### ●CSA (Canadian Standard Association) Standards: CSA C22.2 No.5

The CSA Standards are product safety standards established by CSA. In Canada, the safety of electric products is regulated by the state laws, and some state laws prescribe that circuit breakers shall be certified by the CSA Standards. Therefore, when devices, control panels and machines are exported to Canada, these products must be CSA certified. UL certified products have received CSA certification from the testing body UL and allowed to be used in control panels and machines to be exported to Canada. UL has been authorized as a testing, certification and quality certification body by SCC, and CSA certified products tested by UL have been approved by the safety regulations in all states of Canada. It is allowed to attach the following certification marks to products certified by both UL and CSA. (It is also allowed to attach the separate marks for the US and Canada as before.)



#### **Recognition for US and Canada**

UL and CSA recognition of components by testing body UL



#### **Listing for US and Canada**

UL and CSA recognition of components by testing body UL

### 12.2 CCC (China Compulsory Certification) Approval Product

Low-voltage circuit breakers are designated as products to be compulsorily certified in China. To export such products to China and sell them in China, it is necessary to obtain the CCC certification.



### 12.3 Corresponding to CE Marking and UKCA Marking

#### ●Corresponding to low voltage directives (CE marking) and to low voltage regulations (UKCA marking)

##### (1)When using a low voltage circuit breaker as a component and indicating conformity with the EC Directives

The CE Marking is required when a low voltage circuit breaker is distributed as a single device in EU. However, when the CE Mark is indicated on a machine tool or a control unit, it is unnecessary to affix the CE Mark to the low-voltage circuit breaker used as a built-in component. When the CE

Mark is indicated on a machine tool or a control unit, it is recommended to use a product certified by a third party shown in Item (3) (TÜV certified product) as a low voltage circuit breaker.

##### (2)Measures for export of low voltage circuit breaker as single unit

When exporting a low-voltage circuit breaker as a single unit in EU, the circuit breaker is covered by the Low Voltage Directive. The certification of conformity with the Low Voltage Directive is self-declared as a rule. The applicable product standards are shown below.

EN 60947-2 Low-voltage switchgear and controlgear-Part 2: Circuit-breakers

EN 60934 Circuit-breakers for equipment (CBE)

##### (3)Models certified by third party (TÜV certified products)

When the CE Mark is indicated on a machine tool or a control unit, it is recommended to use a low voltage circuit breaker certified by a third party (TÜV certified product) as a built-in component.



#### ●Corresponding to RoHS directives (CE marking) and to the regulations regarding RoHS hazardous items (UKCA marking)

The Directive prescribes that products shall not emit high-intensity radio waves to the outside and shall not be affected by external electromagnetic waves. Molded case circuit breakers (electronic type) and earth leakage circuit breakers are covered by the EMC Directive. These products have been designed for environment A. Use of these products in environment B may cause unwanted electro magnetic disturbances in which case the user may be required to take adequate mitigation measures.

#### ●Corresponding to EMC directives (CE marking) and to EMC regulations (UKCA marking)

Low voltage circuit breakers are components used in equipment, such as machine tools and control units, and are not covered by any machinery directive. When the CE Mark is indicated on a machine tool or a control unit, it is recommended to use a low voltage circuit breaker certified by a third party (TÜV certified product) as a built-in component.

#### ●Corresponding to Machinery directives (CE marking) and to Machinery regulations (UKCA marking)

Low voltage circuit breakers are components that are used for manufacturing machines or control equipment, and machinery directive is not applicable.

# 4 Selection 2 Selection of MCCB and ELCB

## ●Molded Case Circuit Breakers and Motor Protection Breakers

Specifications	Class	Applicable Models and Assignments	North American Safety Mark					Compulsory Mark			Third Party Mark	Classification Society (*1)
			UL Standards			CSA Standards		CCC	CE	UKCA	TÜV Rheinland	NK
			USA			Canada		China	Europe	United Kingdom	Germany	Japan
General	C	NF63-CV, NF125-CV	-	-	-	-	-	●	●(Self-declaration)	●(Self-declaration)	-	●
		NF250-CV	-	-	-	-	-	●	●	●(Self-declaration)	-	●
		NF400-CW, NF630-CW, NF800-CEW	-	-	-	-	-	●	●(Self-declaration)	●(Self-declaration)	-	●
	S	NF32-SV, NF63-SV, NF125-SV	-	-	-	-	-	●	●(Self-declaration)	●(Self-declaration)	-	●
		NF125-SEV	-	-	-	-	-	●	●(Self-declaration)	●(Self-declaration)	-	-
		NF250-SV	-	-	-	-	-	●	●	●(Self-declaration)	(Except for 4P)	●
		NF125-SGV, NF160-SGV, NF250-SGV, NF250-SEV	-	-	-	-	-	●	●(Self-declaration)	●(Self-declaration)	-	-
		NF400-SW, NF630-SW	-	-	-	-	-	●	●(Self-declaration)	●(Self-declaration)	-	●
		NF400-SEW, NF630-SEW	-	-	-	-	-	●	●(Self-declaration)	●(Self-declaration)	-	●
		NF800-SEW, NF800-SDW	-	-	-	-	-	●	●(Self-declaration)	●(Self-declaration)	-	●
	L/H/R	NF1000-SEW, NF1250-SEW	-	-	-	-	-	●	●(Self-declaration)	●(Self-declaration)	-	●
		NF1600-SEW	-	-	-	-	-	●	●(Self-declaration)	●(Self-declaration)	-	-
		NF1250-SDW, NF1600-SDW	-	-	-	-	-	●	●(Self-declaration)	●(Self-declaration)	-	-
		NF63-HV	-	-	-	-	-	●	●(Self-declaration)	●(Self-declaration)	-	●
		NF125-HV	-	-	-	-	-	●	●(Self-declaration)	●(Self-declaration)	-	●
		NF125-HEV	-	-	-	-	-	●	●(Self-declaration)	●(Self-declaration)	-	-
		NF250-HV	-	-	-	-	-	●	●(Self-declaration)	●(Self-declaration)	-	●
	U	NF125-LGV, NF125-HGV, NF160-LGV, NF250-LGV, NF250-HGV, NF250-HEV, NF125-RGV, NF250-RGV	-	-	-	-	-	●	●(Self-declaration)	●(Self-declaration)	-	-
		NF400-HEW, NF400-REW	-	-	-	-	-	●	●(Self-declaration)	●(Self-declaration)	-	●
		NF630-HEW, NF630-REW	-	-	-	-	-	●	●(Self-declaration)	●(Self-declaration)	-	●
		NF800-HEW, NF800-REW	-	-	-	-	-	●	●(Self-declaration)	●(Self-declaration)	-	●
		NF125-UV	-	-	-	-	-	-	●(Self-declaration)	●(Self-declaration)	-	●
		NF250-UV, NF400-UEW	-	-	-	-	-	-	●(Self-declaration)	●(Self-declaration)	-	●
		NF800-UEW	-	-	-	-	-	-	●(Self-declaration)	●(Self-declaration)	-	-
Motor Protection	NF32-SV MB, NF63-CV MB, NF63-SV MB, NF125-SV MB	-	-	-	-	-	●	●(Self-declaration)	●(Self-declaration)	-	●	
	NF250-SV MB	-	-	-	-	-	●	●	●(Self-declaration)	●	●	
HDV	NF63-HDV(2P)	-	-	-	-	-	-	●(Self-declaration)	●(Self-declaration)	-	-	
	NF63-HDV(3P)	-	-	-	-	-	-	●(Self-declaration)	●(Self-declaration)	-	-	
HDVA	NF125-HDVA	-	-	-	-	-	(*1)	●(Self-declaration) (Except for 3P)	●(Self-declaration)	-	-	
	NF250-HDVA	-	-	-	-	-	(*1)	●(Self-declaration) (Except for 3P)	●(Self-declaration)	-	-	
HDW	NF400-HDW	-	-	-	-	-	●	●(Self-declaration)	●(Self-declaration)	-	-	
	NF800-HDW	-	-	-	-	-	●	●(Self-declaration)	●(Self-declaration)	-	-	
UL	UL 489 Listed	NF50-SMU	-	-	-	●	-	●	●(Self-declaration)	●(Self-declaration)	●	-
		NF50-SVFU, NF100-CVFU	-	-	-	●	-	●	●(Self-declaration)	●(Self-declaration)	●	-
		NF100-SRU	-	-	-	●	-	●	●(Self-declaration)	●(Self-declaration)	●	-
		NF100-HRU	-	-	-	●	-	●	●(Self-declaration)	●(Self-declaration)	●	-
		NF125-SVU, NF125-HVU	-	-	-	●	-	●	●(Self-declaration)	●(Self-declaration)	●	-
		NF250-CVU	-	-	-	●	-	●	●(Self-declaration)	●(Self-declaration)	●	-
		NF250-SVU, NF250-HVU	-	-	-	●	-	●	●(Self-declaration)	●(Self-declaration)	●	-
		NF400-SWU, NF400-HWU	-	-	-	●	-	●	●(Self-declaration)	●(Self-declaration)	●	-
		NF630-SWU, NF630-HWU	-	-	-	●	-	●	●(Self-declaration)	●(Self-declaration)	●	-

Note \*1 Except for 4 poles breaker.  
Remark: 1. KC (Korea Certification) and EAC (Eurasian Conformity) approval products are prepared. Please inquire details.

## ●Earth Leakage Circuit Breakers

Specifications	Class	Applicable Models and Assignments	North American Safety Mark					Compulsory Mark			Third Party Mark	Classification Society
			UL Standards			CSA Standards		CCC	CE	UKCA	TÜV Rheinland	NK
			USA			Canada		China	Europe	United Kingdom	Germany	Japan
General	C	NV63-CV, NV125-CV	-	-	-	-	-	●	●(Self-declaration)	●(Self-declaration)	-	-
		NV250-CV	-	-	-	-	-	●	●	●(Self-declaration)	●	-
		NV400-CW, NV630-CW	-	-	-	-	-	●	●(Self-declaration)	●(Self-declaration)	-	-
	S	NV32-SV, NV63-SV	-	-	-	-	-	●	●(Self-declaration)	●(Self-declaration)	-	-
		NV125-SV	-	-	-	-	-	●	●(Self-declaration)	●(Self-declaration)	-	-
		NV250-SV	-	-	-	-	-	●	●	●(Self-declaration)	●	-
		NV125-SEV, NV250-SEV, NV400-SW, NV400-SEW, NV630-SW, NV630-SEW, NV800-SEW	-	-	-	-	-	●	●(Self-declaration)	●(Self-declaration)	-	-
		NV63-HV	-	-	-	-	-	●	●(Self-declaration)	●(Self-declaration)	-	-
		NV125-HV	-	-	-	-	-	●	●(Self-declaration)	●(Self-declaration)	-	-
		NV125-HEV, NV250-HV, NV250-HEV	-	-	-	-	-	●	●(Self-declaration)	●(Self-declaration)	-	-
NV400-HEW, NV630-HEW, NV800-HEW	-	-	-	-	-	●	●(Self-declaration)	●(Self-declaration)	-	-		
UL	UL 489 Listed	NV50-SVFU, NV100-CVFU	-	-	-	●	-	●	●(Self-declaration)	●(Self-declaration)	●	-
		NV125-SVU, NV125-HVU	-	-	-	●	-	●	●(Self-declaration)	●(Self-declaration)	●	-
		NV250-CVU	-	-	-	●	-	●	●(Self-declaration)	●(Self-declaration)	●	-
		NV250-SVU, NV250-HVU	-	-	-	●	-	●	●(Self-declaration)	●(Self-declaration)	●	-

Remark: 1. KC (Korea Certification) and EAC (Eurasian Conformity) approval products are prepared. Please inquire details.

## ●Miniature Circuit Breakers

Specifications	Class	Applicable Models	Compulsory Mark		
			CCC	CE	UKCA
			China	Europe	United Kingdom
General	DIN	BH-D6	●	●(Self-declaration)	●(Self-declaration)
		BH-D10	●	●(Self-declaration)	●(Self-declaration)
		BH-DN	●	●(Self-declaration)	●(Self-declaration)
		BV-D	●	●(Self-declaration)	●(Self-declaration)
		BV-DN	●	●(Self-declaration)	●(Self-declaration)
		KB-D	●	●(Self-declaration)	●(Self-declaration)

●Circuit Protectors

The certification marked with ● is displayed on the surface of the circuit breaker.  
The certification marked with △ is recognized.

Specifications	Class	Applicable Models and Assignments	North American Safety Mark					Compulsory Mark			Third Party Mark	Classification Society
			UL Standards		CSA Standards			CCC	CE	UKCA	TÜV Rheinland	NK
			USA		Canada			China	Europe	United Kingdom	Germany	
												Japan
General	CP	CP30-BA, CP30-HU	-	-	●	-	-	●(GB/T 17701) (*1)(*3)(*4)	●(EN 60934)(*3)(*4) ●(EN 60947-2) (Self-declaration) ●(EN 60947-3)(*2)	●(EN 60934:Self-declaration)(*3)(*4) ●(EN 60947-2:Self-declaration) ●(EN 60947-3:Self-declaration)(*2)	△ (EN 60934) (*3)(*4) △ (EN 60947-3) (*2)	-

Remark: 1. KC (Korea Certification) approval products are prepared. Please inquire details. (Excluding CP30-HU)

Notes \*1 Only CP30-BA is applicable. (CCC is not applicable for those with SHT)

\*2 Only applicable to 1P SHT.

\*3 Spring clamp terminals with a rated current of 20A are not applicable.

\*4 Not applicable to male tab terminals.

●Air Circuit Breakers

Specifications	Class	Applicable Models	Assignments	North American Safety Mark					Compulsory Mark			Third Party Mark
				UL Standards		CSA Standards			CCC	CE	UKCA	TÜV Rheinland
				USA		Canada			China	Europe	United Kingdom	Germany
IEC	SW	AE630-SW, AE1000-SW AE1250-SW, AE1600-SW AE2000-SWA, AE2000-SW AE2500-SW, AE3200-SW AE4000-SWA, AE4000-SW AE5000-SW, AE6300-SW	IEC 60947-2 or JIS C 8201-2-1	-	-	-	-	-	-	●(Self-declaration)	●(Self-declaration)	-
CCC	SW	AE630-SW, AE1000-SW AE1250-SW, AE1600-SW AE2000-SWA, AE2000-SW AE2500-SW, AE3200-SW AE4000-SWA, AE4000-SW AE5000-SW, AE6300-SW	CCC	-	-	-	-	-	●	●(Self-declaration)	●(Self-declaration)	-

Remark: 1. EAC (Eurasian Conformity) approval products are prepared. Please inquire details.

●Molded Case Circuit Breakers , Motor Protection Breakers, Air Circuit Breakers, Circuit Protectors and Miniature Circuit Breakers (Classification Society)

Specifications	Class	Applicable Models	Classification societies (Note)					
			NK	LR	ABS	BV	CCS	DNV
			Japan	United Kingdom	USA	France	China	Norway
General	C	NF63-CV, NF125-CV	●	●	●	●	●	●
		NF250-CV	●	●	●	●	●	●
		NF400-CW, NF630-CW	●	●	●	●	-	-
		NF800-CEW	●	●	●	●	-	●
		NF32-SV, NF63-SV, NF125-SV	●	●	●	●	●	●
	S	NF250-SV	●	●	●	●	●	-
		NF400-SW, NF630-SW	●	●	●	●	●	-
		NF400-SEW, NF630-SEW	●	●	●	●	●	●
		NF800-SEW	●	●	●	●	-	●
		NF1000-SEW, NF1250-SEW	●	●	●	-	-	-
	H/R	NF63-HV, NF125-HV	●	●	●	●	●	●
		NF250-HV	●	●	●	●	●	●
		NF400-HEW, NF400-REW	●	●	●	●	(HEW)	-
		NF630-HEW, NF630-REW NF800-HEW, NF800-REW	-	-	-	-	-	-
	U	NF125-UV, NF250-UV	●	●	●	●	●	●
		NF400-UEW, NF800-UEW	●	●	●	●	-	-
	Motor Protection	NF32-SV MB, NF63-CV MB	●	●	●	●	●	●
NF63-SV MB, NF125-SV MB		●	●	●	●	●	●	
NF250-SV MB		●	●	●	●	●	●	
AE	AE630-SW, AE1000-SW AE1250-SW, AE1600-SW AE2000-SWA, AE2000-SW AE2500-SW, AE3200-SW AE4000-SWA	●	●	●	●	●	●	
	AE4000-SW, AE5000-SW, AE6300-SW	●	●	●	●	-	●	
	CP30-BA	● (*2)(*3)	-	-	-	-	-	
BH	BH-D6, BH-D10	-	-	-	-	●	●	
KB	KB-D	-	-	-	-	●	●	

Remark: 1. 4 poles breakers does not acquire Classification Society approval.

Note \*1 Except for 4 poles breaker.

\*2 Some specifications are not supported depending on the number of poles and operating characteristics. Please introduce the details.

\*3 Male tab terminals and spring clamp terminals are excluded.

## 1. Electric Shock Protection

The safety standards for current passing through the human body are determined based on physiological phenomena as shown below.

- In places where secondary accidents may be caused by electric shock: Area below the curve b
- In places where secondary accidents will not be caused by electric shock: Area below the curve c1

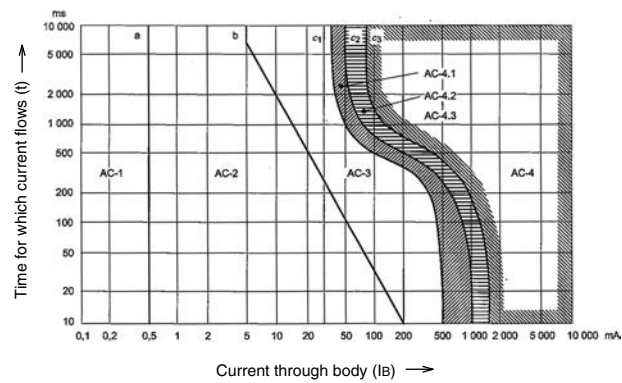

**Fig. 4.17 Influence of AC (15Hz to 100Hz) on human body (IEC/TS60479-1)**

## 2. ELCB Grounding Method

Select the rated sensitivity current based on the grounding method, purpose of protection and protection ground resistance value of load device. If the line is excessively long, the circuit breaker may operate unnecessarily owing to leakage current. Calculate the leakage current referring to Table 4-25. In this case, it is common to select sensitivity current approx. 10 times as high as the leakage current.

Table 4-24

Type of earthing system	TN system			TT system	IT system	
	TN-C system	TN-S system	TN-C-S system			
Typical arrangement						
Protective condition	The touch voltage is limited to 50V.					
	$Z_s \times I_a \leq 50V$ Zs: fault loop impedance (Ω) Ia: current causing the automatic operation of the disconnecting device within the time as below (A) U <sub>0</sub> : nominal line to earth voltage (V)			$R_A \times I_{\Delta n} \leq 50V$ R <sub>A</sub> : sum of the resistances of the earth electrode and the protective conductor (Ω) I <sub>Δn</sub> : rated current sensitivity (A)		$I_d \times R_A \leq 50V$ R <sub>A</sub> : sum of the resistances of the earth electrode and the protective conductor (Ω) I <sub>d</sub> : first fault current (A)
Earth leakage protective device	Maximum disconnection times (s)					
	U <sub>0</sub> AC	Branch circuits rated 32A and less				Others
		120V	230V	400V	Over 400V	
TN system	0.8	0.4	0.2	0.1	5	
TT system	0.3	0.2	0.07	0.04	1	
Earth leakage protective device	- MCCBs Not ELCBs	- MCCBs - ELCBs	- MCCBs - ELCBs (except in TN-C zone)		- ELCBs	- Insulation monitoring devices + ELCBs

Table 4-25 Leakage current when 600V vinyl insulated wire is laid on 1km Δ-connected 3-phase 3-wire 200V line

Distance from grounded part	① 4m or more	② 10cm or more	③ 1.5mm or more	④ In close contact
	Wiring work	<ul style="list-style-type: none"> <li>Wiring on first floor ceiling of wooden building</li> <li>Wiring on second and higher floors of wooden building</li> <li>Aerial wiring</li> </ul> (Except ③ and ④)	<ul style="list-style-type: none"> <li>Wiring in RC building</li> <li>Wiring with vinyl tube and exposed wiring in steel frames</li> </ul> (Except ③ and ④)	<ul style="list-style-type: none"> <li>Vinyl tube burying</li> <li>Vinyl tube laying in close contact with steel frames in steel building</li> </ul>
Wire size	8mm <sup>2</sup> or less	14	22	38
	0.60mA/km	0.66	0.72	0.81
		1.29mA/km	1.44	1.55
			1.75	1.99
			2.14	2.46
			2.72	3.16
			3.29	3.69
			50.7	56.8
			253	284

Notes \*1 The leakage current on rubber insulated wire (RB) is about 70% of the above values, and that on 3-core 600V cross-linked polyethylene insulated wire (CV) is about 50%.

\*2 At 50Hz, the values are 84% of the above values.

\*3 To obtain the leakage current on another line, multiply the values shown in Table 4-25 by the magnification shown in Table 4-26.

\*4 To determine the line length, add the length of all wires after ELCB installation point.

Table 4-26 Leakage current conversion table

Type of line	Magnification
Single-phase 100V line	0.3
Single-phase 3-wire 200V line	0.3
3-phase 415V line (Δ connection)	0.7

## 3. Rated Voltage and Number of Poles

Select the rated voltage and number of poles according to the circuit voltage and type. The following table shows the standard circuit voltage values. However, even at special voltage, if the voltage including the circuit voltage fluctuation is within the voltage range shown right, the leakage protection device will operate.

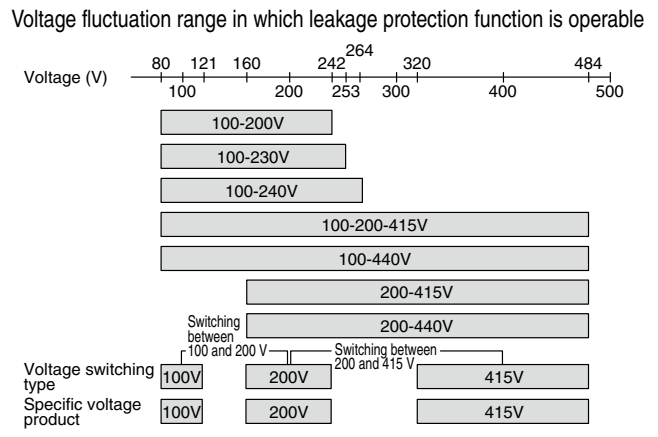

Table 4-27

Circuit type	Single-phase 2-wire 100 or 200V circuit	Single-phase 3-wire 100 and 200V circuit
Example of connection	<ul style="list-style-type: none"> <li>• 100-440V</li> <li>• 100-200-415V</li> <li>• 100-200V</li> <li>• 100-240V</li> <li>• 100-440V</li> <li>• 100-200-415V</li> <li>• 100-200V</li> <li>• 100-230V</li> <li>• 100V</li> <li>• 100-440V</li> <li>• 100-200-415V</li> <li>• 100-200V</li> <li>• 100-230V</li> <li>• 200-415V</li> <li>• 200-440V</li> </ul>	<ul style="list-style-type: none"> <li>• 100-200-415V</li> <li>• 100-200V</li> <li>• 200-415V</li> <li>• 100-230V</li> <li>• 100-440V</li> <li>• 200-440V</li> <li>• 100-200-415V</li> <li>• 100-200V</li> <li>• 100V</li> <li>• 100-240V</li> <li>• 100-230V</li> <li>• 100-440V</li> <li>• 100-200-415V</li> <li>• 100-200V</li> <li>• 100-240V</li> <li>• 100-230V</li> <li>• 100-440V</li> <li>• 200-440V</li> </ul>
Circuit type	3-phase 3-wire 200V circuit	3-phase 3-wire 415V circuit
Example of connection	<ul style="list-style-type: none"> <li>• 100-200-415V</li> <li>• 100-200V</li> <li>• 200-415V</li> <li>• 100-440V</li> <li>• 100-230V</li> <li>• 200-440V</li> <li>• 100-200-415V</li> <li>• 200-415V</li> <li>• 100-440V</li> <li>• 200-440V</li> </ul>	<ul style="list-style-type: none"> <li>• 100-200-415V</li> <li>• 200-415V</li> <li>• 415V</li> <li>• 100-440V</li> <li>• 200-440V</li> <li>• 100-200-415V</li> <li>• 200-415V</li> <li>• 415V</li> <li>• 200-440V</li> </ul>
Circuit type	3-phase 4-wire 415V circuit	
Example of connection	<ul style="list-style-type: none"> <li>• 100-200-415V</li> <li>• 200-415V</li> <li>• 100-440V</li> <li>• 200-440V</li> <li>• 100-200-415V</li> <li>• 200-415V</li> <li>• 415V</li> <li>• 100-440V</li> <li>• 200-440V</li> <li>• 100-200-415V</li> <li>• 200-415V</li> <li>• 415V</li> <li>• 100-240V</li> <li>• 100-440V</li> <li>• 200-440V</li> <li>• 100-200-415V</li> <li>• 200-415V</li> <li>• 415V</li> <li>• 200-440V</li> </ul>	

<Cautions when selecting and connecting>

(1) When a 3-pole circuit breaker is used as a 2-pole one, use the right and left poles.

(2) For the mains of a 3-phase 4-wire 415V circuit, use a 4-pole circuit breaker having a rated voltage of 415V or 440V, and connect the neutral pole to the N pole on the right side.

## 4. Earth Fault Protection Coordination and Combination of Devices

Table 4-28

Protection type	Details	Installation point	Combination
With selectivity only for earth fault breaking	● On general lines, the protection grounding resistance is relatively large and the earth fault current is small. In this case, install a time-delay relay on the main circuit and a high-speed relay on a branch circuit.	Main circuit	• Time-delay ELCB • Combination of MCCB and time-delay earth leakage relay
		Branch circuit	High-speed ELCB
With selectivity for earth fault breaking and cascade type of short-circuit breaking	● The selectivity for earth fault breaking is as stated above. ● Significant short-circuit fault very rarely occurs because of its nature (in most cases, circuits are broken at the early stage of earth fault). This protection is applied when the continuity of power supply is expendable. (Refer to the combination for cascade breaking on page 83.)	Main circuit	• Class S time-delay ELCB • Combination of MCCB (class U) and time-delay earth leakage relay
		Branch circuit	• Class C time-delay ELCB • Combination of MCCB (class C) and high-speed earth leakage relay
With selectivity for earth fault breaking and short-circuit breaking	● This protection is applied when selectivity is necessary in the entire area of fault. (Refer to the combination for selective breaking on page 81.)	Main circuit	Combination of electronic MCCB and time-delay earth leakage relay
		Branch circuit	• High-speed ELCB • Combination of MCCB and high-speed earth leakage relay

Remark: 1. "Time-delay or high-speed earth leakage relay" refers to NV-ZBA, NV-ZSA, NV-ZHA or NV-ZLA.

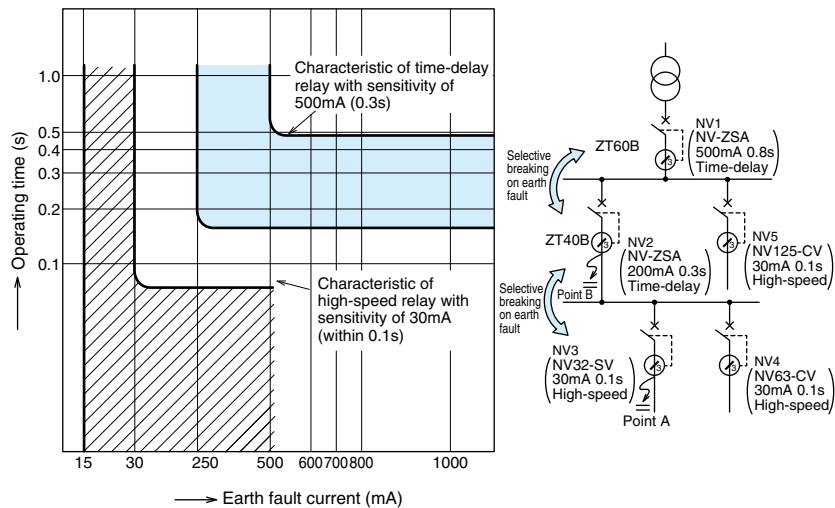

Fig. 4.18 Example of coordination of time-delay and high-speed relays for earth fault breaking









# 5

## Installation and Connection

1) Connection Types.....	98
2) Connecting Parts .....	100
3) Standard Tightening Torque .....	101
4) Crimp Terminal Type .....	102
5) Busbar .....	104
6) Insulation Distance on Power Source Side .....	105
7) Effect of Installation Orientation .....	106
8) Connection of Line and Load .....	106

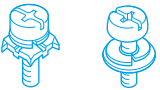
## 1. Connection Types

Table 5-1 Connection

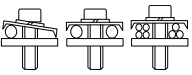
Connection type (Code address)		Front connection (F)					
		Screw terminal (AMP-N)	Busbar terminal (BAR)	Solderless (BOX) terminal (SL)			
Image							
MCCB	C	NF32-SV • NF63-CV • NF63-SV • NF63-HV	●	● (*2)	-		
	S	NF125-CV • NF125-SV • NF125-HV	●	● (*2)	●		
	H	NF125-SEV • NF125-SGV • NF125-LGV • NF125-HEV • NF125-HGV	●	● (*2)	●		
	MB		NF160-SGV • NF160-LGV • NF160-HGV • NF250-CV • NF250-SV • NF250-HV • NF250-SEV • NF250-HEV • NF250-SGV • NF250-LGV • NF250-HGV	●	● (*2)	●	
			NF400-SW • NF400-SEW • NF400-HEW • NF400-CW	-	●	-	
	R		NF630-SW • NF630-SEW • NF630-HEW • NF630-CW	-	●	-	
			NF800-SEW • NF800-HEW • NF800-SDW • NF800-CEW	-	●	-	
			NF1000-SEW • NF1250-SEW • NF1600-SEW	-	●	-	
			NF125-UV	●	● (*2)	●	
	U		NF125-RGV • NF250-RGV • NF250-UV	●	●	●	
			NF400-UEW • NF400-REW	-	●	-	
			NF630-REW	-	●	-	
	FAFAU		NF30-FAU • NF50-FAU	●	-	-	
	FHU		NF50-FHU • NF100-FHU	●	-	-	
	UL		NF50-SVFU	●	●	-	
			NF100-CVFU	●	●	●	
			NF125-SVU	●	●	●	
			NF125-HVU	●	●	●	
			NF250-CVU • NF250-SVU • NF250-HVU	●	●	●	
			NF100-SRU • NF100-HRU	●	●	●	
ELCB	C	NV32-SV • NV63-CV • NV63-SV • NV63-HV	●	● (*2)	-		
	S	NV125-CV • NV125-SV • NV125-HV	●	● (*2)	-		
	H	NV125-SEV • NV125-HEV	●	● (*2)	-		
		NV250-CV/SV/HV • NV250-SEV/HEV	●	● (*2)	-		
		NV400-SW • NV400-SEW • NV400-HEW • NV400-CW	-	●	-		
		NV630-SW • NV630-SEW • NV630-HEW • NV630-CW	-	●	-		
		NV800-SEW • NV800-HEW	-	●	-		
	FAFAU		NV30-FAU • NV50-FAU	●	-	-	
	FHU		NV50-FHU • NV100-FHU	●	-	-	
	UL		NV100-SRU • NV100-HRU	●	●	●	
Kind of terminal screw (A)							
(Circuit breakers having frame size of 1000A and more are not provided with terminal screws (A).)							
Shape							
	Pan-head screw with clamp		Pan-head screw	Bolt (Hex-socket)	Bolt		
Screw size	M5		M8	M8	2xM8		
Remarks		NF32-SV 63-CV 63-SV 63-HV 50-SVFU(*1) NF30-FAU 50-FAU 50-FHU	NF 63-CV(60, 63A) 63-SV(60, 63A) 63-HV(60, 63A) 125-CV 125-SV 125-HV 100-CVFU 125-SVU 125-HVU 125-UV 100-FHU	NV 63-CV(60, 63A) 63-SV(60, 63A) 63-HV(60, 63A) 125-CV 125-SV 125-HV 100-FHU	NF 125-SEV 125-HEV 125-RGV 125-SGV 125-LGV 125-HGV 160-SGV 160-LGV 160-HGV 250-CV 250-SV 250-HV 250-SEV 250-HEV 250-CVU 250-SVU 250-HVU	NF 400-UEW(4P) 800-CEW 800-SEW 800-HEW 800-REW 800-UEW 800-SDW 800-HEW	NF 400-CW 400-SW 400-SEW 400-HEW 400-REW 400-UEW(3P) 630-CW 630-SW 630-SEW 630-HEW 630-REW
	Type	In case of clamp connection (*1) 					
	①When the wire size is 5.5mm <sup>2</sup> or more, divide the wires, and connect them. ②When connecting wires differing in size, for example, φ1.6 wires and 5.5mm <sup>2</sup> wires, connect the two kinds of wires together to a crimp terminal because the thinner wires easily come off. ③Do not tighten directly solid wires and cords consisting of thin copper wires used as strands, for example φ1.6 and 1.25mm <sup>2</sup> wires, together.						

Note \*1 It is impossible to directly connect the wires of 40 and 50A, NF/NV 50-SVFU.  
\*2 It is possible to modify connection type with options.



## 2. Connecting Parts

For the connection shown in the table on the previous page, the following parts are available as connecting parts.

**Table 5-3 Studs on rear surface (B-ST)**

Type name	Number of poles	Applicable models		Stud shape and major included parts	Remarks
		MCCB	ELCB		
ST-05SV2	2	NF32-SV, NF63-CV, NF63-SV NF63-HV	NV32-SV, NV63-CV NV63-SV, NV63-HV	★Round studs ●Round studs (with insulating tube) (2-pole: 4 pcs, 3-pole: 6 pcs, 4-pole: 8 pcs) ●Bolts and nuts	One set includes the parts for one unit. Please place an order for the number of circuit breakers.
ST-05SV3	3				
ST-05SV4	4	NF63-SV, NF63-HV	—	★Bar studs ●Bar studs (with insulating tube) (2-pole: 4 pcs, 3-pole: 6 pcs, 4-pole: 8 pcs) ●Bolts and nuts	
ST-1SV2	2	NF125-CV, NF125-SV NF125-HV(3, 4P)	—		
ST-1SV3	3		NV125-CV, NV125-SV NV125-HV	★Bar studs ●Bar studs (with insulating tube) (2-pole: 4 pcs, 3-pole: 6 pcs, 4-pole: 8 pcs) ●Bolts and nuts	
ST-1SV4	4				
ST-1HV2	2		NF125-HV(2P)	—	
ST-2SV2	2	NF125-SEV, NF125-HEV, NF125-RGV NF125-SGV, NF125-LGV, NF125-HGV NF160-SGV, NF160-LGV, NF160-HGV NF250-SGV, NF250-LGV, NF250-HGV	—	★Bar studs ●Bar studs (with insulating tube) (2-pole: 4 pcs, 3-pole: 6 pcs, 4-pole: 8 pcs) ●Bolts and nuts	
ST-2SV3	3		NV125-SEV, NV125HEV NV250-CV, NV250-SV NV250-HV, NV250-SEV NV250-HEV		
ST-2SV4	4				
ST-4SW2	2	NF400-CW, NF400-SW NF400-SEW, NF400-HEW NF400-REW	—	★Bar studs ●Insulating bases (2-pole: 4 pcs, 3-pole: 6 pcs, 4-pole: 8 pcs) ●Bar studs (2-pole: 4 pcs, 3-pole: 6 pcs, 4-pole: 8 pcs) ●Mounting screws, bolts and nuts	
ST-4SW3	3		NV400-CW, NV400-SW NV400-SEW NV400-HEW		
ST-4SW4	4				
ST-6SW2	2	NF630-CW, NF630-SW NF630-SEW, NF630-HEW NF630-REW	—	★Bar studs ●Insulating base (2 pcs) ●Bar studs (2-pole: 4 pcs, 3-pole: 6 pcs, 4-pole: 8 pcs) ●Mounting screws, bolts and nuts	
ST-6SW3	3		NV630-CW, NV630-SW NV630-SEW, NV630-HEW		
ST-6SW4	4				
ST-8SW2	2		NF800-SDW, NF800-CEW NF800-SEW, NF800-HEW NF800-REW		—
ST-8SW3	3	NV800-SEW, NV800-HEW			
ST-8SW4	4				

**Table 5-4 Plug-in type terminal blocks (PM)**

Type name	Number of poles	Applicable models		Major included parts
		MCCB	ELCB	
PMDN-05SV2L	2P	NF32-SV NF63-CV/SV/HV (3A-50A)	—	Plug-in type terminal block (1 pc) Crip terminals (2-pole: 4pcs, 3-pole: 6 pcs, 4-pole: 8 pcs)
PMDN-05SV3L	3P		NF32-SV NF63-CV/SV/HV (3A-50A)	
PMDN-05SV4L	4P	—		
PMDN-05SV2H	2P	NF63-CV/SV/HV (60A, 63A)		
PMDN-05SV3H	3P		NV63-CV/SV/HV (60A, 63A)	
PMDN-05SV4H	4P	—		
PMDN-1SV2	2P	NF125-CV/SV	—	Plug-in type terminal block (1 pc) Crip terminals (2-pole: 4 pcs, 3-pole: 6 pcs, 4-pole: 8 pcs)
PMDN-1HV2	2P	NF125-HV	—	
PMDN-1SV3	3P	NF125-CV/SV/HV	NV125-CV/SV/HV	
PMDN-1SV4	4P			
PMDN-1UV2	2P	NF125-UV	—	Plug-in type terminal block (2 pc) Crip terminals (2-pole: 4pcs, 3-pole: 6 pcs)
PMDN-1UV3	3P		—	
—	4P		—	
PMDN-2SV2	2P	NF125-SEV/HEV/SGV/LGV/HGV NF160-SGV/LGV/HGV NF250-CV/SV/HV/SEV/HEV/SGV/LGV/HGV	—	Plug-in type terminal block (1 pc) Plug-in type barriers (2-pole: 2 pcs, 3-pole: 4 pcs, 4-pole: 6 pcs) Tulip terminals (2-pole: 4 pcs, 3-pole: 6 pcs, 4-pole: 8 pcs)
PMDN-2SV3	3P		NV125-SEV/HEV NV250-CV/SV/HV/SEV/HEV	
PMDN-2SV4	4P			
PMDN-2SV2	2P		NF125-RGV, NF250-RGV	
PMDN-2SV3	3P	—		
PMDN-2UV2	2P	NF250-UV		—
PMDN-2UV3	3P		—	
—	4P		—	
PMDN-4SW2	2P	NF400-CW/SW	—	Plug-in type terminal block (2 pcs) Plug-in type barriers (4 pcs) Tulip terminals (3-pole: 6 pcs)
PMDN-4SW3	3P	NF400-CW/SW/SEW	NV400-CW/SW/SEW	
	3P	NF400-HEW/REW	NV400-HEW	
PMDN-4SW4	4P	NF400-SW/SEW	NV400-SEW	
	4P	NF400-HEW	—	
PMDN-8SW2	2P	NF800-SDW	—	Plug-in type terminal block (2 pcs) Tulip terminals (3-pole: 6 pcs)
PMDN-8SW3	3P	NF800-CEW/SEW	NV800-SEW	
	3P	NF800-HEW/REW	NV800-HEW	
PMDN-8SW4	4P	NF800-SEW	—	
	4P	NF800-HEW	—	

Note In addition to the circuit breakers shown above, 4-pole and 2-pole circuit breakers are available. We are ready to manufacture such circuit breakers to order. Please consult us.

### 3. Standard Tightening Torque

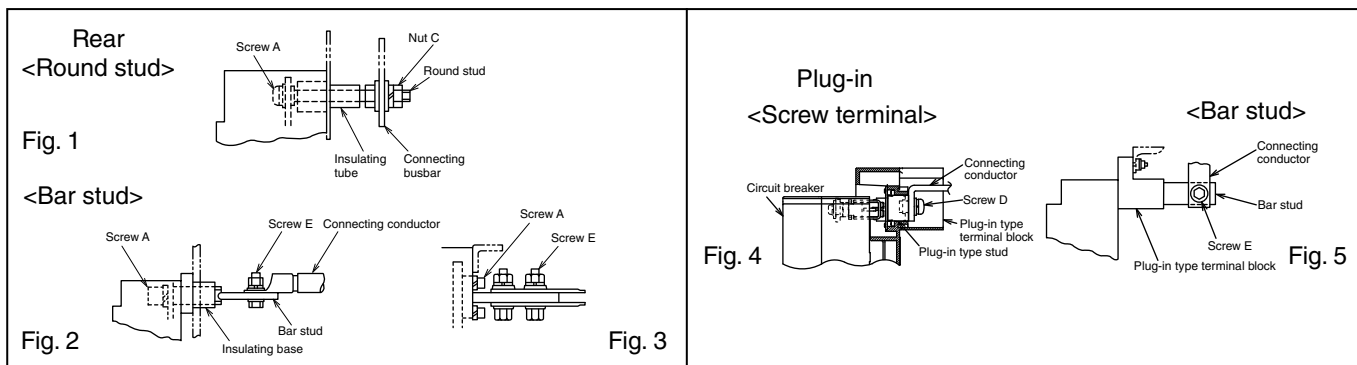

Table 5-5 Standard tightening torque (\*1)

Tightening torque N·m

Model	Connection type	Rear												Plug-in			
		Round stud				Bar stud				Screw terminal		Bar stud					
		Fig.1				Fig. 2, Fig.3				Fig.4		Fig.5					
		Screw A		Nut C		Screw A		Screw E		Screw D		Screw E					
MCCB	ELCB	Size	Tightening torque	Size	Tightening torque	Size	Tightening torque	Size	Tightening torque	Size	Tightening torque	Size	Tightening torque				
NF32-SV, NF63-CV NF63-SV, NF63-HV	NV32-SV, NV63-CV NV63-SV, NV63-HV	M4×0.7	1	M6	2	-	-	-	-	M6	3	-	-				
NF125-CV, NF125-SV NF125-HV, NF125-UV	NV125-CV, NV125-SV NV125-HV	-	-	-	-	M6	4	M8	12	M8	6	-	-				
NF125-SEV, NF125-HEV, NF125-RGV NF250-CV, NF250-SV, NF250-HV, NF250-SEV NF250-HEV, NF250-RGV, NF250-UV NF250-LGV/HGV, NF250-RGV, NF125-SGV/HGV NF125-LGV, NF160-SGV, NF160-LGV/HGV NF125-SGV, NF125-LGV, NF125-HGV NF160-SGV, NF160-LGV, NF160-HGV NF250-SGV, NF250-LGV, NF250-HGV	NV125-SEV, NV125-HEV NV250-CV, NV250-SV NV250-HV, NV250-SEV NV250-HEV	-	-	-	-	M6	10	M8	12	-	-	M8	12				
NF400-CW, NF400-SW, NF400-SEW NF400-HEW, NF400-REW NF400-UEW (3P)	NV400-CW, NV400-SW NV400-SEW, NV400-HEW	-	-	-	-	M8	20	M12	45	-	-	M12	45				
NF400-UEW (4P)	-	-	-	-	-	M10	30	M12	45	-	-	M12	45				
NF630-CW, NF630-SW, NF630-SEW NF630-HEW, NF630-REW	NV630-CW, NV630-SW NV630-SEW NV630-HEW	-	-	-	-	M8	20	M12	45	-	-	M12	45				
NF800-CEW, NF800-SDW NF800-SEW, NF800-HEW, NF800-REW NF800-UEW (*2)	NV800-SEW NV800-HEW	-	-	-	-	M10	30	2-M12	45	-	-	2-M12	45				
NF1000-SEW NF1250-SEW NF1600-SEW	-	-	-	-	-	4-M8	12	2-M12	45	-	-	2-M12	45				
NF1600-SEW	-	-	-	-	-	4-M8	12	4-M10	25	-	-	-	-				

Notes \*1 The appropriate range of tightening torque is ±20% of each value (standard tightening torque) shown in the above table. Please refer to the supplied assembly manual and instruction manual for more information.  
\*2 The plug-in type is not available.

## 4. Crimp Terminal Type

As the terminals in   , commercially available crimp terminals can be used. Please purchase the terminals at an electric material store.

For others, the crimp terminals for MCCB must be used. Place an order with us.

For the connection types shown in Fig. a and Fig. b, only crimp terminals will be delivered.

**Table 5-6 List of applicable crimp terminals**

Frame (A)	Nominal sectional area mm <sup>2</sup>		2	5.5	8	14	22	
	Allowable current (600V, IV wire at 30°C, not in conduit) (*4)		27A	49A	61A	88A	115A	
	Model		Size of mm <sup>2</sup>					
MCCB		ELCB						
			1.04 to 2.63	2.63 to 6.64	6.64 to 10.52	10.52 to 16.78	16.78 to 26.66	
30	NF30-FAU	NV30-FAU	R-2-5	R-5.5-5	JST8-5NS			
50	NF50-FAU	NV50-FAU	R-2-5	R-5.5-5	JST8-5NS	JST14-5NS	JST22-5NS (*5)	
100	NF100-FHU	NV100-FHU			R-8-8	R-14-8	R-22-8	
30	NF32-SV, NF50-FHU, NF63-CV* NF63-HV*	NV32-SV, NV50-FHU, NV63-CV* NV63-SV*, NV63-HV*	R-2-5 *(R-2-6)	R-5.5-5 *(R-5.5-6)	R-8-5	R-14-5	JST22-S5 BH-22 (L330T459-23) (*6)	
32								
50	*50A or below	*50A or below						
60	NF63-CV, NF63-SV, NF63-HV	NV63-CV, NV63-SV, NV63-HV	R-2-8	R-5.5-8	R-8-8	R-14-8	R-22-8	
63	60, 63A	60, 63A						
125	-	-	R-2-5 (R-2-6)	R-5.5-5 (R-5.5-6)	R-8-5	R-14-5	JST22-S5 (L330T459-23)	
	NF125-CV, NF125-SV, NF125-HV, NF125-UV 60A or more	NV125-CV, NV125-SV, NV125-HV 60A or more	R-2-8	R-5.5-8	R-8-8	R-14-8	R-22-8	
125	NF125-SEV, NF125-HEV, NF125-RGV NF250-CV, NF250-SV, NF250-HV, NF250-UV NF250-SEV, NF250-HEV, NF250-RGV NF125-SGV, NF160-SGV, NF250-SGV NF125-LGV, NF160-LGV, NF250-LGV NF125-HGV, NF160-HGV, NF250-HGV	NV125-SEV, NV125-HEV NV250-CV, NV250-SV, NV250-HV NV250-SEV, NV250-HEV				R-14-8	R-22-8	
225								
250								
400	NF400-CW, NF400-SW, NF400-SEW NF400-HEW, NF400-REW, NF400-UEW NF630-CW, NF630-SW, NF630-SEW NF630-HEW, NF630-REW	NV400-CW, NV400-SW NV400-SEW, NV400-HEW NV630-CW, NV630-SW, NV630-SEW, NV630-HEW						
600								
630								
800	NF800-CEW, NF800-SEW, NF800-HEW NF800-REW, NF800-UEW, NF800-SDW NF1000-SEW, NF1250-SEW	NV800-SEW, NV800-HEW						
1000								
1200								
1250								

Notes \*1 When using 2CR-150 or CB150-S8, insulate it from TC-S with insulating tube or tape. When using CB150-S8 for a 2- or 3-pole circuit breaker, TCL-2SV3L is applicable.

\*2 On the power supply side, pan-head screws M5 are used.

\*3 When tightening a terminal screw without connecting a wire, crimp terminal or bar, tighten the screw to 20 to 30% of the torque shown in the above table (to prevent damage to the threads).

\*4 The table shows not the allowable current values of circuit breakers, but those of wires applicable to crimp terminals.



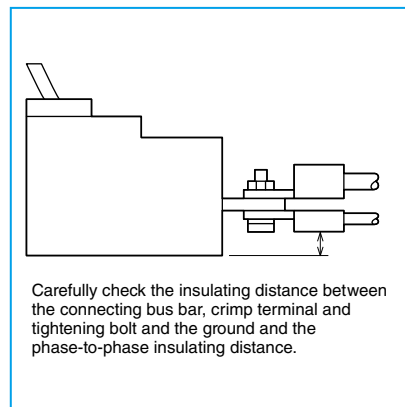
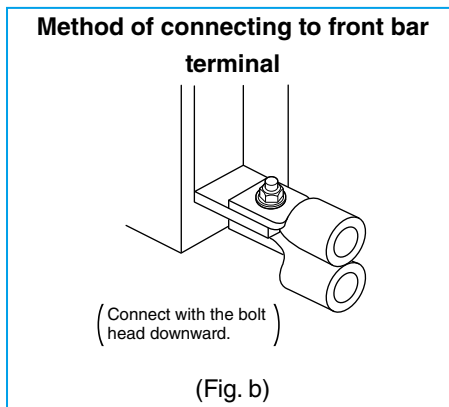
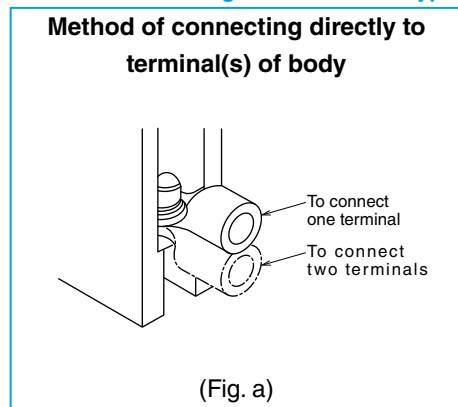

\*5 When using JST22-5NS, TC-S and RTC cannot be used. Insulate it with insulating tape or the like.

\*6 When using JST22-5S and BH-22 with NF/NV50-FHU type, TC-S cannot be used. Insulate with insulating tape or the like.

### Reference drawings of connection types

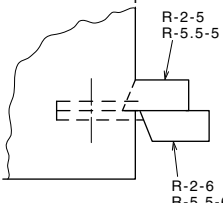

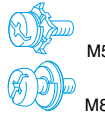
<Explanation of abbreviations> R .....Product specified by JIS  
 CB .....Product specified by JEM 1399  
 TE .....Product made by Tyco Electronics  
 JST .....Product made by J.S.T. Mfg. Co., Ltd.  
 NTM .....Product made by Nichifu Co., Ltd.  
 DST .....Product made by Daido Solderless Terminal Mfg. Co., Ltd.

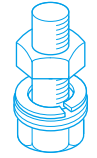
	38	60	100	150	200	325	Crimp terminal tightening screw			Remarks	Reference drawing of connection type
	162A	217A	298A	395A	469A	650A	Screw size	Tightening torque N·m	Shape		
	26.66 to 42.42	42.42 to 60.57	96.3 to 117.2	117.2 to 152.05	192.6 to 242.27	242.27 to 325	M5	2.5 ± 0.5	 M5 • M6	When connecting two crimp terminals, set the terminals as shown below if the *-marked terminals are used.  (Fig. a)	
TE #322870 JST 38-S8 NTM R38-8S	1AF-60 (L330T459-12) CB60-S8						M5	2.5 ± 0.5			
							M5	2.5 ± 0.5			
							M8	6 ± 1	 M8		
TE #322870 JST 38-S8 NTM R38-8S	1AF-60 (L330T459-12) CB60-S8						M8	6 ± 1			
							M5	2.5 ± 0.5	 M5 M8		
TE #322870 JST 38-S8 NTM R38-8S	1AF-60 (L330T459-12) CB60-S8						M8	6 ± 1			
R-38-8	R-60-8	2AF (LN300T920-20) CB100-S8	2CR-150(*1) (LN300T920-21) (*1)CB150-S8				M8	10.5 ± 2.5		When using 2AF, use a crimp tool having a nominal size of 100.	
R-38-12	R-60-12	R-100-12	R-150-12	R-200-12	JST325-12		M12	45 ± 5		Fit to a front type bar terminal. Up to two pieces can be fitted to one terminal.	(Fig. b)
R-38-12	R-60-12	R-100-12	R-150-12 RD150-12 SD150-12	R-200-12 RD200-12 SD200-12	JST325-12 RD325-12 SD325-12						

Remark: 1. For the crimp terminals for UL listed circuit breakers, refer to the page of the characteristics and external dimensions of UL 489 Listed Circuit Breakers.

● Dimensions of crimp terminals <extracted from catalog of JST>

Part number	Shape	Applicable screw size	External dimensions						Applicable wire mm <sup>2</sup>
			φd2	B	L	F	E	Thickness	
R2-5	A	M5	5.3	9.5	16.8	7.3	4.8	0.8	1.04 to 2.63
R2-6		M6	6.4	12.0	21.8	11.0			2.63 to 6.64
R2-8		M8	8.4	15.0	28.0	13.7			6.64 to 10.52
R5.5-5	A	M5	5.3	9.5	19.8	8.3	6.8	1.0	2.63 to 6.64
R5.5-6		M6	6.4	12.0	25.8	13.0			6.64 to 10.52
R5.5-8		M8	8.4	15.0	28.0	13.7			10.52 to 16.78
R8-5	A	M5	5.3	12.0	23.8	9.3	8.5	1.2	6.64 to 10.52
8-5NS		M5	5.3	9.0	22.3				10.52 to 16.78
R8-6		M6	6.4	12.0	23.8				16.78 to 26.66
R8-8		M8	8.4	15.0	29.8				13.8
8-5 SC-9		M5	5.3	9	23.8	9.3	8.5	1.2	6.64 to 10.52
R14-5	A	M5	5.3	12.0	29.8	13.3	10.5	1.5	10.52 to 16.78
14-5NS		M5	5.3	9.0	28.3				16.78 to 26.66
R14-6		M6	6.4	12.0	29.8				26.66 to 42.42
R14-8		M8	8.4	16.0	32.8				14.5
L330T459-23	A	M5	5.3	12.0	30.0	12.0	12.0	1.8	16.78 to 26.66
22-5NS		M5	5.3	9.5	28.7				26.66 to 42.42
22-S6		M6	6.4	12.0	30.0	14.0	1.8	2.0	42.42 to 60.57
R22-8	M8	8.4	16.5	33.7	13.5				60.57 to 96.3
R22-12	M12	13.0	22.0	42.5	19.5				96.3 to 117.2
38-S8	A	M8	8.4	15.5	38.0	16.0	14.0	1.8	26.66 to 42.42
R38-8		M8	8.4	42.7	17.7	42.42 to 60.57			
R38-12		M12	13.0	22.0	42.7	17.7			60.57 to 96.3
L330T459-12	A	M8	8.4	16.0	46.7	20.7	18.0	2.0	42.42 to 60.57
R60-8		M8	8.4	22.0	49.7	20.7			60.57 to 96.3
R60-12		M12	13.0	22.0	49.7	20.7			96.3 to 117.2
LN300T920-20	B	M8	8.4	22.5	51.0	20.0	21.0	2.6	96.3 to 117.2
R100-12	A	M12	13.0	28.5	55.6	20.4			117.2 to 152.05

Part number	Shape	Applicable screw size	External dimensions						Applicable wire mm <sup>2</sup>	
			φd2	B	L	F	E	Thickness		
LN300T920-21	B	M8	8.4	22.5	70.0	33.0	27.0	3.2	117.2 to 152.05	
L330T402-8		M8	8.4	25.3	61.5	23.0			152.05 to 192.6	
R150-12	A	M12	13.0	36.0	66.0	21.0	4.0	4.5	192.6 to 242.27	
R200-12	A	M12	13.0	44.0	78.0	24.5	31.5	4.0	242.27 to 325	
325-12	A	M12	13.0	50.5	88.0	33.5	35.5	4.5	325 to 424.2	
CB60-S8	B	M8	8.4	16.0	46.7	20.7	18.0	2.0	2.0	42.42 to 60.57
CB100-S8			8.4	22.0	52.5	20.5	21.0	2.6	2.6	96.3 to 117.2
CB150-S8			8.4	22.0	61.0	23.0	27.0	3.2	3.2	117.2 to 152.05

Part number	Shape	Applicable screw size	External dimensions							Applicable wire mm <sup>2</sup>	
			φd2	B	L	F	E	N	Thickness		
RD60-12	C	M12	14.0	22.0	89.0	20.0	18.0	40	2.0	42.42 to 60.57	
RD100-12			14.0	28.5	95.5	20.3	21.0			2.6	96.3 to 117.2
RD150-12			14.0	36.0	106.0	21.0	27.0			3.2	117.2 to 152.05
RD200-12			14.0	44.0	116.5	23.0	31.5			4.0	192.6 to 242.27
RD325-12			14.0	50.5	123.8	23.0	35.5			4.5	242.27 to 325
SD150-12	C	M12	14.0	36.0	107.0	29.0	28.0	32	4.0	117.2 to 152	
SD200-12			14.0	44.0	108.0	36.0	32.0			4.0	192.6 to 242.2
SD325-12			14.0	50.5	125.0	38.0	37.0			4.5	242.2 to 325

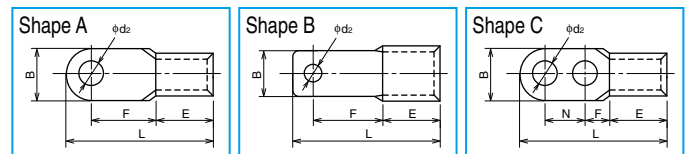

## 5. Busbar

The size of the conductor that can be connected is shown on the outline drawing of each model. The following special busbars are available. Use them as needed. When using any busbar, isolate it from the bare busbar on the circuit breaker power supply side with an insulating barrier.

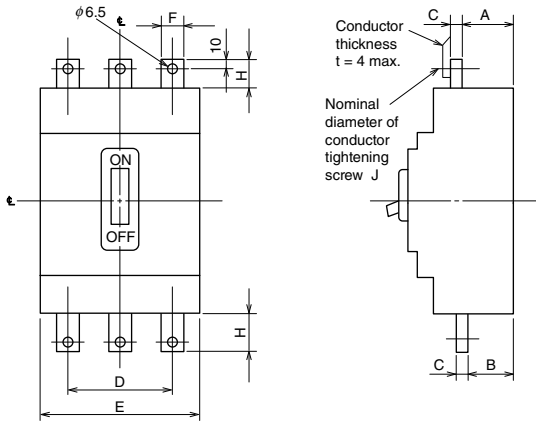

Fig. 1

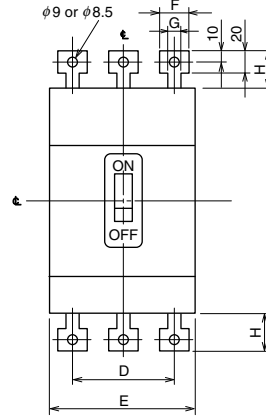

Fig. 2

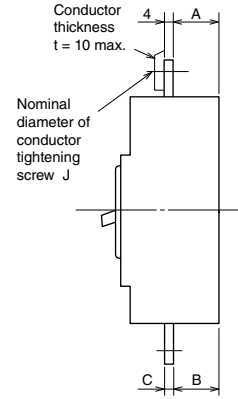

Fig. 3

Table 5-7 Table of variable dimensions

Type name	Applicable models		Outline and dimensions	Busbar									
	MCCB	ELCB		Fig.	A	B	C	D	E	F	G	H	J
FB-05SV	NF32-SV NF63-CV (50A or below) NF63-SV (50A or below) NF63-HV (50A or below)	NV32-SV NV63-CV (50A or below) NV63-SV (50A or below) NV63-HV (50A or below)		1	24	24	2	50	75	11.5	-	25	M5x0.8
FB-1SV	NF125-CV, NF125-SV NF125-HV, NF125-UV	NV125-CV NV125-SV NV125-HV		2	24	24	4	60	90	18	15	29	M8
FB-2SV	NF125-SEV NF125-HEV, NF125-RGV NF250-CV, NF250-SV, NF250-HV NF250-UV, NF250-SEV NF250-HEV, NF250-RGV NF125-SGV/LGV/HGV NF160-SGV/LGV/HGV NF250-SGV/LGV/HGV	NV125-SEV NV125-HEV NV250-CV, NV250-SV NV250-HV, NV250-SEV NV250-HEV		3	24	24	6	70	105	20	-	37	M8

## 6. Insulation Distance on Power Source Side

### ● Basic concept

#### Insulation distance (distance indicated in standards)

Be sure to at least secure the insulation distances (spatial distance and creeping distance) specified by the codes and standards of the relevant equipment and facilities where the circuit breakers are installed.  
It is recommended that insulation barriers and insulation tape be used to enhance the electrical insulation between bare-live parts and between bare-live parts and ground to avoid accidents otherwise caused by a loose metal piece, conductive dust, abnormal surge voltage in the circuit or a similar event so as to improve the reliability of panels.

#### Insulation distance

At the exhaust outlet side of breaker, arc space is necessary. When the actual load circuit is opened, especially when a large current such as overload or short-circuit is interrupted, ionized gas is emitted from the exhaust outlet. This gas can cause a short circuit between bare, live parts such as busbars, and also can cause grounding faults between conductive installation metal panels.

Therefore, it is important to secure enough arc space at the exhaust outlet side of the breaker and to strengthen insulation of parts exposed to the gas. In addition, securing enough space at the front of the exhaust outlet is necessary, because when the gas emission is blocked, failures such as deterioration of breaking performance can be caused.

### ● Insulation required part

With regard to insulation of bear, live parts of the line side of the breaker, please make sure to insulate at least C part C indicated in the diagram above with insulation tape, a tube or a terminal cover.

- ① A : Distance from the circuit breaker to the ceiling plate
- ② B1 : Distance from the circuit breaker to the uncovered conducting part of the upper circuit breaker terminal (front connection)
- ③ B2 : Distance from the lower circuit breaker to the end face of the upper circuit breaker (rear connection)
- ④ D1 : Distance from the side of the breaker to the side plate
- ⑤ C : Insulated length of the power source terminal of the circuit breaker (front connection)

Please secure insulation using insulating tape, insulating tubing, insulation barrier, or a terminal cover, between bare charge parts within this size range. Please refer to a table a necessary size must.

◇ When using insulation tape and insulation tubing together with insulation barriers and terminal covers, make them overlap with the other by at least 10mm.

◇ For the models with insulation barriers supplied as standard, please make sure to use the barriers.

a : clearance specified in standard

⑥ D2 : Side-to-side spacing of breakers

While the circuit breakers can basically be installed together without a clearance in between, be sure to observe the following instructions.

◇ It is desirable to install an insulation barrier between the adjacent circuit breakers or insulate the bare-live parts considering the effect of cutoff gas.

◇ Be sure to secure the insulation distance (dimension a) as the minimum, indispensable requirement.

◇ With a leakage circuit breaker and a leakage alarm circuit breaker installed in close contact with the other, a current of 2,500A or higher flowing through one of the circuit breakers could cause the other to operate falsely. Be sure to secure a distance of at least 50mm in between.

◇ A circuit breaker of 400 ampere frame or larger with an SHT or a UVT could operate falsely if a current of 50kA or higher flows through the adjacent circuit breaker. Be sure to secure a distance of at least 50mm in between.

◇ The Measuring Display Unit Breakers must not be installed in close contact.

To allow routing of the connection cables and installation of their connectors, provide the following clearance to the right side of the breaker when installing:

◆ External mounting or Panel mounting: 30mm or more

◆ Breaker mounting or Breaker mounting unit separate installation: 40mm or more

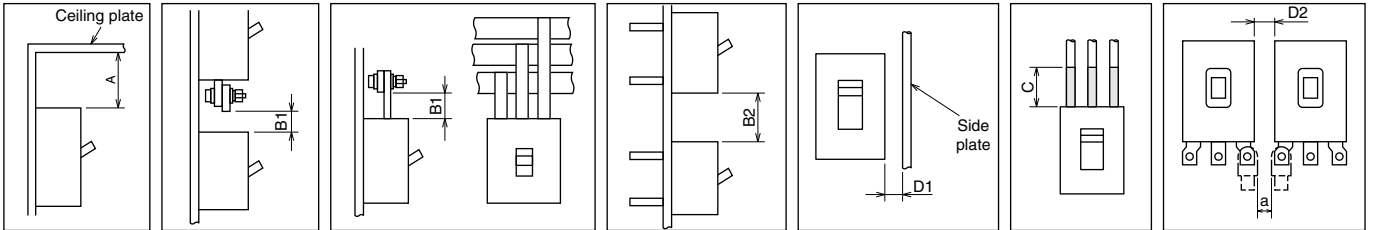

Table 5-8 Insulation distance (mm) (440VAC or below) \*Figures in parentheses are for 230VAC or below.

Class • Series	Model		Ceiling plate			Vertical spacing		C	Horizontal spacing D1
	MCCB	ELCB	A		B1, B2				
			Without terminal cover	With terminal cover	Without terminal cover	With terminal cover			
C • S • H • R • MB	NF30-FAU, NF50-FAU, NF50-FHU, NF100-FHU	NV30-FAU, NV50-FAU, NV50-FHU, NV100-FHU	10	10	10	20	20	(*)	20
	NF32-SV, NF63-CV	NV63-CV	5	5	5	20	20	(*)	20
	NF63-SV, NF63-HV	NV32-SV, NV63-SV, NV63-HV	10	10	10	30	30	30	25
	NF125-CV	NV125-CV	50(30)	40(30)	10	50	50	(*)	25
	NF125-SV	NV125-SV	50(10)	30(10)	10	50	50	50	25
	NF125-HV	NV125-HV	50	40	40	80	80	80	40
	NF250-CV	NV250-CV	40	40	40	50	50	50	50
	NF125-SEV, NF250-SV, NF250-SEV	NV125-SEV, NV250-SV, NV250-SEV	70(40)	40	40	70(50)	50	70(50)	50
	NF125-SGV, NF160-SGV, NF250-SGV								
	NF125-HEV, NF250-HV, NF250-HEV								
	NF125-LGV, NF160-LGV, NF250-LGV	NV125-HEV, NV250-HV, NV250-HEV	80	60	60	80	80	80	60
	NF125-HGV, NF160-HGV, NF250-HGV								
	NF400-CW	NV400-CW	60	60	60	60	60	60	40
	NF400-SW, NF400-SEW	NV400-SW, NV400-SEW	70	70	70	70	70	70	70
	NF400-HEW, NF400-REW	NV400-HEW	200	200	200	200	200	200	150
NF630-SW, NF630-SEW, NF630-CW	NV630-CW, NV630-SW, NV630-SEW	70	70	70	70	70	70	70	
NF630-HEW, NF630-REW	NV630-HEW	200	200	200	200	200	200	150	
NF800-SEW, NF800-CEW	NV800-SEW	80	80	80	80	80	80	80	
NF800-HEW, NF800-REW	NV800-HEW	200	200	200	200	200	200	150	
NF1000-SEW, NF1250-SEW									
NF1600-SEW		100	100	100	100	100	100	100	
R • U	NF125-RGV, NF250-RGV		30 (*6)	30 (*6)	30 (*6)	50 (*9)	50 (*9)	50	5
	NF125-UV, NF250-UV		(*)	(*)	(*)	(*)	(*)	(*)	25
	NF400-UEW		70	70	70	70	70	70	70
	NF800-UEW		80	80	80	80	80	80	80
CP	CP30-BA, CP30-HU		10 (*6)	10 (*6)	10 (*6)	20	20	(*)	20
	NF50-SMU		(10)	(10)	(10)	(20)	(20)	(20)	(10)
UL	NF100-SRU	NV100-SRU	30(10)(*6)	30(10)(*6)	10(*6)	50(*7)	50(*7)	50(*7)	10
	NF100-HRU(*4)	NV100-HRU(*4)	60(10)(*6)(*7)	60(10)(*6)(*7)	10(*6)	70(*6)(*7)	70(*6)(*7)	70(*6)(*7)	10
	NF50-SVFU		10 (*6)	10 (*6)	10 (*6)	20 (*7)	20 (*7)	30	10
	NF250-CVU	NV250-CVU	(40)	(40)	(40)	(50)	(50)	(50)	(20)
	NF100-CVFU		50(25)	40(25)	10	50	50	50	25(15)
	NF125-SVU(*4)		40(10)	30(10)	10	50	50	50	25(20)
	NF125-HVU(*5)		40	40	40	80	80	80	25(20)
	NF250-SVU(*4)		40	40	40	70(50)	50	70(50)	50(20)
	NF250-HVU(*5)		40	40	40	80	80	80	50(20)
	NF400-SWU, NF400-HWU(*5)		70	70	70	70	70	70	70
	NF630-SWU, NF630-HWU(*5)		70	70	70	70	70	70	70

Remark: 1. The table shows the dimensions in the case of the use of a large terminal cover (TC-L).

Notes \*1 It is not necessary to provide an insulation distance (an arc space) on the power supply side. However, if a grounding metal piece or the like comes in close contact with the terminal, be sure to completely insulate the terminals or the bare-live parts of the cable conductors.

\*2 At more than 440VAC, the distance shall be 10mm.

\*3 For 480Y/277VAC.

\*4 For 480VAC.

\*5 For 600Y/347VAC.

\*6 An exhaust port is provided also on the circuit breaker load side. Secure the dimension A both on the power supply side and on the load side.

\*7 When any of the circuit breakers NF125-RGV to NF250-RGV is used on the upstream side, an exhaust port is provided also on the circuit breaker load side. Secure the larger distance of the dimension B1 of NF125-RGV, NF250-RGV or NF50-SVFU and the dimension B1 of the downstream circuit breaker.

## 7. Effect of Installation Orientation

Installation orientation does not affect the operating characteristics of circuit breakers of electronic or thermo-magnetic operation types. However, the installation orientation affects the operating current of fully magnetic type circuit breakers as the iron core in the oil dash pot is under gravitational force. It is generally suggested they be installed vertically.

### ●Hydraulic-magnetic (The same applies to other models of hydraulic-magnetic type.)

MCCB		ELCB	
Class	Model	Class	Model
S-H	NF100-SRU, NF100-HRU	S-H	NV100-SRU, NV100-HRU
FH	NF50-FHU, NF100-FHU	FH	NV50-FHU, NV100-FHU

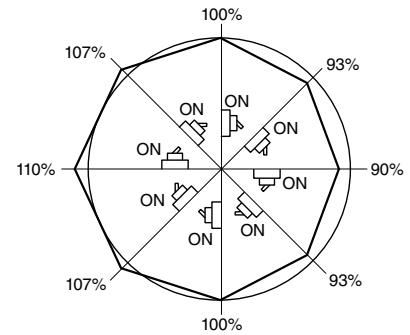

Rate of change of rated current by mounting angle

## 8. Connection of Line and Load

The standard wiring of line and load on the circuit breaker is as shown in (a) normal connection on the right.

Avoid the wiring shown in (b) reverse connection. This may lead to a decrease in breaking performance.

However, the reverse connection is allowed for the following models (excluding MDU breakers).

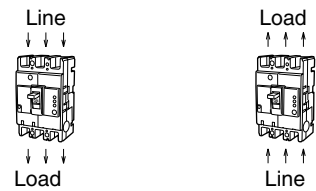

(a) Normal connection (b) Reverse connection

Connection methods

NF-C, NF-S, NF-H, NF-R and NF-U class CP30-BA, CP30-HU, NV-C, S, H and R class of 400 to 800AF, NF100-CVFU, NF100-SRU, NF100-HRU, NF125-SVU, NF125-HVU, NF250-CVU, NF250-SVU, NF250-HVU, NF400-SWU, NF400-HWU, NF630-SWU, NF630-HWU	Reverse connection is allowed for the standard models.
--	--

# 6

## Accessories

### **1 Internal Accessories** **108**

---

1) Internal Accessories .....	108
2) Terminal Symbols .....	109
3) Operations and Ratings of Switches .....	109
4) Maximum Number of Internal Accessories .....	110
5) Cassette Type Accessories .....	115
6) Shunt Trip (SHT) .....	117
7) Undervoltage Trip (UVT) .....	118
8) Lead Wire Drawing .....	120
9) Lead Wire Terminal Block .....	120
10) Test Button Module (TBM) .....	121
11) Pre-Alarm Module (PAL) .....	122

### **2 External Accessories** **123**

---

1) F-type Operating Handle (Breaker Mount Type) .....	123
2) V-type Operating Handle (Door Mount Type) .....	125
3) C-type Operating Handle.....	127
4) Terminal Covers .....	128
5) Insulating Barriers.....	131
6) Handle Lock Devices, Lock Covers, Auxiliary Handles, Card Holders .....	134
7) Mechanical Interlocks (MI) .....	136
8) Boxes for Circuit Breakers and Boxed Circuit Breakers .....	137
9) Electrical Operated Circuit Breakers and Electrical Operation Devices.....	140
10) IEC 35mm Rail Mounting Adapters .....	143

## 1. Internal Accessories

The accessories to be installed in circuit breakers include the followings. For the numbers of the accessories which can be installed, refer to the tables on pages 110 to 114. The standard internal accessories have lead wires (450mm in length) drawn out. (However, some of Models UVT and TBM have vertical lead wire terminal blocks as standard.) When circuit breakers are installed side by side, keep a space of 8mm or more for lead wires between the circuit breakers. (Models with lead wires drawn out toward load and models with lead wire grooves in the side faces can be installed in close contact.)

### SHT (Shunt trip)

Device to electrically trip a circuit breaker from a distance. The allowable operating voltage range is 70 to 110% of the rated voltage.

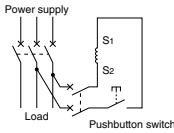

Connection diagram

### AL (Alarm switch)

Switch to electrically display the tripping status of circuit breaker.

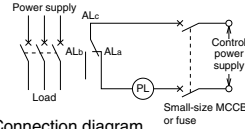

Connection diagram

### AX (Auxiliary switch)

Switch to electrically display the ON-OFF status of circuit breaker.

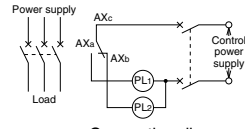

Connection diagram

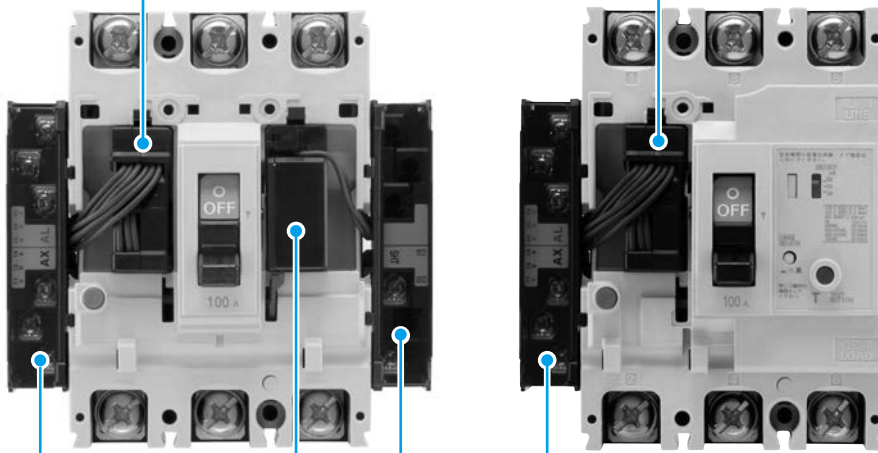

### UVT (Under voltage trip)

Device to automatically trip a circuit breaker when the voltage drops. The operating voltage is 70 to 35% of the UVT rated voltage. When the voltage recovers at least to 85% or more, the circuit breaker can be turned on after the device is manually reset.

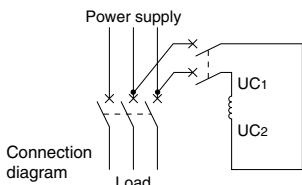

Connection diagram

### SLT (Lead wire terminal block)

Terminals for connecting with internal accessories. The terminal block will be manufactured to order. For the detailed dimensions, refer to pages 120 and 121. (The dimensions of SLT slightly vary depending on the number of installed accessories and the model.) However, circuit breakers with a frame size of 400A and above having an electrical operation device are normally provided with SLT.

### TBM (Test button module)



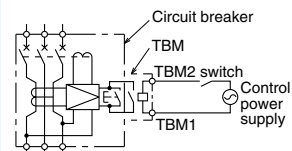

Unit to perform test under voltage from a distance. TBMs can be connected in parallel. (The standard TBMs are provided with SLT. In the case of the flush plate type, the external dimensions are partially different from those of the standard type.)

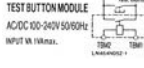

TBM circuit diagram

## 2. Terminal Symbols

Table 6-1

Accessory name	Nameplate (sample)	Accessory name	Nameplate (sample)
<b>AL</b> Alarm switch		<b>TBM</b> Test button module	
<b>AX</b> Auxiliary switch			
<b>SHT</b> Shunt tripping device			
<b>UVT</b> Undervoltage tripping device			

## 3. Operations and Ratings of Switches

Table 6-2 Operations of AL switch

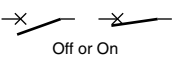
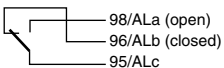
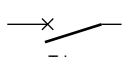
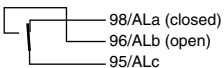
Status of circuit breaker	Contact status of AL switch
 Off or On	 98/ALa (open) 96/ALb (closed) 95/ALc
 Trip	 98/ALa (closed) 96/ALb (open) 95/ALc

\* The terminal numbers 98/ALa, 96/ALb and 95/ALc may vary depending on the number of installed switches and the installation poles.

Table 6-3 Operations of AX switch

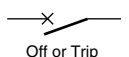
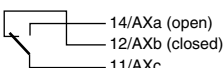
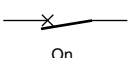
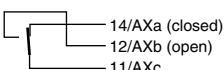
Status of circuit breaker	Contact status of AX switch
 Off or Trip	 14/AXa (open) 12/AXb (closed) 11/AXc
 On	 14/AXa (closed) 12/AXb (open) 11/AXc

\* The terminal numbers 14/AXa, 12/AXb and 11/AXc may vary depending on the number of installed switches and the installation poles.

Table 6-4 Ratings of AL-AX (Above 400A frame) switches

Applied switch	Voltage V	AC Current A		Voltage V	DC Current A	
		Resistive load	Inductive load		Resistive load	Inductive load
A	(250)	(1)	(0.5)	(50)	(1)	(0.5)
	125	3	(1)	30	2	(1)
S	460	—	—	250	0.2	0.2
	250	3	2	125	0.4	0.4
	125	5	3	30	4	3
V	460	5	2	250	0.3	0.3
	250	10	10	125	0.6	0.6
	125	10	10	30	10	6

Remarks: 1. The ratings in parentheses do not conform to UL.  
2. For the applied switches, refer to Tables 6-9 to 6-12-2.

Table 6-5 Ratings of corrosion resist AL and AX switches

Corrosion resist switch	Voltage V	AC Current A		Voltage V	DC Current A	
		Resistive load	Inductive load		Resistive load	Inductive load
ST	460	—	—	250	0.2	0.2
	250	3	2	125	0.4	0.4
	125	5	3	30	4	3
VT	460	1	0.5	250	0.3	0.3
	250	5	4	125	0.4	0.4
	125	5	4	30	5	3

Table 6-6 Ratings of small loads AL-AX switches

Switch	Voltage V	AC Current A		Voltage V	DC Current A	
		Resistive load	Inductive load		Resistive load	Inductive load
AB	125	0.1	—	30	(0.1)	—
SB	125	0.1	—	30	0.1	—
VB	125	0.1	—	30	0.1	—

Remark: 1. Ratings in parentheses are not subject to UL.

## 4. Maximum Number of Internal Accessories

### MCCB and Motor Protection Breakers

Table 6-7 Table of maximum number of internal accessories

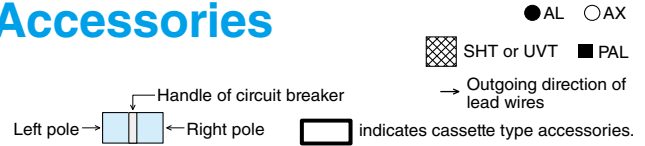

Model	C	NF63-CV NF125-CV	NF63-CV NF125-CV NF250-CV		NF400-CW NF630-CW	NF800-CEW	
	S	NF32-SV NF63-SV NF125-SV	NF32-SV NF63-SV NF125-SGV NF160-SGV NF250-SV NF250-SGV	NF125-SEV NF250-SEV	NF400-SW NF400-SEW NF630-SW NF630-SEW	NF800-SEW NF800-SDW	NF1000-SEW NF1250-SEW NF1600-SEW
L • H • R		NF63-HV	NF63-HV NF125-HV NF125-LGV NF125-HGV NF160-LGV NF160-HGV NF250-HV NF250-LGV NF250-HGV NF250-RGV	NF125-HEV NF250-HEV	NF400-HEW NF400-REW NF630-HEW NF630-REW	NF800-HEW NF800-REW	
	U		NF125-UV NF250-UV		NF400-UEW(3P)	NF400-UEW(4P) NF800-UEW	
HDV HDW HDVA		NF63-HDV	NF63-HDV(3P) NF125-HDVA(4P) NF250-HDVA(4P)		NF400-HDW(3P, 4P)	NF800-HDW(3P, 4P)	
Number of poles AL and AX (standard) switches		2 poles	2, 3 or 4 poles	3, 4 poles	2, 3 or 4 poles	2, 3 or 4 poles	2, 3 or 4 poles
Accessory		S					V
AL							
AX							
SHT or UVT							
AL + AX							
SHT + UVT							
SHT AL + or UVT							
SHT AX + or UVT							
AL + AX + SHT or UVT							
PAL (contact output)							

Notes

- \*1 When UVT is provided, the UVT voltage module will come in the vertical lead wire terminal block type. (SHT does not have a voltage module.)
- \*2 The second AX can be installed in place of the AL on the left pole side. When placing an order, specify the incorporation of the switches in the body.
- \*3 PAL (contact output) can be installed together with AL and AX on the left pole side. (It cannot be installed together with SHT or UVT.) The standard type is provided with SLT. PAL control voltage (compatible with 100 to 200VAC) is necessary.
- \*4 SHT and UVT can be installed on the left side.
- \*5 SHT and UVT are normally installed on the right pole side. If you intend to install them on the left pole side, specify so. (The non-reset type UVT must be installed on the left pole side.)
- \*6 In the case where three or more accessories are installed on the left pole side and AL, AX or AL and AX are installed on the pole on which SLT, SHT or UVT is installed, the SLT will be manufactured to order.
- \*7 When AL, AX or AL and AX are installed on the pole on which UVT is installed, the UVT voltage module must be installed separately.
- \*8 SLT is provided as standard. A control power supply (100 to 200VAC) is required. (In this case, other internal accessories cannot be installed on the right pole side.)

Remarks: 1. For electrically operated automatic reset type circuit breakers having a frame size of 400A or above, the numbers of AL switches which can be installed are smaller by 1 than the values shown above.  
 2. The encircled numbers indicate the order of installation.  
 3. AL and AX for minute load can be manufactured to order.

**ELCB**

● AL ○ AX  SHT or UVT

**Table 6-8 Table of maximum number of internal accessories**

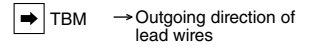
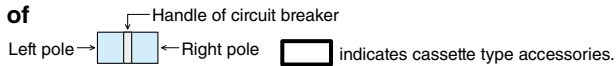

Model	C	NV63-CV NV125-CV NV250-CV	NV400-CW NV630-CW	
	S	NV32-SV NV63-SV NV125-SV NV125-SEV NV250-SV NV250-SEV	NV400-SW NV400-SEW NV630-SW NV630-SEW	NV800-SEW
H • R	NV63-HV NV125-HV NV125-HEV NV250-HV NV250-HEV	NV400-HEW NV630-HEW	NV800-HEW	
Number of poles Switch	2, 3, or 4 poles		3 poles	
Accessory	S			
AL				(*6)
AX				(*6)
AL + AX				(*6)
SHT or UVT				(*5)
SHT AL + or UVT				(*4) (*5) (*6)
SHT AX + or UVT				(*4) (*5) (*6)
SHT AL + AX + or UVT				(*4) (*5) (*6)
TBM				(*1)

- Notes \*1 The standard type is provided with SLT. Only in the case of 24VDC, specify the control voltage.  
 \*2 The second AX can be installed in place of the AL on the left pole side. When placing an order, specify the incorporation of the switches in the body.  
 \*3 When UVT is provided, the UVT voltage module will come in the vertical lead wire terminal block type. (SHT does not have a voltage module.)  
 \*4 When AL, AX or AL and AX are installed on the pole on which UVT is installed, the UVT voltage module must be separately installed.  
 \*5 When the accessory is provided with UVT, the UVT voltage module has a vertical lead wire terminal block. The UVT is not provided with a cassette.  
 \*6 SLT to be used when three or more accessories are installed on the left pole is manufactured to order.

- Remarks: 1. The encircled numbers indicate the order of installation.  
 2. TBM can be installed regardless of the number of installed AL, AX, SHT and UVT.  
 3. AL and AX for minute load can be manufactured to order.

# 6 Accessories 1 Internal Accessories

## UL Circuit Breakers

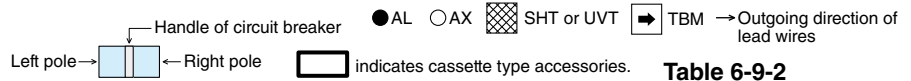

**Table 6-9-1 Table of maximum number of internal accessories**

Model	MCCB	NF30-FAU NF50-FAU	NF50-FHU NF100-FHU(3P)	NF100-SRU NF100-HRU		NF50-SVFU NF100-CVFU	NF50-SVFU NF100-CVFU	NF125-SVU NF125-HVU NF250-SVU NF250-HVU NF250-CVU	NF400-SWU NF400-HWU	NF630-SWU NF630-HWU
		2, 3 poles	2, 3 poles	2 poles	3 poles	2 poles	3 poles	2 or 3 poles	3 poles	3 poles
Number of poles AL and AX (standard) switches		A	S	A		S				
Accessory										
AL										
AX										
SHT or UVT										
AL + AX										
AL + SHT or UVT										
AX + SHT or UVT										
AL + AX + SHT or UVT										

**Table 6-9-2 Table of maximum number of accessories**

Model	NF	NF50-SMU
Number of poles AL and AX (standard) switches		1, 2, 3 poles
Accessory		-
AL		
AX		
SHT		
AL + AX		
AL + SHT		
AX + SHT		
AL + AX + SHT		

Model	ELCB	NV30-FAU NV50-FAU	NV50-FHU NV100-FHU(3P)	NV100-SRU NV100-HRU(3P)	NV50-SVFU	NV50-SVFU NV100-CVFU	NV125-SVU NV125-HVU NV250-SVU NV250-HVU
		2, 3 poles	2, 3 poles	2, 3 poles	2 poles	3 poles	3 poles
Number of poles AL and AX (standard) switches		A	S	A	S		
Accessory							
AL							
AX							
SHT or UVT							
AL + AX							
AL + SHT or UVT							
AX + SHT or UVT							
AL + AX + SHT or UVT							
TBM							

**Notes**

- \*1 When UVT is provided, the UVT voltage module will come in the vertical lead wire terminal block type. (SHT does not have a voltage module.)
- \*2 SHT cannot be installed.
- \*3 SHT and UVT are normally installed on the right pole side. If you intend to install them on the left pole side, specify so.
- \*4 In the case where three or more accessories are installed on the left pole side and AL, AX or AL and AX are installed on the pole on which SLT, SHT or UVT is installed, the SLT will be manufactured to order.
- \*5 When AL, AX or AL and AX are installed on the pole on which UVT is installed, the UVT voltage module must be installed separately.
- \*6 UVT of NF50-SVFU and NV50-SVFU are not provided with cassettes.
- \*7 The standard type is provided with SLT. Only in the case of 24VDC, specify the control voltage.
- \*8 UVT cannot be installed.
- \*9 Lead drawing is standard. Lead drawing is also available. For NF/NV100-FHU, Lead wires are usually extended load side.
- \*10 Lead drawing is not available.
- \*11 Left pole SHT and UVT are mounted on the side of circuit breaker.

**Remarks:**

1. The encircled numbers indicate the order of installation.
2. AL and AX for minute load can be manufactured to order. (These switches have been certified only by UL and CSA. They have not been certified by TUV.)

## MDU Breakers

Table 6-10-1 Table of maximum number of internal accessories

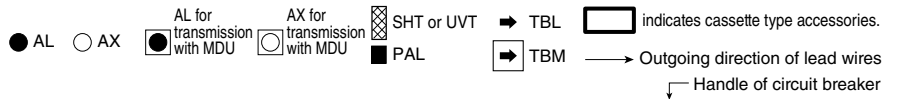

The numbers in ○ indicate the mounting order.

Model	NF250-SEV with MDU NF250-HEV with MDU
Number of poles	3, 4 poles
Switch	S
AL	*1
AX	*1
AL+AX	*1 *2
SHT	*1 *3
	*1 *3
UVT	*4
AL+SHT	*1
AX+SHT	*1
AL+AX+SHT	*1
AL+UVT	*4
AX+UVT	*4
AL+AX+UVT	*4

Model	NF250-SEV with MDU NF250-HEV with MDU
Number of poles	3, 4 poles
Switch	S
PAL	*5 With PAL contact
AL for transmission with MDU *6	*6
AX for transmission with MDU *6	*6
AL+AX for transmission with MDU *6	*6
AL+AX+AL for transmission with MDU *6	*1
AL+AX+AX for transmission with MDU *6	*1
AL+AX+AL+AX for transmission with MDU *6	*1

Notes:

- \*1 The right pole SLT specification is built into the main unit (not included with the cassette).  
When MDU specification is "Breaker mounting", "Breaker mounting unit separates".
- \*2. The second AX can be mounted in place of the AL on the left pole side. Please order with the built-in body.
- \*3. Left pole mounting is also possible.
- \*4. The UVT voltage module is a vertical lead wire terminal block type. UVT is not included with the cassette.

MDU installation type	UVT specification	Remarks
Breaker mounting	· UVT voltage module separate installation is standard. · In the case of separate display unit, UVT voltage module body mounting is also available.	Left pole mounting is also possible. (Reset type UVT can not be mounted on the left)
Breaker mounting unit separate installation		
External mounting	· UVT voltage module body mounting is standard.	
Panel mounting	· A separate UVT voltage module can also be manufactured.	

- \*5. It comes with a terminal block specification.  
A control power supply (100-240VAC/DC common) is required (In this case, other internal accessories can not be mounted on the right pole).  
When MDU specification is "Breaker mounting", "Breaker mounting unit separates".
- \*6. When transmitting AL, AX, AL + AX, AL and AX for MDU transmission are left pole mounted.  
In this case, AL and AX for MDU transmission installed on the left pole side can not be used for lead wire extraction and terminal block installation to the outside.

Remark:

- 1. AL and AX for minute load can be manufactured to order.

# 6 Accessories 1 Internal Accessories

## MDU Breakers

Table 6-10-2 Table of maximum number of internal accessories

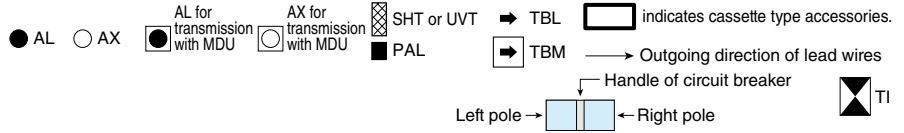

The numbers in ○ indicate the mounting order.

Model	NF400-SEW with MDU NF400-HEW with MDU	NF800-SEW with MDU NF800-HEW with MDU
Number of poles	3, 4 poles	
Switch	S	
AL		*1
AX		*1
SHT	*2	
UVT	*3 *4	
AL+AX	*1	
AL+SHT	*2	*1 *2
AX+SHT	*2	*1 *2
AL+AX+SHT	*1 *2	*1 *2
AL+UVT	*3 *4 *5	*1 *3 *4 *5
AX+UVT	*3 *4 *5	*1 *3 *4 *5
AL+AX+UVT	*1 *3 *4 *5	*1 *3 *4 *5

Model	NF400-SEW with MDU NF400-HEW with MDU	NF800-SEW with MDU NF800-HEW with MDU
Number of poles	3, 4 poles	
Switch	S	
PAL	*6	
TI	*6 With PAL: OAL contact	
AL for transmission with MDU *7		
AX for transmission with MDU *7		
AL+AX for transmission with MDU *7		
AL+AX+AL for transmission with MDU *7		
AL+AX+AX for transmission with MDU *7		
AL+AX+AL+AX for transmission with MDU *7		

Notes: \*1 When mounting 3 or more accessories on the left pole, SLT is manufactured upon order.

\*2 The right pole mounting is standard for SHT. Please specify for left pole installation.

\*3 The UVT voltage module is a vertical lead wire terminal block type. UVT is not included with the cassette. With embedded UVT, "UVT voltage module separate" Please specify

\*4 UVT is standard with right pole mounting. Please specify for left pole installation. (The reset prevention type UVT has a left pole mounting)

\*5 When mounting AL, AX, AL + AX on the same pole as UVT, the UVT voltage module is separate.

\*6 It comes with a terminal block specification. Control power supply (100-240VAC/DC shared) 5VA is required.

(In this case, other internal accessories can not be mounted on the right pole)

\*7 When transmitting AL, AX, AL + AX, AL and AX for MDU transmission are left pole mounted.

In this case, AL and AX for MDU transmission installed on the left pole side can not be used for lead extraction and terminal block installation to the outside.

MDU installation type	UVT specification	Remarks
Breaker mounting	· UVT voltage module separate installation is standard.	Left pole mounting is also possible. (Reset type UVT can not be mounted on the left)
Breaker mounting unit separate installation	· In the case of separate display unit, UVT voltage module body mounting is also available.	
External mounting	· UVT voltage module body mounting is standard.	
Panel mounting	· A separate UVT voltage module can also be manufactured.	

Remark: 1. AL and AX for minute load can be manufactured to order.

## 5. Cassette Type Accessories

The internal accessories for major models having a frame size from 30 to 800A come in cassettes, and they can be installed to and removed from circuit breakers by the user.

Some cassette type accessories have lead wires drawn out, and others have vertical lead wire terminal blocks (SLT). (These parts are supplied by 10 pieces for frame size from 30 to 250A or by 1 piece for frame size from 400 to 800A.)

### ■ Applicable models and kinds of cassette type accessories

	Model	Alarm switch (AL)	Auxiliary switch (AX)	Shunt tripping device (SHT)	Undervoltage tripping device (UVT)
MCCB	NF100-SRU, NF100-HRU NF63-CV~NF250-CV, NF32-SV~NF250-SV NF63-HV~NF250-HV NF125-SGV~NF250-SGV, NF125-LGV~NF250-LGV NF125-HGV~NF250-HGV NF125-SEV, NF250-SEV, NF125-HEV, NF250-HEV NF125-RGV, NF250-RGV, NF125-UV, NF250-UV NF100-CVFU, NF125-SVU/HVU, NF250-CVU/SVU/HVU	○	○	○	○
	NF50-SVFU, NF400-CW, NF630-CW, NF800-CEW NF400-SW, NF630-SW, NF400-SEW~NF800-SEW NF800-SDW, NF400-HEW~NF800-HEW NF400-REW~NF800-REW, NF400-UEW, NF800-UEW NF400-SWU/HWU, NF630-SWU/HWU	○	○	○	-
ELCB	NV100-SRU, NV100-HRU NV63-CV~NV250-CV, NV32-SV~NV250-SV NV63-HV~NV250-HV NV125-SEV, NV250-SEV, NV125-HEV, NV250-HEV NV100-CVFU, NV125-SVU/HVU, NV250-CVU/SVU/HVU	○	○	○	○
	NV50-SVFU, NV400-CW, NV630-CW NV400-SW, NV630-SW, NV400-SEW~NV800-SEW NV400-HEW~NV800-HEW	○	○	○	-

### ■ Procedure for installing cassette type accessories



1. Press the trip button (PTT) to trip the circuit breaker. (\*1)



2. Loosen the cover screws.

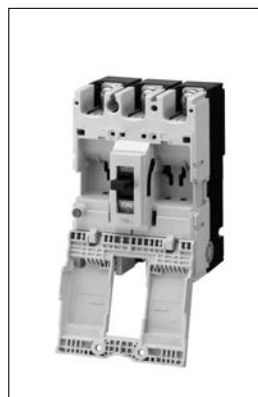

3. Open the cover.

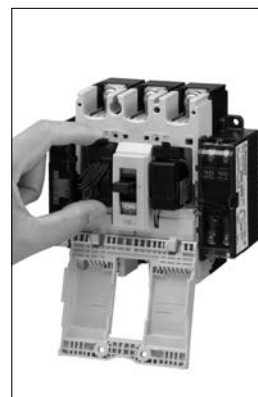

4. Install the cassette type accessory. (\*2)



5. Close the cover, and tighten the screws.

Notes \*1. When installing any cassette type accessory, set the circuit breaker to the tripped state.

\*2. If the inner lid or another accessory has been installed, remove it before installing the accessory.

When any circuit breaker supplied with the inner lid is used without an accessory, fit the inner lid without fail.

Failure to do so may affect the short-circuiting performance.

Models with inner lid: NF125-SV, NF125-HV, NF125-UV

NV125-SV, NV125-HV

NF250-SV, NF250-HV, NF250-CVU

NV250-SV, NV250-HV, NV250-CVU

NF125-SVU, NF125-HVU, NV125-SVU, NV125-HVU

NF250-SVU, NF250-HVU, NV250-SVU, NV250-HVU

NF125-SGV~NF250-SGV

NF125-LGV~NF250-LGV

NF125-HGV~NF250-HGV

NF250-SEV, NF250-HEV, NF250-UV

NV250-HEV

NF125-SEV, NF125-HEV

NV125-SEV, NV125-HEV

NF400-REW, NF400-UEW

NF630-REW

NF800-HEW, NF800-REW, NF800-UEW

NV800-HEW

NF630-SWU, NF630-HWU

### Cautions when installing

Before installing or removing any cassette type accessory, set the circuit breaker and accessories to the no-voltage state.

Never install a cassette type accessory while the handle is in the ON or OFF position. Doing so may damage the accessory.

When installing an accessory with lead wires drawn out, apply the supplied nameplate to the circuit breaker side face.

When installing an accessory with lead wires drawn out for a frame size of 400 to 800A, secure the lead wires along the circuit breaker side face with the supplied lead wire retainers.

## Type name

Table 6-11-1

Model		Installation pole	AL	AX	AL+AX	SHT	UVTN or UVTS	
MCCB	ELCB							
NF50-SVFU	NV50-SVFU	For right pole	AL-03SVU AL-03SVURS	AX-03SVU AX-03SVURS	ALAX-03SVU ALAX-03SVURS	SHTA240-03SVUR SHTA440-03SVUR SHTD100-03SVUR SHTA240-03SVURS SHTA440-03SVURS SHTD100-03SVURS	-	
		For left pole	AL-03SVU AL-03SVULS	AX-03SVU AX-03SVULS	ALAX-03SVU ALAX-03SVULS	SHTA240-03SVUL SHTA440-03SVUL SHTD100-03SVUL SHTA240-03SVULS SHTA440-03SVULS SHTD100-03SVULS	-	
NF32-SV, NF63-CV, NF63-SV, NF63-HV NF125-CV, NF125-SV, NF125-HV NF125-SGV, NF125-LGV, NF125-HGV NF160-SGV, NF160-LGV, NF160-HGV NF125-SEV, NF125-HEV NF125-RGV, NF125-UV NF250-CV, NF250-SV, NF250-HV NF250-SGV, NF250-LGV, NF250-HGV NF250-SEV, NF250-HEV NF250-RGV, NF250-UV		For right pole	AL-05SV AL-05SVRS	AX-05SV AX-05SVRS	ALAX-05SV ALAX-05SVRS	SHTA240-05SVR SHTA550-05SVR SHTD125-05SVR SHTA240-05SVRS SHTA550-05SVRS SHTD125-05SVRS	UVTNAD130-05SVR UVTNA250-05SVR UVTNA480-05SVR UVTNAD130-05SVRS UVTNA250-05SVRS UVTNA480-05SVRS	UVTSAD130-05SVR UVTSA250-05SVR UVTSA480-05SVR UVTSAD130-05SVRS UVTSA250-05SVRS UVTSA480-05SVRS
		For left pole	AL-05SV AL-05SVLS	AX-05SV AX-05SVLS	ALAX-05SV ALAX-05SVLS	SHTA240-05SVL SHTA550-05SVL SHTD125-05SVL SHTA240-05SVLS SHTA550-05SVLS SHTD125-05SVLS	UVTNAD130-05SVL UVTNA250-05SVL UVTNA480-05SVL UVTNAD130-05SVLS UVTNA250-05SVLS UVTNA480-05SVLS	UVTSAD130-05SVL UVTSA250-05SVL UVTSA480-05SVL UVTSAD130-05SVLS UVTSA250-05SVLS UVTSA480-05SVLS
NF100-CVUFU NF125-SVU/HVU NF250-CVU/SVU/HVU	NV100-CVUFU NV125-SVU/HVU NV250-CVU/SVU/HVU	For right pole	AL-05SVU AL-05SVURS	AX-05SVU AX-05SVURS	ALAX-05SVU ALAX-05SVURS	SHTA240-05SVUR SHTA550-05SVUR SHTD125-05SVUR SHTA240-05SVURS SHTA550-05SVURS SHTD125-05SVURS	UVTNAD130-05SVUR UVTNA250-05SVUR UVTNA480-05SVUR UVTNAD130-05SVURS UVTNA250-05SVURS UVTNA480-05SVURS	UVTSAD130-05SVUR UVTSA250-05SVUR UVTSA480-05SVUR UVTSAD130-05SVURS UVTSA250-05SVURS UVTSA480-05SVURS
		For left pole	AL-05SVU AL-05SVULS	AX-05SVU AX-05SVULS	ALAX-05SVU ALAX-05SVULS	SHTA240-05SVUL SHTA550-05SVUL SHTD125-05SVUL SHTA240-05SVULS SHTA550-05SVULS SHTD125-05SVULS	UVTNAD130-05SVUL UVTNA250-05SVUL UVTNA480-05SVUL UVTNAD130-05SVULS UVTNA250-05SVULS UVTNA480-05SVULS	UVTSAD130-05SVUL UVTSA250-05SVUL UVTSA480-05SVUL UVTSAD130-05SVULS UVTSA250-05SVULS UVTSA480-05SVULS
NF100-SRU NF100-HRU	NV100-SRU NV100-HRU	For right pole	AL-05SRU AL-05SRURS	AX-05SRU AX-05SRURS	ALAX-05SRU ALAX-05SRURS	SHTA240-05SRU SHTA480-05SRU SHTD125-05SRU SHTA240-05SRURS SHTA480-05SRURS SHTD125-05SRURS	-	
		For left pole	AL-05SRU AL-05SRULS	AX-05SRU AX-05SRULS	ALAX-05SRU ALAX-05SRULS	SHTA110-05SRULS SHTA127-05SRULS SHTA220-05SRULS SHTA240-05SRULS SHTD024-05SRULS SHTD110-05SRULS	UVTNA110-05SRULS UVTNA127-05SRULS UVTNA220-05SRULS UVTNA240-05SRULS UVTND024-05SRULS UVTND110-05SRULS	-
NF400-CW, NF400-SW, NF400-SEW NF400-HEW, NF400-REW, NF400-UEW NF630-CW, NF630-SW, NF630-SEW NF630-HEW, NF630-REW NF800-CEW, NF800-SDW, NF800-SEW NF800-HEW, NF800-REW, NF800-UEW	NV400-CW, NV400-SW NV400-SEW, NV400-HEW NV630-CW, NV630-SW NV630-SEW, NV630-HEW NV800-SEW, NV800-HEW	For right pole (2, or 3 poles)	-	AX-4SW AX-4SWRS AX2-4SWRS	-	SHT-4SW SHT-4SWRS	-	
		For right pole (4 poles)	-	-	-	SHT-4SWRFS SHT-8SWRFS	-	
		For left pole (2, 3 or 4 poles)	AL-4SWL AL-4SWLS AL2-4SWLS	AX-4SW AX-4SWLS AX2-4SWLS	ALAX-4SWL ALAX-4SWLS	SHT-4SW SHT-4SWLS	-	
NF400-SWU, NF400-HWU NF630-SWU, NF630-HWU		For right pole	-	AX-4SWU AX-4SWURS AX2-4SWURS	-	SHT-4SWU SHT-4SWURS	-	
		For left pole	AL-4SWU	AX-4SWU	ALAX-4SWU	SHT-4SWU	-	

- Remarks:
- For the possibility of installation of accessories and the installation pole, refer to the tables of maximum numbers on pages 110 to 114.
  - AL and AX for minute load can be manufactured to order. (Please specify "B" at the end of the model.)
  - Corrosion-proof cassette type AL and AX are not available. When the circuit breaker body is exposed to class 1 tropicalization, class 2 tropicalization, reinforced corrosion resistance treatment or class 2 heat resistance treatment, place an order for the circuit breaker including the accessories.
  - Cassette type accessories with SLT for right pole cannot be installed to 4-pole circuit breakers. Accessories with SLT for right pole to be used in 4-pole circuit breakers are manufactured to order.
  - Cassette type accessories with SLT cannot be installed to flush plate type circuit breakers.
  - It is impossible to install a combination of a cassette type accessory with lead wires drawn out and that with SLT or a combination of cassette type accessories with SLT on the same pole.
  - It is impossible to install the cassette type AL or AX to the pole to which UVT has been installed.
  - AX and SHT with lead wires drawn out for frame size from 400 to 800A can be installed to any of the right and left poles.
  - When installing more than one AL or AX with lead wires drawn out for frame size from 400 to 800A to one side, install the necessary number of the accessories for one piece. The lead wires from the circuit breaker vary in length depending on the installation position.
  - Install the cassette accessories for frame size from 400 to 800A starting from the outside of the installation positions. For the installation positions, see the installation positions shown in the following table.
  - When three pieces of more of AL and AX are installed on a circuit breaker with a frame size 400 to 800A, the AL and AX with SLT are manufactured to order.

### Installation positions of cassette type accessories for 400 to 800A frames

#### Installation positions

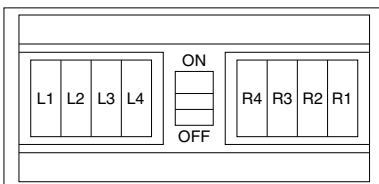

Table 6-11-2 Installation positions of cassette type accessories

Frame (A)	400 • 600 • 630					800							
	Installation positions					L1	L2	L3	L4	R4	R3	R2	R1
Accessory	L1	L2	L3	R2	R1	L1	L2	L3	L4	R4	R3	R2	R1
AL	○	○	-	-	-	○	○	○	-	-	-	-	-
AX	○	○	-	○	○	○	○	○	○	-	-	○ <sup>(*)</sup>	○
AL + AX	○	○	-	-	-	○	○	-	-	-	-	-	-
SHT	-	○	-	○	-	-	-	○	-	○ <sup>(*)</sup>	-	-	-

\* Accessories only for Earth Leakage Circuit Breakers (NV-C, S and H), Earth Leakage Alarm Breakers (NF-Z) and single-phase 3-wire circuits (NF-N and NV-N) cannot be installed to R1, R2, R3 or R4.

Note \*1 It is impossible to simultaneously install AX on R2 and SHT on R3 or R4.

Interpretation of type name

(1) Alarm switch • Auxiliary switch

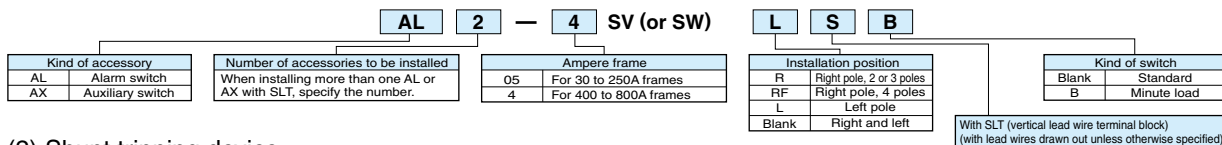

(2) Shunt tripping device

Undervoltage tripping device

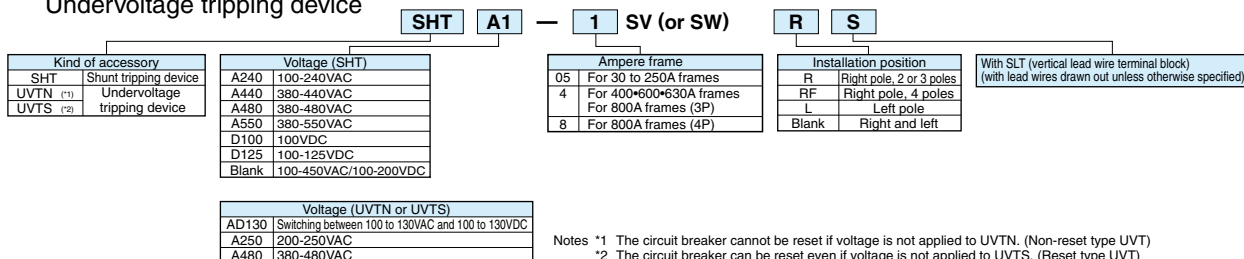

6. Shunt Trip (SHT)

Coil ratings (standard)

Table 6-12-1

Model	Provision of coil burnout preventing switch	Voltage (V)	Input (VA) (*1)		Operating time (ms) (*2)		
			AC	DC			
NF30-FAU NF50-FAU	Provided	100-120VAC 200-240VAC	120	—	20 or less		
NF50-FHU NF100-FHU		100-120VAC 200-240VAC 100VDC				50	15 or less
NF50-SVFU NV50-SVFU		100-240VAC 380-440VAC 100VDC				60	15 or less
NF32-SV, NF63-CV/SV/HV, NF125-SGV/LGV/HGV NF160-SGV/LGV/HGV, NF125-CV/SV/HV/SEV/HEV/RGV/UV NF250-CV/SV/HV/SEV/HEV/RGV/UV NF250-SGV/LGV/HGV NV32-SV, NV63-CV/SV/HV NV125-CV/SV/HV/SEV/HEV, NV250-CV/SV/HV/SEV/HEV NF100-CVFU, NF125-SVU/HVU, NF250-CVU/SVU/HVU NV100-CVFU, NV125-SVU/HVU, NV250-CVU/SVU/HVU		100-240VAC 380-550VAC 100-125VDC				50	
NF100-SRU/HRU (*3)	100-240VAC 380-480VAC 100-125VDC	100V 20 200V 50 380V 120 450V 170	100V 10 200V 35	5-15			
NF400-CW/SW/SEW/HEW/REW/UEW NF630-CW/SW/SEW/HEW/REW NF800-CEW/SDW/SEW/HEW/REW/UEW NV400-CW/SW/SEW/HEW NV630-CW/SW/SEW/HEW NV800-SEW/HEW, NF400-SWU/HWU, NF630-SWU/HWU	Not provided	100-110VAC, 110-127VAC 200-220VAC, 220-240VAC 24VDC, 100-110VDC	10	—	15 or less		
NF100-SRU/HRU NV100-SRU/HRU		100-120VAC 200-240VAC 380-450VAC 100VDC	200 300	70 100	7-15 15-25		
NF1000-SEW, NF1250-SEW/SDW NF1600-SEW/SDW	Provided	100-200VAC 100VDC	30	20	15 or less		
CP30-BA CP30-HU (*4)	Not provided	24-48VDC	—	20	15 or less		

Notes \*1 Ensure that the voltage of the operating power supply for SHT is not dropped below the allowable operating voltage (70% of the rated minimum voltage value) by the input power.  
\*2 The operating time is the time from when the rated voltage is applied to the shunt tripping device until the main contact of the circuit breaker starts opening.  
\*3 Available for right pole.  
\*4 The time rating is 10 seconds or less. Please ensure that the circuit configuration does not apply voltage for more than 10 seconds.

Remark: 1. The accessory is usable at 50 Hz and 60 Hz.

Coil ratings (list of available special voltage coils)

Table 6-12-2

Model	VAC										VDC										Compatible with AC/DC		
	24	25-27	24-48	48	50-55	60	440-480	380-550	440-550	500-550	12	24	24-36	36	36-48	48	60	110	125	220		200-250	220-250
NF32-SV, NF63-CV/SV/HV NF125-CV/SV/HV/SEV/HEV/RGV/UV NF125-SGV/LGV/HGV, F160-SGV/LGV/HGV NF250-CV/SV/HV/SEV/HEV/RGV/UV NF250-SGV/LGV/HGV NV32-SV, NV63-CV/SV/HV NV125-CV/SV/HV/SEV/HEV NV250-CV/SV/HV/SEV/HEV NF100-CVFU, NF125-SVU/HVU, NF250-CVU/SVU/HVU NV100-CVFU, NV125-SVU/HVU, NV250-CVU/SVU/HVU	-	-	○	-	-	-	-	-	-	○	-	○	-	○	-	-	-	-	-	-	○	-	-
NF100-SRU/HRU (*1)	-	-	○	-	-	○	-	-	-	○	-	○	-	○	-	○	-	-	-	-	-	○	-
NF400-CW/SW/SEW/HEW/REW/UEW NF630-CW/SW/SEW/HEW/REW NF800-CEW/SDW/SEW/HEW/REW/UEW NV400-CW/SW/SEW/HEW/REW NV630-CW/SW/SEW/HEW NV800-SEW/HEW, NF400-SWU/HWU, NF630-SWU/HWU	-	-	-	-	-	-	-	○	-	○	-	-	-	-	-	-	-	-	-	-	-	-	○
NF1000-SEW, NF1250-SEW/SDW NF1600-SEW/SDW	○	-	-	○	-	-	○	-	-	○	○	-	○	-	○	-	○	○	-	-	-	-	-

Notes \*1 Available for right pole.

## 7. Undervoltage Trip (UVT)

### (1) Specifications for UVT and coil ratings

Table 6-13

Model	Specification		Coil ratings			
	Reset type	Non-reset type	Voltage (V)		Input (VA)	Operating time (*2) (ms)
			Standard voltage	Special voltage (*1)		
NF50-SVFU NV50-SVFU	–	○	100-130VAC/DC 200-250VAC 380-480VAC	24VAC/DC 48VAC/DC	5	30 or less
NF32-SV, NF63-CV/SV/HV/HRV NF125-CV/SV/HV/RGV/SEV/HEV/UV NF125-SGV/LGV/HGV, NF160-SGV/LGV/HGV NF250-CV/SV/HV/RGV/SEV/HEV/UV NF250-SGV/LGV/HGV NV32-SV, NV63-CV/SV/HV NV125-CV/SV/HV/SEV/HEV NV250-CV/SV/HV/SEV/HEV NF100-CVFU, NF125-SVU/HVU, NF250-CVU/SVU/HVU NV100-CVFU, NV125-SVU/HVU, NV250-CVU/SVU/HVU	○	○		24VAC/DC 48VAC/DC 500-600VAC		
NF400-CW/SW/SEW/HEW/REW/UEW NF630-CW/SW/SEW/HEW/REW NF800-CEW/SDW/SEW/HEW/REW/UEW NV400-CW/SW/SEW/HEW NV630-CW/SW/SEW/HEW NV800-SEW/HEW	○ (*4)	○ (*5)	Switching between 100 to 110 and 120 to 130VAC Switching between 200 to 220 and 230 to 250VAC Switching between 380 to 415 and 440 to 480VAC Switching between 100 and 110VDC	Switching between 24/48VAC Switching between 500 to 550/600VAC Switching between 24/48VDC Switching between 110/125VDC	5	5-30
NF1000-SEW, NF1250-SEW NF1600-SEW	○	○				5-35
NF400-SWU/HWU, NF630-SWU/HWU	○ (*4)	–				5-30
NF100-SRU/HRU, NV100-SRU/HRU	–	○	100-110VAC 110-127VAC 200-220VAC 220-240VAC 24VDC 100-110VDC	–	10	30 or less

Notes \*1 Some special voltage models vary in voltage range.

\*2 The operating time is the time from when the undervoltage tripping device is set to the no-voltage state until the main contact starts opening.

\*3 The accessory is usable at 50Hz and 60Hz.

\*4 If UVT is turned on without excitation, the circuit breaker instantaneously opens and immediately trips.

\*5 Only for installation on the left pole

### (2) Reset type and non-reset type UVT

#### Reset type (Refer to Table 6-15.)

The reset type UVT has a structure which does not trip a circuit breaker even if the UVT coil is not excited when the circuit breaker handle is in the OFF or reset position. Therefore, it keeps the circuit breaker in the reset state even if the coil is not excited when the breaker is reset electrically.

When the coil in the unexcited state is turned on, the circuit breaker is normally tripped. However, the major contacts of some models of circuit breakers may instantaneously close, or, on circuit breakers with AX, the AX switches may instantaneously change over. For electrical interlock, use a non-reset type UVT.

#### Non-reset type (Refer to Table 6-15.)

When the UVT coil is not excited, the circuit breaker cannot be set to the off state even if the circuit breaker is tried to be reset from the tripped state. When the coil exciting voltage restores to the reference voltage or more, the circuit breaker can be reset to the off state.

### (3) Time delay UVT

- This type of UVT has a time delay in operation.
- It can prevent operation upon occurrence of instantaneous power failure.

Table 6-14

UVT module type name	Time delay	Voltage (V)	
		Standard voltage	Special voltage
U-05W	Switching among 0.1, 0.3 and 0.5s	24/48AC 100-120/200-240/380-450AC 220-250/380-450/460-550AC (Compatible with 50Hz and 60Hz)	380-450/460-550/600-690AC (Compatible with 50Hz and 60Hz) 24/48DC
		100-110DC	
U-30W	Switching among 0.5, 1 and 3s	100-120/200-240/380-450AC 220-250/380-450/460-550AC (Compatible with 50Hz and 60Hz)	–

Notes \*1 Available voltage ranges between 85% of the minimum rated voltage to 110% of the maximum rated voltage for each setting.  
(Ex.: In the case of 100 to 120V, a voltage range of 85 to 131V is available.)

\*2 The operating time denotes the time from when the UVT is set to the no-voltage state until the main contact of the breaker starts to open.

\*3 Operating time ranges for each setting are as shown below.  
0.1s setting: 0.1 to 0.3s, 0.3s setting: 0.3 to 0.5s, 0.5s setting: 0.5 to 1.0s, 1.0s setting: 1.0 to 3.0s, 3.0s setting: 3.0 to 6.0s

\*4 The maximum operating time is set by default.

\*5 This value is for the minimum voltage for each rated voltage. (Ex.: 85V or less in the case of 100 to 120V.)

\*6 This value is for the maximum voltage for each rated voltage. (Ex.: 42 to 84V in the case of 100 to 120V.)

Remark \*1 Contact us for details on applicable type names and ordering procedures.

### (4) Structure of UVT

The UVT mechanical unit is installed in a circuit breaker, and the UVT voltage module is installed on the outside of the circuit breaker. When the voltage drops, the UVT voltage module detects the voltage drop, and the UVT mechanical unit trips the circuit breaker.

The UVT voltage module has a vertical lead wire terminal block and is normally installed on the body. The external module will be manufactured to order.

#### ● Outline drawing

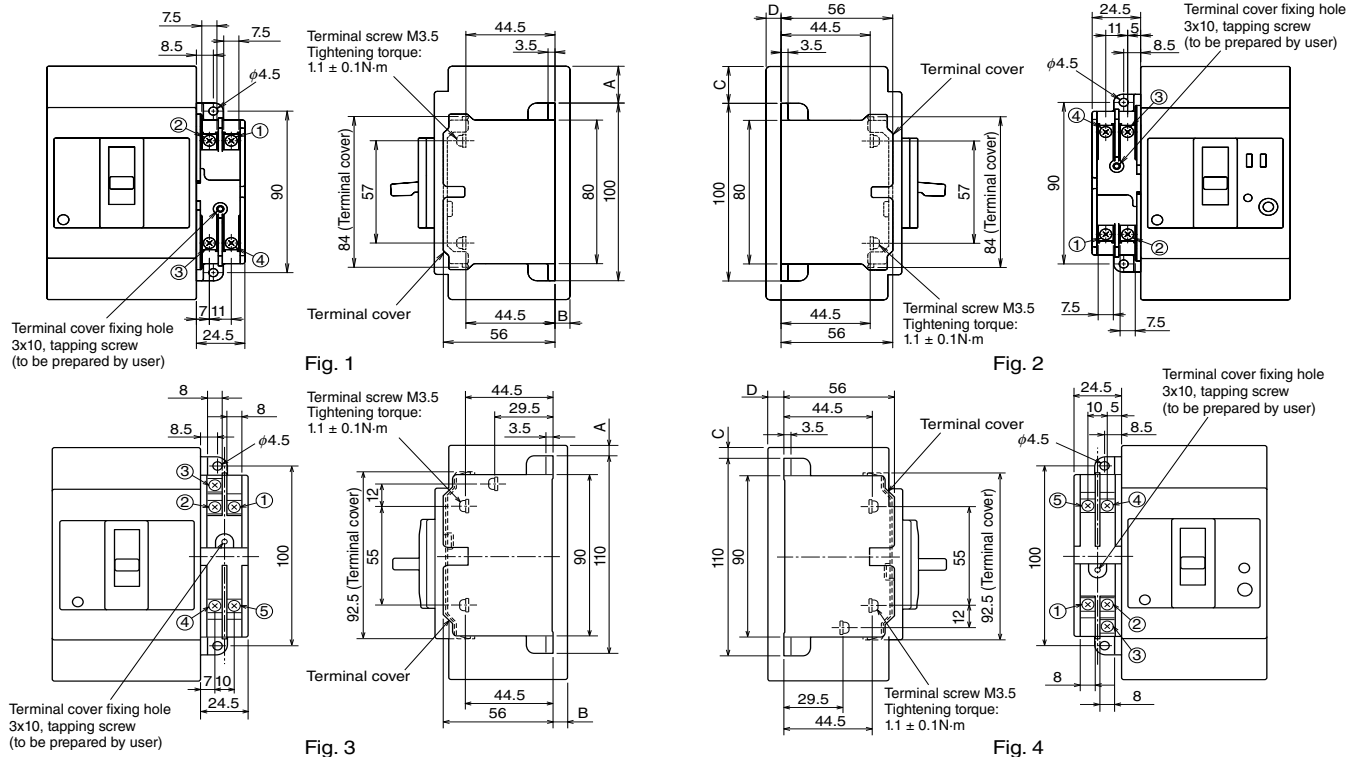

#### ● Examples of connection

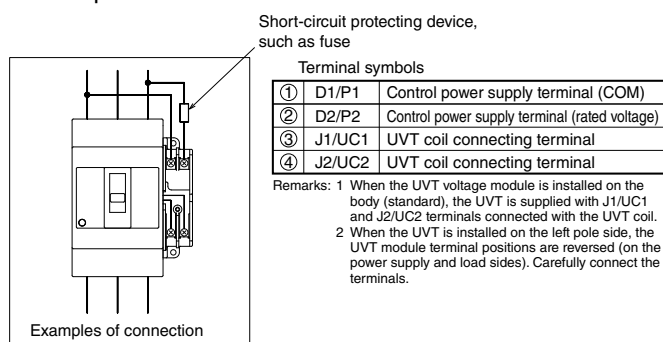

Fig. 5

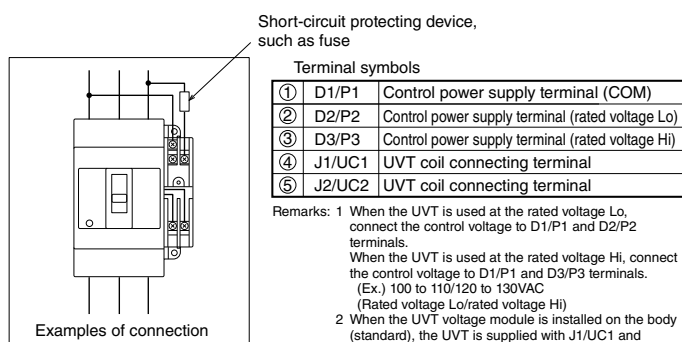

Fig. 6

Table 6-15 Installation on right pole side

Model	Reference drawing	Variable dimensions (mm)		
		A	B	
NF50-SVFU	Fig. 1 Fig. 5	11	7.5	
NF32-SV, NF63-CV/SV/HV		20.5	7.5	
NF100-CVFU		20.5	7.5	
NF125-CV/SV/HV		20.5	7.5	
NF125-SVU/HVU		41.5	7.5	
NF125-UV		81.5	7.5	
NF125-SEV/HEV/RGV, NF250-CV/SV/HV/RGV/SEV/HEV		Fig. 3 Fig. 6	38	7.5
NF125-SGV/LGV/HGV, NF160-SGV/LGV/HGV			48	7.5
NF250-SGV/LGV/HGV				
NF250-CVU/SVU/HVU				
NF250-UV	113	7.5		
NF400-CW/SW/SEW/HEW/REW	Fig. 3 Fig. 6	67.5	41.5	
NF630-CW/SW/SEW/HEW/REW, NF400-SWU/HWU		107.5	138.5	
NF400-UEW(3P)				
NF800-CEW/SDW/SEW/HEW/REW, NF630-SWU/HWU		76.5	41.5	
NF400-UEW(4P), NF800-UEW		123.5	138.5	
NF1000-SEW, NF1250-SEW, NF1600-SEW		161	63	

Table 6-16 Installation on left pole side

Model	Reference drawing	Variable dimensions (mm)		
		C	D	
NV50-SVFU	Fig. 2 Fig. 5	11	7.5	
NV32-SV, NV63-CV/SV/HV		20.5	7.5	
NV100-CVFU		30.5	7.5	
NV125-CV/SV/HV		20.5	7.5	
NV125-SVU/HVU		41.5	7.5	
NV125-SEV/HEV, NV250-CV/SV/HV/SEV/HEV		38	7.5	
NV250-CVU/SVU/HVU		48	7.5	
NF400-CW/SW/SEW/HEW/REW		Fig. 4 Fig. 6	67.5	41.5
NF630-CW/SW/SEW/HEW/REW				
NV400-CW/SW/SEW/HEW			107.5	138.5
NF400-ZCW/ZSW/ZEW				
NF400-SWU/HWU				
NF400-UEW(3P)	76.5		41.5	
NF800-CEW/SDW/SEW/HEW/REW	123.5		138.5	
NV800-SEW/HEW, NF630-SWU/HWU				
NF400-UEW(4P), NF800-UEW				

## 8. Lead Wire Drawing

### Lead wire lateral drawing ... Available to all models

Note \*1 Except for BH-D6, BH-D10, BH-DN, BV-D, BV-DN and KB-D.

Remark: 1. Although the following models are applicable to lead wires drawn laterally, they are normally applicable to installation in close contact with the circuit breaker side faces. (The circuit breaker side faces have grooves.)

### Specifications for lead wires

Table 6-17

Applicable model	Kind of lead wire	Lead wire thickness	Lead wire length	Example of ring mark										
1000A frame or above	Heat-resistant wire	0.75mm <sup>2</sup>	450mm	<table border="1"> <tr> <td>98/ALa (Red)</td> <td>96/ALB (Blue)</td> </tr> <tr> <td>95/ALC (Gray)</td> <td>14/AXa (Brown)</td> </tr> <tr> <td>12/AXB (Black)</td> <td>11/AXC (White)</td> </tr> <tr> <td>C1/S1 (Red)</td> <td>C2/S2 (Red)</td> </tr> <tr> <td>J1/UC1 (White)</td> <td>J2/UC2 (White)</td> </tr> </table>	98/ALa (Red)	96/ALB (Blue)	95/ALC (Gray)	14/AXa (Brown)	12/AXB (Black)	11/AXC (White)	C1/S1 (Red)	C2/S2 (Red)	J1/UC1 (White)	J2/UC2 (White)
98/ALa (Red)		96/ALB (Blue)												
95/ALC (Gray)	14/AXa (Brown)													
12/AXB (Black)	11/AXC (White)													
C1/S1 (Red)	C2/S2 (Red)													
J1/UC1 (White)	J2/UC2 (White)													
30 to 800A frames except above models	0.5mm <sup>2</sup>	<p>A terminal symbol is indicated on each lead wire with a ring mark.</p>												

NF32-SV, NF63-CV/SV/HV~NF250-CV/SV/HV/UV  
 NF125-SEV/HEV, NF250-SEV/HEV, NF125-RGV  
 NF250-RGV, NF125-SGV/LGV/HGV~NF250-SGV/LGV/HGV  
 NV32-SV, NV63-CV/SV/HV~NV250-CV/SV/HV  
 NV125-SEV/HEV, NV250-SEV/HEV  
 NF50-SVFU, NF100-CVFU, NF125-SVU/HVU,  
 NF250-CVU/SVU/HVU, NV100-CVFU, NV125-SVU/HVU  
 NV250-CVU/SVU/HVU

(When a 4-pole model among the above models has accessories installed on the right pole side, the lead wires are 400mm long.)

## 9. Lead Wire Terminal Block

### (1) Vertical lead wire terminal block (SLT)

The lead wire terminal blocks for plug-in terminal blocks are available (P-LT). The drilling size of these terminal blocks differs from the standard size. Consult us for details.

For a flush plate type circuit breaker, a terminal block will be installed on the circuit breaker rear face. (Specify as FP-LT.)

Note \*1 When the circuit breaker body is equipped with internal accessories and electrical operation device of motor-driven type (2) or spring charge type (2), the circuit breaker is normally provided with a lead wire terminal block.

### MCCB

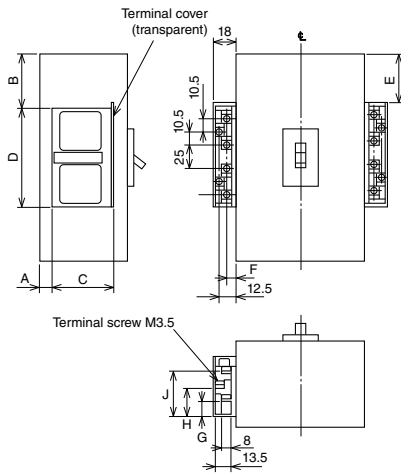

Table 6-18-1 Table of variable dimensions

(mm)

Model	A	B	C	D	E	F	G	H	J
NF30-FAU, NF50-FAU	(*1) 7	1.5	44.5	69	-	9	10.5	22.5	34.5
NF100-SRU	(*1) 16	16.5	44.5	86.5	16.5	6	10.5	22.5	34.5
NF100-HRU	(*1) 22	16.5	44.5	86.5	16.5	6	10.5	22.5	34.5
NF50-SVFU	16.5	17	44.5	86.5	17	6	10.5	22.5	34.5
NF32-SV, NF63-CV/SV/HV	7	26.5	54	86.5	26.5	7	14	26	38
NF63-HDV	7	26.5	54	86.5	26.5	7	14	26	38
NF100-CVFU	7	36.5	54	86.5	36.5	7	14	26	38
NF125-CV/SV/HV	7	26.5	54	86.5	26.5	7	14	26	38
NF125-SVU/HVU	7	47.5	54	86.5	47.5	7	14	26	38
NF125-UV	7	87.5	54	86.5	87.5	7	14	26	38
NF250-UV	7	119	54	86.5	119	7	14	26	38
NF125-SEV/HEV/HDVA	7	44	54	86.5	44	7	14	26	38
NF250-CV/SV/HV/SEV/HEV/HDVA	7	44	54	86.5	44	7	14	26	38
NF125-RV, NF250-RV	7	28.5	54	86.5	28.5	7	14	26	38
NF250-CVU/SVU/HVU	7	54	54	86.5	54	7	14	26	38
NF400-CW/SW/SEW/HEW/REW, NF400-SWU/HWU	41	79.5	54	86.5	79.5	7	14	26	38
NF630-CW/SW/SEW/HEW/REW									
NF800-CEW/SDW/SEW/HEW/REW, NF630-SWU/HWU	62.5	88.5	54	86.5	88.5	7	14	26	38
NF1000-SEW, NF1250-SEW/SDW, NF1600-SEW/SDW									
NF400-UEW(3P)	138	119.5	54	86.5	119.5	7	14	26	38
NF400-UEW(4P), NF800-UEW									
NF50-FHU	14	5	44.5	86.5	5	7	10	22	34
NF100-FHU	14	7	44.5	86.5	-4	7	10	22	34
NF400-HDW	47	79.5	54	86.5	79.5	7	14	26	38
NF800-HDW	47	88.5	54	86.5	88.5	7	14	26	38

Note \*1 The terminal positions are different from those shown in the left figure. Consult us for details.

Remark: 1. Terminal screw tightening torque: M3.5 ... 1.1 ± 0.1N·m

**ELCB**

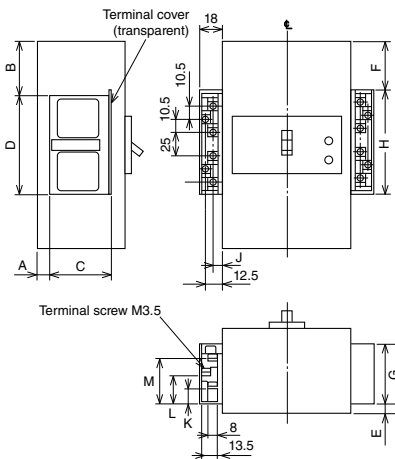

**Table 6-18-2 Table of variable dimensions**

(mm)

Model	A	B	C	D	E	F	G	H	J	K	L	M
NV30-FAU, NV50-FAU	7	1.5	44.5	69	-	-	-	-	9	10.5	22.5	34.5
NV100-SRU	16	16.5	44.5	86.5	-	-	-	-	6	10.5	22.5	34.5
NV100-HRU	22	16.5	44.5	86.5	-	-	-	-	6	10.5	22.5	34.5
NV50-SVFU	16.5	17	54	86.5	16.5	17	54	86.5	6	10.5	22.5	34.5
NV32-SV, NV63-CV/SV/HV	7	26.5	54	86.5	7	26.5	54	86.5	7	14	26	38
NV100-CVFU	7	36.5	54	86.5	7	36.5	54	86.5	7	14	26	38
NV125-CV/SV/HV	7	26.5	54	86.5	7	26.5	54	86.5	7	14	26	38
NV125-SVU/HVU	7	47.5	54	86.5	7	47.5	54	86.5	7	14	26	38
NV125-SEV/HEV, NV250-CV/SV/HV/SEV/HEV	7	44	54	86.5	7	44	54	86.5	7	14	26	38
NV250-CVU/SVU/HVU	7	54	54	86.5	7	54	54	86.5	7	14	26	38
NV400-CW/SW/SEW/HEW/REW	41	79.5	54	86.5	26.5	79.5	52	92	7	14	26	38
NV630-CW/SW/SEW/HEW, NV400-SWU/HWU	41	88.5	54	86.5	26.5	88.5	52	92	7	14	26	38
NV800-SEW/HEW	14	5	44.5	86.5	14	5	44.5	86.5	7	10	22	34
NV50-FHU	14	7	44.5	86.5	14	-4	44.5	86.5	7	10	22	34
NV100-FHU	14	7	44.5	86.5	14	-4	44.5	86.5	7	10	22	34

Notes \*1 The terminal positions are different from those shown in the left figure. Consult us for details.  
Remark : 1. Terminal screw tightening torque: M3.5 ... 1.1 ± 0.1N·m

**14-terminal SLT**

SLT for installing three or more internal accessories on the left pole side

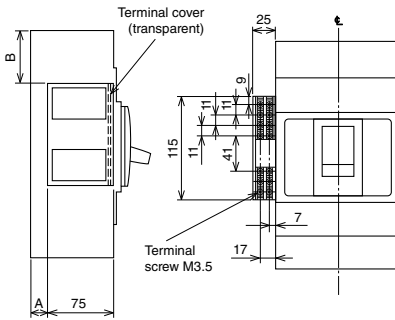

**Table 6-18-3 Table of variable dimensions**

(mm)

Model		A	B
MCCB	ELCB		
NF400-CW/SW/SEW NF400-HEW/REW NF630-CW/SW/SEW NF630-HEW/REW	NV400-CW/SW/SEW NV400-HEW NV630-CW/SW/SEW/HEW	20	60
NF400-UEW(3P) NF800-CEW/SDW/SEW NF800-HEW/REW	NV800-SEW/HEW	117	100
NF400-UEW(4P), NF800-UEW		20	69
NF1000-SEW, NF1250-SEW		117	116
NF1600-SEW		35	154

Remarks : 1. The terminal positions are different from those shown in the left figure. Consult us for details.  
2. Terminal screw tightening torque: M3.5 ... 1.1 ± 0.1N·m

**10. Test Button Module (TBM)**

- The test button is kept pressed while control input voltage is applied to the button. (When ELCB of time delay type is used, apply voltage for 2 seconds or more.)
- The test button module is supplied with voltage through a circuit isolated from the main circuit. It can share the control sequence with SHT of a molded case circuit breaker.
- The test button modules can be connected in parallel.
- The module is normally provided with a vertical lead wire terminal block (SLT).

**Table 6-19**

Model	NV32-SV NV63-CV/SV/HV NV125-CV/SV/HV NV125-SEV/HEV NV250-CV/SV/HV/SEV/HEV NV50-SVFU NV100-CVFU NV125-SVU/HVU NV250-CVU/SVU/HVU	NV400-CW/SW NV630-CW/SW NV400-SEW-NV800-SEW NV400-HEW-NV800-HEW
Control input	Compatible with 100 to 240AC and 100 to 240DC	
Rated voltage (V)	(24DC) (*1)	
Control input (VA)	1.5VA or less	1VA or less
Reference drawing	Fig. 1	Fig. 2

Note \*1 Unless otherwise specified, the module will be manufactured for 100 to 240VAC and 100 to 240VDC.  
In the case of 24VDC, specify the voltage.

Remark: 1. The length of the lead wires to be connected to TBM1 and 2 shall be 100 mm or less.

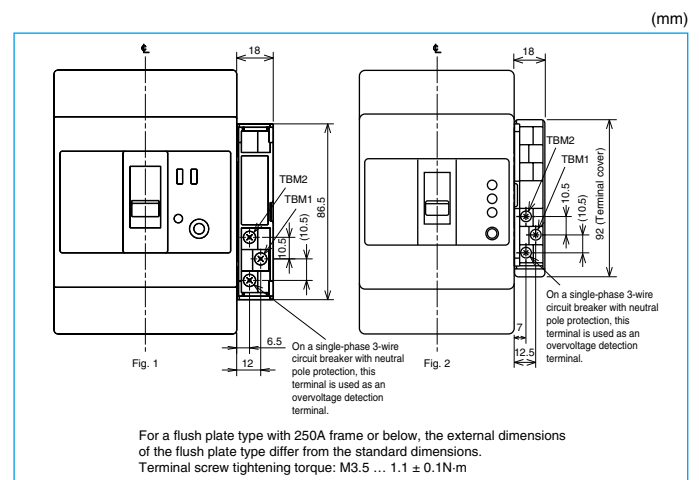

(mm)

For a flush plate type with 250A frame or below, the external dimensions of the flush plate type differ from the standard dimensions.  
Terminal screw tightening torque: M3.5 ... 1.1 ± 0.1N·m

## 11. Pre-Alarm Module (PAL)

The pre-alarm is a function to output an alarm when the load current exceeds the preset current value. It is helpful in securing continuous power supply and preventive maintenance.

It can be fitted to electronic circuit breakers with a frame size from 125 to 1600A.

### ■ 125 and 250A frames

#### ● Pre-alarm module (PAL module)

The standard modules have SLT. Other internal accessories cannot be installed on the right pole side.

A control power supply (compatible with 100 to 240VAC and DC) is necessary. The control power supply voltage range is 85 to 246VAC/DC, and the required volt-ampere is 5VA.

Table 6-20-1

Model	Switching capacity	Contact output (1a)	Resetting method
NF125-SEV NF125-HEV NF250-SEV NF250-HEV NV125-SEV NV125-HEV NV250-SEV NV250-HEV	125VAC 2A 250VAC 2A	30VDC 2A 100VDC 0.3A	Press the reset button, or turn off the control power supply.

### Pre-alarm characteristics

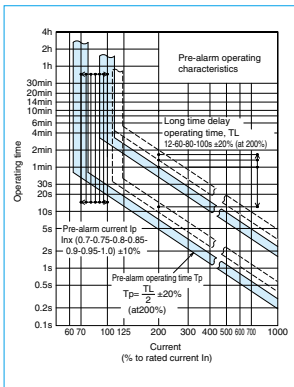

### Dimensional drawing of pre-alarm module

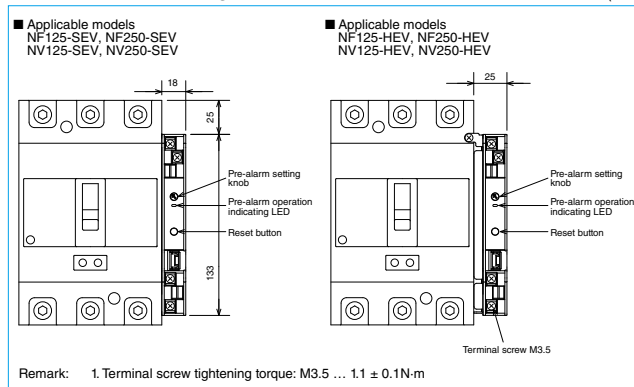

### Terminal arrangement

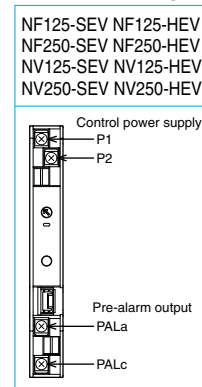

### ● Pre-alarm LED indication

When the load current exceeds the preset current value, the LED lamp on the pre-alarm module front panel starts blinking. When the pre-alarm output is given, the lamp stops blinking and turns on.

### ● Pre-alarm current setting ( $I_p$ setting)

The pre-alarm current can be set to the rated current  $I_n \times 0.7-0.75-0.8-0.85-0.9-0.95-1.0$  with the knob on the pre-alarm module front panel.

### ■ 400A frame or above

#### ● Solid state relay (SSR) output (PAL lead)

The lead wires are drawn out. On the right pole side, only internal accessories with lead wires drawn out can be installed. A control power supply is unnecessary.

Table 6-20-2

Model	Switching capacity	Resetting method
NF400-SEV NF400-HEV NF400-REW NF400-UEW NF630-SEV NF630-HEV NF630-REW NF800-CEW NF800-SEW NF800-HEW NF800-REW NF800-UEW NF1000-SEW NF1250-SEW NF1600-SEW NV400-SEV NV400-HEV NV630-SEV NV630-HEV NV800-SEV NV800-HEV	Solid state relay (SSR) – Non-contact output 24 to 240VAC/DC 20mA	When the load current becomes lower than the preset current value, the alarm is reset.

### ● Pre-alarm module (PAL module)

The standard modules have SLT. Other internal accessories cannot be installed on the right pole side.

A control power supply (compatible with 100 to 200VAC) is necessary. The control power supply voltage range is 80 to 242VAC, and the required volt-ampere is 10VA.

Table 6-20-3

Model	Switching capacity	Contact output (1a)	Resetting method
NF400-SEV NF400-HEV NF400-REW NF400-UEW NF630-SEV NF630-HEV NF630-REW NF800-CEW NF800-SEW NF800-HEW NF800-REW NF800-UEW NF1000-SEV NF1250-SEV NF1600-SEW NV400-SEV NV400-HEV NV630-SEV NV630-HEV NV800-SEV NV800-HEV	100VAC or 200VAC, 2A		Press the reset button, or turn off the control power supply.

### Pre-alarm characteristics

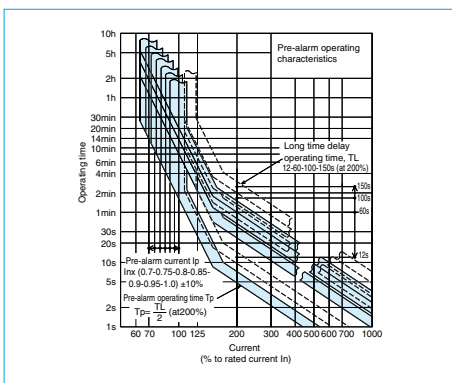

### Detailed drawing of pre-alarm module

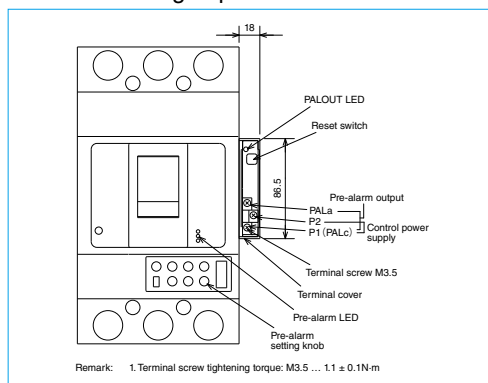

### Pre-alarm module output rating

Voltage (V)	Current (A)	
	Resistive load	Inductive load
200	3	2
100	3	2

A control power supply (compatible with 100 to 200VAC) is necessary. For the wiring method, see the following figure. (The control power supply voltage range is 80 to 242VAC.) The required volt-ampere is 10VA.

### ● Pre-alarm LED display (standard device)

When the load current exceeds the preset current value, the LED lamp on the circuit breaker front panel starts blinking. When the pre-alarm output is given, the lamp stops blinking and turns on at PALOUT LED.

### ● Pre-alarm current setting ( $I_p$ setting)

The pre-alarm current can be set to the rated current  $I_n \times 0.7-0.75-0.8-0.85-0.9-0.95-1.0$  with the knob on the circuit breaker front panel.

## 1. F-Type Operating Handle Operating handle of breaker mount type to be installed to circuit breaker body

### ● Appearance (Color: Munsell N1.5)



- The handle provides an isolating function in combination with the circuit breaker body (except F10SW and above).
- It has a safety device which prevents the circuit breaker turning on while the door is open.
- It can be locked in the OFF position. (Up to 3 commercially available padlocks (35mm and 40mm) can be fitted. A type which can be locked in the ON or OFF position can be manufactured. Specify the type if required.) On circuit breakers with a frame size of 1000A or above, the handle can be locked in the ON or OFF position. (If it is necessary to lock the handle only in the OFF position, specify so.)
- It is in protection class IP54 (IEC 60529). (For circuit breakers with a frame size of 1000A or above, the protection class (IEC 60529) is IP3X (IP5X when dust-proof packing is provided).)

### Dust-proof packing (optional)

Type name	Operating handle type name	Delivery category
PFL	F10SW-F120UR	●

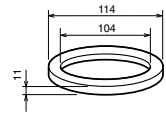

### ● Outline drawings

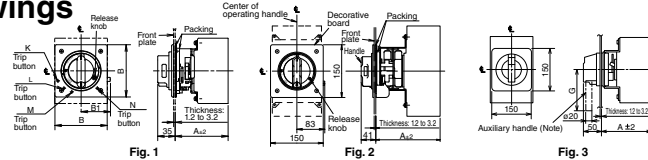

Note Auxiliary handles are provided with F10SW, F10SW4P and F120UR as standard. Auxiliary handles (F-HT) are provided for F-4S - F-6SUL as option.

### ● Center of hinge and breaker

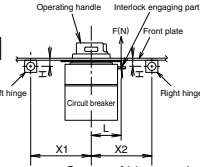

- The left drawing shows the relationship between the hinges and circuit breaker viewed from the load side of the circuit breaker.

### ● Dimensional drawings of front plate drilling

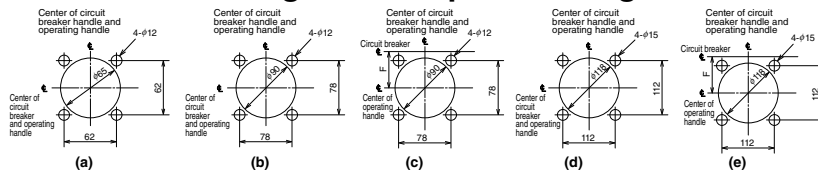

### ● Dimensional drawings of circuit breaker mounting holes

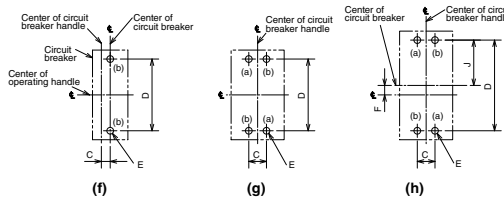

	Hinge on left side		Hinge on right side	
	H	X <sub>1</sub>	H	X <sub>2</sub>
For 30 to 250A frames	0 or more	(5H+85) or more	Less than 10	170 or more (5H+120) or more
For 400 to 800A frames	0 or more	(5H+85) or more	0 or more	(4H+120) or more
For 1000 to 1600A frames	0 or more	(8H+150) or more	0 or more	(4H+120) or more

- Remarks: 1. The handle is opened and closed in the projection area of the handle and does not run over the projection area of the circuit breaker (except when the auxiliary handle is provided).  
2. When the operating handle is fitted to NV, the test button cannot be pressed easily. If necessary, use a circuit breaker with TBL or TBM. When using an Earth Leakage Alarm Breaker, use the externally resetting type (ECA-SLT RST) or automatically resetting type (ARS).

### ● Door lock withstand load

	F(N)	L(mm)
F-05-F-2	500	50
F-4-F-8		68

Table 6-21 Table of variable dimensions

Type name	Door opening position		Applicable model				Reference drawing		Dimensions (mm)											Mounting screw
	OFF position	Reset position	MCCB	Number of poles	ELCB	Number of poles	Dimensional drawing	Drilling plan	A (*1)	B	B1	C	D	E	F	G	J	Trip button position (*4)		
F-05SV2	-	○	NF32-SV	2P	-	-	Fig. 1	f	105	104	58	13	111	-	-	-	-	N		
F-05SVE2	-	○	NF63-CV, NF63-SV, NF63-HV	3P • 4P	NV32-SV	2P • 3P		g	25			L								
F-05SV	-	○	NF32-SV	3P • 4P	NV63-CV, NV63-SV, NV63-HV	2P • 3P		f	15			N								
F-05SVE (*2)	-	○	NF63-CV, NF63-SV, NF63-HV	2P	-	-		g	30			L								
F-1SV2, F-1SVE2	-	○	NF125-CV, NF125-SV	2P	-	-		h	172			L								
F-1SV	-	○	NF125-CV, NF125-SV	3P • 4P	NV125-CV, NV125-SV, NV125-HV	3P • 4P		c	31			86							L	
F-1SVE	-	○	NF125-HV	2P • 3P • 4P	-	-		-	-			-							-	
F-1UV, F-1UVE	-	○	NF125-UV	2P • 3P • 4P	-	-		-	-			-							-	
F-2SV	-	○	NF125-SEV, NF125-HEV, NF125-RV	2P • 3P • 4P	NV125-SEV, NV125-HEV	3P • 4P		b	35			126							K	
F-2SVE	-	○	NF125-SGV, NF125-LGV, NF125-HGV	2P • 3P • 4P	NV250-CV, NV250-SV, NV250-HV	3P • 4P		f	201			-							-	
F-2UV, V-2UVE	-	○	NF250-UV	2P • 3P • 4P	-	-	c	30	123	100.5	L									
F-1SVUL	-	○	NF125-SVU, NF125-HVU	3P	NV125-SVU, NV125-HVU	3P	c	35	126	61.5	K									
F-2SVUL	-	○	NF250-CVU, NF250-SVU, NF250-HVU	3P	NV250-CVU, NV250-SVU, NV250-HVU	3P	g	0	92	-	-									
F-05SRUL2	-	○	NF100-SRU	2P	NV100-SRU	2P	b	110	25	-	-									
F-05SRUL	-	○	NF100-HRU	3P	NV100-SRU	3P	g	116	9	82.5	M4 screw or φ5									
F-03SVUL2	-	○	NF50-SVFU	2P	NV50-SVFU	2P	a	80	50	18		M6 screw or φ7								
F-03SVUL	-	○	NF100-CVFU	3P	-	3P	g	105	13	111			23.5							
F-05SVUL2	-	○	NF100-CVFU	2P	-	-	b	104	58	25			-							
F-05SVUL	-	○	NF100-CVFU	3P	NV100-CVFU	3P	g	104	58	25	-									
F-4S	-	○	NF400-CW, SW, SEW, HEW, REW	2P, 3P, 4P	NV400-CW, SW, SEW, HEW	3P, 4P	d	183	44	194	M6 screw or φ7									
F-4SE	-	○	NF630-CW, SW, SEW, HEW, REW	3P, 4P	NV630-CW, SW, SEW, HEW	3P, 4P	g	183	234	20										
F-4U	-	○	NF400-UW	3P	-	-	e	280	243	-										
F-4UE	-	○	NF400-UW	3P	-	-	h	280	290	-										
F-8S	-	○	NF800-CEW, SDW, SEW	2P, 3P, 4P	NV800-SEW, HEW	3P	d	183	70	243	M8 screw or φ10									
F-8SE	-	○	NF800-HEW, REW	2P, 3P, 4P	NV800-SEW, HEW	3P	g	183	70	243										
F-8U	-	○	NF800-UW	3P, 4P	-	-	e	280	44	194										
F-8UE	-	○	NF800-UW	3P, 4P	-	-	h	280	70	243										
F-4SUL	-	○	NF400-SWU/HWU	3P	-	-	d	183	44	194	M8 screw or φ10									
F-6SUL	-	○	NF630-SWU/HWU	3P	-	-	g	183	70	243										
F10SW (*3)	-	○	NF1000-SEW	2P, 3P	-	-	d	221	-	-	70	375	-	200	-	-	-	(a)(b) Circuit breaker mounting screw (4 pcs.)		
F10SW4P (*3)	-	○	NF1250-SEW/SDW	4P	-	-	g	221	-	-	70	375	-	200	-	-	-	(a)(b) Circuit breaker mounting screw (4 pcs.)		

- Notes \*1 The dimensions for the front connection type are shown. On some models of the rear connection type and plug-in type, the reference surface for mounting the circuit breaker may change.  
\*2 For the 4-pole plug-in type, a special handle is required. Consult us for details.  
\*3 If a handle which can be locked only in the OFF position is required, specify so.  
\*4 The circuit breaker can be tripped by operating the trip button while the door is open.  
\*5 Do not remove the sponge packing used to secure the protection class IP51. Fit the supplied packing without fail.  
\*6 The handle cannot be used when the circuit breaker is installed on IEC 35mm rails.

- Remarks: 1. The handles with E in their model names are designed for emergency stop devices.  
2. The standard handles are Reset Open Type which can open the doors only when they are reset to open. OFF Open type handles which can open the doors when they are in the OFF position can be manufactured to order.  
3. A handle which can be operated and can indicate the ON and OFF positions in the same manner as the standard models even if the circuit breaker is installed horizontally can be manufactured to order.  
4. F10SW and higher models do not conform to the isolation function.  
5. Handles which are opened and closed in the OFF position can be opened also in the reset position.

## ● Installation procedure For details, please refer to Operating Handle Installation Manual supplied with the product.

### ① Installation to a breaker Install the operating handle to the circuit breaker in accordance with the following procedure.

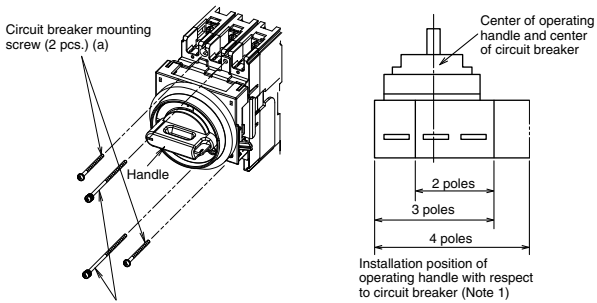
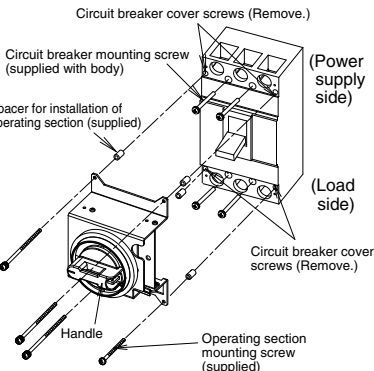
	250A frame and below		400 to 1600A frames
Installation procedure	 <p style="text-align: center;">Center of operating handle and center of circuit breaker</p> <p style="text-align: center;">Installation position of operating handle with respect to circuit breaker (Note 1)</p> <p style="text-align: center;">(In the case of F-05SV2, F-1SV2, F-05SRUL2, F-05SUL2 and F-1SUL2)</p> <p>Tighten the circuit breaker and operating handle together with the supplied two operating handle mounting screws.</p>		<p style="text-align: center;">Circuit breaker cover screws (Remove.)</p>  <p style="text-align: center;">(In the case of F-4S to F-6SUL) The operating handle mounting screws are tapping screws without washers or spring washers.</p>
	<p style="text-align: center;">(Installation procedure)</p> <ol style="list-style-type: none"> <li>① Install the circuit breaker on the panel with the two circuit breaker mounting screws through the holes (a).</li> <li>② Install the operating handle with the supplied two operating handle mounting screws through the holes (b).</li> </ol>		<p style="text-align: center;">(Installation procedure)</p> <ol style="list-style-type: none"> <li>① Remove the circuit breaker cover screws in the same positions as the operating handle mounting holes.</li> <li>② Install the circuit breaker with the four circuit breaker mounting screws.</li> <li>③ Fit the spacer(s) for installation of operating handle between the circuit breaker and operating handle. (The number of the spacers varies depending on the model.)</li> <li>④ Install the operating handle with the supplied operating handle mounting screws.</li> </ol>

Note \*1 In the case of F-05SRUL2, the center of the operating handle is the same as the center of the circuit breaker.

### ② Installation of decorative board and retaining board

Drill holes in the door according to the drilling size shown on the previous page, and tighten the decorative board and retaining board with the supplied countersunk screws. In the case of 800A frame or below, fit the supplied packing to the position shown right.

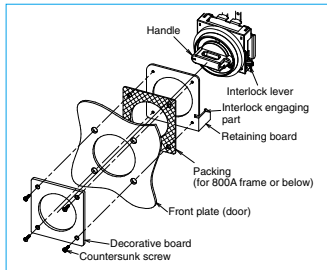

### ● Door locking mechanism

The panel door can be opened only when the operating handle is operated to open (reset). (On F-4S to F10SW, the door lock is held in the released state even if the handle is returned to OFF.) The door can be opened when the handle is in the ON position if the release knob is operated with a tool.

### ● Operation locking mechanism

Circuit breakers with a frame size of 800A or below can be locked by setting the handle in the OFF position. (Operating handles which can lock circuit breakers in the ON or OFF position can be manufactured.) Operate the locking part, and lock the handle with padlocks. Up to three padlocks can be fitted.

Lockout hasps (scissors locks) can be used.

If the circuit breaker trips even when the operating handle is locked in the ON position, also the operating handle indicates that it has tripped.

[ F-2SUL or below: Only when one 35mm padlock (weighing 70g or less) is used ]  
 [ F-4S or above: Only when one 40mm padlock (weighing 100g or less) is used ]

To 800A frame or below, padlocks with dimension B of 3mm to 8mm can be applied.

For 1000A or above, padlocks with dimension of 3mm to 6mm can be applied. (When using padlocks of 3mm or less, please consult us.)

### ● Circuit breaker installation direction (except UL 489 listed circuit breakers)

We can supply circuit breakers on which the handles and their ON and OFF positions are in the same directions as on vertically installed circuit breakers even when they are installed horizontally. The door drilling size is identical. If you intend to install an operating handle on a horizontally installed circuit breaker, specify "Y" (horizontal installation with power supply on the left) or "Z" (horizontal installation with power supply on the right) at the end of the model name. (Ex.: F-4S Y)

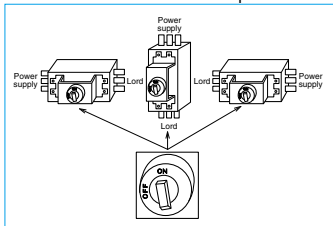

### ● Sealing of release knob

The use of an optional part, Release Protection "F-RCS", can prevent the panel door being opened by operating the release knob. (800A frame or below)

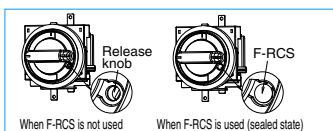

### ● Operation Lock Devices

#### (1) Padlock



**Padlock Dimensions**

Use commercially available padlocks. (mm)

Applicable model	A (Nominal size)	B
All models	35	5
	40	6.5 or less

Dimension B: Maximum 8mm.

#### (2) Lockout Devices (Scissors Lock)

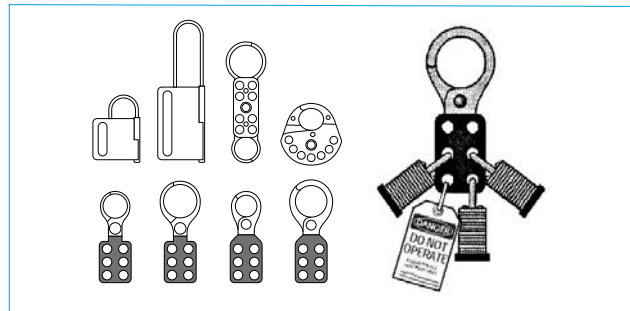

### ● How to order

For 800A frame or below, specify the following specification symbols together with the model name.

- Operation lock: LF ..... Lock in OFF position
- Operation lock: LN ..... Lock in ON or OFF position
- Door opening: DR ..... Reset to open
- Operation lock: DF ..... Open in OFF position
- Installation direction: Blank ... Power supply upward
- Installation direction: Y ..... Power supply on left
- Operation lock: Z ..... Power supply on right

For a standard product with a frame size of 1000A or above, specify the model name. When it is required to enable the operation lock only in the OFF position, specify the model name and "only lock in OFF position."

If you intend to seal the release knob, place an order for the release protection. (Lot: 10 pcs.)

### ● Interpretation of model name

(1) For 800A frame or below

$$\frac{F}{1)} - \frac{1}{2)} \frac{SV}{3)} \frac{UL}{4)} \frac{E}{5)} \frac{2}{6)}$$

- 1) F: Operating handle type name
- 2) 1: Circuit breaker group (0.5, 1, 2, 4, 6 or 8)
- 3) SV: Classification of circuit breaker (S, SV, H, U, UV, SR or SG)
- 4) UL: Blank...General product UL...UL 489 listed product
- 5) E: Blank...Standard E...For emergency stop
- 6) 2: Blank...3P or 4P 2...2P

(2) For 1000A frame or above

$$\frac{F}{1)} \frac{10}{2)} \frac{SW}{3)} \frac{4P}{4)}$$

- 1) F: Operating handle type name
- 2) 4: Circuit breaker A frame (10 or 120)
- 3) SW: Series name
- 4) 4P: Number of poles (4P) \* Not indicated for 3P

## 2. V-Type Operating Handle

### ● Appearance (Color: Munsell N1.5)



Operating handle of door mount type consisting of operating section to be mounted on circuit breaker body and operating handle on panel door

- The handle provides an isolation function in combination with the circuit breaker body.
- Conforming to the safety regulations of EN Standard (EN 60204-1)
- Protection class (IEC 60529) IP65 as standard
- The handle can be locked only in the OFF position with up to three commercially available padlocks (35mm or 40mm).
- The panel door can be opened in the OFF position. In the ON and trip positions, the panel door is locked and cannot be opened. However, the door can be opened even in the ON and trip positions by operating the release part with a tool.

### ● Outline drawings

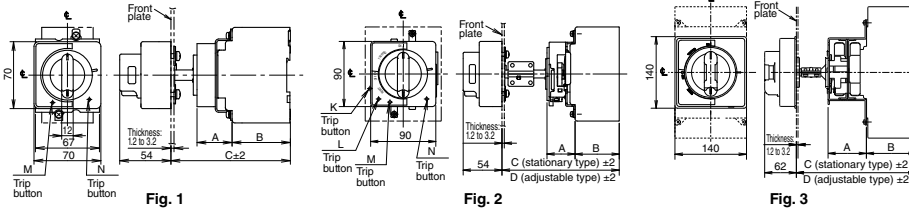

### ● Center of hinge and breaker

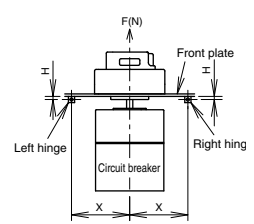

Relationship between hinges and circuit breaker viewed from load side of circuit breaker

### ● Dimensional drawings for front plate drilling

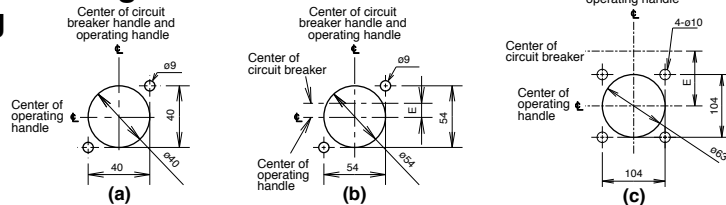

	H	X
For 30 to 250A frames	0 or more	5H+100 or more
For 400 to 800A frames		8H+150 or more

\* The above figure shows the relationship viewed from the load side.

### ● Dimensional drawings of circuit breaker mounting holes

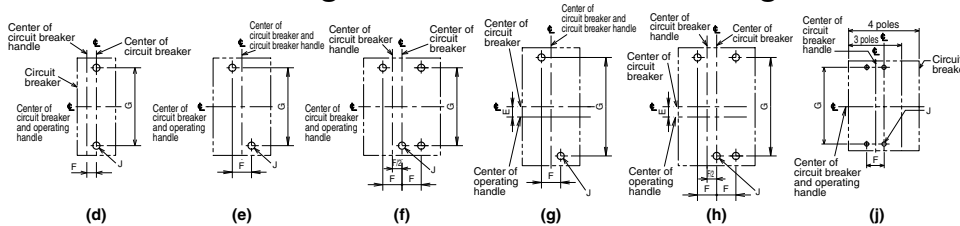

### ● Door lock withstand load

	F(N)
30 to 800A frames	200

Table 6-22 Table of variable dimensions

Type name		Applicable model				Reference drawing	Dimensions (mm)																																																																																																																																
Stationary type	Adjustable type	MCCB		ELCB		Dimensional drawing	Drilling plan	A	B	Stationary type C	Adjustable type(*2)		E	F	G	J	Trip button position (*5)																																																																																																																						
			Number of poles		Number of poles						D (min)	D (max)																																																																																																																											
V-05SV2 V-05SVE2	Adjusting unit V-AD3S is mounted on stationary type.	NF32-SV	2P	-	-	Fig. 2	d	61	125	-	-	-	12.5	-	-	-	N																																																																																																																						
V-05SV V-05SVE		NF63-SV, NF63-CV, NF63-SV, NF63-HV	3P	NV32-SV	2P, 3P		e										162	300	25	L																																																																																																																			
V-1SV2, V-1SVE2		NF125-SV, NF125-CV, NF125-SV	2P	-	-		d										39	-	-	15	111	-	-	-	-	-	N																																																																																																												
V-1SV V-1SVE		NF125-SV, NF125-CV, NF125-SV	3P	NV125-SV, NV125-CV, NV125-HV	3P		e																				61	125	-	-	-	-	-	-	-	-	-																																																																																																		
V-1UV V-1UVE		NF125-SV, NF125-CV, NF125-SV	4P	-	-		f																															39	-	-	-	-	-	-	-	-	-	-																																																																																							
V-2SV V-2SVE		NF125-SV, NF125-CV, NF125-SV	2P, 3P	NV125-SV, NV125-CV, NV125-HV	3P		e																																										41	-	-	-	-	-	-	-	-	-	-																																																																												
V-2UV V-2UVE		NF125-SV, NF125-CV, NF125-SV	4P	-	-		f																																																					61	130	-	-	-	-	-	-	-	-	-																																																																	
V-03SVUL2 V-03SVUL		NF50-SV, NF50-SV, NF50-SV	2P	NV50-SV, NV50-SV	2P		g																																																																37	61	125	-	-	-	9	82.5	-	-	-	M																																																					
V-05SVUL2 V-05SVUL		NF100-SV, NF100-SV, NF100-SV	3P	-	-		h																																																																											39	61	125	-	-	-	12.5	111	-	-	-	N																																										
V-1SVUL V-2SVUL		NF125-SV, NF125-CV, NF125-SV	3P	NV125-SV, NV125-CV, NV125-HV	3P		e																																																																																						39	61	125	162	300	6	30	123	-	-	-	L																															
V-05SRUL2 V-05SRUL		NF250-SV, NF250-CV, NF250-SV	3P	NV250-SV, NV250-CV, NV250-HV	3P		f																																																																																																	41	61	125	-	-	-	-	-	-	-	-	K																				
V-4S V-4SE V-4U V-4UE V-8S V-8SE V-4SUL V-6SUL		NF100-SV, NF100-SV, NF100-SV	2P	-	-		g																																																																																																												44	61	130	-	-	-	-	-	-	-	-	-									
V-4S V-4SE V-4U V-4UE V-8S V-8SE V-4SUL V-6SUL	NF100-SV, NF100-SV, NF100-SV	3P	NV100-SV, NV100-SV, NV100-SV	3P	h	61	130	167	305	-	-	-	-	-	-	-																																																																																																															-								
V-4S V-4SE V-4U V-4UE V-8S V-8SE V-4SUL V-6SUL	NF100-SV, NF100-SV, NF100-SV	4P	-	-	e																																																																																																																											67	136	173	311	-	-	-	-
V-4S V-4SE V-4U V-4UE V-8S V-8SE V-4SUL V-6SUL	NF100-SV, NF100-SV, NF100-SV	3P	NV100-SV, NV100-SV, NV100-SV	3P	j												76	97	191	233	300	-	-	-	-	-																																																																																																													
V-4S V-4SE V-4U V-4UE V-8S V-8SE V-4SUL V-6SUL	NF100-SV, NF100-SV, NF100-SV	4P	-	-	h																						97	191	233	300	-	-	-	-	-	-	-																																																																																																		
V-4S V-4SE V-4U V-4UE V-8S V-8SE V-4SUL V-6SUL	NF100-SV, NF100-SV, NF100-SV	2P, 3P, 4P	NV100-SV, NV100-SV, NV100-SV	3P, 4P	j																																	97	191	233	300	-	-	-	-	-	-	-																																																																																							
V-4S V-4SE V-4U V-4UE V-8S V-8SE V-4SUL V-6SUL	NF100-SV, NF100-SV, NF100-SV	3P	-	-	h																																												97	191	233	300	-	-	-	-	-	-	-																																																																												
V-4S V-4SE V-4U V-4UE V-8S V-8SE V-4SUL V-6SUL	NF100-SV, NF100-SV, NF100-SV	3P	-	-	j																																																							97	191	233	300	-	-	-	-	-	-	-																																																																	
V-4S V-4SE V-4U V-4UE V-8S V-8SE V-4SUL V-6SUL	NF100-SV, NF100-SV, NF100-SV	3P	-	-	j																																																																		97	191	233	300	-	-	-	-	-	-	-																																																						

Notes \*1 For the adjustable type, purchase the optional adjusting unit V-AD3S or V-AD3L.  
\*2 The dimensions of the adjustable type models provided with the adjusting unit V-AD3S or V-AD3L are shown.  
\*3 When using the operating handle for a plug-in type model with a frame size of 250A or below, specify so.  
\*4 The dimensions on the front connection type are shown. For the rear connection and plug-in types, separately consult us.  
\*5 The circuit breaker can be tripped by operating the trip button while the door is open. (The trip button position varies depending on the model.)  
\*6 The handle cannot be used when the circuit breaker is installed on IEC 35mm rails.

Remarks 1. The products whose model names contain E are designed for emergency stop.  
2. When the operating handle is fitted to NV, the test button cannot be pressed easily. If necessary, use a circuit breaker with TBL or TBM. When using an Earth Leakage Alarm Breaker, use the externally resetting type (ECA-SLT) or automatically resetting type (ARS).

## ● Installation procedure For details, please refer to Operating Handle Installation Manual supplied with the product.

### ① Installation to a breaker Install the operating handle to the circuit breaker in accordance with the following procedure.

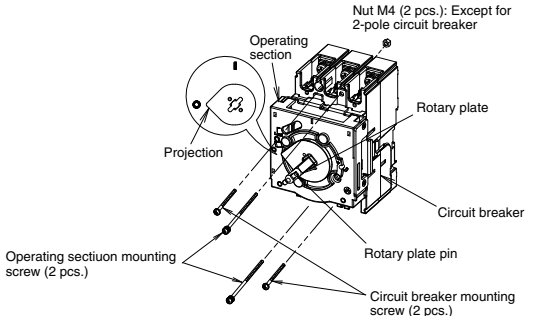
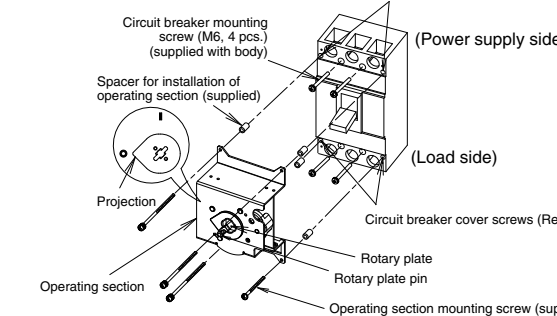
	250A frame and below	400 to 800A frames
Installation procedure	<p><b>(Installation procedure)</b></p> <p>① Operating handle for 3- or 4-pole circuit breaker Set the rotary plate of the operating section to the OFF (symbol O) position, and fit the plate to the circuit breaker with the supplied operating section mounting screws and nuts. Install the circuit breaker to the panel with the circuit breaker mounting screws (2 pcs.).</p> <p>② Operating handle for 2-pole circuit breaker Install the operating section together with the circuit breaker to the panel with the supplied operating section mounting screws (2 pcs.).</p> 	<p><b>(Installation procedure)</b></p> <p>① Remove the circuit breaker cover screws (4 pcs.) in the same positions as the operating handle mounting holes.</p> <p>② Install the circuit breaker with the circuit breaker mounting screws (4 pcs.).</p> <p>③ Fit the supplied operating section mounting spacers (4 pcs.) between the circuit breaker and operating handle.</p> <p>④ Set the rotary plate to the OFF (symbol O) position, and install the operating section to the circuit breaker with the supplied operating section mounting screws.</p> 

### ② Installation of operating handle section

Drill a hole in the door according to the dimensional drawing for front plate drilling given on the previous page, and install the operating handle section in accordance with the following procedure.

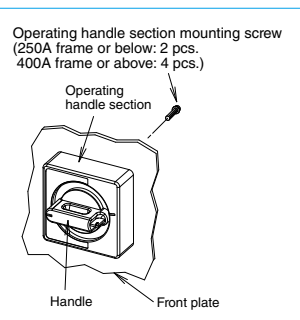

#### [Confirmation items]

- The handle should turn smoothly to the ON and OFF positions.
- When the handle is turned slightly in the ON direction (approx. 5 degrees) when in an OFF state, it should slowly return to the OFF position on its own. Furthermore, when in this state, the OFF position should not change when the handle is lightly forced in the reset direction.
- When released, the front plate should open and then immediately close.
- The operating handle section should be parallel with the breaker.

### ● Door locking mechanism

The operating handle is provided with an interlock mechanism to prevent the door opening in the ON and TRIP positions. In the OFF position, the door can be opened. However, the door can be opened in the ON or TRIP position by pressing the release knob in the arrow direction with a tool (3mm wide and 1.8mm thick).

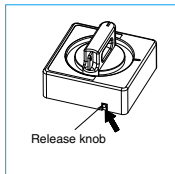

### ● Operation locking mechanism

#### ① Operating handle section

Operation lock can be set only in the OFF Position. Up to three commercially available padlocks (A = 35 or 40mm) can be fitted. Lockout hasps (scissors locks) can be used. When the operating handle section is locked with padlocks, also the door is locked.

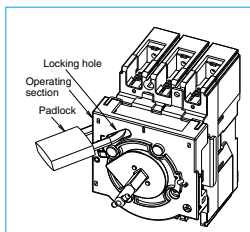

#### ② Operating section

The operating section can be locked so that the circuit breaker will not be turned on carelessly when the inside of the panel is inspected with the panel door open. Fit a padlock through the hole in the operating section of the operating handle.

### ● Adjusting unit

The height from the circuit breaker mounting surface to the panel door can be adjusted by fitting the optional adjusting unit V-AD3S or V-AD3L. Cut the shaft of the adjusting unit according to the height.

**Note** The adjusting unit is not applicable to 2-pole external type circuit breakers. If it is used on a 2-pole external type circuit breaker, the positions may not be correctly displayed.

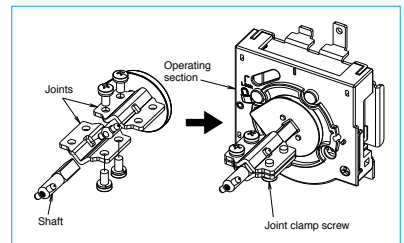

Make adjustments with the adjusting unit as stated below.

#### ① External dimension drawing

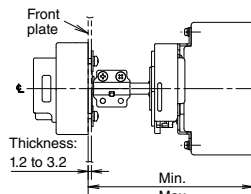

#### ② Calculation of shaft cutting allowance

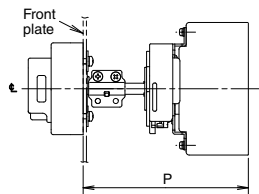

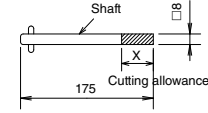
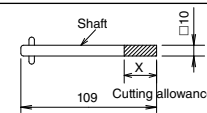
Type name	Dimensions (mm)		Cutting allowance	Calculation
	Min.	Max.		
V-05SV V-05SVUL V-1SV V-1SVUL V-1SUL	162	300		(Cutting allowance)(P max)(panel size) X = 300 mm - P
V-2SV V-2SVUL V-2SUL	180	318		
V-4S	233	300		
V-8S				
V-4SUL V-6SUL				

Note The unit is applicable to operating handles for emergency stop (E).

### ● Padlocks

The user must prepare padlocks.

The dimensions of the padlocks are the same as those shown on page 134.

### ● How to order

Specify the model name of the operating handle.

For adjustable type, place an order for the adjustment unit. (One lot includes 1 pc.)

250A frame or below: V-AD3S

400 to 800A frames: V-AD3L

### ● Interpretation of model name

(1) For 800A frame or below

$$\frac{V}{1) - \frac{1}{2) - \frac{S}{3) - \frac{UL}{4) - \frac{E}{5) - \frac{2}{6)}}$$

- V: Operating handle type name
- 1: Circuit breaker group (0.5, 1, 2, 4, 6 or 8)
- S: Classification of circuit breaker (S, SV, H, U, UV)
- UL: Blank...General product UL...UL 489 listed product
- E: Blank...Standard E...For emergency stop
- 2: Blank...3P or 4P 2...2P

### 3. C-type (cable-type) Operating Handle

- The panel door can only be opened in the OFF position.
- It has a safety device which prevents the circuit breaker turning on while the door is open.
- The handle can be locked only in the OFF position with up to three commercially available padlocks.
- The panel door can be opened in the ON position by turning the release knob.
- Protection class (IEC 60529) IP23 as standard.
- The handle does not provide an isolation function.

#### ● Outline drawings

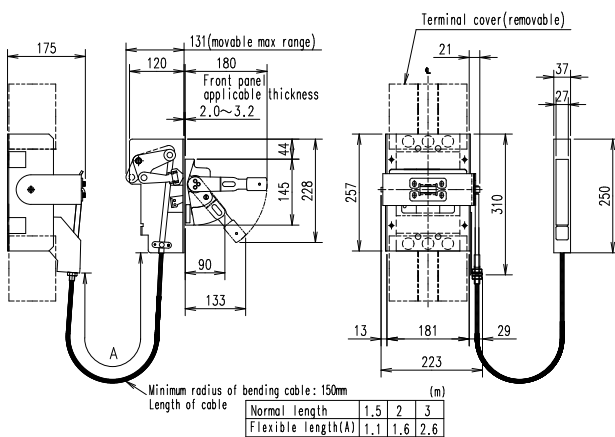
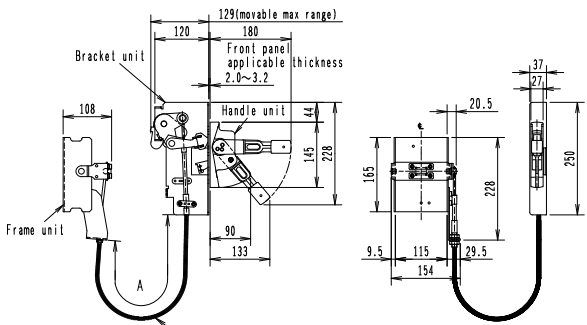
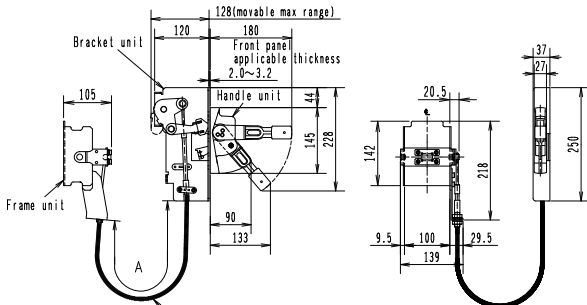

#### ● Dimensional drawings of circuit breaker mounting holes

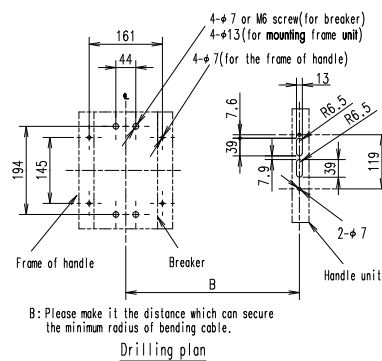
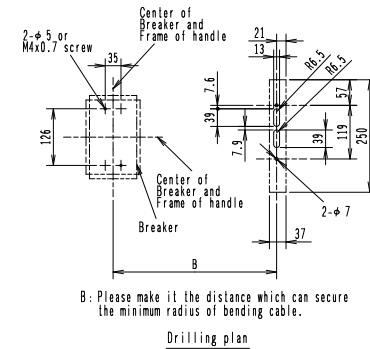
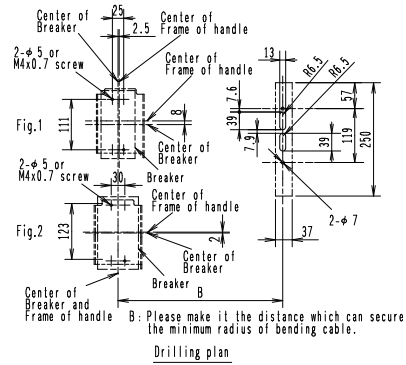

#### ● Door interlock drawing

Table 6-23

Type name	Applicable model		Number of poles	Reference drawing	
	MCCB	ELCB		Dimensional drawing	Drilling plan
C1SVU	NF100-CVFU	NV100-CVFU	3P	Fig.1	a
	NF125-SVU/HVU	NV125-SVU/HVU			
C2SVU	NF250-CVU/SVU/HVU	NV250-CVU/SVU/HVU		Fig.2	b
C4SWU	NF400-SWU/HWU	NV400-SWU/HWU		Fig.3	c

Notes \*1 Only 3-pole models are available.  
\*2 For internal accessories, only models with lead wires drawn out can be used.

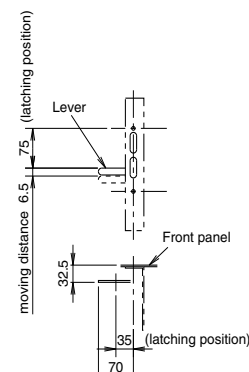

## 4. Terminal Covers

The terminal covers are used to avoid exposure of live parts. Many kinds of terminal covers, including large terminal covers (TC-L), small terminal covers (TC-S), transparent terminal covers (TTC), rear terminal covers (BTC) and plug-in terminal covers (PTC), for various models and applications are available, and they are helpful. (The terminal covers cannot be fitted to electrically operated circuit breakers of spring charged type (2) and motor-drive type (2). The standard terminal covers can be used for the spring charged type (1). For the motor-drive type, special terminal covers can be manufactured. Consult us for details.)

### ● Quick terminal covers

These covers are very convenient because they can be fitted only by inserting them into the mounting holes in the circuit breaker body. To remove the terminal cover, shift the projections of the terminal cover with the tip of a slotted screwdriver or finger, and draw it out.

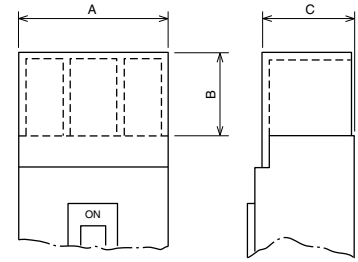

(TC-L-TC-S-TTC)

### ● Table of variable dimensions

Table 6-24 Large terminal covers (TC-L)

Type name	Color	Number of poles of circuit breaker	Applicable model		Dimensions (mm)			Contents			Appearance	Remarks
			MCCB	ELCB	A	B	C	Number of covers	Cover mounting screw	Sealing plate		
TCL-CP1	White	1	CP30-BA/HU	-	12.5	8.5	37/33.5	2	-	-	<p>Quick type The cover can be sealed with the sealing plate.</p>	
TCL-CP2	White	2	CP30-BA/HU	-	30	8.5	37/33.5	2	-	-		
TCL-CP3	White	3	CP30-BA/HU	-	47.5	8.5	37/33.5	2	-	-		
TCL-05FH2	White	2	NF50-FHU	NV50-FHU	50	27	55.5	2	-	-		
TCL-05FH3	White	3	NF50-FHU	NV50-FHU	75	27	55.5	2	-	-		
TCL-05SV2 (*1)(*7)	White	2	NF32-SV NF63-CV/SV/HV	-	50	25	65.5	2	-	2		
TCL-05SV2L (*1)(*8)	White	2	NF32-SV NF63-CV/SV/HV	-	50	40	65.5	2	-	2		
TCL-05SV3 (*2)(*7)	White	3	NF32-SV NF63-CV/SV/HV	NV32-SV, NV63-HV	75	25	65.5	2	-	2		
TCL-05SV3L (*2)(*8)	White	3	NF32-SV, NF63-CV/SV/HV	NV32-SV, NV63-HV	75	40	65.5	2	-	2		
TCL-05SV4 (*2)	White	4	NF63-SV/HV	-	100	25	65.5	2	-	2		
TCL-1SV2 (*1)	White	2	NF125-CV/SV	-	60	40	65.5	2	-	2		
TCL-1SV3 (*2)	White	3	NF125-CV/SV	NV125-CV/SV/HV	90	40	65.5	2	-	2		
TCL-1SV4 (*2)	White	4	NF125-SV/HV/UV	NV125-SV/HV	120	40	65.5	2	-	2		
TCL-1FH3	White	3	NF100-FHU	NV100-FHU	75	42	55.5	2	-	2		
TCL-2SV3 (*2)(*9)(*11)	White	2, 3	NF125-SGV/LGV/HGV/RGV NF160-SGV/LGV/HGV NF250-SGV/LGV/HGV/RGV NF250-CV/SV/HV/UV, NF250-SEV/HEV NF125-SEV/HEV	NV250-CV/SV/HV NV250-SEV/HEV NV125-SEV/HEV	105	40	65.5	2	-	2	<p>Screw type</p>	Use in combination with insulating barrier.
TCL-2SV3L (*2)(*10)(*11)	White	2, 3	NF125-SGV/LGV/HGV/RGV NF160-SGV/LGV/HGV NF250-SGV/LGV/HGV/RGV NF250-CV/SV/HV/UV, NF250-SEV/HEV NF125-SEV/HEV	NV250-CV/SV/HV NV250-SEV/HEV NV125-SEV/HEV	105	50	65.5	2	-	2		
TCL-2SV4 (*2)(*4)(*11)	White	4	NF250-SV/HV/UV NF250-SEV/HEV NF125-SEV/HEV (*5)	NV250-SV/HV NV250-SEV/HEV NV125-SEV/HEV	140	40	65.5	2	-	2		
TCL-4SW3 (*2)	White	2, 3	NF400-CW/SW/SEW NF630-CW/SW/SEW	NV400-CW/SW/SEW NV630-CW/SW/SEW	171	110	99.5	2	-	2		
	White	3	NF400-SEW with MDU (*6) NF400-UEW (*3)	-	171	110	132.5/196.5	2	-	-		
TCL-4SW4 (*2)	White	4	NF400-SW/SEW/HEW NF630-SW/SEW NF400-SEW with MDU (*6)	NV400-SEW/HEW NV630-SEW	240	110	105	2	6	-		
TCL-8SW3 (*2)	White	2, 3	NF800-CEW/SDW/SEW/HEW/REW NF800-SEW with MDU/HEW with MDU (*6)	NV800-SEW/HEW	224	155	103.5	2	4	-		
TCL-8UW3	Transparent	3	NF800-UEW (*3)	-	220	155	146/194.5	2	4	-		
TCL-8SW4 (*2)	White	4	NF800-SEW/HEW NF800-SEW with MDU/HEW with MDU (*6)	-	294	155	103.5	2	6	-		
TCL-8UW4	Transparent	4	NF400-UEW, NF800-UEW (*3)	-	290	155	146/194.5	2	6	-		
TCL-10SW3	Transparent	3	NF1000-SEW NF1250-SEW/SDW	-	220	150	139	2	4	-		
TCL-10SW4	Transparent	4	NF1000-SEW NF1250-SEW/SDW	-	290	150	139	2	4	-		
TCL-05SRU2 (*2)	White	2	NF100-SRU NF100-HRU	NF100-SRU	50	40	66 72	2	4	-		
TCL-05SRU3 (*2)	White	3	NF100-SRU NF100-HRU	NF100-SRU	75	40	66 72	-	-	-		
TCL-03SVU2 (*2)	White	2	NF50-SVFU	NV50-SVFU	36	30	65.5	2	-	-		
TCL-03SVU3 (*2)	White	3	NF50-SVFU	NV50-SVFU	54	30	65.5	2	-	-		
TCL-05SVU2 (*1)(*7)	White	2	NF100-CVFU	-	50	25	65.5	2	2	-		
TCL-05SVU2L (*1)(*8)	White	2	NF100-CVFU	-	50	40	65.5	2	2	-		
TCL-05SVU3 (*2)(*7)	White	3	NF100-CVFU	NV100-CVFU	75	25	65.5	2	2	-		
TCL-05SVU3L (*2)(*8)	White	3	NF100-CVFU	NV100-CVFU	75	40	65.5	2	2	-		
TCL-1SVU3 (*2)	White	2, 3	NF125-SVU NF125-HVU	-	90	40	65.5	2	2	-		
TCL-2SVU3 (*2)(*9)	White	3	NF250-CVU/SVU/HVU	NV250-CVU/SVU/HVU	105	40	65.5	2	2	-		
TCL-2SVU3L (*2)(*10)	White	3	NF250-CVU/SVU/HVU	NV250-CVU/SVU/HVU	105	50	65.5	2	2	-		
TCL-4SWU	White	3	NF400-SWU/HWU	-	171	110	99.5	2	-	2		
TCL-6SWU	Transparent	3	NF630-SWU/HWU	-	224	155	103.5	2	4	-		

Notes \*1 For a circuit breaker with F or V type operating handle, specify the model name with F at the end.  
(F or V type operating handle dedicated models, screws are used for fixing.)  
\*2 The standard models can be used in combination with F and V Type Operating Handles.  
\*3 The dimension C is the size on the power supply side and load side.  
\*4 When a crimp terminal applicable to wires with a size of 117.2 to 152.05mm<sup>2</sup> (Model 2CR-150 or CB150-S8) is used, TC-L cannot be fitted. Insulate the terminal from TC-S with insulating tube or taping.  
\*5 In the case of installation on the body, specify the model name with-MDU at the end.  
\*6 It cannot be installed in the case of installation on the body.  
\*7 Applicable to circuit breakers with rating of 75A or less (max. wire size 25mm<sup>2</sup>)

\*8 Applicable to circuit breakers with rating of 125A or less (max. wire size 60mm<sup>2</sup>)  
\*9 Applicable to circuit breakers with rating of 200A or less (max. wire size 100mm<sup>2</sup>)  
\*10 Applicable to circuit breakers with rating of 250A or less (max. wire size 150mm<sup>2</sup>) (Applicable to UL wire 300kcmil)  
\*11 For NF125-HEV, NF250-HEV, NV125-HEV and NV250-HEV with PAL, specify the model name with MP at the end.  
Remarks 1. The wire sizes shown in the above notes \*8 to \*11 are those of the 600V vinyl insulated wires.  
2. Insulate the exposed live parts of crimp terminals with insulating tape or the like.  
3. When protection from the power supply and load sides is necessary, separately consult us.

**Table 6-25 Small terminal covers (TC-S)**

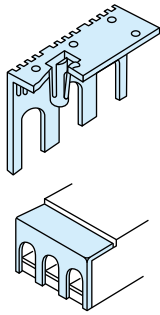
Type name	Color	Number of poles of circuit breaker	Applicable model		Dimensions (mm)			Contents			Appearance	Remarks
			MCCB	ELCB	A	B	C	Number of covers	Cover mounting screw	Sealing plate		
TCS-05FA2 (*6)	White	2	NF30-FAU, NF50-FAU	NV30-FAU, NV50-FAU	40	7	55	2	-	-	 <p>Quick type The cover can be sealed with the sealing plate.</p>	
TCS-05FA3 (*6)	White	3			60	7	55	2	-	-		
TCS-05FH2 (*7)	White	2	NF50-FHU	NV50-FHU	50	5	55.5	2	-	-		
TCS-05FH3 (*7)	White	3			75	5	55.5	2	-	-		
TCS-05SV2 (*1)	White	2	NF32-SV, NF63-CV/SV/HV	-	50	5	65.5	2	-	2		
TCS-05SV3	White	3	NF32-SV, NF63-CV/SV/HV	NV32-SV, NV63-HV	75	5	65.5	2	-	2		
	(*2)	White	2, 3	-								
TCS-05SV4	White	4	NF63-SV/HV	-	100	5	65.5	4	-	4		
TCS-1SV2 (*2)	White	2	NF125-CV/SV	-	60	6.5	65.5	2	-	2		
TCS-1SV3	White	3	NF125-CV/SV	NV125-CV/SV/HV	90	6.5	65.5	2	-	2		
	White	2, 3	NF125-HV/UV	-								
TCS-1SV4	White	4	NF125-SV/HV/UV	NV125-SV/HV	120	6.5	65.5	4	-	4		
TCS-1FH3	White	3	NF100-FHU	NV100-FHU	75	5	55.5	2	-	2		
TCS-2SV3	White	2, 3	NF125-SGV/LGV/HGV/RGV	NV250-CV/SV/HV	105	6.5	65.5	2	-	2		
			NF160-SGV/LGV/HGV	NV250-SEV/HEV								
TCS-2SV4 (*3)	White	4	NF250-SGV/LGV/HGV/RGV	NV125-SEV/HEV	140	6.5	65.5	2	-	2		
			NF250-CV/SV/HV/UV, NF250-SEV/HEV	-								
			NF125-SEV/HEV	NV125-SEV/HEV								
			NF125-SGV/LGV/HGV	-								
TCS-05SRU2	White	2	NF100-SRU	NV100-SRU	50	5	66	2	-	2		
	(*2)		White	NF100-HRU			-				72	
	White		3	NF100-SRU			NV100-SRU				66	
TCS-05SRU3	White	3	NF100-SRU	NV100-SRU	75	5	66	2	-	2		
	(*2)		White	NF100-HRU			NV100-HRU				72	

Notes \*1 For a circuit breaker with F type operating handle, specify the model name with F at the end.  
(F type operating handle dedicated models, screws are used for fixing.)  
\*2 The standard models can be used in combination with F and V Type Operating Handles.  
\*3 For NF125-HEV, NF250-HEV, NV125-HEV and NV250-HEV with PAL, specify the model name with MP at the end.

\*6 When a crimp terminal applicable to wires with a size of 16.78 to 22.66mm<sup>2</sup> (Model JST-22-5NS) used, TC-S cannot be fitted. Insulate with insulating tape or the like.  
\*7 When a crimp terminal applicable to wires with a size of 16.78 to 22.66mm<sup>2</sup> (Model JST-22-5S and BH-22) used, TC-S cannot be fitted. Insulate with insulating tape or the like.  
Remark: 1. Insulate the exposed live parts of crimp terminals with insulating tape or the like.

**Table 6-26 Transparent terminal covers (TTC)**

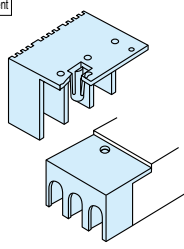
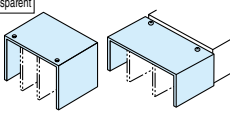
Type name	Number of poles of circuit breaker	Applicable model		Dimensions (mm)			Contents			Appearance	Remarks
		MCCB	ELCB	A	B	C	Number of covers	Cover mounting screw	Sealing plate		
TTC-05SV2 (*1)	2	NF32-SV	-	50	25	65.5	2	-	2	 <p>Transparent</p> <p>Quick type The cover can be sealed with the sealing plate.</p>	
TTC-05SV3	3	NF32-SV	NV32-SV, NV63-HV	75	25	65.5	2	-	2		
	(*2)	2, 3	-								
TTC-05SV4	4	NF63-SV/HV	-	100	25	65.5	2	-	2		
TTC-1SV2 (*1)	2	NF125-CV/SV	-	60	40	65.5	2	-	2		
TTC-1SV3	3	NF125-CV/SV	NV125-CV/SV/HV	90	40	65.5	2	-	2		
	(*2)	2, 3	NF125-HV/UV								
TTC-1SV4	4	NF125-SV/HV/UV	NV125-SV/HV	120	40	65.5	2	-	2		
TTC-2SV3	2, 3	NF125-SGV/LGV/HGV/RGV	NV250-CV/SV/HV	105	40	65.5	2	-	2		
		NF160-SGV/LGV/HGV	NV250-SEV/HEV								
TTC-2SV4 (*6)	4	NF250-SGV/LGV/HGV/RGV	NV125-SEV/HEV	140	40	65.5	2	-	2		
		NF250-CV/SV/HV/UV, NF250-SEV/HEV	-								
		NF125-SEV/HEV	NV125-SEV/HEV								
		NF125-SGV/LGV/HGV	-								
TTC-4SW3	2, 3	NF400-CW/SW/SEW	NV400-CW/SW/SEW	171	110	104.5	2	4	-		
	3	NF400-HEW/REW	NV400-HEW								
TTC-4SW4	4	NF630-CW/SW/SEW	NV630-CW/SW/SEW	240	110	104.5	2	6	-		
		NF630-HEW/REW	NV630-HEW								
TTC-8SW3	2, 3	NF400-SW/SEW/HEW	NV400-SEW/HEW	224	155	103.5	2	4	-		
	3	NF800-SEW with MDU/HEW with MDU (*4)	-								
TTC-8SW4	4	NF800-SEW/HEW	-	294	155	103.5	2	6	-	 <p>Transparent</p> <p>Screw type</p>	Use in combination with insulating barrier.

Notes \*1 For a circuit breaker with F type operating handle, specify the model name with F at the end.  
(F type operating handle dedicated models, screws are used for fixing.)  
\*2 The standard models can be used in combination with F and V Type Operating Handles.  
\*3 When a crimp terminal applicable to wires with a size of 117.2 to 152.05mm<sup>2</sup> (Model 2CR-150 or CB150-S8) is used, TTC cannot be fitted.  
Use TCL-2SV3L. Or insulate the terminal from TC-S with insulating tube or taping.

\*4 In the case of installation on the body, specify the model name with • MDU at the end.  
\*5 Applicable to circuit breakers with rating of 200A or less (max. wire size 100mm<sup>2</sup>)  
\*6 For NF125-HEV, NF250-HEV, NV125-HEV and NV250-HEV with PAL, specify the model name with MP at the end.  
Remark: 1. There is also a 4-poles product.

# 6 Accessories 2 External Accessories

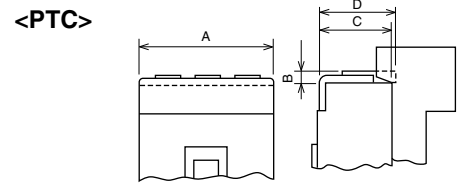
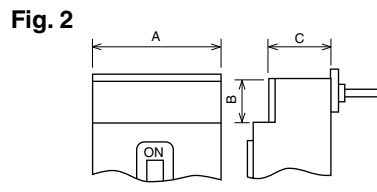
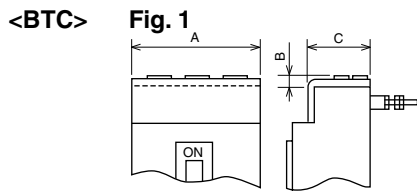

**Table 6-27 Rear terminal cover (BTC)**

Type name	Color	Number of poles of circuit breaker	Applicable model		Dimensions (mm)			Contents			Appearance	Remarks		
			MCCB	ELCB	A	B	C	Number of covers	Cover mounting screw	Sealing plate				
BTC-05SV2	White	2	NF32-SV NF63-CV/SV/HV	- (*1)	50	5	65.5	2	-	2		Cover for stud connection block on back in the case of rear connection type		
BTC-05SV3	White	3	NF32-SV NF63-CV/SV/HV	NV32-SV, NV63-HV	75	5	65.5	2	-	2				
BTC-05SV4	White	4	NF63-SV/HV	-	100	5	65.5	4	-	4				
BTC-1SV2	White	2	NF125-CV/SV	-	60	6.5	65.5	2	-	2				
BTC-1SV3	White	3	NF125-CV/SV	NV125-CV/SV/HV	90	6.5	65.5	2	-	2				
BTC-1SV4	White	4	NF125-SV/HV	-	120	6.5	65.5	4	-	4				
BTC-2SV3	(*6) White	2, 3	NF125-SGV/LGV/HGV/RGV NF160-SGV/LGV/HGV NF250-SGV/LGV/HGV/RGV NF250-CV/SV/HV/UV, NF250-SEV/HEV NF125-SEV/HEV	NV250-CV/SV/HV NV250-SEV/HEV NV125-SEV/HEV	105	6.5	65.5	2	-	2				
BTC-2SV4	(*6) White	4	NF125-SEV/HEV NF125-SGV/LGV/HGV NF160-SGV/LGV/HGV NF250-SV/HV/UV NF250-SEV/HEV NF250-SGV/LGV/HGV	NV125-SEV/HEV -	140	6.5	65.5	2	-	2				
BTC-4SW3	White	2, 3	NF400-CW/SW/SEW NF630-CW/SW/SEW	NV400-CW/SW/SEW NV630-CW/SW/SEW	140	42 (*2)	99.5	2	-	2			Quick type The cover can be sealed with the sealing plate.	
	White	3	NF400-SEW with MDU (*5) NF400-UEW (*4)	- (*5)	140	42 (*2)	132.5/ 196.5	2	-	-				
BTC-4SW4	(*3) Transparent	4	NF400-SW/SEW/HEW NF630-SW/SEW/HEW NF400-SEW with MDU/HEW with MDU (*5)	NV400-SEW/HEW NV630-SEW	185	42 (*2)	97.5	2	6	-		Screw type		
BTC-8SW3	(*3) Transparent	2, 3	NF800-CEW/SDW/SEW/HEW/REW NF800-SEW with MDU/HEW with MDU (*5)	NV800-SEW/HEW	210	32 (*2)	97.5	2	8	-				
	Transparent	3	NF800-UEW (*4)	-	210	32 (*2)	146/ 194.5	2	4	-				
BTC-8SW4	(*3) Transparent	4	NF800-SEW/HEW NF800-SEW with MDU/HEW with MDU (*5) NF400-UEW, NF800-UEW (*4)	- (*5)	280	32 (*2)	97.5	2	10	-				
	Transparent	4	NF400-UEW, NF800-UEW (*4)	-	280	32 (*2)	146/ 194.5	2	6	-				

- Notes
- \*1 For 2-pole ELCB, use BTC for 3-pole circuit breaker.
  - \*2 Dimension B in Fig. 2
  - \*3 The covers can be used for plug-in type circuit breakers. Other models are designed only for rear connection type.
  - \*4 The dimension C is the size on the power supply side and load side.
  - \*5 In the case of installation on the body, it can be fitted only on the power supply side.
  - \*6 For NF125-HEV, NF250-HEV, NV125-HEV and NV250-HEV with PAL, specify the model name with MP at the end.

- Remarks
1. PTC-4SW3 can be used as the back terminal covers for NF400-HEW/REW, NF630-HEW/REW, NV400-HEW and NV630-HEW.
  2. For terminal covers for 4-pole circuit breakers not listed above, consult us.

**Table 6-28 Plug-in terminal covers (PTC)**

Type name	Color	Number of poles of circuit breaker	Applicable model		Dimensions (mm)				Contents			Appearance	Remarks	
			MCCB	ELCB	A	B	C	D	Number of covers	Cover mounting screw	Sealing plate			
PTC-05SV2	White	2	NF32-SV NF63-CV/SV/HV	-	50	6.5	65.5	72	2	2	-		Cover for stud connection block in the case of plug-in type	
PTC-05SV3	White	3	NF32-SV NF63-CV/SV/HV	NV32-SV, NV63-HV	75	6.5	65.5	72	2	2	-			
PTC-05SV4	White	4	NF63-SV/HV	-	100	6.5	65.5	72	4	4	-			
PTC-1SV2	White	2	NF125-CV/SV	-	60	6.5	65.5	-	2	4	-			
PTC-1SV3	White	3	NF125-CV/SV	NV125-CV/SV/HV	90	6.5	65.5	-	2	4	-			
PTC-1SV4	White	4	NF125-SV/HV	-	120	6.5	65.5	-	4	4	-			
PTC-2SV3	White	2, 3	NF125-SGV/LGV/HGV/RGV NF160-SGV/LGV/HGV NF250-SGV/LGV/HGV/RGV NF250-CV/SV/HV/UV, NF250-SEV/HEV NF125-SEV/HEV	NV250-CV/SV/HV NV250-SEV/HEV NV125-SEV/HEV	105	6.5	65.5	78.5	2	4	-			
PTC-2SV4	White	4	NF125-SEV/HEV NF125-SGV/LGV/HGV NF160-SGV/LGV/HGV NF250-SV/HV/UV NF250-SEV/HEV NF250-SGV/LGV/HGV	NV125-SEV/HEV -	140	6.5	65.5	78.5	2	2	-			
PTC-4SW3	(*2) Transparent	2, 3	NF400-CW/SW/SEW NF630-CW/SW/SEW NF400-HEW/REW (*1) NF630-HEW/REW (*1)	NV400-CW/SW/SEW NV630-CW/SW/SEW NV400-HEW (*1) NV630-HEW (*1)	140	42	97.5	-	2	4	-			Same as screw type of BTC

- Notes
- \*1 The covers can be used as back terminal covers.
  - \*2 See Fig. 2 of BTC.

**Table 6-29 List of terminal covers applicable to F and V Type Operating Handles**

Type name			Applicable operating handles	Number of poles of circuit breaker	Applicable model	
Large terminal covers (TC-L)	Small terminal covers (TC-S)	Transparent terminal covers (TTC)			MCCB	ELCB
TCL-05SV2F (*2)(*3) TCL-05SV2LF (*2)(*4)	TCS-05SV2F (*2)	TTC-05SV2F (*2)	F-05SV2, V-05SV2	2	NF32-SV, NF63-CV/SV/HV	– (*1)
TCL-05SV3 (*3) TCL-05SV3L (*4)	TCS-05SV3	TTC-05SV3	F-05SV, V-05SV	3	NF32-SV, NF63-CV/SV/HV	NV32-SV, NV63-HV
TCL-05SV4	–	–		2, 3	–	NV63-CV/SV
TCL-1SV2F (*2)	TCS-1SV2F (*2)	TTC-1SV2F (*2)	F-1SV2, V-1SV2	4	NF32-SV, NF63-CV/SV/HV	–
TCL-1SV3	TCS-1SV3	TTC-1SV3	F-1SV, V-1SV	2	NF125-CV/SV	–
TCL-1SV4	–	–		3	NF125-CV/SV	NV125-CV/SV/HV
TCL-2SV3 (*5) TCL-2SV3L (*6)(*7)	TCS-2SV3	TTC-2SV3	F-2SV, V-2SV	2, 3	NF125-HV/UV	–
TCL-2SV4 (*7)	–	–		4	NF125-CV/SV/HV/UV	NV125-CV/SV/HV
TCL-4SW3 TCL-4SP3W	–	TTC-4SW3	F-4S V-4S	2, 3	NF125-CV/SV/HV/UV, NF250-SEV/HEV NF125-SEV/HEV	NV250-CV/SV/HV, NV250-SEV/HEV NV125-SEV/HEV
TCL-4SW4	–	TTC-4SW4		4	NF250-CV/SV/HV/UV, NF250-SEV/HEV NF125-SEV/HEV	NV250-CV/SV/HV, NV250-SEV/HEV NV125-SEV/HEV
TCL-8SW3 TCL-8SW4	–	TTC-8SW3 TTC-8SW4	F-8S V-8S	2, 3	NF400-CW/SW/SEW/HEW/REW NF630-CW/SW/SEW/HEW/REW	NV400-CW/SW/SEW/HEW NV630-CW/SW/SEW/HEW
	–	–		4	NF400-SW/SEW/HEW NF630-SW/SEW/HEW	NV400-SEW/HEW NV630-SEW
	–	–		2, 3	NF800-CEW/SDW/SEW/HEW/REW	NV800-SEW/HEW
	–	–		4	NF800-SEW/HEW	–

- Notes
- \*1 For 2-pole NV, use a terminal cover for 3-pole circuit breaker.
  - \*2 Only for F and V Type Operating Handles (screw type)
  - \*3 Applicable to circuit breakers with rating of 75A or less (max. wire size 25mm<sup>2</sup>)
  - \*4 Applicable to circuit breakers with rating of 125A or less (max. wire size 60mm<sup>2</sup>)
  - \*5 Applicable to circuit breakers with rating of 200A or less (max. wire size 100mm<sup>2</sup>)
  - \*6 Applicable to circuit breakers with rating of 250A or less (max. wire size 150mm<sup>2</sup>)
  - \*7 For NF125-HEV, NF250-HEV, NV125-HEV and NV250-HEV with PAL, specify the model name with MP at the end.

Remark: 1. The terminal covers for UL 489 Listed Circuit Breakers can be normally combined with F Type Operating Handles.

## 5. Insulating Barriers

The insulating barrier enhances the insulation between the phases of circuit breaker terminals. It also prevents accidents due to conductive foreign matter and dust, and secondary accidents when isolating a fault current.

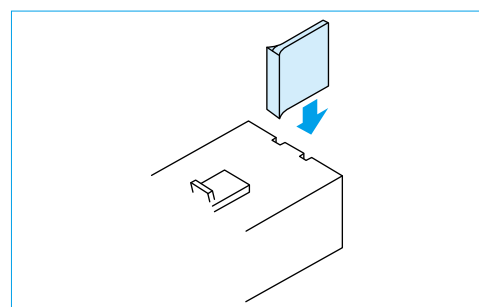

● The insulating barrier is available for the models listed in the table below.

**Table 6-30**

(“●” denotes optional)

Applicable model		Connecting method			
MCCB	ELCB	Front	Rear	Flush plate	Plug-in
NF32-SV, NF63-CV NF125-CV, NF100-CV-FU NF100-SRU	NV32-SV, NV63-CV NV125-CV, NV100-CV-FU NV100-SRU	●	–	–	–
NF63-SV/HV NF125-SV/HV NF100-HRU	NV63-SV/HV NV125-SV/HV NV100-HRU	Standard attachment	–	–	–
NF125-SEV/HEV NF250-CV/SV/HV/SEV/HEV NF125-SGV/LGV/HGV/RGV NF160-SGV/LGV/HGV NF250-SGV/LGV/HGV/RGV NF250-SEV/HEV with MDU	NV125-SEV/HEV NV250-CV/SV/HV/SEV/HEV NV250-SEV/HEV with MDU	Standard attachment	–	–	Standard attachment
NF125-SVU NF125-HVU NF250-SVU NF250-HVU NF250-CVU	NV125-SVU NV125-HVU NV250-SVU NV250-HVU NV250-CVU	Standard attachment	–	–	–
NF400-CW/SW/SEW/HEW/REW/UEW NF630-CW/SW/SEW/HEW/REW	NV400-CW/SW/SEW/HEW NV630-CW/SW/SEW/HEW	Standard attachment	●	●	Standard attachment
NF400-UEW(4P) NF800-CEW/SEW/HEW/REW/SDW	NV800-SEW/HEW	Standard attachment	●	●	●
NF800-UEW	–	Standard attachment	●	●	–
NF400-SWU/HWU NF630-SWU/HWU	–	Standard attachment	–	–	–
NF1000-SEW, NF1250-SEW/SDW	–	Standard attachment	–	–	Standard attachment
NF1600-SEW/SDW	–	Standard attachment	–	–	–

Always mount the insulating barrier when it comes with the circuit breaker.

## ● Insulating Barrier-Front (BA-F)

**Table 6-31 Summary of dimensions**

Type name	Applicable model		Dimensions (mm)		Quantity per breaker			Reference diagram
	MCCB	ELCB	A	B	2P	3P	4P	
BAF-05SRU	NF100-SRU/HRU	NV100-SRU/HRU	50	59.5	1	2	-	
BAF-05SV	NF32-SV NF63-CV NF125-CV	NV32-SV NV63-CV NV125-CV	50	59.5	1 (*2)	2	3	
	NF63-SV/HV NF125-SV/HV/UV	NV63-SV/HV NV125-SV/HV						
BAF-2SV	NF125-SEV/HEV NF125-SGV/LGV/HGV/RGV NF160-SGV/LGV/HGV NF250-CV/SV/HV/UV/SEV/HEV NF250-SGV/LGV/HGV/RGV NF250-SEV/HEV with MDU	NV125-SEV/HEV NV250-CV/SV/HV/SEV/HEV NV250-SEV/HEV with MDU	100	59.5	2	4	6	
	BAF-05SVU	NF100-CVUFU NF125-SVU NF125-HVU						
BAF-2SVU	NF250-SVU NF250-HVU NF250-CVU	NV250-SVU NV250-HVU NV250-CVU	100	59.5	-	4	-	
BAF-4SW	NF400-CW/SW/SEW/HEW/REW NF630-CW/SW/SEW/HEW/REW	NV400-CW/SW/SEW/HEW NV630-CW/SW/SEW/HEW						
BAF-4UW (*1)	NF400-UEW(3P)	-	110	132/ 98.5	-	4	-	
BAF-8SW	NF800-CEW/SEW/SDW/HEW/REW	NV800-SEW/HEW						
BAF-10SW	NF400-UEW(4P) NF800-UEW, NF1000-SEW NF1250-SEW/SDW	-	110	132	1	2	3	
	BAF-4SWU	NF400-SWU/HWU						
		NF630-SWU/HWU(less than 600A)	-	110	98.5	-	2	
BAF-6SWU	NF630-SWU/HWU(630A)	-	150					
BAF-16SW	NF1600-SEW/SDW	-		185	132	1	2	3

Notes \*1 The barriers BAF-4UW for the power supply and load sides vary in the dimension B.  
\*2 Not supplied with ELCB.

## ● Insulating Barrier-Rear (BA-B)

**Table 6-32 Summary of dimensions**

Type name	Applicable model		Dimensions (mm)		Quantity per breaker			Reference diagram
	MCCB	ELCB	A	B	2P	3P	4P	
BAB-4SW	NF400-CW/SW/SEW/HEW/REW NF400-UEW(3P) NF630-CW/SW/SEW/HEW/REW	NV400-CW/SW/SEW/HEW NV630-CW/SW/SEW/HEW	140	74.5	-	4	6	
BAB-8SW	NF800-CEW/SEW/SDW/HEW/REW NF400-UEW(4P) NF800-UEW	NV800-SEW/HEW	140	74.5	-	4	6	

Drilling size for use of BA-B (in the case of 3-pole circuit breaker)

NF400-CW, NF400-SW, NF400-SEW, NF400-HEW, NF400-REW, NF400-UEW NV400-CW, NV400-SW, NV400-SEW, NV400-HEW NF630-CW, NF630-SW, NF630-SEW, NF630-HEW, NF630-REW NV630-CW, NV630-SW, NV630-SEW, NV630-HEW		NF800-CEW, NF800-SEW, NF800-HEW, NF800-REW, NF800-UEW NV800-SEW, NV800-HEW	
Power supply side	Note The dimensions in brackets are those for NF400-UEW.	Load side	Note The dimensions in brackets are those for NF800-UEW.

The drilling size drawings show the dimensions viewed from the rear side.

## ● Insulating Barrier-Plug-in (BA-P)

**Table 6-33 Summary of dimensions**

Type name	Applicable model		Dimensions (mm)		Quantity per breaker			Reference diagram
	MCCB	ELCB	A	B	2P	3P	4P	
BAP-2SV	NF125-SEV/HEV NF125-SGV/LGV/HGV/RGV NF160-SGV/LGV/HGV NF250-CV/SV/HV NF250-SGV/LGV/HGV/RGV NF250-SEV/HEV	NV125-SEV/HEV NV250-CV/SV/HV/SEV/HEV	172	74.5	4			
BAP-4SW	NF400-CW/SW NF400-SEW/HEW/REW/UEW NF630-CW/SW NF630-SEW/HEW/REW	NV400-CW/SW NV400-SEW/HEW NV630-CW/SW NV630-SEW/HEW	178	74.5		4	6	
BAP-8SW	NF800-CEW/SEW NF800-HEW/REW	NV800-SEW/HEW	172	74.5	-			
	NF1000-SEW NF1250-SEW	-	215	74.5				

## ● Earth fault preventing barriers (BA-G)

**Table 6-34 Summary of dimensions**

Type name	Applicable model		Dimensions (mm)		Quantity per breaker	Reference diagram
	MCCB	ELCB	A	B		
BAG-05SV3	NF32-SV NF63-CV/SV/HV	NV32-SV NV63-CV/SV/HV	30	75	1	<p>Earth fault preventing barrier (3 poles)</p>
BAG-1SV3	NF125-CV/SV/HV	NV125-CV/SV/HV	40	90		
BAG-2SV3	NF125-SEV/HEV NF250-CV/SV/HV/SEV/HEV NF250-SEV/HEV with MDU	NV125-SEV/HEV NV250-CV/SV/HV/SEV/HEV NV250-SEV/HEV with MDU	63	105		
BAG-4SW3	NF400-CW/SW/SEW/HEW/REW NF630-CW/SW/SEW/HEW/REW	NV400-CW/SW/SEW/HEW NV630-CW/SW/SEW/HEW	63	164		
BAG-4UW3	NF400-UEW	-	63	164		
BAG-8SW3	NF800-CEW/SEW/SDW/HEW/REW	NV800-SEW/HEW	110	210		
BAG-8UW3	NF800-UEW	-	110	210		
BAG-10SW3	NF1000-SEW NF1250-SEW/SDW	-	98	210		
BAG-16SW3	NF1600-SEW/SDW	-	150	300		

Also the earth fault preventing barriers for 2- and 4-pole circuit breakers are available.

## 6. Handle Lock Devices, Lock Covers, Auxiliary Handles, Card Holders

### (1) Handle Lock Devices (HL and HL-S)

These devices are used to lock the circuit breakers in the ON or OFF position. If overcurrent flows while the circuit breaker is locked, it will trip. Model HL (red resin moldings) to be fitted to handles and Model HL-S to be secured on circuit breaker covers are available. (Use a commercially available padlock having the nominal size shown in the right table. If a padlock in another size is used, the device may not lock correctly.)

Padlock size (mm)

Application	A (Nominal size)	B
a	25	4 or less
b	35	5 or less
c	40	6 or less

Table 6-35 HL

Type name	Applicable model		Reference diagram	Padlock
	MCCB	ELCB		
HL-05FH	NF50-FHU, NF100-FHU	NV50-FHU, NV100-FHU	Fig. 4	
HL-05FA	NF30-FA/FAU, NF50-FA/FAU	NV30-FA/FAU, NV50-FA/FAU		
HLF-05BHD	BH-D6, BH-D10	-	Fig. 5	
HLF-05SMU (*1)	NF50-SMU	-		
HLF-05SRU	NF100-SRU/HRU	NV100-SRU/HRU	-	
HLN-05SV	NF32-SV, NF63-CV/SV/HV	NV32-SV, NV63-CV/SV/HV	Fig. 1	a
	NF125-CV/SV/HV/UV, NF125-SEV/HEV			
	NF125-SGV/LGV/HGV/RGV			
	NF160-SGV/LGV/HGV			
	NF250-CV/SV/HV/UV, NF250-SEV/HEV			
HLF-05SV	NF32-SV, NF63-CV/SV/HV	NV32-SV, NV63-CV/SV/HV	Fig. 1	
	NF125-CV/SV/HV/UV, NF125-SEV/HEV			
	NF125-SGV/LGV/HGV/RGV			
	NF160-SGV/LGV/HGV			
	NF250-CV/SV/HV/UV, NF250-SEV/HEV			
HLF-05SVU	NF125-SVU/HVU	NV125-SVU/HVU	-	
	NF250-SVU/HVU/CVU			
HL-4CW (*1)	NF400-CW	NV400-CW	Fig. 2	c
HL-4SW (*1)	NF400-SW/SEW/HEW/REW/UEW	NV400-SW/SEW/HEW		
	NF630-CW/SW/SEW/HEW/REW			
HL-4SWU	NF800-CW/SDW/SEW/HEW/REW/UEW	NV800-SW/SEW/HEW		
HL (*2)	NF400-SWU/HWU, NF630-SWU/HWU	-	Fig. 3	

Notes \*1 When a padlock is not used, the device can be used as a lock cover (LC).  
 \*2 Place an order for a circuit breaker body combined with the device.

Remarks 1. One lot of HL-4CW and HL-4SW contains one piece, and one lot of others contains 10 pieces.  
 2. HLF types are used for OFF lock, and HLN types for ON lock.

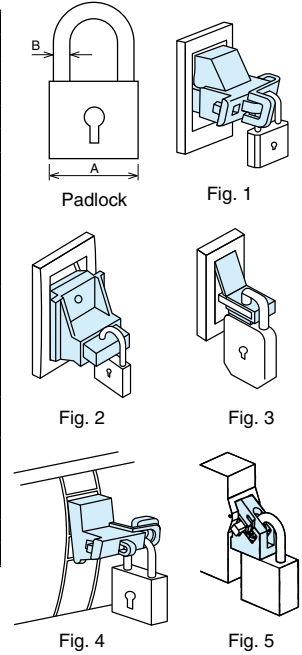

Table 6-36 HL-S

Type name	Applicable model				Dimensions (mm)						Reference diagram	Padlock
	MCCB	Number of poles	ELCB	Number of poles	A	B	C	D	E	F		
HLS-05SV2 (*1)	NF32-SV, NF63-CV, NF63-SV	2P	-	-	32	75	50	-	-	-	32	
	NF63-HV											
HLS-05SV (*1)	NF125-CV, NF125-SV	2P	-	-	32	75	75	23	-	-	32	Fig. 5
	NF32-SV, NF63-CV, NF63-SV	3P	NV32-SV, NV63-CV, NV63-SV, NV63-HV	3P								
	NF63-SV, NF63-HV	4P	-	-								
	NF125-CV, NF125-SV	3P	NV125-CV, NV125-SV, NV125-HV	3P								
	NF125-HV	2P, 3P	-	-								
	NF125-SV, NF125-HV	4P	NV125-SV, NV125-HV	4P								
	NF125-UV	2P, 3P	-	-								
HLS-2SV (*1)	NF125-SGV/LGV/HGV/RGV	2P	NV125-SEV, NV125-HEV	3P	32	84	100	-	63	-	32	b
	NF160-SGV/LGV/HGV											
	NF250-CV, NF250-SV, NF250-HV	3P	NV250-CV, NV250-SV, NV250-HV	3P								
	NF250-SGV/LGV/HGV/RGV											
	NF125-SEV, NF125-HEV	4P	NV125-SEV, NV125-HEV	4P								
	NF125-SGV/LGV/HGV/RGV											
	NF160-SGV/LGV/HGV	4P	NV250-SV, NF250-HEV	4P								
NF250-CV, NF250-SV, NF250-HV												
NF250-SGV/LGV/HGV/RGV	2P, 3P	-	-	69.5	-	-	-	-	-	-		
HLS-03SVU (*1)	NF50-SVFU	2P, 3P	NV50-SVFU	2P, 3P	-	-	-	-	-	-	-	Fig. 8
HLS-05SVU2 (*1)	NF100-CVFU	2P	-	-	32	75	50	-	-	-	32	Fig. 5
HLS-05SVU (*1)	NF100-CVFU	3P	NV100-CVFU	3P								
	NF125-SVU/HVU	2P, 3P	NV125-SVU/HVU	3P								
HLS-05SVU (*2)	NF125-SVU/HVU	2P, 3P	NV125-SVU/HVU	3P	32	75	86	-	-	-	32	Fig. 5
HLS-2SVU (*1)	NF250-SVU/HVU/CVU	3P	NV250-SVU/HVU/CVU	3P	-	84	100	-	-	-	-	Fig. 6
HLS-4SW (*3)	NF400-CW/SW/SEW/HEW/REW	2P, 3P, 4P	NV400-CW/SW/SEW/HEW	3P, 4P	-	-	-	-	-	-	-	Fig. 7
HLS-4UW (*3)	NF400-UW	3P	-	-	-	-	-	-	-	-	-	
HLS-8SW (*3)	NF800-CEW/SDW/SEW/HEW/REW	2P, 3P, 4P	NV800-SEW/HEW	3P, 4P	-	-	-	-	-	-	-	
HLS-8UW (*3)	NF400-UW	4P	-	-	-	-	-	-	-	-	-	
	NF800-UW	3P, 4P	-	-	-	-	-	-	-	-	-	

Notes \*1 For locking in OFF position  
 \*2 A, B, C and D in Figs. 5 and 6 are drilling sizes in front plate.  
 \*3 Terminal covers cannot be fitted.

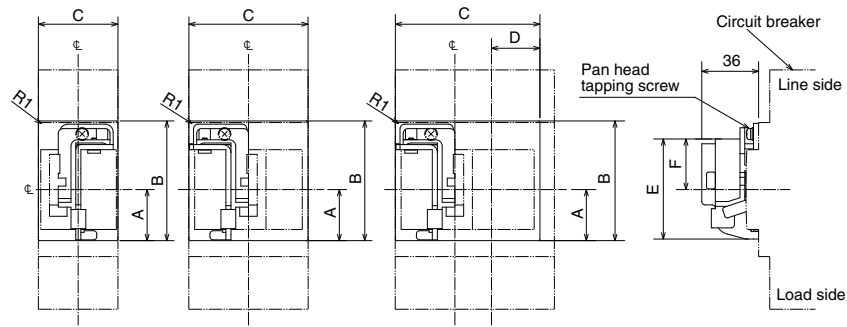

Fig. 5

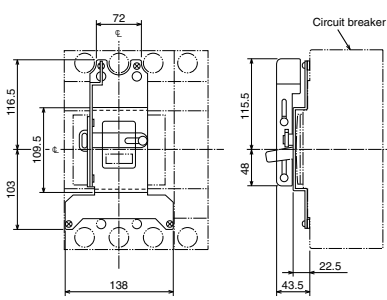

Fig. 6

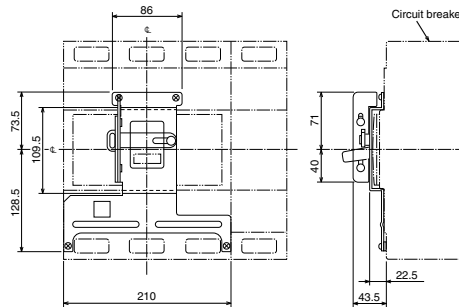

Fig. 7

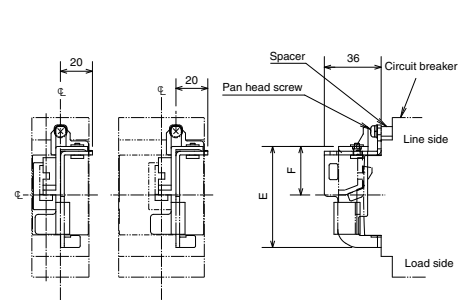
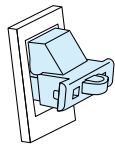

Fig. 8

## (2) Lock Covers (LC)

Lock Cover is a plug-in lock for indicating easily without using padlocks that it is prohibited to operate the circuit breaker. A "Caution" tag can be hung on it. The covers are red resin moldings.



LC03CS to LC-05SV

Table 6-37 LC

Type name	Applicable model	
	MCCB	ELCB
LC03CS	NF50/100-FHU	NV50/100-FHU
LC-05SV	NF32-SV	NV32-SV
	NF63-CV/SV/HV	NV63-CV/SV/HV
	NF125-CV/SV/HV/UV	NV125-CV/SV/HV
	NF125-SEV/HEV	NV125-SEV/HEV
	NF160-SGV/LGV/HGV/RGV	NV160-SGV/LGV/HGV/RGV
LC05FA	NF250-CV/SV/HV/UV	NV250-CV/SV/HV/UV
	NF250-SEV/HEV	NV250-SEV/HEV
	NF250-SGV/LGV/HGV/RGV	NV250-SGV/LGV/HGV/RGV

Remark: 1. One lot of and LC-NVL contains 50 pieces, and one lot of other models contains 10 pieces.

## (3) Auxiliary Handles (HT)

These handles facilitate opening and closing circuit breakers.

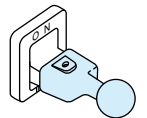

Auxiliary Handles

Table 6-38 HT

Type name	Applicable model	Dimensions					Outline dimension drawing
		A	B	C	D	E	
HT-4CW (*1)	NF400-CW, NV400-CW		77.5				
HT-4SW (*1) (*2)	NF400-SW/SEW/HEW/REW/UEW NF630-CW/SW/SEW/HEW/REW NF800-CEW/SDW/SEW/HEW NF800-REW/UEW	59	81	32	38	M4	
	NV400-SW/SEW/HEW NV630-CW/SW/SEW/HEW NV800-SEW/HEW						
HT-10SW (*3)	NF1000-SEW NF1250-SEW/SDW NF1600-SEW/SDW	62	118	34	45	M4	

Notes \*1 HT can be supplied separately. The user can fit it to the circuit breaker. (One lot contains 1 piece.)  
\*2 4-pole circuit breakers with 800A frame and 4-pole NF400-UEW come with auxiliary handles as standard accessories.  
\*3 HT is standard accessory.

## (4) Card Holders (CH)

Cards showing the circuit breaker name and circuit number can be inserted to the card holder.

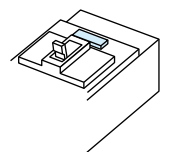

Fit the card holder to the circuit breaker body or the flush plate in the flush frame. (Although a card holder is supplied with each circuit breaker body, the card holder is available as an optional part.)

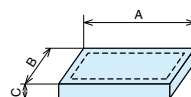

Table 6-39 Card holder size (mm)

Applicable model	Type name	A	B	C	Card size
NF250-SV or below NV250-SV or below	CH-P No.5	44	12	5	39x9
NF400-SW or above NV400-SW or above	CH-P No.3	38	22	5	33x20

## 7. Mechanical Interlocks (MI)

This mechanical interlock device is used to enable one of two circuit breakers to turn on. Install the device on the panel. Mechanical interlocks to be installed directly to circuit breaker bodies can be manufactured. Consult us for details.

### ● Front, rear and plug-in types

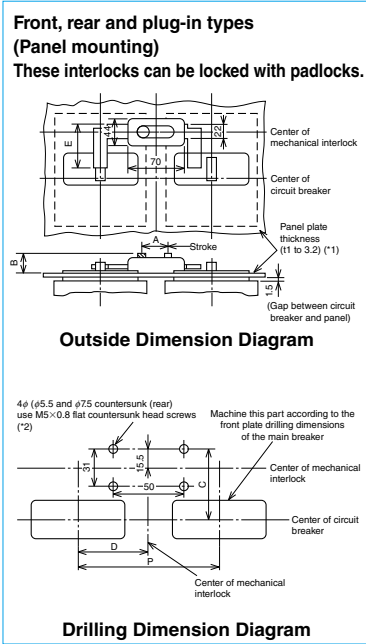

Fig. 1

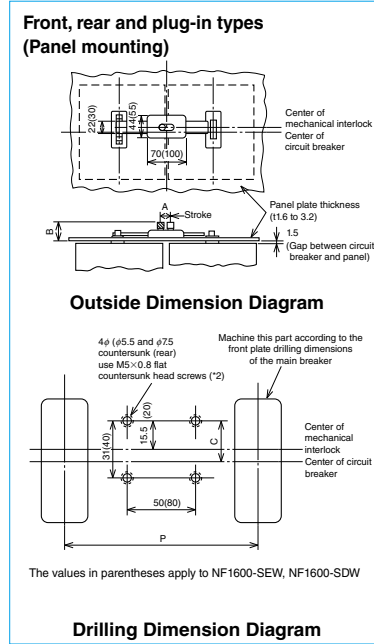

Fig. 2

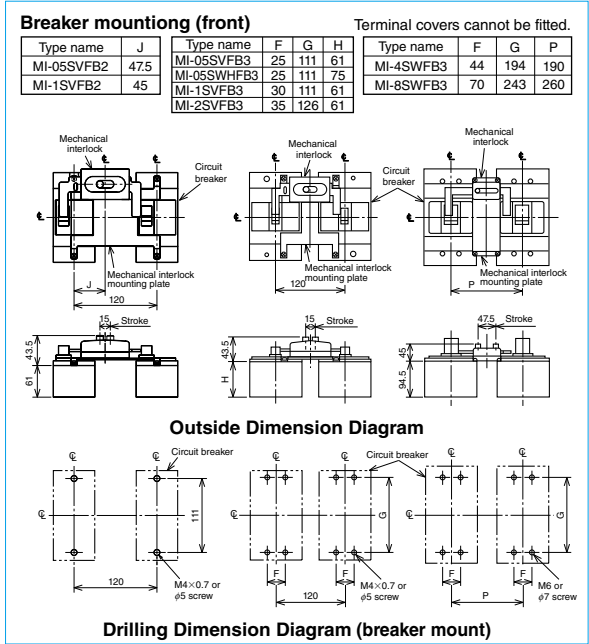

Fig. 3

Notes \*1 For 400A frame or above, use a panel 1.6 to 3.2 thick.  
\*2 When the panel is 2.3 or more thick, countersink the panel (rear side) in φ9.5 for the four φ5.5 holes.

Table 6-40 Table of variable dimensions

Applicable model		Pitch (P) (*1)					Dimensions (mm)					Reference diagram	Breaker mount (*3)	Reference diagram (3P)	
MCCB	ELCB	Standard		Semi-standard	Standard		t	A	B	C	D				E
		Type name	2P	3P	3P	Type name									
NF32-SV, NF63-CV/SV/HV	-	MI-05SV3	120	-	-	-	-	15	33	63	47.5	58	(Fig. 1)	MI-05SVFB2	(Fig. 3)
NF32-SV, NF63-CV/SV/HV	NV32-SV, NV63-CV/SV/HV		-	120	-	130		MI-05SV4	120 (*4)	15	33	63		-	
NF125-CV/SV	-	MI-05SV3	120	-	-	-	(*2)	15	33	63	45	58		MI-1SVFB2	
NF125-CV/SV/HV	NV125-CV/SV/HV		-	120	130	150		MI-1SV4	130 (*4)	15	33	63		-	
NF125-UV	-	MI-05SV3	120 (*4)	150	180	MI-2SV4	150 (*4)	15	33	63	-	58	(Fig. 1)	MI-2SVFB3	(Fig. 3)
NF125-SEV/HEV	NV125-SEV/HEV NV250-CV/SV/HV NV250-SEV/HEV														
NF125-SGV/LGV/HGV/RGV															
NF160-SGV/LGV/HGV															
NF250-CV/SV/HV, NF250-SEV/HEV NF250-SGV/LGV/HGV/RGV															
NF250-UV	-	MI-4SW3	190	-	210	MI-4SW4	250	-	47.5	33	83.5	-	74	MI-4SWFB3	(Fig. 3)
NF400-CW/SW/SEW/HEW/REW NF630-CW/SW/SEW/HEW/REW	NV400-CW/SW/SEW/HEW NV630-CW/SW/SEW/HEW														
NF400-UEW (3P)	-	MI-8SW3	220	-	240	MI-8SW4	290	-	47.5	33	60	-	74	MI-8SWFB3	
NF800-CEW/SDW/SEW/HEW/REW	NV800-SEW/HEW														
NF400-UEW (4P) NF800-UEW	-	MI-10SW3	220	-	-	MI-10SW4	290	2.3 (*5)	47.5	47	37.5	-	-	-	(Fig. 2)
NF1000-SEW, NF1250-SEW/SDW	-														
NF1600-SEW/SDW	-	MI-16SW3	315	-	-	MI-16SW4	426	-	65	54.5	39	-	-	-	



Notes \*1 Specify the circuit breaker mounting pitch (P).  
\*2 No need to specify the panel thickness (t). (Usable panel thickness range: t = 1~3.2mm. Above 400AF, use panel thickness t = 1.6~3.2mm)  
\*3 Terminal covers cannot be fitted. (However, TCL-4SW3 can be fitted.)  
\*4 When UVT is provided, separately install the module.  
\*5 If the thickness is not 2.3, specify the panel thickness (t).

Remarks 1. When a mechanical interlock is installed on the panel, screw type terminal covers cannot be installed.  
2. These devices do not provide an isolation function. However, 400, 600, 630 and 800A frame circuit breakers can be made conforming to it. (See Note 3.)  
3. On a 2-pole circuit breaker obtained by removing the neutral pole conductor from a 3-pole circuit breaker, the mechanical interlock can be installed in the same manner as on a 3-pole circuit breaker.

## 8. Boxes for Circuit Breakers and Boxed Circuit Breakers

### (1) Kinds and specifications

Table 6-41

		Closed type (S)	Dust-proof type (I)	Water-proof type (W)				
Appearance		 (*1)						
MCCB (*2)	NF32-SV, NF63-CV/SV/HV	2P 3P	NFS-05SV2 (*5) NFS-05SV	NFI-05SV	— NFW-05SV			
	NF125-CV/SV	2P 3P	NFS-1SV2 (*5)	NFI-1SV	— NFW-1SV			
	NF125-HV	2, 3P	NFS-1SV		NFW-1HV			
	NF125-SGV/LGV NF160-SGV/LGV NF250-SGV/LGV NF250-CV/SV, NF125/250-SEV	2, 3P	NFS-2SV	NFI-2SV	NFW-2SV			
	NF125/160/250-HGV NF250-HV, NF125/250-HEV		—					
	NF400-CW		—			NFI-4CW	NFW-4CW	
	NF400-SW/SEW		—			NFI-4SW	NFW-4SW	
	NF630-CW/SW/SEW		—			NFI-6SW	NFW-6SW	
	NF800-CEW/SDW/SEW		—			NFI-8SW	NFW-8SW	
	NV32-SV, NV63-CV/SV/HV		2P 3P			NFS-05SV NFS-05SV	NFI-05SV	— NFW-05SV
	NV125-CV/SV NV125-HV		3P			NFS-1SV NFS-1SV	NFI-1SV	NFW-1SV NFW-1HV
	NV250-CV/SV, NV125/250-SEV NV250-HV, NV125/250-HEV	NFS-2SV		NFI-2SV	NFW-2SV			
NV400-CW	—	NFI-4CW		NFW-4CW				
NV400-SW/SEW	—	NFI-4SW		NFW-4SW				
NV630-CW/SW/SEW	—	NFI-6SW		NFW-6SW				
NV800-SEW	—	NFI-8SW		NFW-8SW				
Operating method		Direct operation of circuit breaker handle	Operation through operating handle mechanism					
Standard paint color		Box: Munsell 5Y7/1 Operating handle: Munsell N1.5						
Protection class (IEC 60529)		IP3X	IP4X (*3)	IP65 (*4)				

Notes \*1 The window frame varies depending on the model.  
 \*2 For 1-pole circuit breakers, boxes are not manufactured.  
 \*3 The protection class of NFI-1SV and NFI-2SV is IP3X.  
 \*4 The protection class of NFW-4CW, NFW-4SW, NFW-6SW and NFW-8SW is IP54.  
 \*5 The circuit breaker body is a 2-pole external type.

Remarks: 1. Only internal accessories with lead wires drawn out can be fitted. (However, LT and SLT can be fitted on the right pole side.)  
 2. The dust-proof type (I) models do not provide an isolation function.

#### ● Selection of rated current

When selecting the rated current of circuit breaker, it is necessary to consider the temperature in the box. When the rated current is carried, the temperature in the box increases by 10 to 20K. Correct the rated current with the temperature correction curve.

Determine the maximum working current to be 80% or less of the rated current.

#### ● Locking

Type I and W boxed circuit breakers can be provided with locks in the following parts. Locking can prevent unnecessary operation.

- ① Cover and case
- ② ON or OFF position of operating handle  
 ( Padlocks must be prepared by the user.  
 ( The dimensions of the padlocks are shown )  
 on page 116. )

#### ● Interlock (only for Dust-proof type)

The cover cannot be opened while the circuit breaker is in the ON state. However, if the interlock release screw is turned, the cover is released from the locked state and can be opened even in the ON state.

#### ● Handle operation and display

The ON, OFF or trip state of the body is displayed on each position on the decorative board.

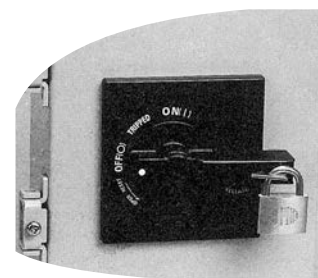

Example of Type I operating handle block

## (2) External dimensions

### MCCB

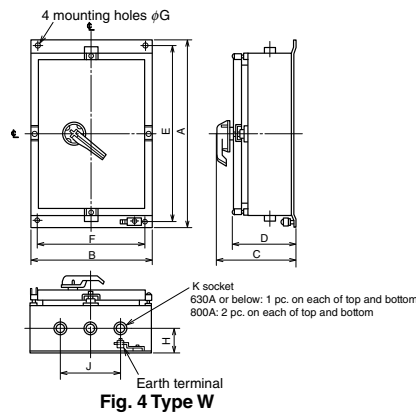
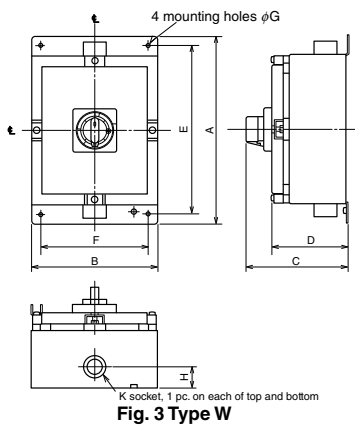
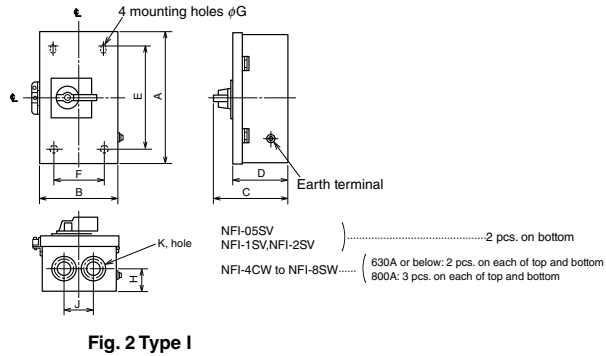
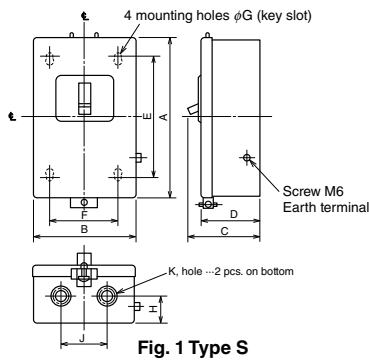
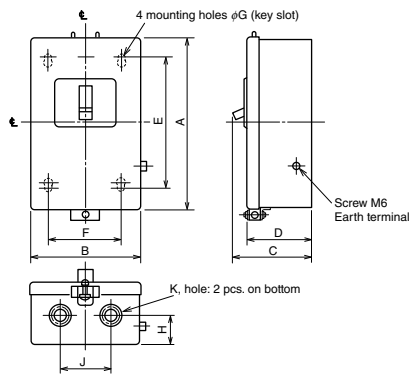

**Table 6-42 Table of variable dimensions (Boxes for 4-pole circuit breakers are not manufactured.)**

Box type	Type name	Applicable Model	Variable dimensions (mm)										
			Fig.	A	B	C	D	E	F	G	H	J	K
S	NFS-05SV2	NF32-SV, NF63-CV/SV/HV	1	260	178	98	78	202	100	7	34	100	28, 35, 44
	NFS-05SV		1	310	178	98	78	252	100	7	34	100	28, 35, 44
	NFS-1SV2	NF125-CV/SV											
	NFS-1SV	NF125-CV/SV/HV											
NFS-2SV	NF250-CV/SV, NF125/250-SEV NF125-SGV/LGV NF160-SGV/LGV NF250-SGV/LGV	1	440	247	137	116	373	170	9	52	120	50, 62, 78	
I	NFI-05SV	NF32-SV, NF63-CV/SV/HV	2	350	186	155.5	117	286	120	7	42	100	28, 35, 44
	NFI-1SV	NF125-CV/SV/HV	2	352	188	155.5	118	286	120	7	42	100	28, 35, 44
	NFI-2SV	NF250-CV/SV/HV, NF125/250-SEV/HEV NF125-SGV/LGV/HGV NF160-SGV/LGV/HGV NF250-SGV/LGV/HGV	2	442	248	162	124	373	170	9	54	120	50, 62, 78
	NFI-4CW	NF400-CW	2	730	320	244	191	650	240	11	87	120	50, 62, 78
	NFI-4SW	NF400-SW/SEW	2	730	320	244	191	650	240	11	65	120	50, 62, 78
	NFI-6SW	NF630-CW/SW/SEW	2	940	433	260	207	856	350	15	90	150	92
	NFI-8SW	NF800-CEW/SDW/SEW	2	1353	543	304	251	1270	460	15	90	320	104
W	NFW-05SV	NF32-SV, NF63-CV/SV/HV	3	390	265	214	160	350	225	9.5	45	-	28
	NFW-1SV	NF125-CV/SV	3	390	265	214	160	350	225	9.5	50	-	36
	NFW-1HV	NF125-HV	3	480	265	239	186	440	225	9.5	60	-	36
	NFW-2SV	NF250-CV/SV/HV, NF125/250-SEV/HEV NF125-SGV/LGV/HGV NF160-SGV/LGV/HGV NF250-SGV/LGV/HGV	3	550	355	264	210	510	315	11	75	-	54
	NFW-4CW	NF400-CW	4	800	355	257	220	760	315	11	85	-	70
	NFW-4SW	NF400-SW/SEW	4	800	355	257	220	760	315	11	85	-	70
	NFW-6SW	NF630-CW/SW/SEW	4	800	355	257	220	760	315	11	85	-	82
	NFW-8SW	NF800-CEW/SDW/SEW	4	1435	550	339	265	1395	515	15	100	180	104

(Note) The sockets are applicable to thick steel duct (JIS C 8305) and conduit tube thread.

**ELCB**



**Fig. 1 Type S**

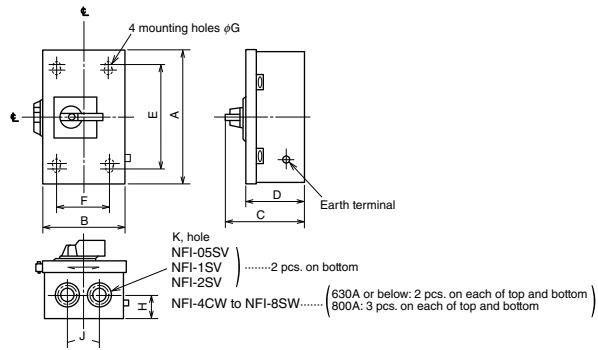

**Fig. 2 Type I**

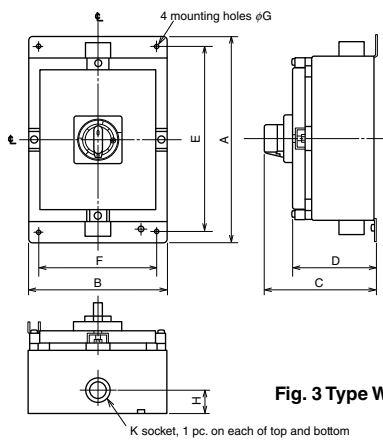

**Fig. 3 Type W**

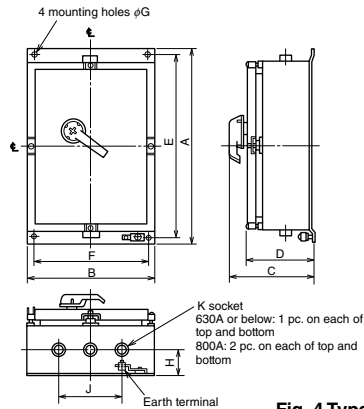

**Fig. 4 Type W**

**Table 6-43 Table of variable dimensions (Boxes for 4-pole circuit breakers are not manufactured.)**

Box type	Type name	Applicable Model	Variable dimensions (mm)										
			Fig.	A	B	C	D	E	F	G	H	J	K
S	NFS-05SV	NV32-SV, NV63-CV/SV/HV	1	260	178	98	78	202	100	7	34	100	28, 35, 44
	NFS-1SV	NV125-CV/SV/HV	1	310	178	98	78	252	100	7	34	100	28, 35, 44
	NFS-2SV	NV250-CV/SV, NV125/250-SEV	1	440	247	137	116	373	170	9	52	120	50, 62, 78
I	NFI-05SV	NV32-SV, NV63-CV/SV/HV	2	350	186	155.5	117	286	120	7	42	100	28, 35, 44
	NFI-1SV	NV125-CV/SV/HV	2	352	188	155.5	118	286	120	7	42	100	28, 35, 44
	NFI-2SV	NV250-CV/SV/HV, NV125/250-SEV/HEV	2	442	248	162	124	373	170	9	54	120	50, 62, 78
	NFI-4CW	NV400-CW	2	730	320	244	191	650	240	11	87	120	50, 62, 78
	NFI-4SW	NV400-SW/SEW	2	730	320	244	191	650	240	11	65	120	50, 62, 78
	NFI-6SW	NV630-CW/SW/SEW	2	940	433	260	207	856	350	15	90	150	92
	NFI-8SW	NV800-SEW	2	1353	543	304	251	1270	460	15	90	320	104
W	NFW-05SV	NV32-SV, NV63-CV/SV/HV	3	390	265	214	160	350	225	9.5	45	-	28
	NFW-1SV	NV125-CV/SV	3	390	265	214	160	350	225	9.5	50	-	36
	NFW-1HV	NV125-HV	3	480	265	239	186	440	225	9.5	60	-	36
	NFW-2SV	NV250-CV/SV/HV, NV125/250-SEV/HEV	3	550	355	264	210	510	315	11	75	-	54
	NFW-4CW	NV400-CW	4	800	355	257	220	760	315	11	85	-	70
	NFW-4SW	NV400-SW/SEW	4	800	355	257	220	760	315	11	85	-	70
	NFW-6SW	NV630-CW/SW/SEW	4	800	355	257	220	760	315	11	85	-	82
NFW-8SW	NV800-SEW	4	1435	550	339	265	1395	515	15	100	180	104	

Note) The sockets are applicable to thick steel duct (JIS C 8305) and conduit tube thread.

## 9. Electrical Operated Circuit Breakers and Electrical Operation Devices



Spring charge type (1)



Spring charge type (2)  
Standard paint color: Munsell 5Y7/1



Motor-drive type (2)  
Standard paint color: Munsell 5Y7/1

### (1) Specifications

#### ● Electrically operated circuit breakers

Table 6-44

Specify the electrical operation device together with the circuit breaker body.

Electrically operating method		Spring charge type (1)	Spring charge type (2)		Motor-drive type (2)			
MCCB	Class S, H and R	NF125-SV, NF125-HV NF125-SEV, NF125-HEV NF125-SGV/LGV/HGV/RGV NF160-SGV/LGV/HGV NF250-SV, NF250-HV NF250-SEV, NF250-HEV NF250-SGV/LGV/HGV/RGV NF125-RV, NF250-RV	NF400-SW, NF400-SEW NF400-HEW, NF400-REW NF630-SW, NF630-SEW NF630-HEW, NF630-REW NF800-SDW, NF800-SEW NF800-HEW, NF800-REW	NF1000-SEW NF1250-SEW NF1250-SDW NF1600-SEW NF1600-SDW	NF400-SW, NF400-SEW NF400-HEW, NF400-REW NF630-SW, NF630-SEW NF630-HEW, NF630-REW NF800-SDW, NF800-SEW NF800-HEW, NF800-REW	NF1000-SEW NF1250-SEW NF1250-SDW NF1600-SEW NF1600-SDW		
	Class C	NF125-CV NF250-CV	NF400-CW NF630-CW NF800-CEW	-	NF400-CW NF630-CW NF800-CEW	-		
	Class U	NF125-UV NF250-UV	NF400-UEW NF800-UEW	-	NF400-UEW NF800-UEW	-		
	Motor breakers	NF125-SV, NF250-SV	-	-	-	-		
ELCB	Class S, H and R	NV125-SV, NV125-HV NV125-SEV, NV125-HEV NV250-SV, NV250-HV NV250-SEV, NV250-HEV	NV400-SW, NV400-SEW NV400-HEW NV630-SW, NV630-SEW NV630-HEW, NF800-SEW NV800-HEW	-	NV400-SW, NV400-SEW NV400-HEW NV630-SW, NV630-SEW NV630-HEW, NF800-SEW NV800-HEW (*3)	-		
	Class C	NV125-CV NV250-CV	NV400-CW NV630-CW	-	NV400-CW(*3) NV630-CW	-		
	Motor breakers	NV125-SV, NV250-SV	-	-	-	-		
	Rated operating voltage (V) (Allowable operating voltage range: 85 to 110%)		Compatible with 100 to 240VAC and 100 to 250VDC 24VDC, 48 to 60VDC (*1)	100-110VDC, 100-110VAC 200-220VAC(125VDC, 240VAC)		100-110VDC, 100-110VAC, 200-220VAC (125VDC, 240VAC)		
Operating current (Arms) Values in ( ): Starting current	DC	100/110V	ON OFF	0.5 (1.5)	8 1.0 (3.0)	10 1.0 (4.0)	3.0(8.0) 5.0(13.5)	
		100/110V	ON OFF	0.6 (3.0)	10 1.0 (3.0)	10 1.0 (3.0)	4.0(8.0) 5.0(10.0)	
	AC	200/220V	ON OFF	0.5 (2.5)	0.5 (1.5)	8 0.5 (1.5)	8 0.5 (1.5)	2.0(4.5) 3.5(7.0)
		Operating time	ON	0.05-0.1(*2)	0.05	0.07	0.3 or less (self-holding type)	
	OFF	0.6 or less (self-holding type)	3 or less (self-holding type)					
	Charge	1.2 or less (self-holding type)						
Required transformer capacity VA		150	700		400	700		
Endurance voltage		1500V	1500V					

Notes \*1 When the rated operating voltage is 24VDC or 48 to 60VDC, specify the voltage. If the voltage is not specified, the circuit breaker will be manufactured for 100 to 240VAC and 100 to 250VDC.

\*2 For 24VDC circuit breakers, the operating time at a voltage of 100% or more is shown.

\*3 Models for special voltage (125VDC or 240VAC) are not provided with the test button.

\*4 These are examples of operating current values, and are not guaranteed values.

Remarks 1. Flush plate type circuit breakers can be manufactured to order.

2. The models with voltage in parentheses are special voltage products.

3. For the spring charge type (1), use an ON-OFF operating switch for minute load.

4. For the spring charge type (1) The circuit breaker of 3 pole can be used TC-S, TC-L, TTC, BTC and PTC.

In case of 125A frame 4 pole can be used only TC-L.

In case of 250A frame 4 pole can be used TC-S, TC-L, TTC, BTC and PTC.

5. When the body of the spring charge type (1) breaker is an earth leakage alarm breaker, the reset button cannot be pressed. Provide such a circuit breaker with an external reset or automatic reset system (except for the electronic type).

6. When the body of the motor-drive type (2) or spring charge type (2) has internal accessories, they are normally provided with lead wire terminal blocks.

7. The types other than the spring charge type (1) do not provide an isolation function.

8. When placing an order for a CE marked product of the spring charge type (1) or spring charge type (2), specify the model name with CE.

9. The switching durability of electrically operated circuit breakers conforms to JIS.

#### ● Electrical operation devices

The following models of Electrical Operation Devices are supplied also as separate devices. The user can install them to the circuit breaker body.

(Front connection, rear connection and plug-in types)

(When requiring a motor breaker or a CE marked product, place an order for it together with the circuit breaker body.)

Table 6-45

Electrically operating method	Spring charge type (1)				
	Applicable models	NF125-CV/SV/HV	NV125-CV/SV/HV	NF125-SEV/HEV/SGV/LGV/HGV/RGV NF160-SGV/LGV/HGV NF250-CV/SV/HV/UV/SEV/HEV/SGV/LGV/HGV/RGV NF250-UV	NV250-CV/SV/HV
Rated operating voltage					
Compatible to 100-240VAC/100-250VDC	MDSAD240-NF1SVE	MDSAD240-NV1SVE	MDSAD240-NF2SVE	MDSAD240-NV2SVE	MDSAD240-NVE2SVE
24VDC	MDS024-NF1SVE	MDS024-NV1SVE	MDS024-NF2SVE	MDS024-NV2SVE	MDS024-NVE2SVE
48-60VDC	MDS060-NF1SVE	MDS060-NV1SVE	MDS060-NF2SVE	MDS060-NV2SVE	MDS060-NVE2SVE

**● Cautions**

- All electrical operations are based on intermittent rating. Avoid operating any device continuously 10 times or more (ON and OFF operations are counted as one time).
- Operate any device at 85 to 110% of the rated operating voltage.
- The dielectric strength of electrical operation circuits is 1500 V. When performing dielectric strength test of any of these devices and other devices, if the test voltage exceeds the rated value (1500V), disconnect the operation power supply terminal.
- When collectively operating more than one electrical operation device, isolate the devices connecting a relay to each device.  
If the control terminals are directly connected in parallel, a circuit will be formed, and the devices may not normally function.

**● Automatic reset (optional)**

The automatic reset type has a built-in alarm switch in the circuit breaker and is connected in such a way that the OFF operation circuit is closed when the circuit breaker trips. Therefore, when the circuit breaker trips, it is automatically reset.

However, when the circuit breaker thermally trips, it may not be automatically reset.

If an automatic reset spring charge type (1) is required, the user must wire the device in accordance with the external connection diagram shown in Fig. 1 in "Cautions for use" in (2).

**(2) Structure and operation**

**■ Spring charge type (1)**

**● Electrical operation**

- When the ON operation switch is closed, the relay will operate, the motor will be driven, the latch mechanism will be released, and the closing spring force will instantaneously turn on the circuit breaker.
- When the OFF operation switch is closed, the relay will operate, the motor will be driven, the circuit breaker will be turned off (reset), and, at the same time, the closing spring will be charged.

Note: The charge may not be completed because the circuit protective function operates.

**● Manual operation**

- After turning the MANUAL/AUTO selection switch on the cover upper surface to MANUAL, press the ON button, and the latch mechanism will be released, and the closing spring force will instantaneously turn on the circuit breaker.
- After turning the MANUAL/AUTO selection switch on the cover upper surface to MANUAL, draw out the manual handle, and move it upward and downward about 10 to 14 times. Then, the circuit breaker will be turned off (reset), and, at the same time, the closing spring will be charged. Although the circuit breaker can be turned off even if the switch is not turned to MANUAL, the selection switch should be set to MANUAL because remote operation may be accepted.
- After turning the changeover switch to MANUAL, draw out the OFF lock plate, and lock the circuit breaker in the OFF state with padlocks (to be prepared by the user). Up to three padlocks can be fitted.  
φ5 to φ8 padlocks can be fitted.

Note: After the completion of manual operation (on-site operation), return the selection switch to AUTO without fail. If it is not returned, electrical operation (remote operation) cannot be performed.

**● Display of tripping state**

When the circuit breaker trips in the ON state, the tripping state is displayed. When it trips in the OFF state, the OFF state is kept displayed.

Note: When it trips in the OFF state, signals from AL will not be output.

**● Cautions for use**

- ① To the ON or OFF operation switch (to be prepared by the user), current only of 24VDC and 15 to 30mA flows. Use a switch for minute load.
- ② Operate the operation switch for 0.1s or more to turn on and for 20ms or more to turn off. If it is operated for less than the time, it may not function.  
The wire to the operation switch shall be less than 100m.
- ③ The power supply module has a built-in switching power supply. Therefore, it may interfere with communication devices near the module. In such a case, install a noise filter on the input side.
- ④ For the automatic reset type, purchase a circuit breaker with alarm switch (for minute load), and connect the signal circuit (among the terminal numbers S1, S2 and S4) as shown in Fig. 1. Please note that the wirings that are shown in dashed lines are wired already at the time of shipment from the factory.

If the circuit breaker in the OFF state is tripped by UVT-N or the like, it cannot be automatically reset. To reset it, it is necessary to turn it on under no current. After this operation, it will be automatically reset.

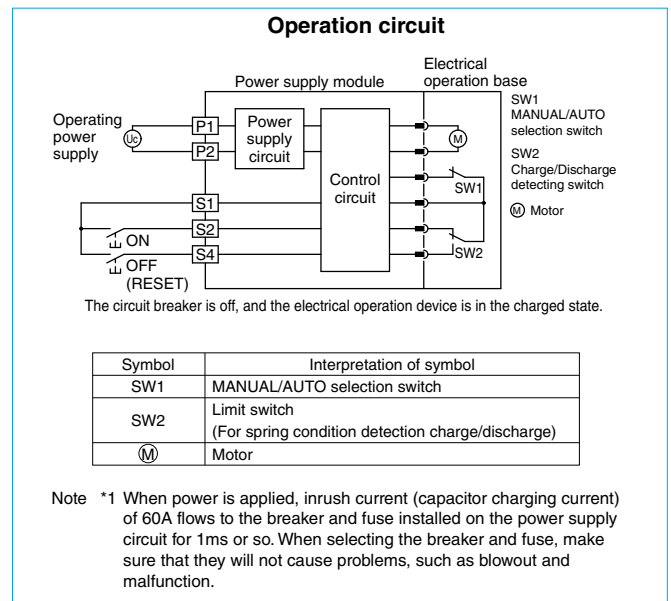
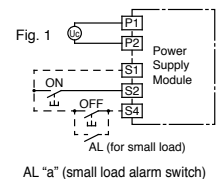

**■ Motor-drive type (2)**

**● Electrical operation**

Forward and reverse motor rotation is changed by ball screw to switch the breaker ON and OFF (reset).

**● Manual operation**

The manual operation handle can be used to switch the breaker ON and OFF directly.

# 6 Accessories 2 External Accessories

## ● Cautions for use

- In the case of a circuit breaker with UVT, if the circuit breaker trips owing to the operation of UVT, the procedure for re-closing the circuit breaker varies depending on the condition of the electrical operation device before the circuit breaker trips.
  - Tripping in ON state: Reset (OFF). → Turn on.
  - Tripping in OFF state: Turn on (idle tripping). → Reset (OFF). → Turn on.
 (If the circuit breaker cannot be turned on (idle tripping), reset (OFF) it, and turn on.)
  - When an automatic reset system is configured on a non-reset type circuit breaker with UVT, if UVT is set to the no-voltage state, the operations to turn off (reset), trip, turn off (reset) and trip are repeated. Therefore, configure the circuit in such a way that power is disconnected from the electrical operation device before the circuit breaker is tripped by the non-reset type UVT.
- Current of about 0.2A will flow to the ON-OFF switch. Use an appropriate switch.

- Do not apply ON and OFF operation signals continuously. An interval of 0.5 sec or more is necessary between ON and OFF signals.
- In the case of the automatic reset type device, it will perform the reset operation with an interval of 0.5 sec after NFB performs the tripping action.
- The electrical operation device has a built-in pumping preventing circuit. Therefore, it can operate to turn off the circuit breaker while the ON operation switch is held in the closing state, but it cannot turn on continuously after turning off. To turn on, once turn off the ON operation switch, and turn on the switch. Do not apply the ON operation signal continuously.
- The manual operating handle moves at a high speed during electrical operation. Pay attention to the handle. Keep the operation circuit power supply off during manual operation.
- In the manual operation, surely turn the manual operating handle to the position indicated on the nameplate.

● **Operation circuit** ---- For the automatic reset type, the connections indicated with the dashed lines are added.

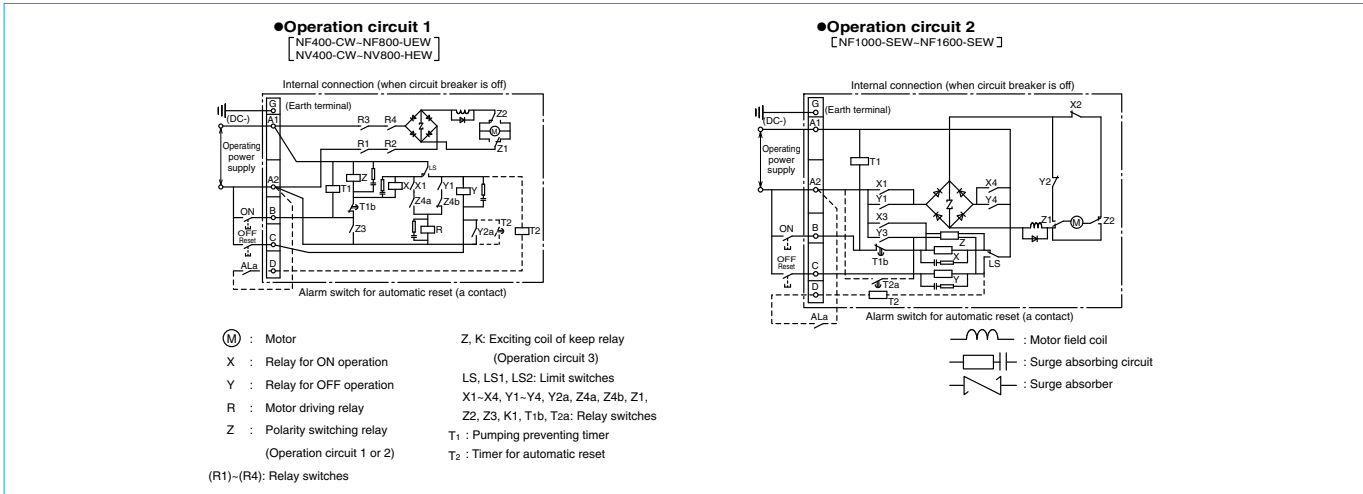

## ■ Spring charge type (2)

### ● Electrical operation

When the ON operation switch is closed, the closing coil will be excited to release the latch mechanism, and the closing spring force will instantaneously turn on the circuit breaker. When the OFF operation switch is closed, the relay will operate to start the motor, turn off (reset) the circuit breaker and, at the same time, charge the closing spring.

### ● Manual operation

- Press the ON button, and the latch mechanism will be released, and the closing spring force will instantaneously turn on the circuit breaker.
- Turning off (resetting)  
Push the leaf spring, bring out the manual handle, and move the handle upward and downward more than ten times. Then, the circuit breaker will be turned off (reset), and, at the same time, the closing spring will be charged.

### ● Cautions for use

- Before installing or removing the electrical operation device to or from the circuit breaker, trip the circuit breaker, and discharge the electrical operation device. After the device is installed to the circuit breaker, the device will not trip the circuit breaker in the OFF state even if the trip button is pressed. This is not a trouble. The electrical operation device takes 3 seconds to turn off the circuit breaker. To open the circuit immediately by remote operation, use a circuit breaker with SHT or UVT. The device has a built-in pumping preventing relay.
- Current of about 9A and 0.2A will flow to the ON and OFF switches, respectively. Use appropriate switches.

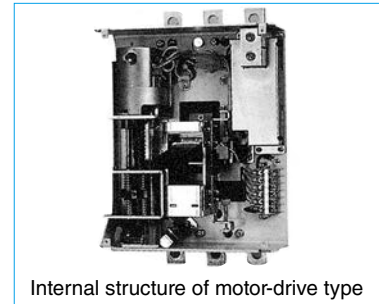
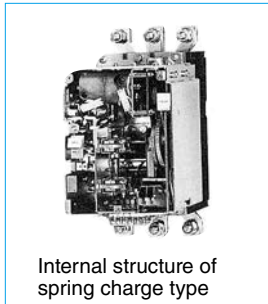

### ● Operation circuit

For the automatic reset type, the connections indicated with the dashed lines are added.

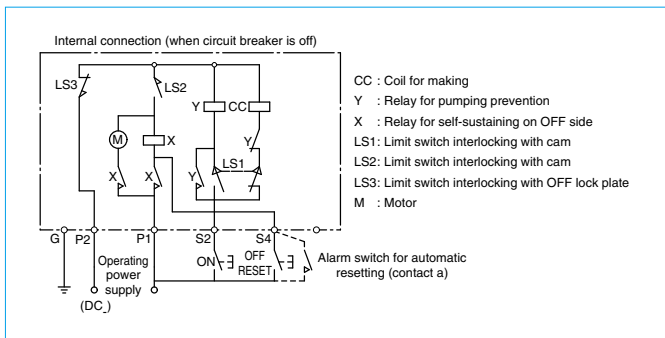

## 10. IEC 35mm Rail Mounting Adapters

**Table 6-46**

Type name	Number of poles of circuit breaker	Applicable model	
		MCCB	ELCB
(Note1) DIN-05SV	2, 3	NF32-SV NF63-CV/SV/HV	NV32-SV NV63-CV/SV/HV

Note : 1. Place an order in units of 10 pieces.

### ● External dimension

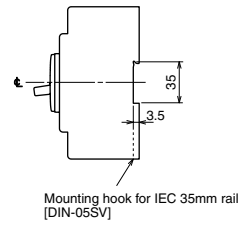



# 7

## Characteristics and Dimensions

### **1 Molded Case Circuit Breakers 146**

• NF32-SV, NF63-CV/SV/HV .....	146
• NF125-CV/SV/HV .....	148
• NF125-UV .....	150
• NF250-CV/SV/HV .....	152
• NF250-UV .....	154
• NF125-SGV/LGV/HGV/RGV, NF160-SGV/LGV/HGV, NF250-SGV/LGV/HGV/RGV .....	156
• NF125-SEV/HEV, NF250-SEV/HEV .....	158
• NF400-CW/SW .....	160
• NF400-SEW/HEW/REW .....	162
• NF400-UEW .....	164
• NF630-CW/SW .....	166
• NF630-SEW/HEW/REW .....	168
• NF800-CEW/SEW/HEW/REW .....	170
• NF800-SDW .....	172
• NF800-UEW .....	174
• NF1000-SEW, NF1250-SEW .....	176
• NF1250-SDW .....	178
• NF1600-SEW .....	180
• NF1600-SDW .....	182

### **2 Earth Leakage Circuit Breakers 184**

• NV32-SV, NV-63CV/SV/HV .....	184
• NV125-CV/SV/HV .....	186
• NV250-CV/SV/HV .....	188
• NV125-SEV/HEV, NV250-SEV/HEV .....	190
• NV400-CW/SW .....	192
• NV400-SEW/HEW .....	194
• NV630-CW/SW .....	196
• NV630-SEW/HEW .....	198
• NV800-SEW/HEW .....	200

### **3 UL Certified Circuit Breakers 202**

• NF50-SMU .....	202
• NF50-SVFU, NV50-SVFU .....	204
• NF100-CVFU, NV100-CVFU .....	206
• NF100-SRU/HRU, NV100-SRU/HRU .....	208
• NF125-SVU/HVU, NV125-SVU/HVU .....	210
• NF250-CVU/SVU/HVU, NV250-CVU/SVU/HVU .....	212
• NF400-SWU/HWU .....	214
• NF630-SWU/HWU .....	216
• NF30-FAU, NF50-FAU, NV30-FAU, NV50-FAU .....	218
• NF50-FHU, NF100-FHU, NV50-FHU, NV100-FHU .....	220

### **4 Measuring Display Unit Breakers 222**

• NF250-SEV/HEV with MDU .....	222
• NF400-SEW/HEW with MDU .....	224
• NF800-SEW/HEW with MDU .....	226

### **5 DC High-Voltage Circuit Breakers 230**

• NF63-HDV .....	230
• NF125-HDVA, NF250-HDVA .....	232
• NF400-HDW, NF800-HDW .....	234

### **6 Miniature Circuit Breakers, Residual Current Circuit Breakers, Residual Current Circuit Breakers with Overcurrent Protection and Isolating Switches 236**

• BH-D6, BH-D10 .....	236
• BH-DN .....	237
• BV-D .....	238
• BV-DN, BV-DN6 .....	239
• KB-D .....	240

### **7 Circuit Protectors 241**

• CP30-BA/HU .....	241
--------------------	-----

### **8 Electrical Operated Circuit Breakers 242**

# 7 Characteristics and Dimensions

## Molded Case Circuit Breakers

NF32-SV  
NF63-CV  
NF63-SV  
NF63-HV



NF63-SV

Model	NF32-SV	NF63-CV	NF63-SV	NF63-HV	NF32-SV [MB]	NF63-CV [MB]	NF63-SV [MB]		
Rated current In (A) Reference ambient temperature 40°C	3 4 (5) 6 10 (15) 16 20 25 (30) 32	3 4 (5) 6 10 (15) 16 20 25 (30) 32 40 50 (60) 63	3 4 (5) 6 10 (15) 16 20 25 (30) 32 40 50 (60) 63	10 (15) 16 20 25 (30) 32 40 50 (60) 63	4 5 7.1 8 10 12 16 25	4 5 7.1 8 10 12 16 25 32 40 45	4 5 7.1 8 10 12 16 25 32 40 45		
Number of poles	2 3	2 3	2 3 4	2 3 4	3	3	3		
Rated insulation voltage Ui (V)	600	600	600	690	500	500	500		
Rated short-circuit breaking capacity (kA)	IEC 60947-2 EN 60947-2 (Icu/Ics)	AC	690V	–	–	–	–	–	
			500V	2.5/2.5	2.5/2.5	7.5/7.5	7.5/7.5	–	–
			440V	2.5/2.5	2.5/2.5	7.5/7.5	10/8	2.5/2.5	2.5/7.5
			415V	2.5/2.5	2.5/2.5	7.5/7.5	10/8	2.5/2.5	7.5/7.5
			400V	5/5	5/5	7.5/7.5	10/8	5/5	7.5/7.5
			380V	5/5	5/5	7.5/7.5	10/8	5/5	7.5/7.5
			230V	7.5/7.5	7.5/7.5	15/15	25/19	7.5/7.5	15/15
			200V	7.5/7.5	7.5/7.5	15/15	25/19	–	–
DC	250V (*1)	2.5/2.5	2.5/2.5	7.5/7.5	–	–	–		
Standard attached parts (front connection)	Terminal screw: 50A or less M5×14 (2P: 4pcs, 3P: 6pcs, 4P: 8pcs) 60A or more M8×14 (2P: 4pcs, 3P: 6pcs, 4P: 8pcs) Mounting screw: M4×0.7×55 (2 and 3P: 2pcs, 4P: 4pcs) Insulation barrier: (2P: 1pc, 3P: 2pcs, 4P: 3pcs) (*2)								

Notes \*1 Use two poles for three- and four-pole products. Not available for use with connection as shown at the bottom of page 18.  
\*2 Supplied with NF63-SV and NF63-HV.

### Operating Characteristics

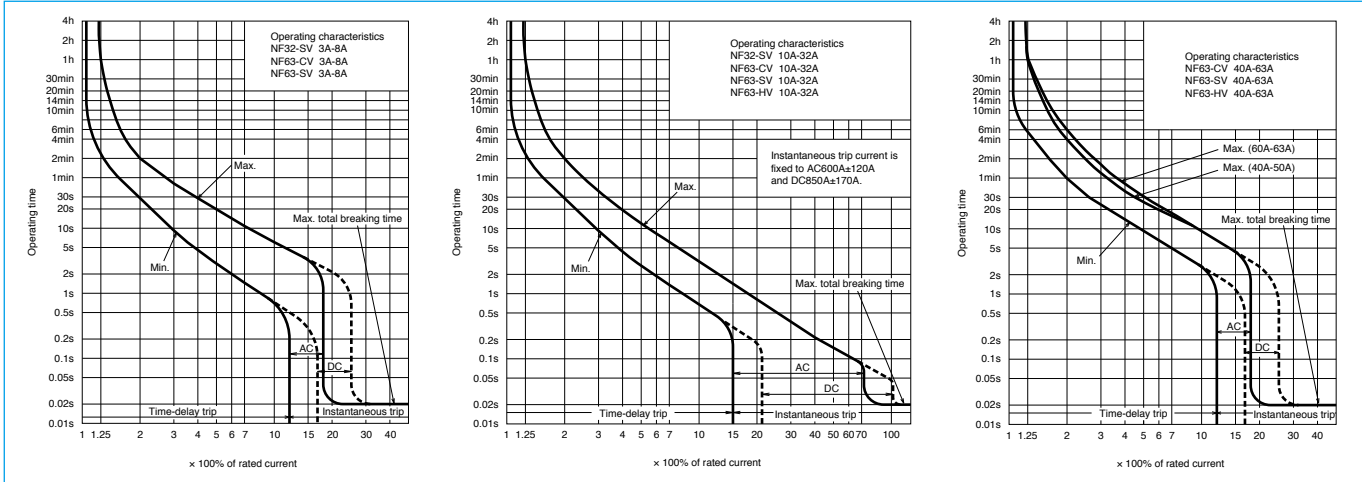

### Internal Accessories

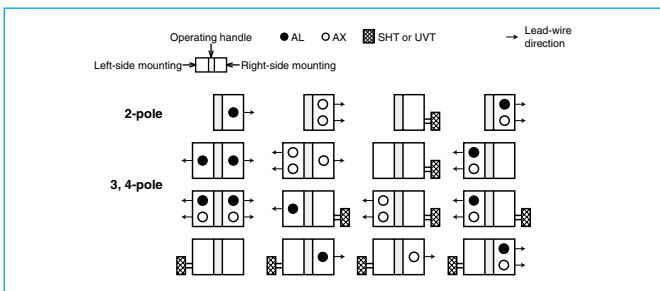

### Temperature Compensation Curve

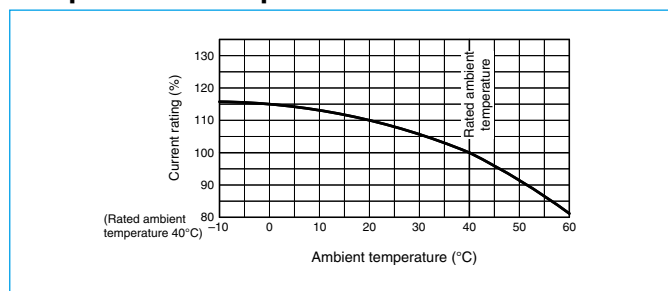

### External Accessories

Accessories	Type name	Reference page	Accessories	Type name	Reference page	
Operating handle	F 2P	F-05SV2	Small	TC-S 2P	TCS-05SV2	
	3, 4P	F-05SV		3P	TCS-05SV3	
	V 2P	V-05SV2		4P	TCS-05SV4	
	3, 4P	V-05SV		2P	TCL-05SV2	
Lock cover	LC	LC-05SV	Large	TC-L 2P	TCL-05SV2L	
Handle lock device	HL(*1)	HLF-05SV		3P	TCL-05SV3	
	HL-S	HLN-05SV		4P	TCL-05SV3L	
	HL-S	HLS-05SV		2P	TTC-05SV2	
Mechanical interlock	MI 2, 3P	MI-05SV3	Skeleton	TTC 2P	TTC-05SV2	
	3, 4P	MI-05SV4		3P	TTC-05SV3	
Terminal cover				Rear	BTC 2P	BTC-05SV2
					3P	BTC-05SV3
			4P		BTC-05SV4	
			Plug-in		PTC	
3P	PTC-05SV3					
4P	PTC-05SV4					
IEC 35mm rail mounting adapters	DIN-05SV	143				

Note \*1 HLF types are used for OFF lock and HLN types for ON lock.

Outline Drawing

Front connection

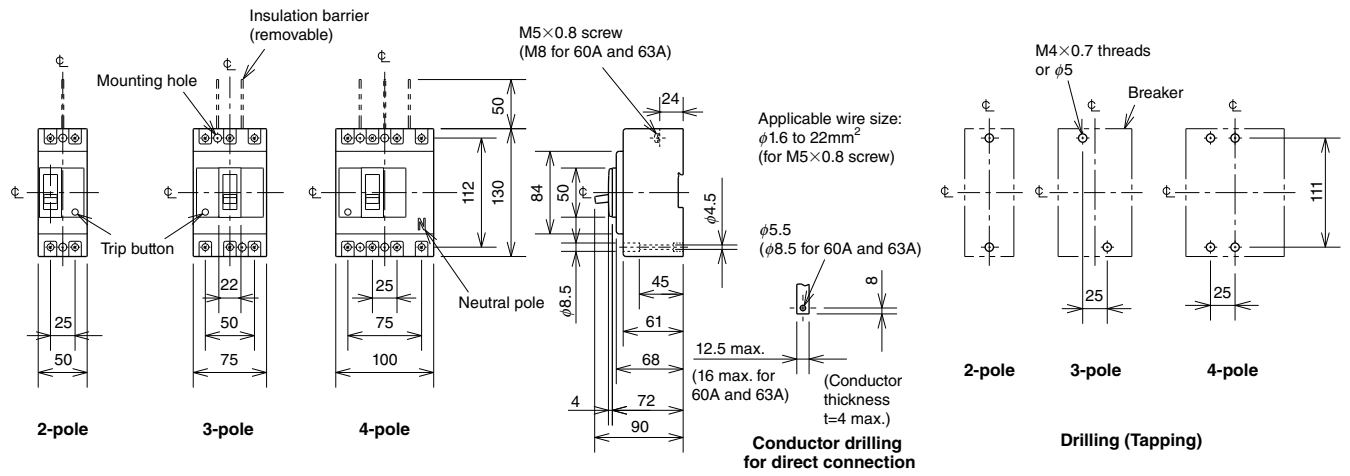

Rear connection

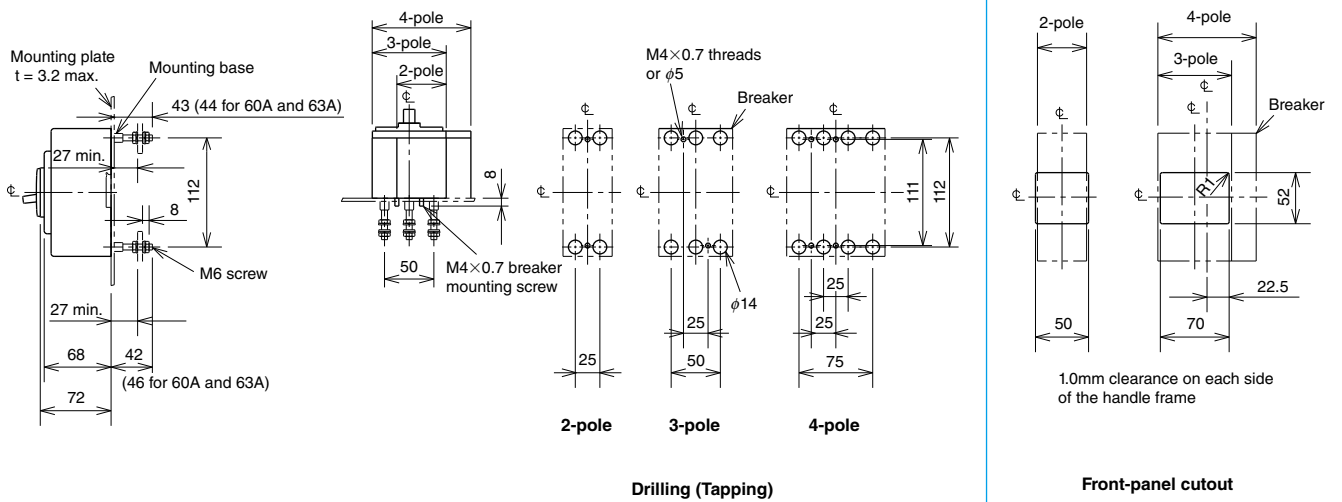

Plug-in

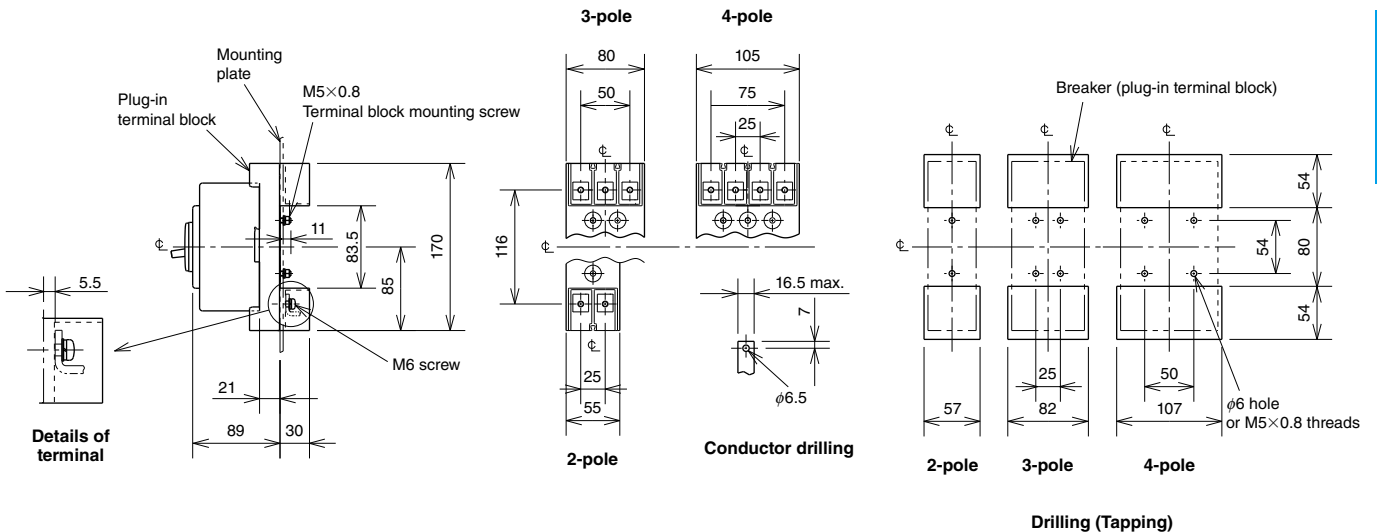

Remark: 1. Only 2-pole and 3-pole models are available for NF32-SV and NF63-CV.  
 2. We only have motor breakers for 3-pole models.

## NF125-CV NF125-SV NF125-HV



NF125-SV

Model	NF125-CV				NF125-SV			NF125-HV			NF125-SV[MB]						
Rated current I <sub>n</sub> (A)	50 (60) 63 (75) 80				(15) 16 20 (30) 32			(15) 16 20 (30) 32			(12.5) (16) (25)						
Reference ambient temperature 40°C	100 125				40 50 (60) 63 (75)			80 100 125			71 90 100						
Number of poles	2		3		2	3	4	2	3	4	3						
Rated insulation voltage U <sub>i</sub> (V)	600				690			690			500						
Rated short-circuit breaking capacity (kA)	IEC 60947-2 EN 60947-2 (Icu/Ics)	AC	690V	-				8/8			10/8			-			
				500V	7.5/4				18/18			30/23			-		
				440V	10/5				25/25			50/38			25/25		
				415V	10/5				30/30			50/38			30/30		
				400V	10/5				30/30			50/38			30/30		
				380V	10/5				30/30			50/38			30/30		
				230V	30/15				50/50			100/75			50/50		
200V	30/15				50/50			100/75			-						
DC	250V (*1)		7.5/4		40/40			-			-						
Standard attached parts (front connection)					Terminal screw: M8×14 (2P: 4pcs, 3P: 6pcs, 4P: 8pcs) Mounting screw: M4×0.7×55 (2 and 3P: 2pcs, 4P: 4pcs) (*2) Insulation barrier: (2P: 1pc, 3P: 2pcs, 4P: 3pcs)												

Notes \*1 Use two poles for 3- and 4-pole products.  
If wired as shown at the bottom on page 18, 3- and 4-poles can be used for up to 400 and 500VDC, respectively.  
\*2 Supplied with NF125-SV and NF125-HV.

## Operating Characteristics

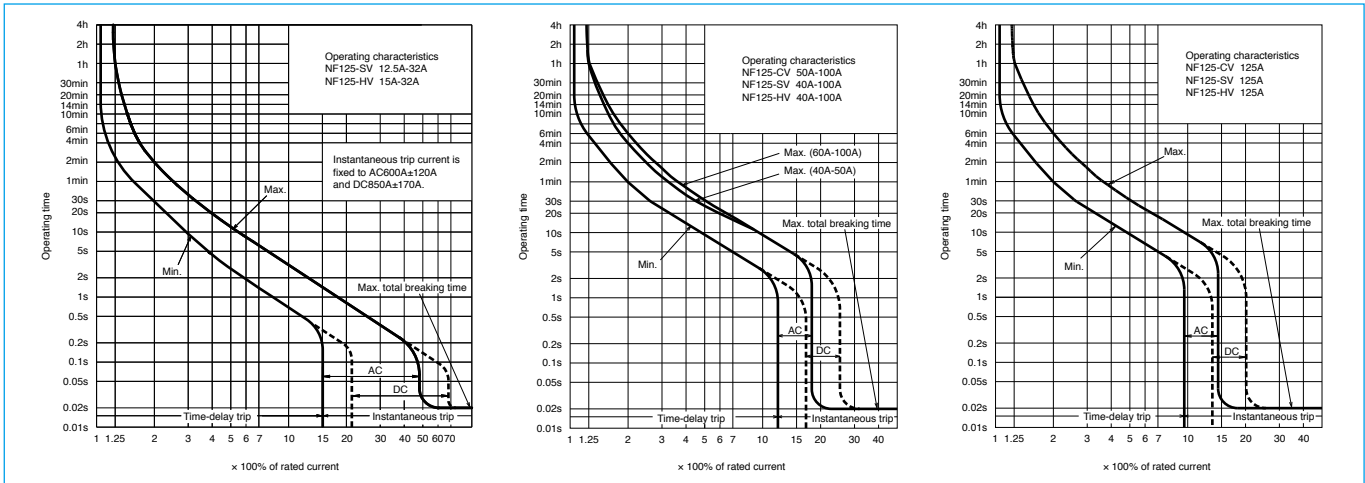

## Internal Accessories

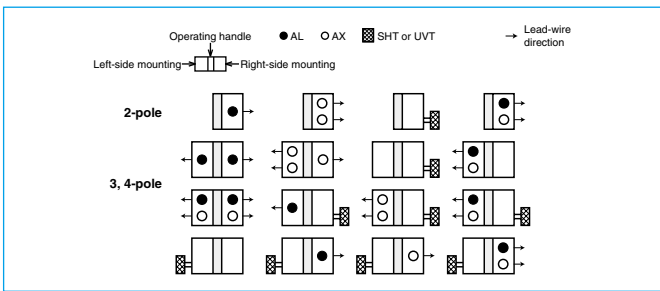

## Temperature Compensation Curve

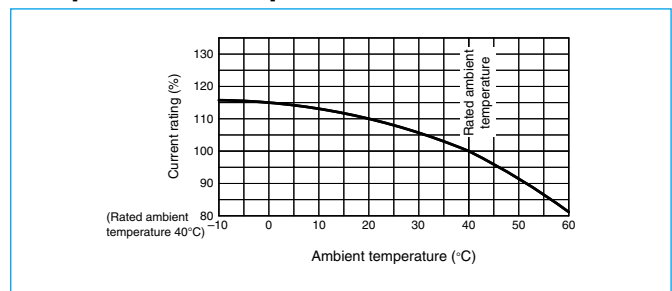

## External Accessories

Accessories	Type name	Reference page	Accessories	Type name	Reference page	
Operating handle	F 2P F-1SV2	123	Mechanical interlock	MI 2, 3P MI-05SV3	136	
	F 3, 4P F-1SV			MI 4P MI-05SV4		
Lock cover	V 2P V-1SV2	125	Terminal cover	2P TCS-1SV2	128	
	V 3, 4P V-1SV			3P TCS-1SV3		
Handle lock device	LC LC-05SV	134		Small		4P TCS-1SV4
	HL(*1) HLF-05SV					2P TCL-1SV2
	HLN-05SV					3P TCL-1SV3
HL-S HLS-05SV	4P TCL-1SV4					
				Large		2P TTC-1SV2
						3P TTC-1SV3
			4P TTC-1SV4			
			2P BTC-1SV2			
			Rear	3P BTC-1SV3		
				4P BTC-1SV4		
				2P PTC-1SV2		
				3P PTC-1SV3		
			Plug-in	4P PTC-1SV4		
Electrical operation device			(*2)		140	

Notes \*1 HLF types are used for OFF lock and HLN types for ON lock.  
\*2 Specify the working voltage. Refer to the reference page for type name.

Outline Drawing

Front connection

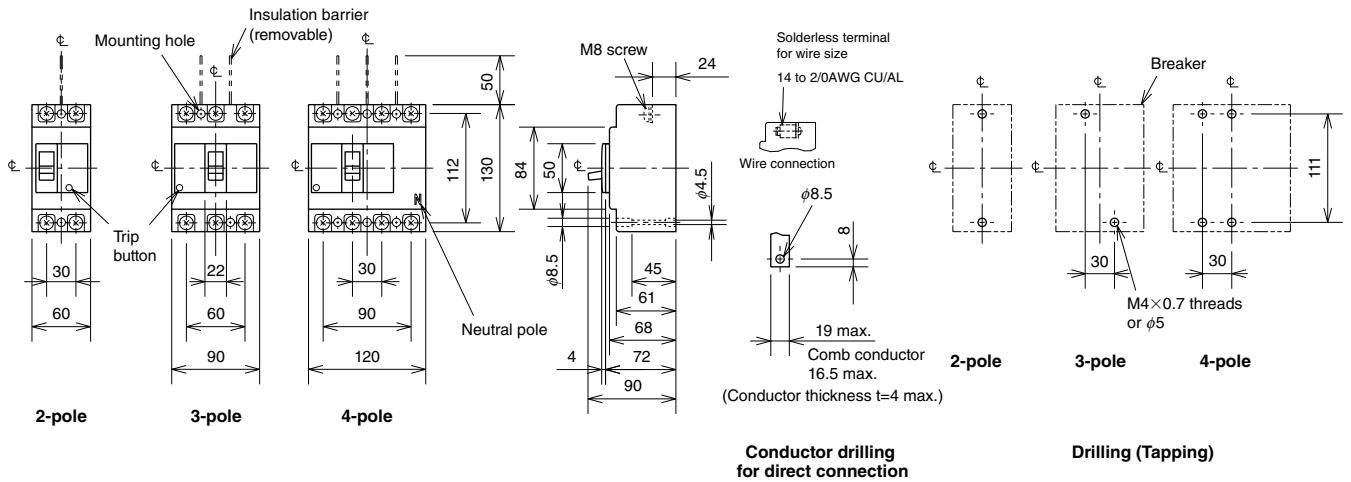

Rear connection

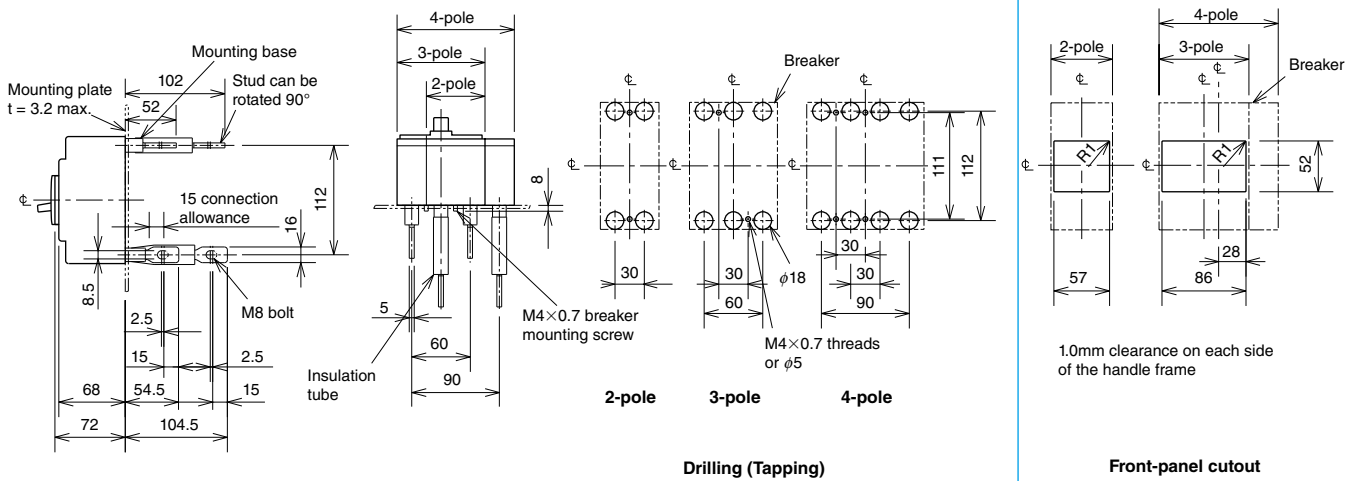

Plug-in

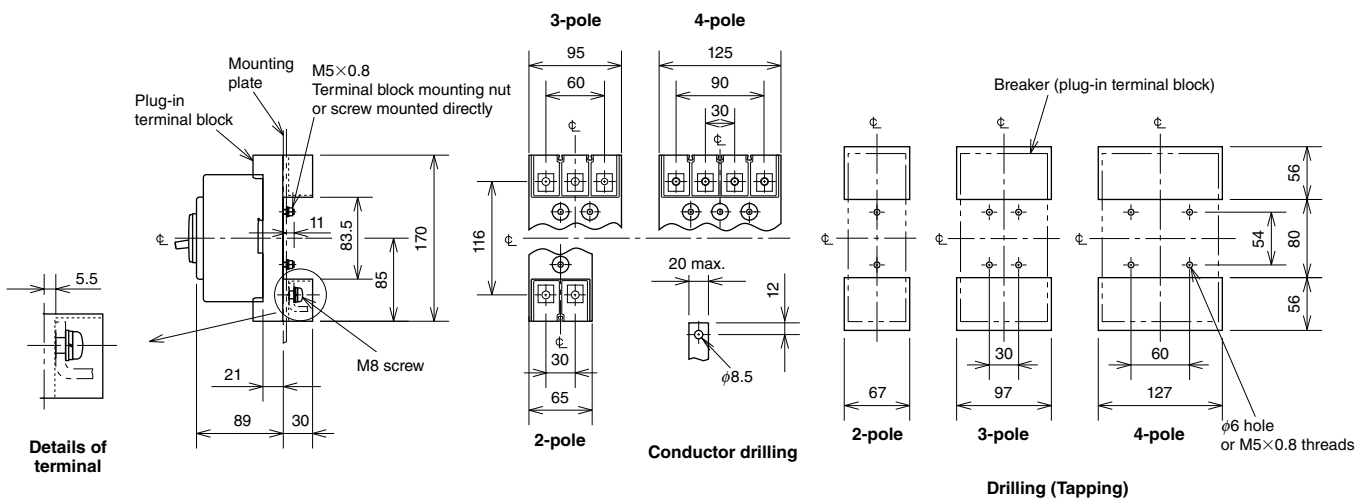

Remarks: 1. The 2-pole models of NF125-HV are 3-pole models with the central pole removed.  
 2. Only 2- and 3-pole models are available for NF125-CV.  
 3. We only have motor breakers for 3-pole models.

## NF125-UV



NF125-UV

Model		NF125-UV		
Rated current I <sub>n</sub> (A)		15 20 30 40 50		
Reference ambient temperature 40°C		60 75 100 125		
Number of poles		2	3	4
Rated insulation voltage U <sub>i</sub> (V)		690		
Rated short-circuit breaking capacity (kA)	IEC 60947-2 EN 60947-2 (Icu/Ics)	AC	690V	10/10
			500V	200/200
			440V	200/200
			415V	200/200
			400V	200/200
			380V	200/200
			230V	200/200
			200V	200/200
DC	250V	-		
Standard attached parts (front connection)		Terminal screw: M8×14 (2P: 4pcs, 3P: 6pcs, 4P: 8pcs) Mounting screw: M4×0.7×55 (2 and 3P: 2pcs, 4P: 4pcs) M4×0.7×73 (2 and 3P: 2pcs)		

## Operating Characteristics

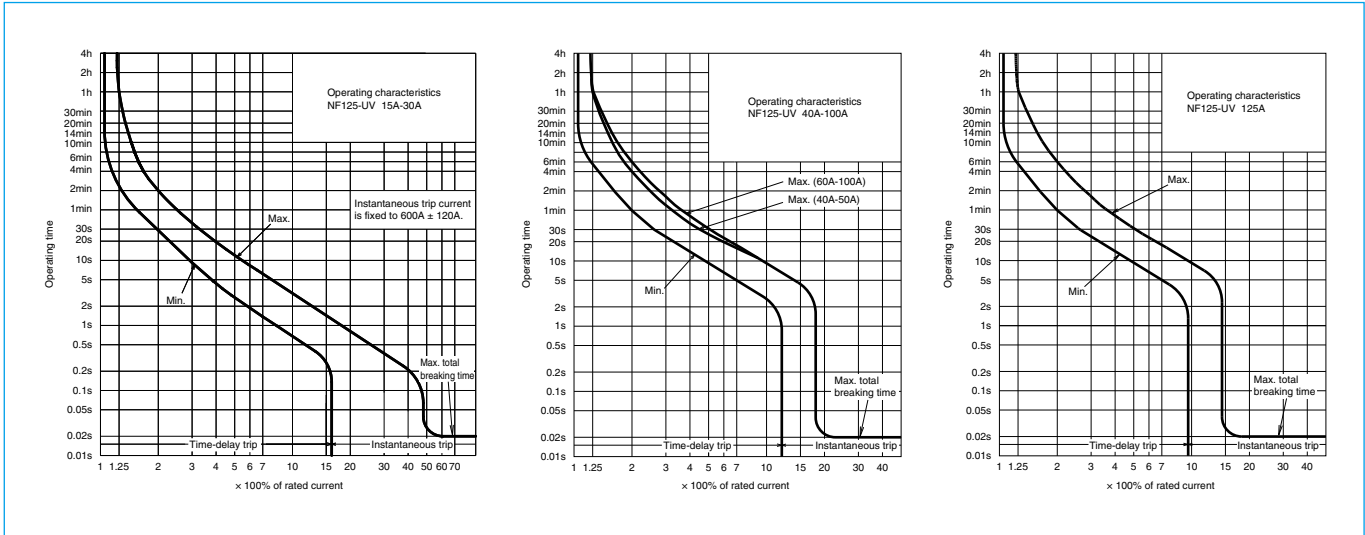

## Internal Accessories

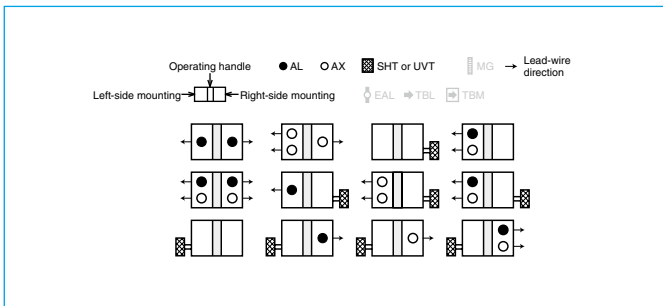

## Temperature Compensation Curve

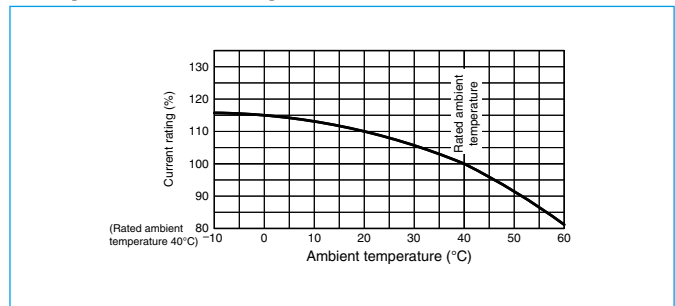

## External Accessories

Accessories		Type name	Reference page	Accessories		Type name	Reference page	
Operating handle	F	F-1UV	123	Mechanical interlock	2, 3P	MI-05SV3	136	
	V	V-1UV	125		4P	MI-05SV4		
Lock cover	LC	LC-05SV	134	Terminal cover	Small	3P	TCS-1SV3	128
Handle lock device	HL (*1)	HLF-05SV				4P	TCS-1SV4	
		HLN-05SV			4P	TCL-1SV3		
		HLS-05SV				TCL-1SV4		
Electrical operation device	(*2)			Skeleton	3P	TTC-1SV3	128	
					4P	TTC-1SV4		
				Rear	3P	BTC-1SV3	140	
					4P	BTC-1SV4		
Plug-in	PTC			3P	PTC-1SV3	140		
				4P	PTC-1SV4			

Notes \*1 HLF types are used for OFF lock and HLN types for ON lock.  
\*2 Specify the working voltage. Refer to the reference page for type name.

Outline Drawing

Front connection

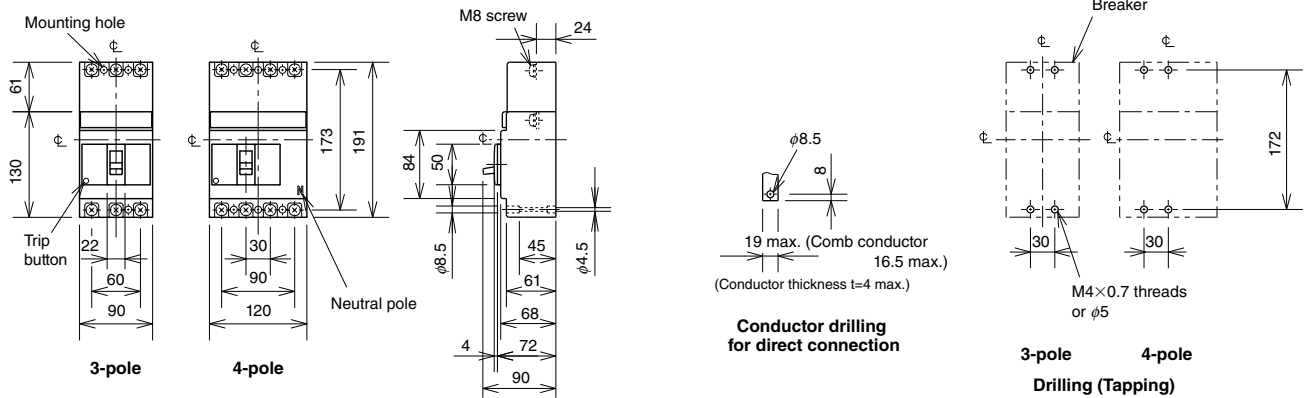

Rear connection

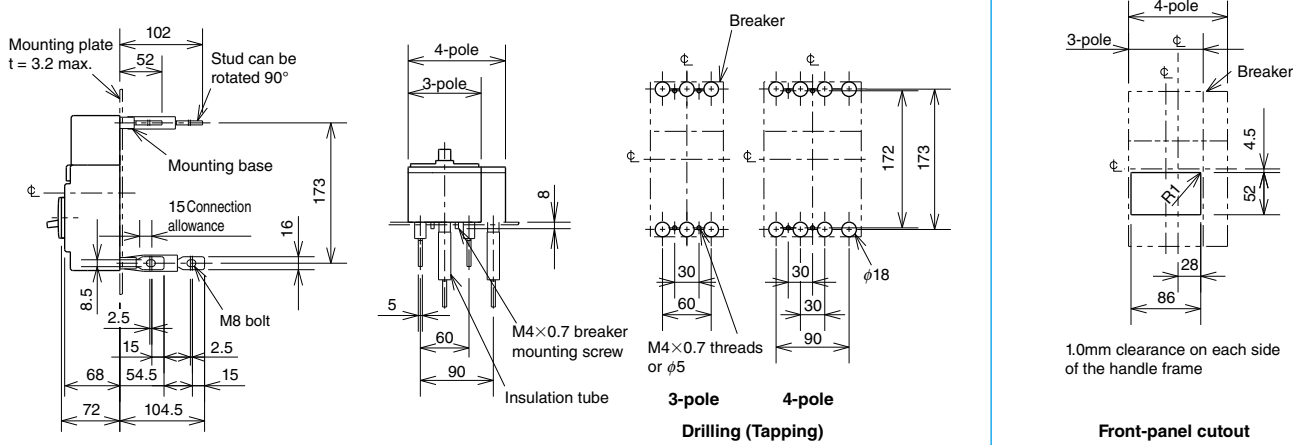

Plug-in

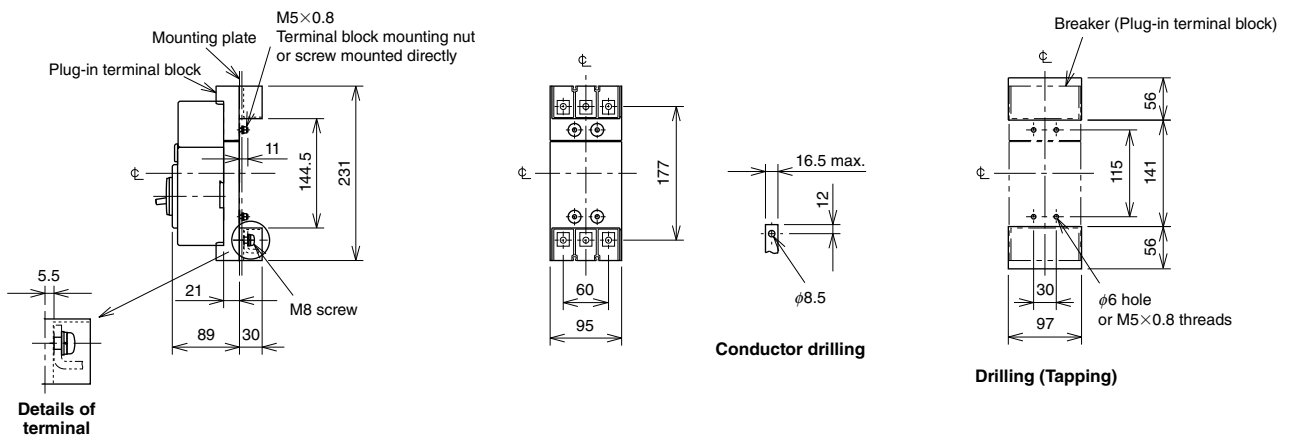

Remark: 1. 2-pole models are 3-pole models with the central pole removed.

## NF250-CV NF250-SV NF250-HV



NF250-SV

Model		NF250-CV				NF250-SV			NF250-HV			NF250-SV[MB]	
Rated current In (A)		(100)				(100)			125 150 160 175			125 150	
Reference ambient temperature 40°C		125 150 175 200 225 250				125 150 160 175 200 225 250			200 225 250			175 200 225	
Number of poles		2		3		2	3	4	2	3	4	3	
Rated insulation voltage Ui (V)		600				690			690			500	
Rated short-circuit breaking capacity (kA)	IEC 60947-2 EN 60947-2 (Icu/Ics)	AC	690V	-		8/8		10/8		-		-	
				500V		10/8		30/30		50/38		-	
				440V		15/12		36/36		65/65		36/36	
				415V		25/19		36/36		70/70		36/36	
				400V		25/19		36/36		75/75		36/36	
				380V		25/19		36/36		75/75		36/36	
				230V		36/27		85/85		100/100		85/85	
				200V		36/27		85/85		100/100		-	
		DC (*1)	250V		15/12		20/20 (300V)		40/40 (300V)		-		
Standard attached parts (front connection)		Terminal screw: M8 (Bolt(Hex-socket))x16 (2P: 4pcs, 3P: 6pcs, 4P: 8pcs) Mounting screw: M4x0.7x55 (2 and 3P: 2pcs, 4P: 4pcs) Insulation barrier: (2P: 2pcs, 3P: 4pcs, 4P: 6pcs)											

Note \*1 Use two poles for 3- and 4-pole products. In this case, do not use the neutral pole of the 4-pole products. If wired as shown at the bottom of page 18, 3-pole NF250-CV can be used for up to 400VDC, 3-pole NF250-SV and NF250-HV up to 500VDC and 4-pole products up to 600VDC.

## Operating Characteristics

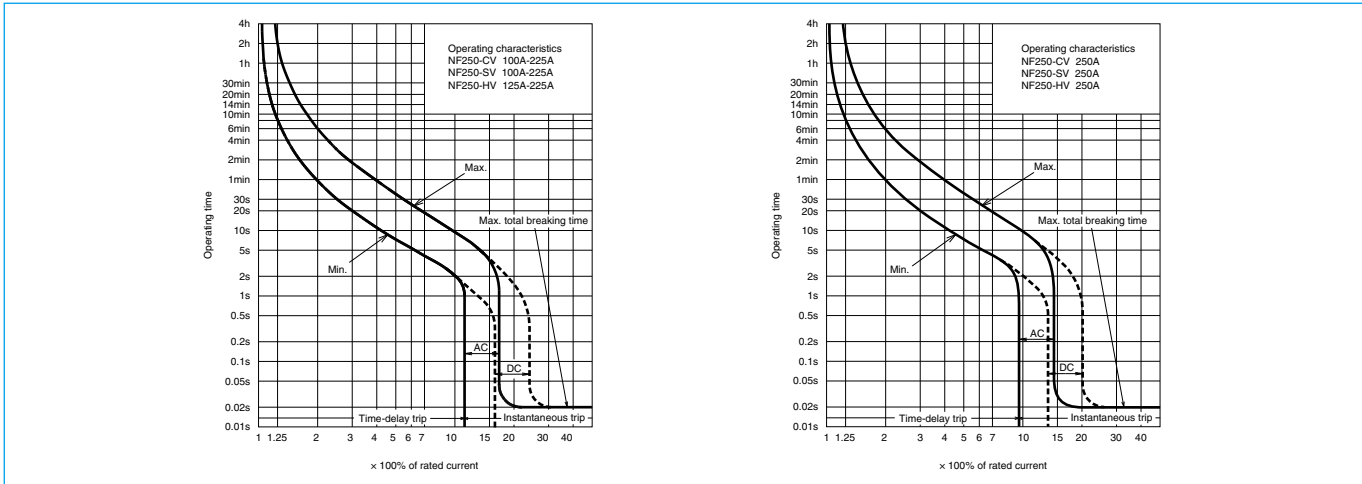

## Internal Accessories

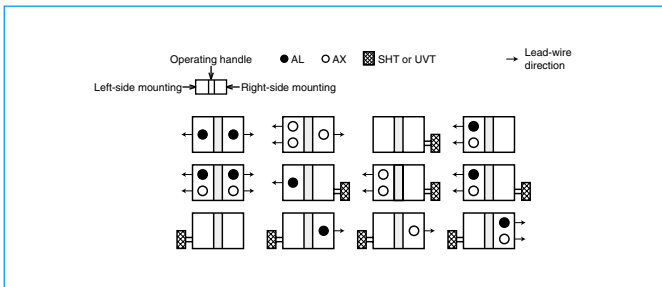

## Temperature Compensation Curve

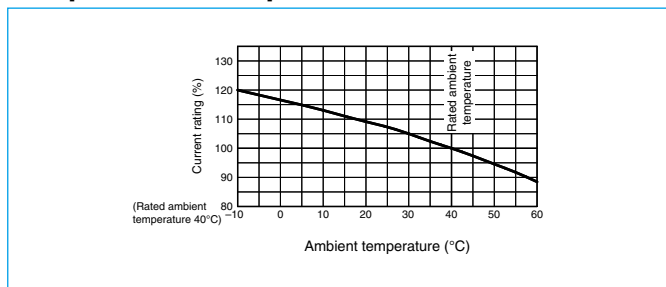

## External Accessories

Accessories		Type name	Reference page	Accessories		Type name	Reference page
Operating handle	F	F-2SV	123	Mechanical interlock	MI	2, 3P MI-05SV3	136
	V	V-2SV	125				
Lock cover	LC	LC-05SV	134	Terminal cover	Small	2, 3P TCS-2SV3	128
Handle lock device	HL(*1)	HLF-05SV				4P TCS-2SV4	
		HLN-05SV			2, 3P TCL-2SV3		
		HLS			4P TCL-2SV4		
			2, 3P TCL-2SV3L				
			4P TCL-2SV4				
			2, 3P TTC-2SV3				
			4P TTC-2SV4				
			2, 3P BTC-2SV3				
			4P BTC-2SV4				
			2, 3P PTC-2SV3				
			4P PTC-2SV4				
Electrical operation device						(*2)	140

Notes \*1 HLF types are used for OFF lock and HLN types for ON lock.  
\*2 Specify the working voltage. Refer to the reference page for type name.

Outline Drawing

Front connection

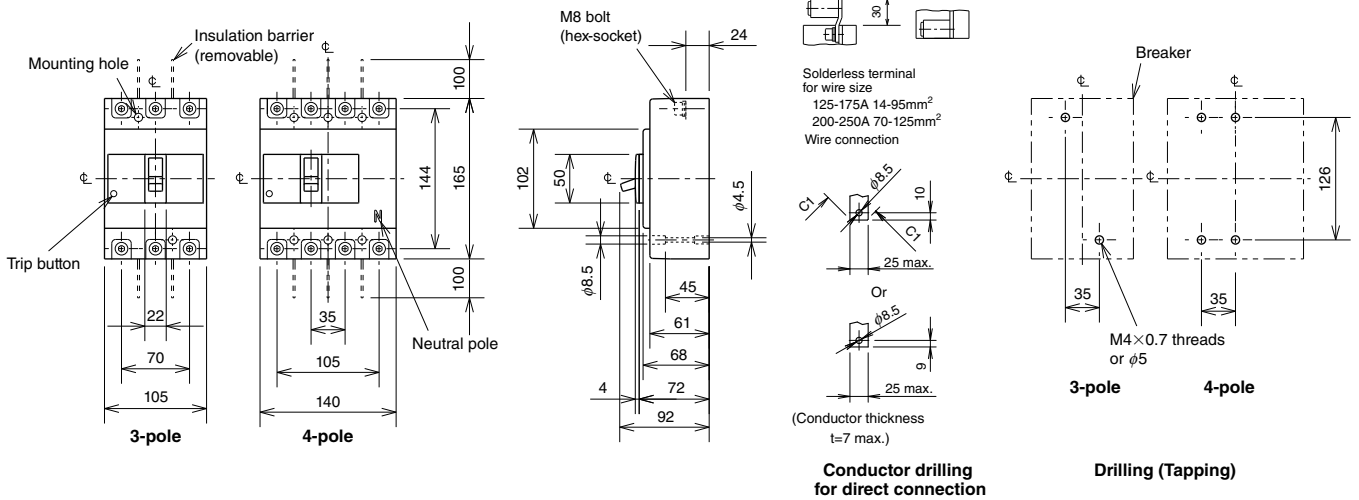

Rear connection

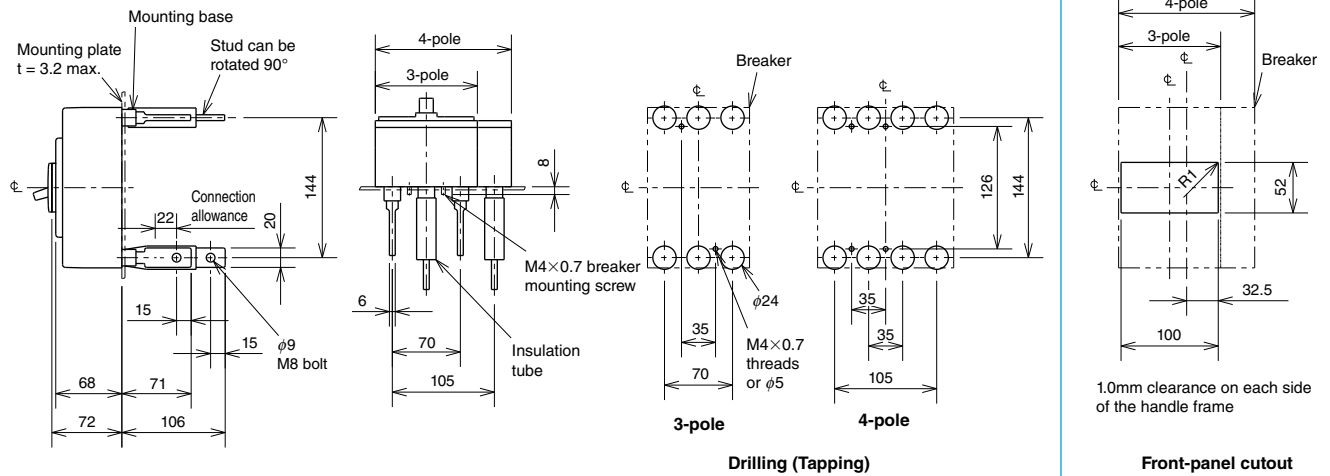

Plug-in

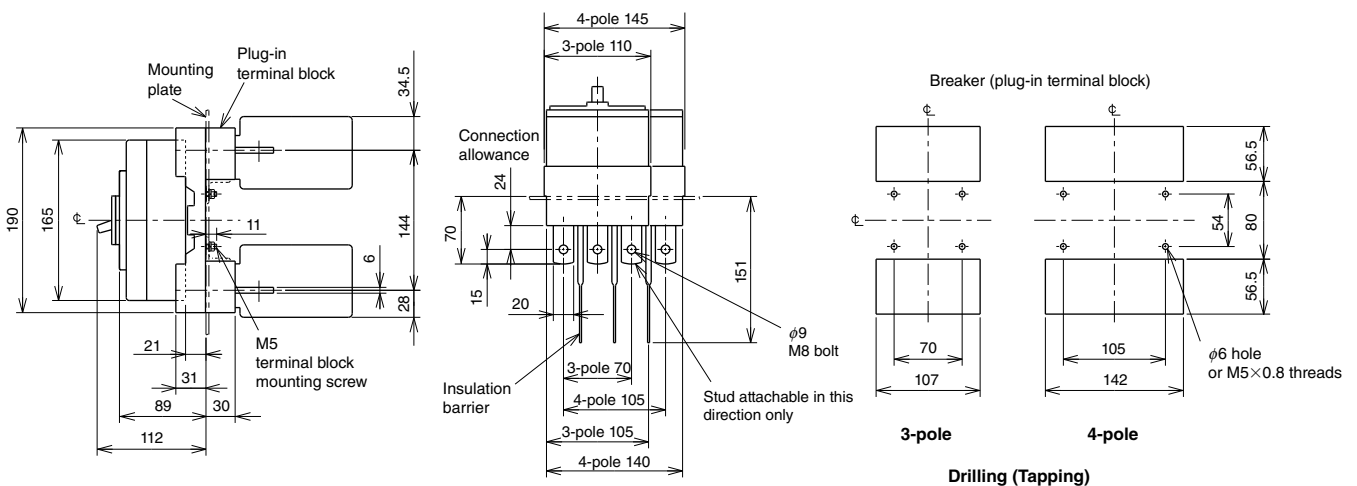

Remarks: 1. 2-pole models are 3-pole models with the central pole removed.  
 2. Only 2-pole and 3-pole models are available for NF250-CV.  
 3. We only have motor breakers for 3-pole models.

### NF250-UV



NF250-UV

Model		NF250-UV		
Rated current In (A)		125 150 175		
Reference ambient temperature 40°C		200 225 250		
Number of poles		2	3	4
Rated insulation voltage Ui (V)		690		
Rated short-circuit breaking capacity (kA)	IEC 60947-2 EN 60947-2 (Icu/Ics)	AC	690V	15/15
			500V	200/200
			440V	200/200
			415V	200/200
			400V	200/200
			380V	200/200
			230V	200/200
			200V	200/200
DC	250V	-		
Standard attached parts (front connection)		Terminal screw: M8 (Bolt(Hex-socket))x16 (2P: 4pcs, 3P: 6pcs, 4P: 8pcs) Mounting screw: M4x0.7x55 (2 and 3P: 2pcs, 4P: 4pcs) Mounting screw: M4x0.7x73 (2 and 3P: 2pcs) Insulation barrier: (2P: 2pcs, 3P: 4pcs, 4P: 6pcs)		

### Operating Characteristics

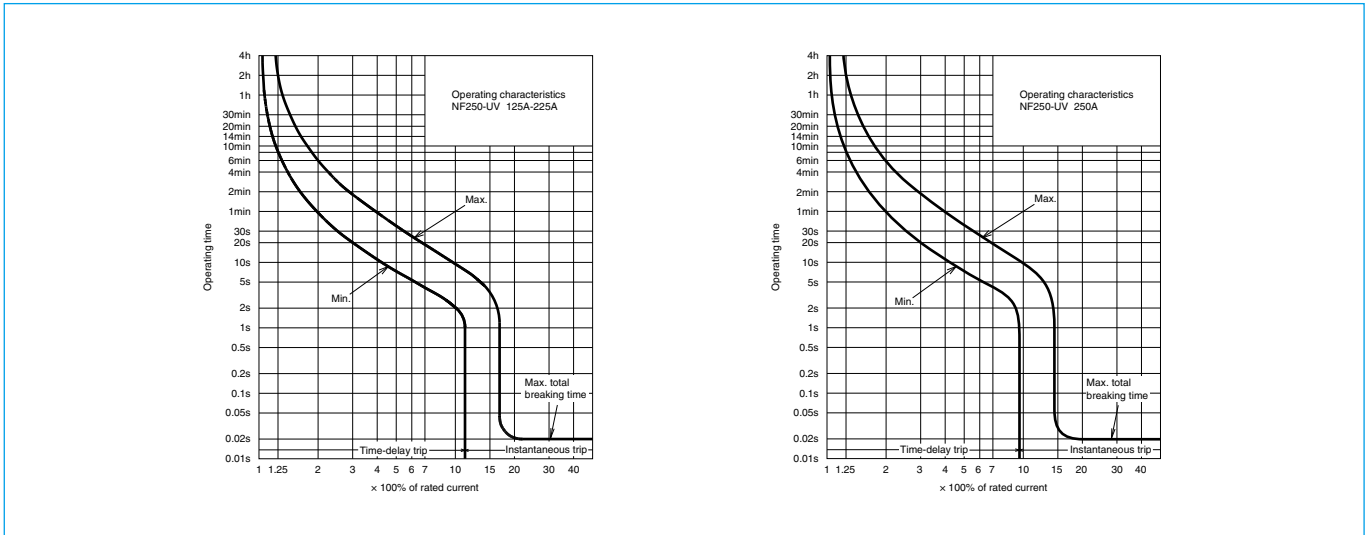

### Internal Accessories

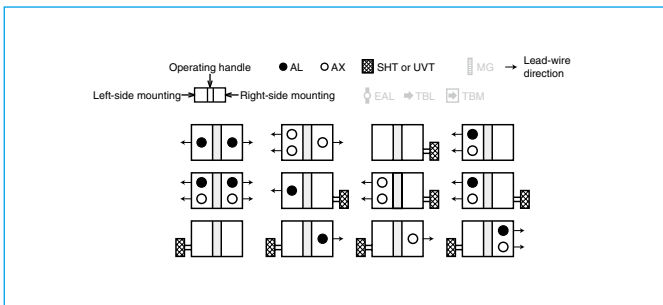

### Temperature Compensation Curve

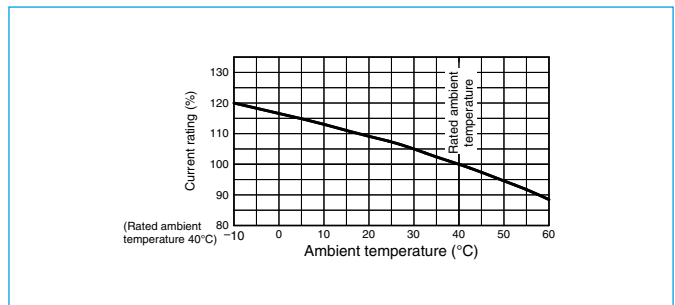

### External Accessories

Accessories		Type name	Reference page	Accessories		Type name	Reference page	
Operating handle	F	F-2UV	123	Mechanical interlock	MI	2, 3P MI-05SV3	136	
	V	V-2UV	125					4P MI-2SV4
Lock cover	LC	LC-05SV	134	Terminal cover	Small	TC-S	2, 3P TCS-2SV3	128
Handle lock device	HL(*1)	HLF-05SV						
		HLN-05SV				Large	TC-L	
	HLS	HLS-2SV					4P TCL-2SV4	
					Skeleton	TTC	2, 3P TTC-2SV3	
							4P TTC-2SV4	
					Rear	BTC	2, 3P BTC-2SV3	
							4P BTC-2SV4	
				Plug-in	PTC	2, 3P PTC-2SV3		
						4P PTC-2SV4		
				Electrical operation device		(*2)	140	

Notes \*1 HLF types are used for OFF lock and HLN types for ON lock.  
\*2 Specify the working voltage. Refer to the reference page for type name.

Outline Drawing

Front connection

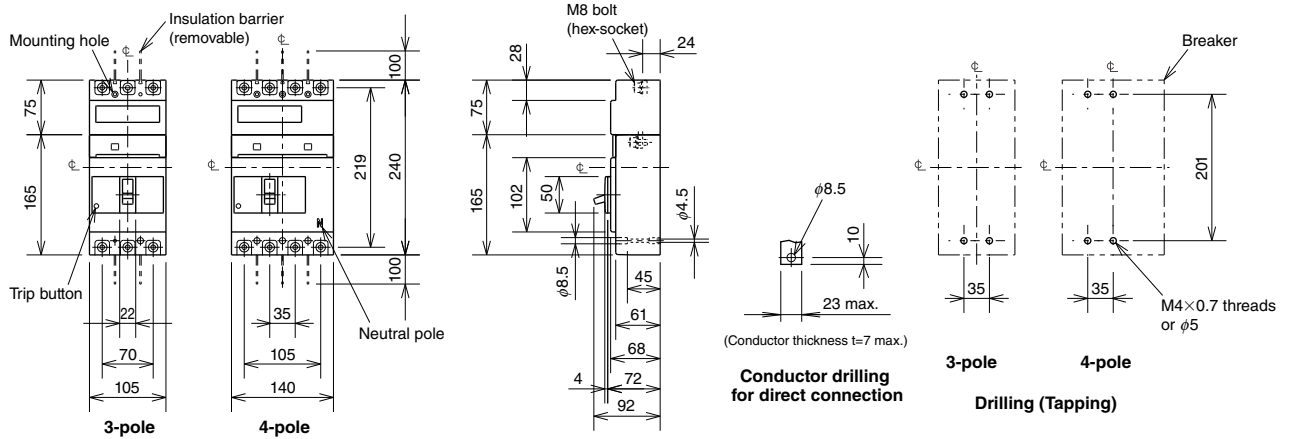

Rear connection

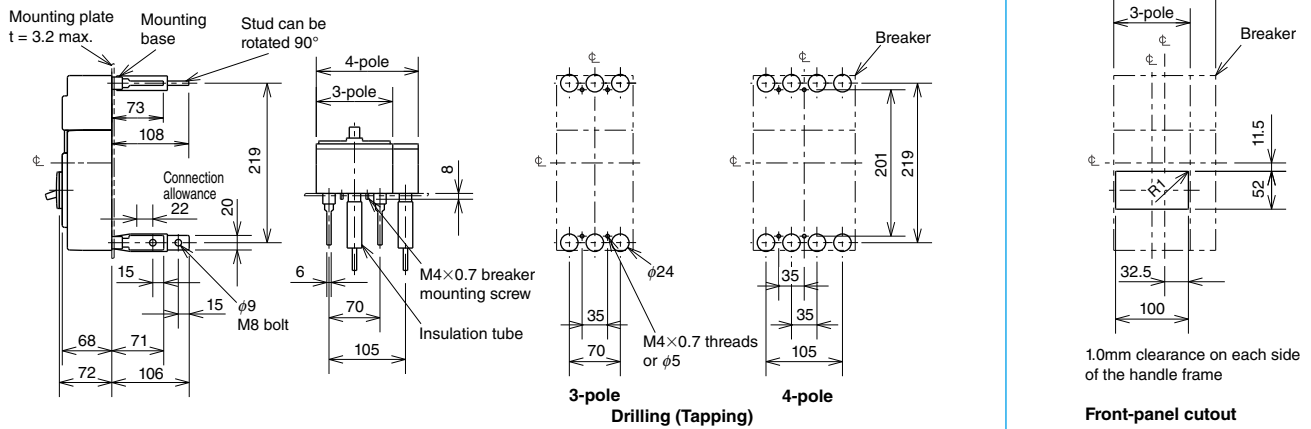

Plug-in

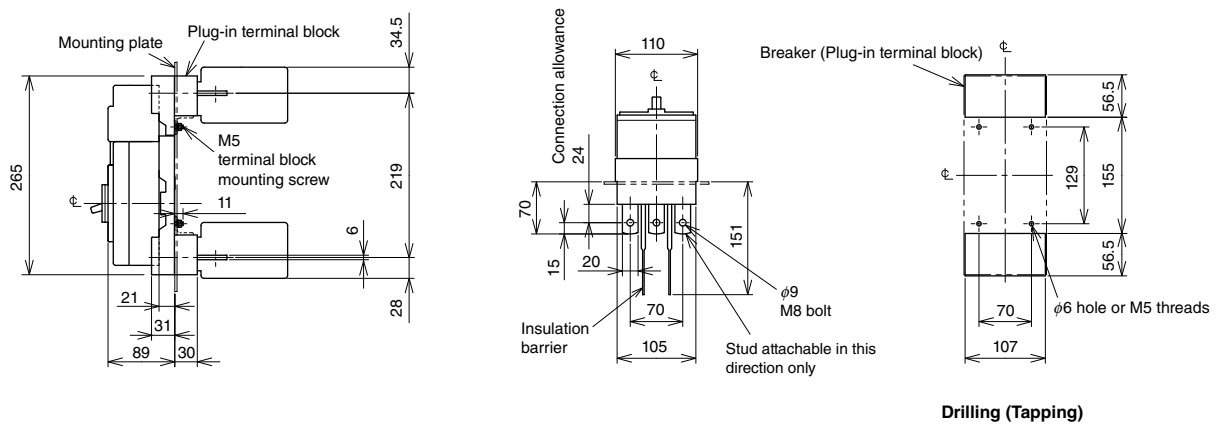

Remark: 1. 2-pole models are 3-pole models with the central pole removed.

# 7 Characteristics and Dimensions 1

# Molded Case Circuit Breakers

- NF125-SGV
- NF250-SGV
- NF160-LGV
- NF125-HGV
- NF250-HGV
- NF250-RGV
- NF160-SGV
- NF125-LGV
- NF250-LGV
- NF160-HGV
- NF125-RGV



NF250-SGV

Model	NF125-SGV	NF160-SGV	NF250-SGV	NF125-LGV	NF160-LGV	NF250-LGV	
Rated current I <sub>n</sub> (A)	16-20 20-25 25-32 32-40 35-50 45-63 56-80 70-100 90-125	125-160	125-160 140-200 175-250	16-20 20-25 25-32 32-40 35-50 45-63 56-80 70-100 90-125	125-160	125-160 140-200 175-250	
Reference ambient temperature 40°C							
Number of poles	2 3 4	2 3 4	2 3 4	2 3 4	2 3 4	2 3 4	
Rated insulation voltage U <sub>i</sub> (V)	690	690	690	690	690	690	
Rated short-circuit breaking capacity (kA)	IEC 60947-2 EN 60947-2 (I <sub>cu</sub> /I <sub>cs</sub> )	AC	690V	8/8	8/8	8/8	8/8
			500V	30/30	30/30	36/36	36/36
			440V	36/36	36/36	36/36	50/50
			415V	36/36	36/36	36/36	50/50
			400V	36/36	36/36	36/36	50/50
			380V	36/36	36/36	36/36	50/50
			230V	85/85	85/85	85/85	90/90
			200V	85/85	85/85	85/85	90/90
			300V	20/20	20/20	20/20	20/20
			DC (*)	300V	20/20	20/20	20/20
Standard attached parts (front connection)	Mounting screw: M4×0.7×55 (2 and 3P: 2pcs, 4P: 4pcs) Insulation barrier: (2P: 2pcs, 3P: 4pcs, 4P: 6pcs)						

Model	NF125-HGV	NF160-HGV	NF250-HGV	NF125-RGV	NF250-RGV	
Rated current I <sub>n</sub> (A)	16-20 20-25 25-32 32-40 35-50 45-63 56-80 70-100 90-125	125-160	125-160 140-200 175-250	16-20 20-25 25-32 32-40 40-50 50-63 63-80 80-100 100-125	125-160 160-200 200-250	
Reference ambient temperature 40°C						
Number of poles	2 3 4	2 3 4	2 3 4	2 3	2 3	
Rated insulation voltage U <sub>i</sub> (V)	690	690	690	690	690	
Rated short-circuit breaking capacity (kA)	IEC 60947-2 EN 60947-2 (I <sub>cu</sub> /I <sub>cs</sub> )	AC	690V	10/8	10/8	—
			500V	50/38	50/38	—
			440V	65/65	65/65	125/125
			415V	70/70	70/70	150/150
			400V	75/75	75/75	150/150
			380V	75/75	75/75	150/150
			230V	100/100	100/100	150/150
			200V	100/100	100/100	150/150
			300V	40/40	40/40	—
			DC (*)	300V	40/40	40/40
Standard attached parts (front connection)	Mounting screw: M4×0.7×55 (2 and 3P: 2pcs, 4P: 4pcs) Insulation barrier: (2P: 2pcs, 3P: 4pcs, 4P: 6pcs)					

Note \*1 When wired as shown at the bottom of page 18, 3-pole models can be used for up to 500VDC, and 4-pole models for up to 600VDC.

## Operating Characteristics

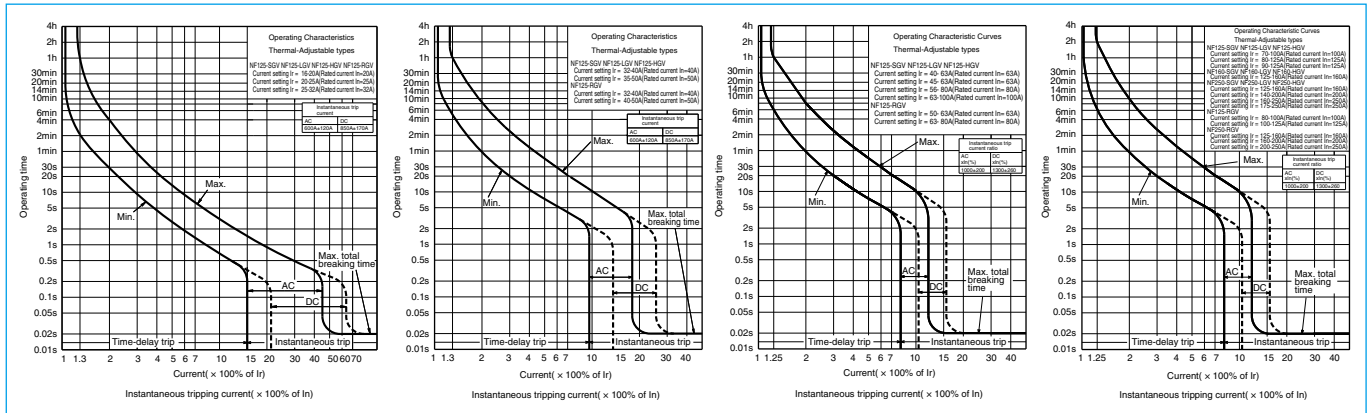

## Internal Accessories

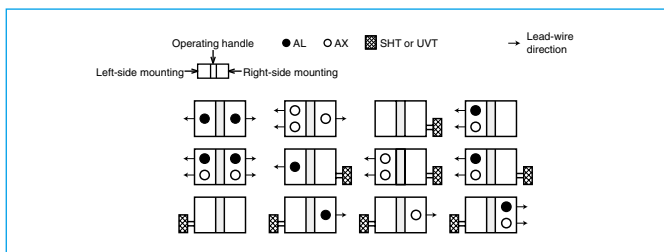

## Temperature Compensation Curve

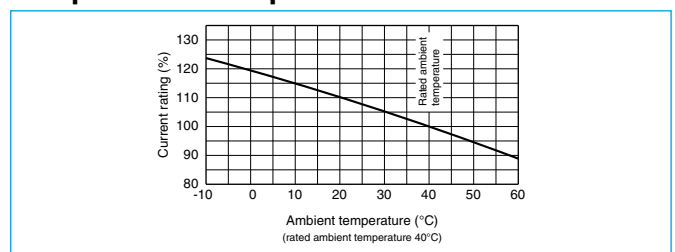

## External Accessories

Accessories	Type name	Reference page	Accessories	Type name	Reference page	
Operating handle	F	F-2SV	Mechanical interlock	MI	2, 3P MI-05SV3	
	V	V-2SV		4P MI-2SV4	136	
Lock cover	LC	LC-05SV	Terminal cover	Small	2, 3P TCS-2SV3	
	HL(*1)	HLF-05SV			4P TCS-2SV4	
Handle lock device	HL-S	HLS-2SV		Large	2, 3P TCL-2SV3	
	HL(*1)	HLN-05SV			4P TCL-2SV3L	
	HL-S	HLS-2SV		4P TCL-2SV4		
Notes	*1 HLF types are used for OFF lock and HLN types for ON lock.			Skeleton	2, 3P TTC-2SV3	128
	*2 Specify the working voltage. Refer to the reference page for type name.				4P TTC-2SV4	
	Rear	2, 3P BTC-2SV3		Plug-in	2, 3P PTC-2SV3	
		4P BTC-2SV4			4P PTC-2SV4	
Electrical operation device				(*2)		140

Outline Drawing

Front connection

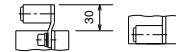
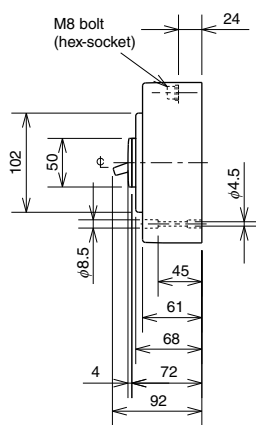
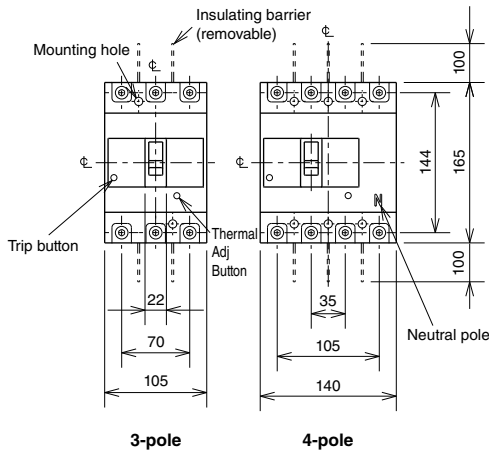

Solderless terminal for wire size  
125-175A 14-95mm<sup>2</sup>  
200-250A 70-125mm<sup>2</sup>  
Wire connection

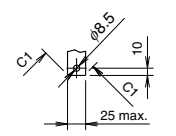

(Conductor thickness t=7 max.)

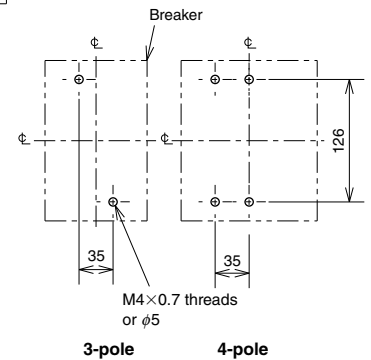

Conductor drilling for direct connection

Drilling (Tapping)

Rear connection

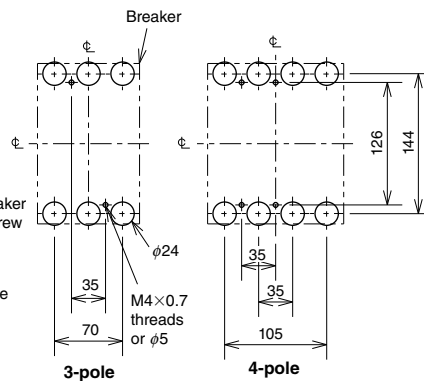
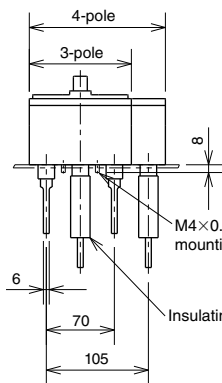
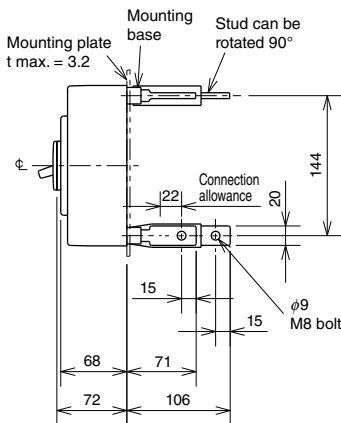

Drilling (Tapping)

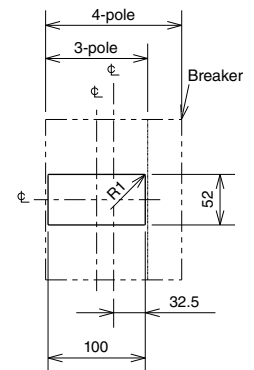

1mm clearance on each side of the handle frame

Front-panel cutout

Plug-in

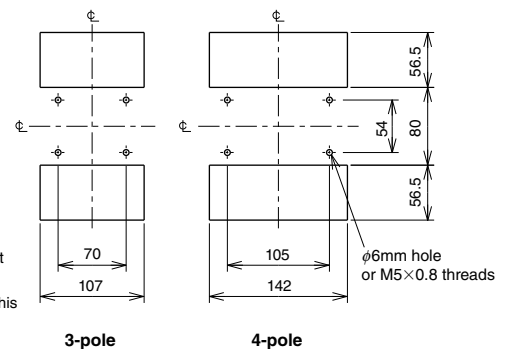
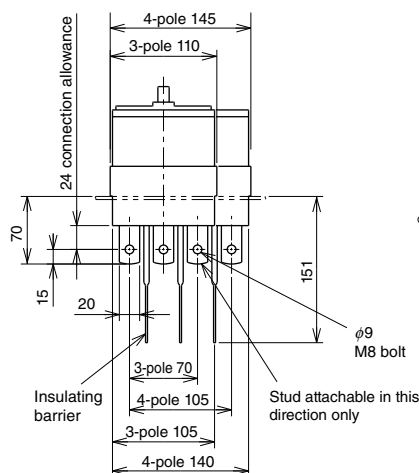
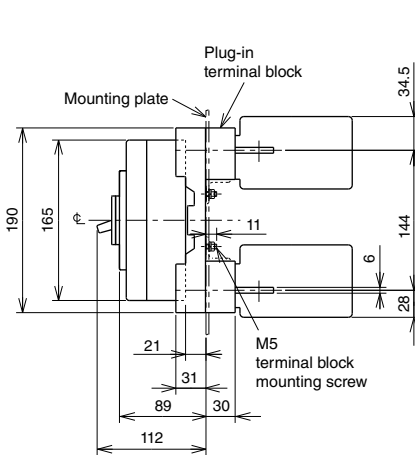

Drilling (Tapping)

Remark: 1. 2-pole models are 3-pole models with the central pole removed.

# 7 Characteristics and Dimensions 1

## Molded Case Circuit Breakers

NF125-SEV  
NF125-HEV  
NF250-SEV  
NF250-HEV



NF250-SEV

Model		NF125-SEV	NF125-HEV	NF250-SEV	NF250-HEV		
Rated current I <sub>n</sub> (A) Reference ambient temperature 40°C		32 63 125	32 63 125	160 250	160 250		
Current setting I <sub>r</sub> (A)		Adjustable 16-32 32-63 63-125 (1.6A step) (3.15A step) (6.25A step)		Adjustable 80-160 125-250 (8A step) (12.5A step)			
Number of poles		3 4	3 4	3 4	3 4		
Rated insulation voltage U <sub>i</sub> (V)		690		690	690		
Rated short-circuit breaking capacity (kA)	IEC 60947-2 EN 60947-2 (Icu/Ics)	AC	690V	8/8	10/8	8/8	10/8
			500V	30/30	50/38	30/30	50/38
			440V	36/36	65/65	36/36	65/65
			415V	36/36	70/70	36/36	70/70
			400V	36/36	75/75	36/36	75/75
			380V	36/36	75/75	36/36	75/75
			230V	85/85	100/100	85/85	100/100
			200V	85/85	100/100	85/85	100/100
DC		250V		-		-	
Standard attached parts (front connection)		Terminal screw: M8(Bolt(Hex-socket))x16 (3P: 6pcs, 4P: 8pcs) Mounting screw: M4x0.7x55 (3P: 2pcs, 4P: 4pcs) Insulation barrier: (3P: 4pcs, 4P: 6pcs)					

### Operating Characteristics

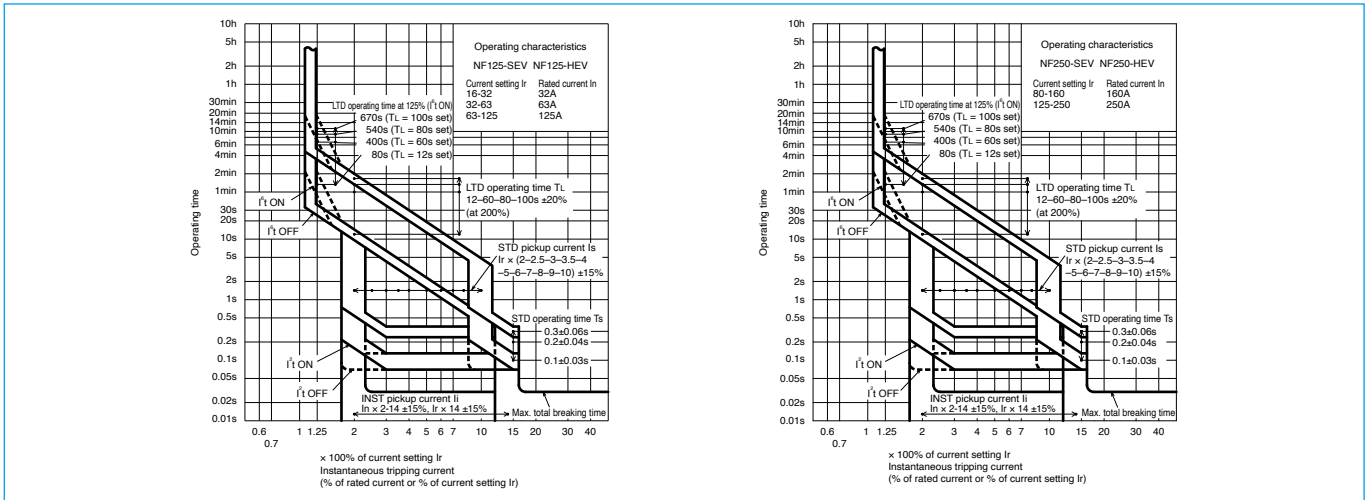

### Internal Accessories

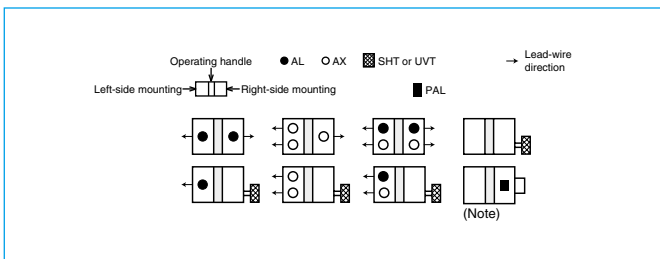

### Current Reducing Curve

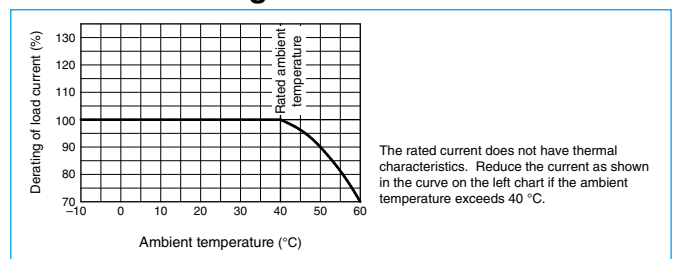

### External Accessories

Accessories		Type name	Reference page	Accessories		Type name	Reference page	
Operating handle	F	F-2SV	123	Mechanical interlock	MI	3P MI-05SV3	136	
	V	V-2SV	125					4P MI-2SV4
Lock cover	LC	LC-05SV	134	Terminal cover (*3)	Small	3P TCS-2SV3	128	
Handle lock device	HL(*1)	HLF-05SV						4P TCS-2SV4
		HLN-05SV				3P TCL-2SV3		
		HLS-2SV				4P TCL-2SV3L		
					Large	3P TCL-2SV4		
					Skeleton	TTC		3P TTC-2SV3
								4P TTC-2SV4
					Rear	BTC		3P BTC-2SV3
						4P BTC-2SV4		
				Plug-in	PTC	3P PTC-2SV3		
						4P PTC-2SV4		
				Electrical operation device		(*2)	140	

Notes \*1 HLF types are used for OFF lock and HLN types for ON lock.  
\*2 Specify the working voltage. Refer to the reference page for type name.  
\*3 For NF125-HEV and NF250-HEV with PAL, specify the model name with MP at the end.



## NF400-CW NF400-SW



Model		NF400-CW		NF400-SW	
Rated current In (A)		250 300		350 400	
Reference ambient temperature 40°C					
Number of poles		2	3	2	3 4
Rated insulation voltage Ui (V)		690		690	
Rated short-circuit breaking capacity (kA)	IEC 60947-2 EN 60947-2 (Icu/Ics)	AC	690V	–	10/10
			500V	15/8	30/30
			440V	25/13	42/42
			415V	36/18	45/45
			400V	36/18	45/45
			380V	40/20	50/50
			230V	50/25	85/85
			200V	50/25	85/85
	DC (*1)	250V	20/10	40/40	
Standard attached parts		Front connection	Terminal screw: M12 boltx35 (2-pole: 4pcs, 3-pole: 6pcs, 4-pole: 8pcs) Mounting screw: M6x60 (4pcs) Insulating barrier: (2P: 2pcs, 3P: 4pcs, 4P: 6pcs)		
		Rear connection	Terminal screw: M12 boltx35 (2-pole: 4pcs, 3-pole: 6pcs, 4-pole: 8pcs) Mounting screw: M6x72 (4pcs)		

Note \*1 When wired as shown at the bottom of page 18, 3-pole models can be used for up to 400VDC, and 4-pole models for up to 500VDC.

## Operating Characteristics

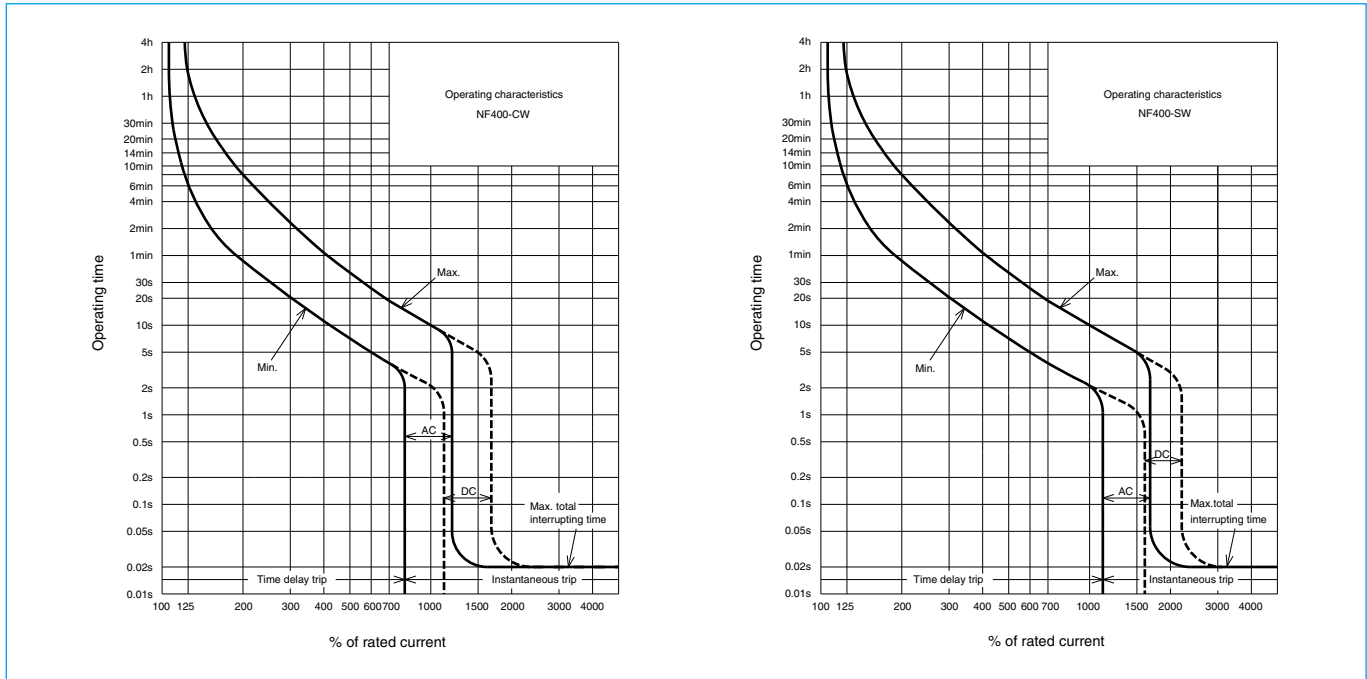

## Internal Accessories

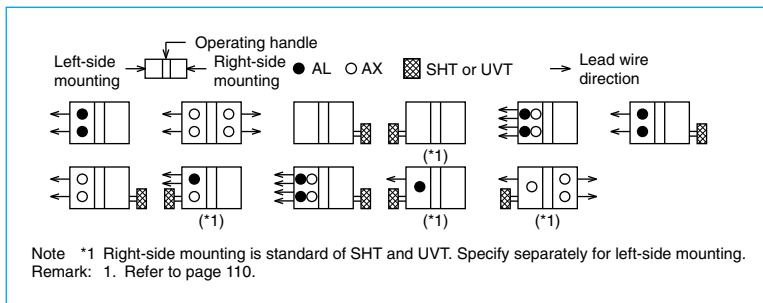

## Temperature Compensation Curve

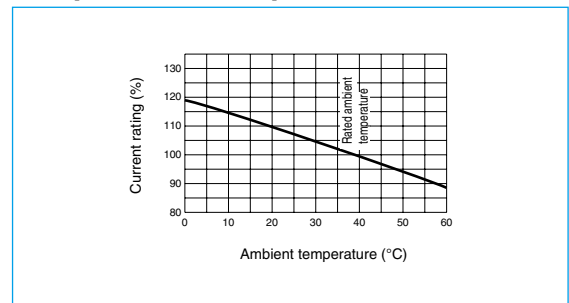

## External Accessories

Accessories		Type name	Reference page	Accessories		Type name	Reference page	
Operating handle	F	F-4S	123	Terminal cover	Large	TC-L 2, 3P	TCL-4SW3	
	V	V-4S	125			TC-L 4P	TCL-4SW4	
Mechanical interlock	MI	2, 3P	136		Skeleton	2, 3P	TTC-4SW3	128
		4P				MI-4SW4	TTC-4SW4	
Auxiliary handle	HT	135			Rear	2, 3P	BTC-4SW3	134
						4P	BTC-4SW4	
Handle lock device				HL		HL-4CW, HL-4SW		
				HL-S		HLS-4SW		
Electrical operation device				NFM	3P	(*1)		140
					4P			

Note \*1 Specify the operation method and voltage. Order in combination with the breaker unit.

Outline Drawing

**Front connection**

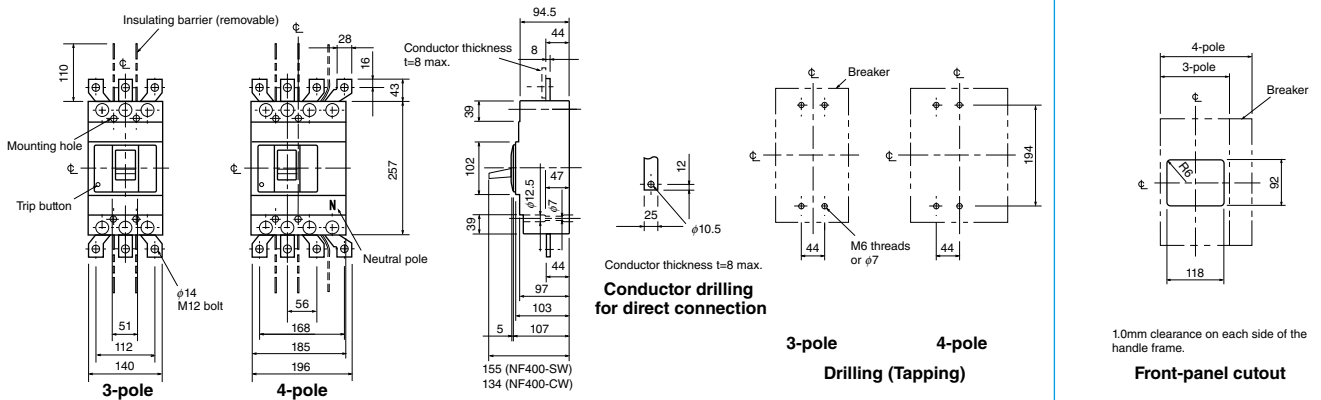

**Rear connection**

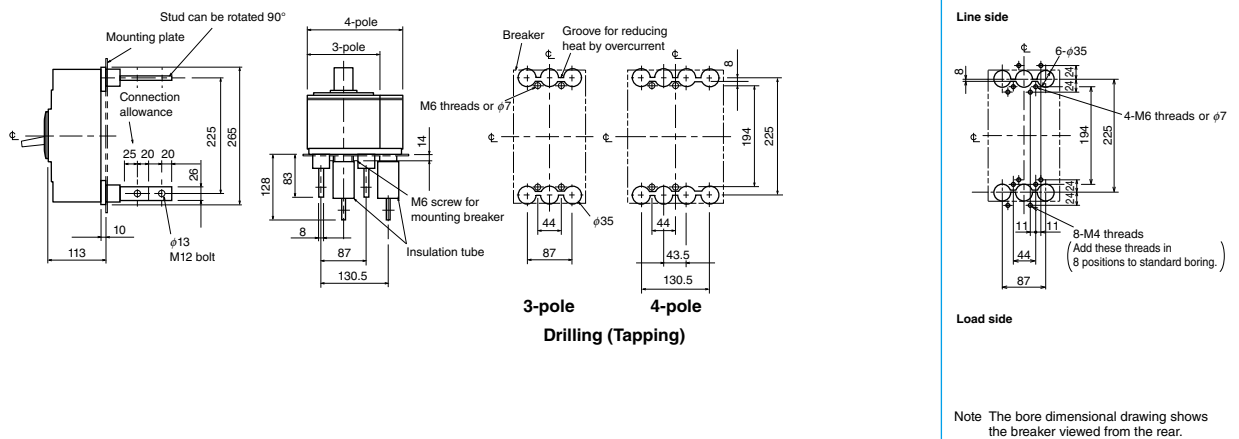

**Plug-in**

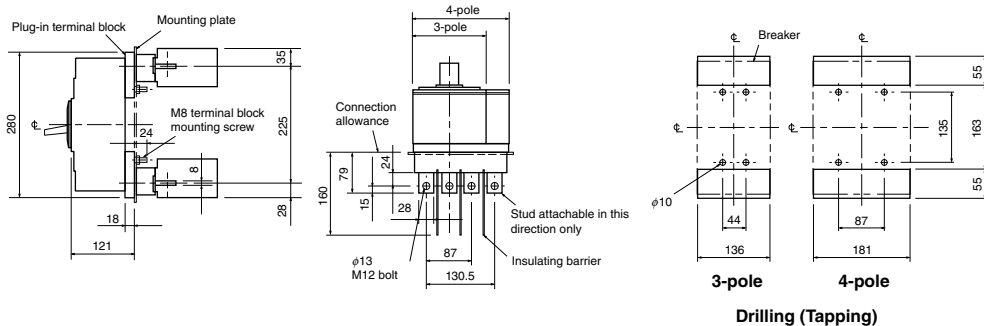

Remark: 1. 2-pole models are 3-pole models with the central pole removed.

## NF400-SEW NF400-HEW NF400-REW



NF400-SEW

Model		NF400-SEW	NF400-HEW	NF400-REW		
Rated current I <sub>n</sub> (A)		Adjustable				
Reference ambient temperature 40 °C		200 225 250 300 350 400				
Number of poles		3	4	3		
Rated insulation voltage U <sub>i</sub> (V)		690	690	690		
Rated short-circuit breaking capacity (kA)	IEC 60947-2 EN 60947-2 (Icu/Ics)	AC	690V	10/10	35/18	-
			500V	30/30	50/50	70/35
			440V	42/42	65/65	125/63
			415V	50/50	70/70	125/63
			400V	50/50	70/70	125/63
			380V	50/50	70/70	125/63
			230V	85/85	100/100	150/75
			200V	85/85	100/100	150/75
			DC	250V	-	-
Standard attached parts		Front connection	Terminal screw: M12 bolt×35 (3-pole: 6pcs, 4-pole: 8pcs) Mounting screw: M6×72 (4pcs) Insulating barrier: (3P: 4pcs, 4P: 6pcs)			
		Rear connection	Terminal screw: M12 bolt×35 (3-pole: 6pcs, 4-pole: 8pcs) Mounting screw: M6×85 (4pcs)			

### Operating Characteristics

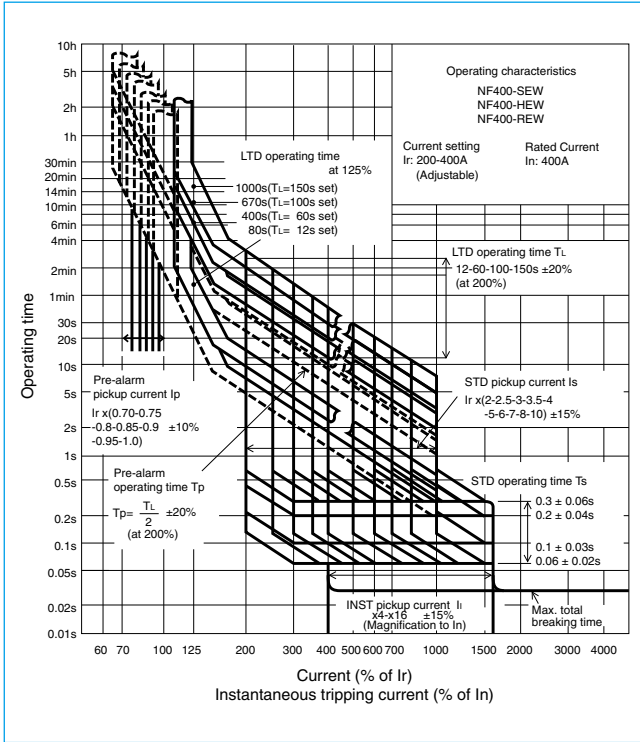

### Internal Accessories

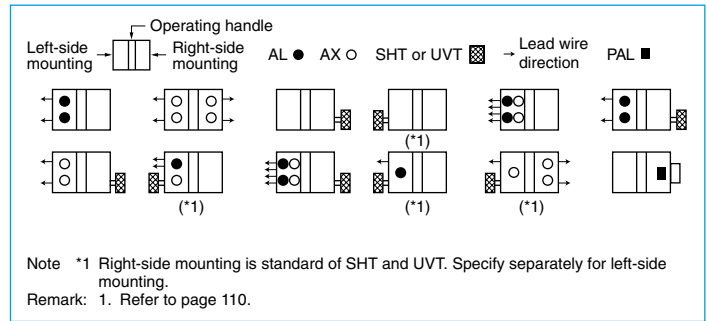

### Current Reducing Curve

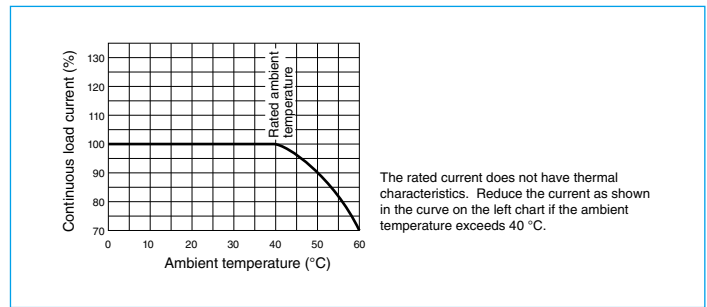

### External Accessories

Accessories	Type name	Reference page	Accessories	Type name	Reference page	
Operating handle	F	F-4S	Terminal cover	Large	TC-L	
	V	V-4S				3P
Mechanical interlock	MI	3P	4P	TCL-4SW4 (*3)	128	
		4P	MI-4SW4	3P		TTC-4SW3
Auxiliary handle	HT	HT-4SW	4P	TTC-4SW4		
			3P	BTC-4SW3 (*4)		
			Rear	4P	BTC-4SW4	
			Handle lock device	HL	HL-4SW	
				HL-S	HLS-4SW	134
			Electrical operation device	NFM	3P	(*1)
					4P	

Notes \*1 Specify the operation method and voltage. Order in combination with the breaker unit.  
\*2 This is for NF400-SEW.  
\*3 This is for NF400-SEW/HEW.  
\*4 This is for NF400-SEW. For rear terminal cover of NF400-HEW/REW, use PTC-4SW3.

Outline Drawing

Front connection

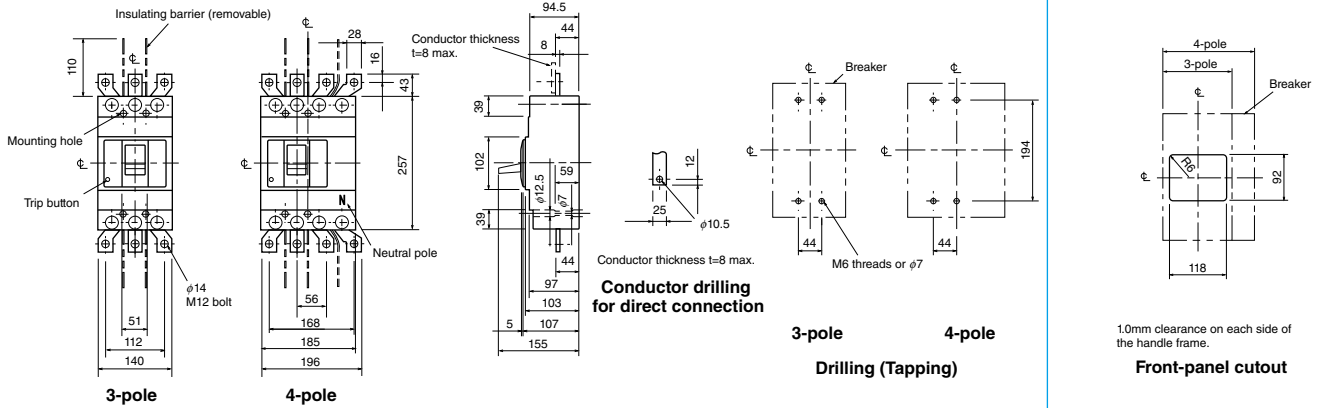

Rear connection

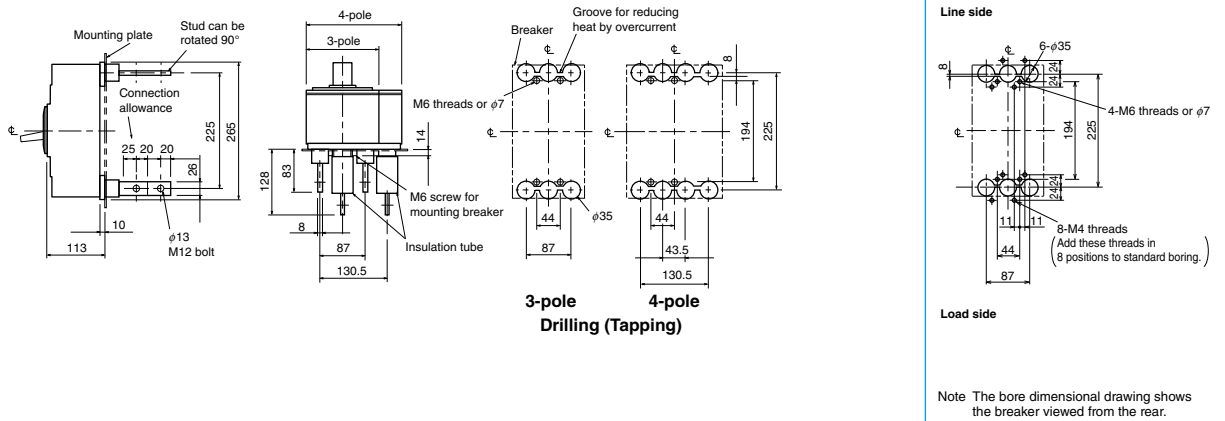

Plug-in

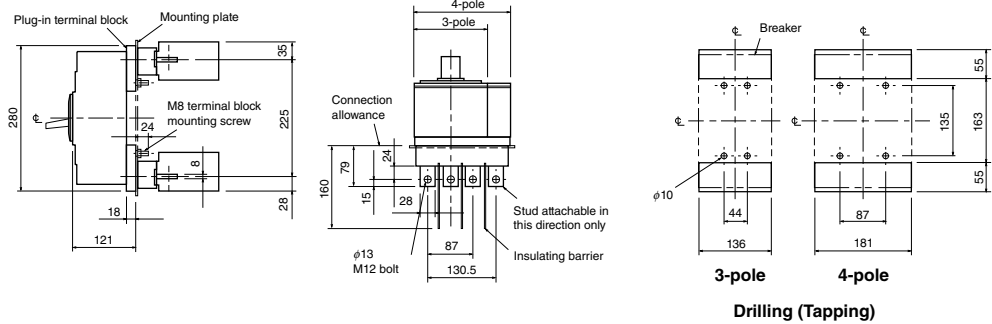

## NF400-UEW



NF400-UEW

Model		NF400-UEW		
Rated current $I_n$ (A) Reference ambient temperature 40°C		Adjustable 200 225 250 300 350 400		
Number of poles		3	4	
Rated insulation voltage $U_i$ (V)		690		
Rated short-circuit breaking capacity (kA)	IEC 60947-2 (Icu/Ics)	AC	690V	-
			500V	170/170
			440V	200/200
			415V	200/200
			400V	200/200
			380V	200/200
			230V	200/200
			200V	200/200
			DC	250V
Standard attached parts (4-pole models are provided with auxiliary handle.)		Front connection	Terminal screw: M12 bolt×35 (3-pole: 6pcs, 4-pole: 8pcs) Mounting screw: 3P M6×65 (2pcs), M6×174 (2pcs) 4P M6×35 (3pcs), M6×132 (2pcs) Insulating barrier: (3P: 4pcs, 4P: 3pcs, )	
		Rear connection	Terminal screw: M12 bolt×35 (3-pole: 6pcs, 4-pole: 8pcs) Mounting screw: 3P M6×72 (2pcs), M6×181 (2pcs) 4P M6×35 (3pcs), M6×132 (2pcs)	

## Operating Characteristics

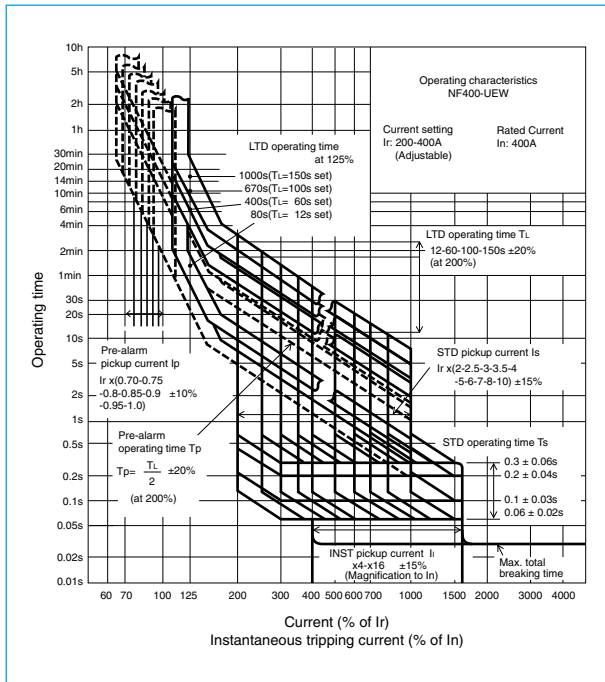

## Internal Accessories

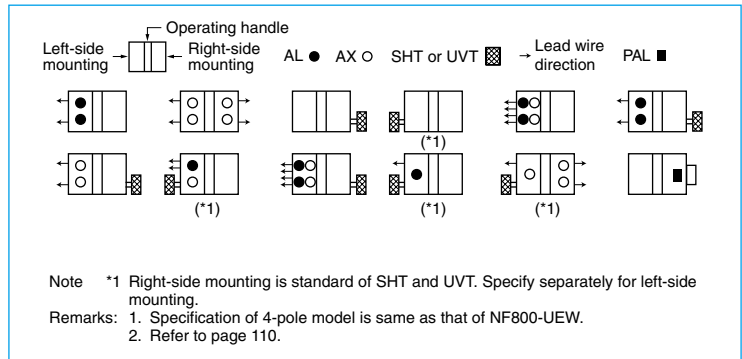

## Current Reducing Curve

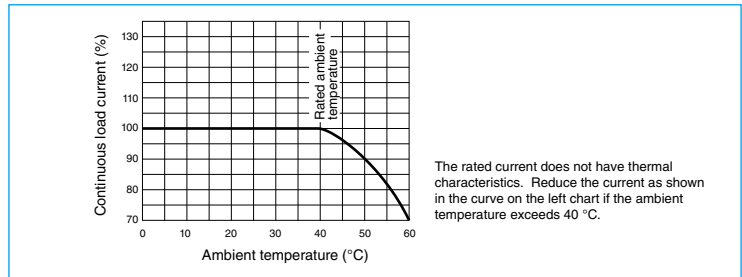

## External Accessories

Accessories	Type name	Reference page	Accessories	Type name	Reference page	
Operating handle	F	F-4U	Terminal cover	Large	3P	TCL-4SW3
	V	V-4U			4P	TCL-8UW4
Mechanical interlock	MI	MI-4SW3		Skeleton	3P	-
	HT	HT-4SW				3P
Auxiliary handle	HT	HT-4SW	Handle lock device	HL	HL-4SW	
				HL-S	HLS-4UW	
			Electrical operation device	(*)	140	

Note \*1 Specify the operation method and voltage. Order in combination with the breaker unit.  
 Remark \*1 Specification of 4-pole model is same as that of NF800-UEW.

Outline Drawing

Front connection

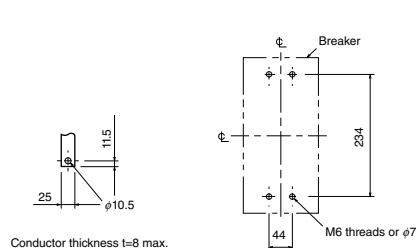
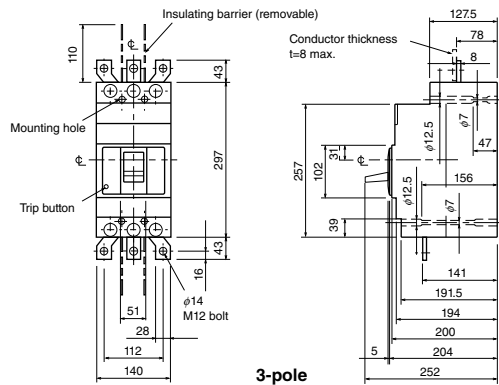

Conductor thickness t=8 max.  
**Conductor drilling for direct connection**

**3-pole Drilling (Tapping)**

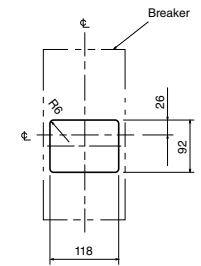

1.0mm clearance on each side of the handle frame.  
**Front-panel cutout**

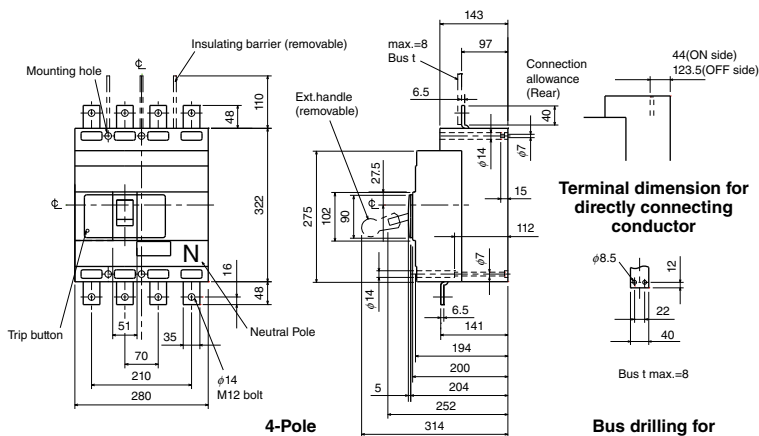

**Terminal dimension for directly connecting conductor**

**Bus drilling for direct connection**

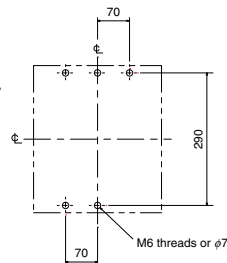

**4-pole Drilling (Tapping)**

Rear connection

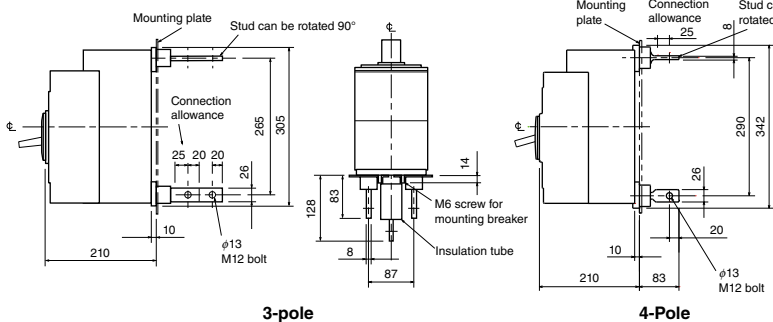

**3-pole**

**4-Pole**

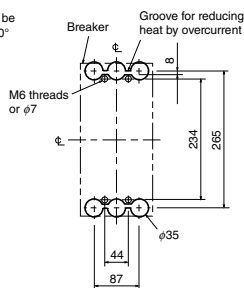

**Drilling (Tapping)**

Boring dimensions for rear connection type barriers (3-pole)

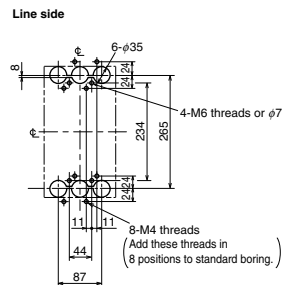

**Load side**

Note The bore dimensional drawing shows the breaker viewed from the rear.

Plug-in

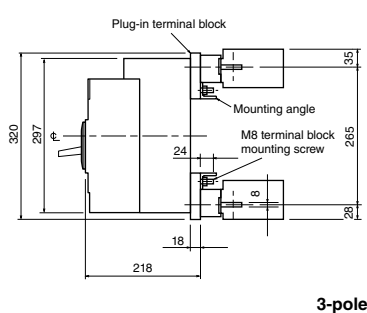

**3-pole**

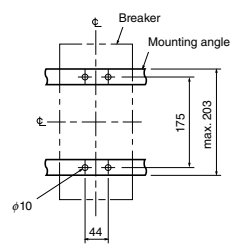
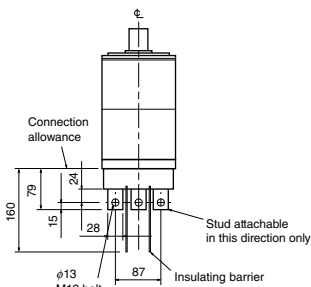

**3-pole Drilling (Tapping)**

## NF630-CW NF630-SW



Model		NF630-CW		NF630-SW	
Rated current In (A) Reference ambient temperature 40°C		500 600 (630)			
Number of poles		2	3	2	3 4
Rated insulation voltage Ui (V)		690		690	
Rated short-circuit breaking capacity (kA)	IEC 60947-2 (Icu/Ics)	AC	690V	-	10/10
			500V	18/9	30/30
			440V	36/18	42/42
			415V	36/18	50/50
			400V	36/18	50/50
			380V	40/20	50/50
			230V	50/25	85/85
			200V	50/25	85/85
	DC (*1)	250V	20/10	40/40	
Standard attached parts		Front connection	Terminal screw: M12 boltx35 (2-pole: 4pcs, 3-pole: 6pcs, 4-pole: 8pcs) Mounting screw: M6x72 (4pcs) Insulating barrier: (2P: 2pcs, 3P: 4pcs, 4P: 6pcs)		
		Rear connection	Terminal screw: M12 boltx35 (2-pole: 4pcs, 3-pole: 6pcs, 4-pole: 8pcs) Mounting screw: M6x85 (4pcs)		

Note \*1 When wired as shown at the bottom of page 18, 3-pole models can be used for up to 400VDC, and 4-pole models for up to 500VDC.

## Operating Characteristics

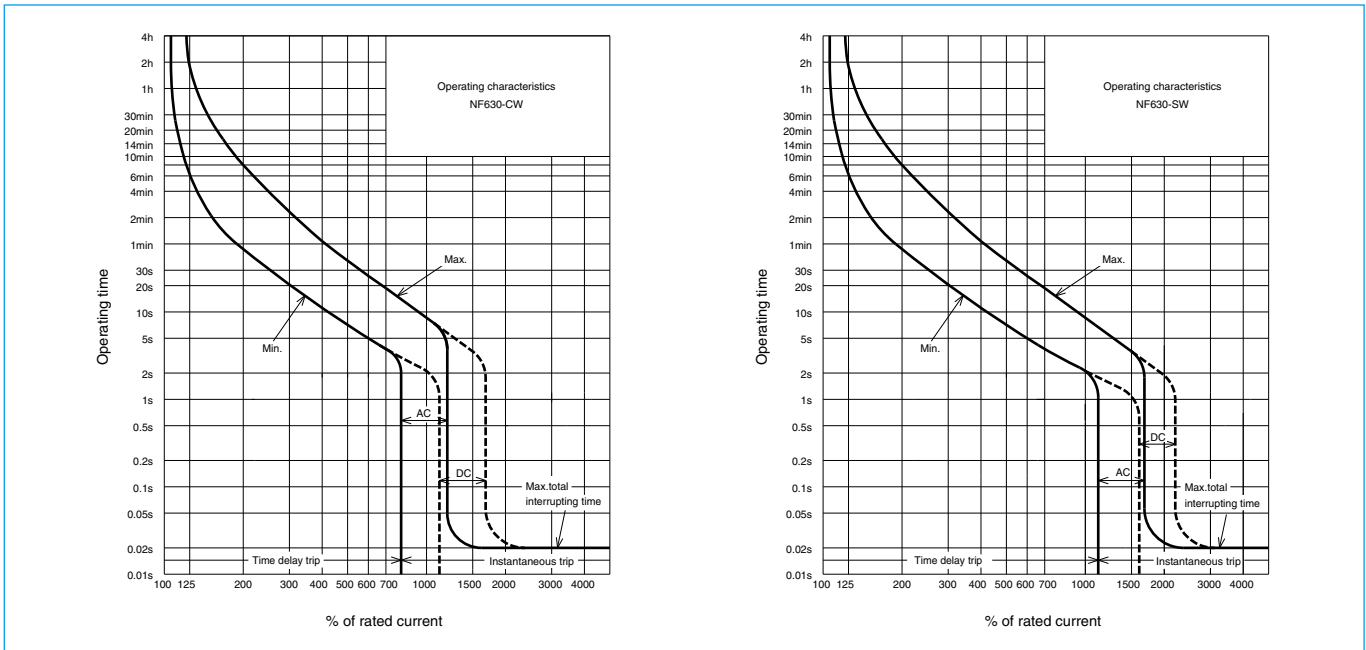

## Internal Accessories

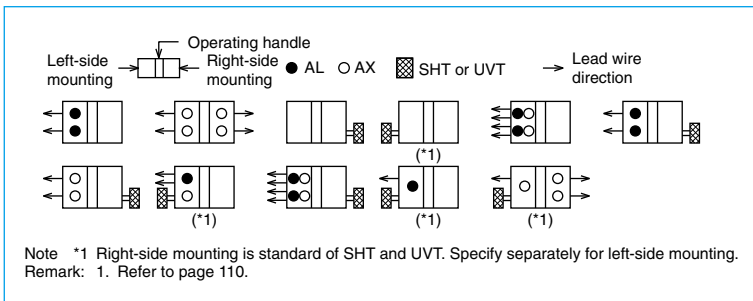

## Temperature Compensation Curve

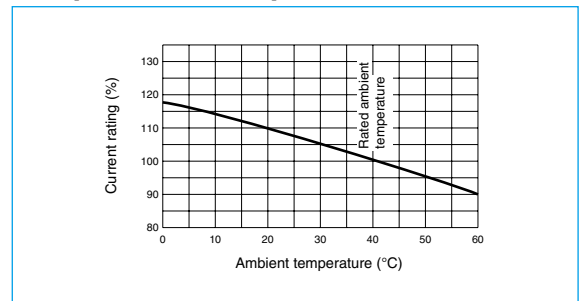

## External Accessories

Accessories		Type name	Reference page	Accessories		Type name	Reference page
Operating handle	F	F-4S	123	Terminal cover	Large	TC-L 2, 3P	TCL-4SW3
	V	V-4S	125			4P	TCL-4SW4
Mechanical interlock	MI	2, 3P	136		Skeleton	2, 3P	TTC-4SW3
		4P				TTC-4SW4	
Auxiliary handle	HT	135		Rear	2, 3P	BTC-4SW3	
					4P	BTC-4SW4	
Handle lock device				HL		HL-4SW	134
				HL-S		HL-S	
Electrical operation device				NFM	3P	(*1)	140
					4P		

Note \*1 Specify the operation method and voltage. Order in combination with the breaker unit.

Outline Drawing

Front connection

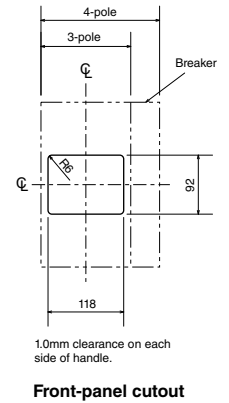
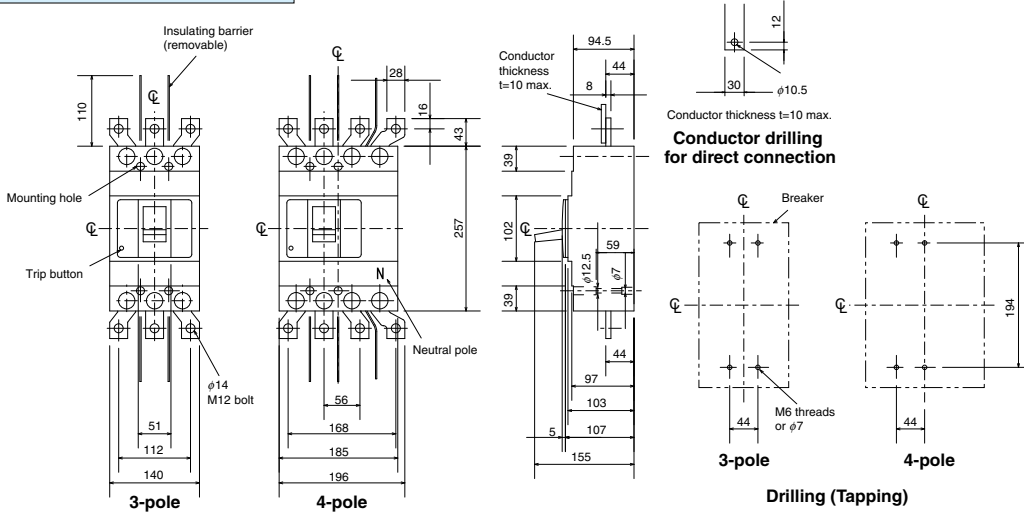

Rear connection

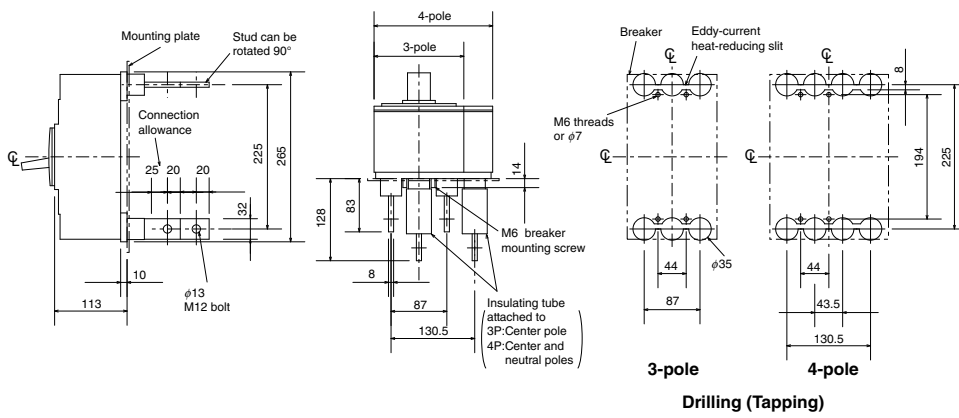

Boring dimensions for rear connection type barriers (3-pole)

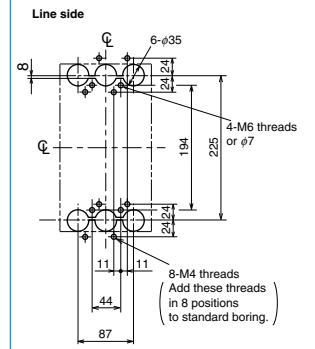

Note: The bore dimensional drawing shows the breaker viewed from the rear.

Plug-in

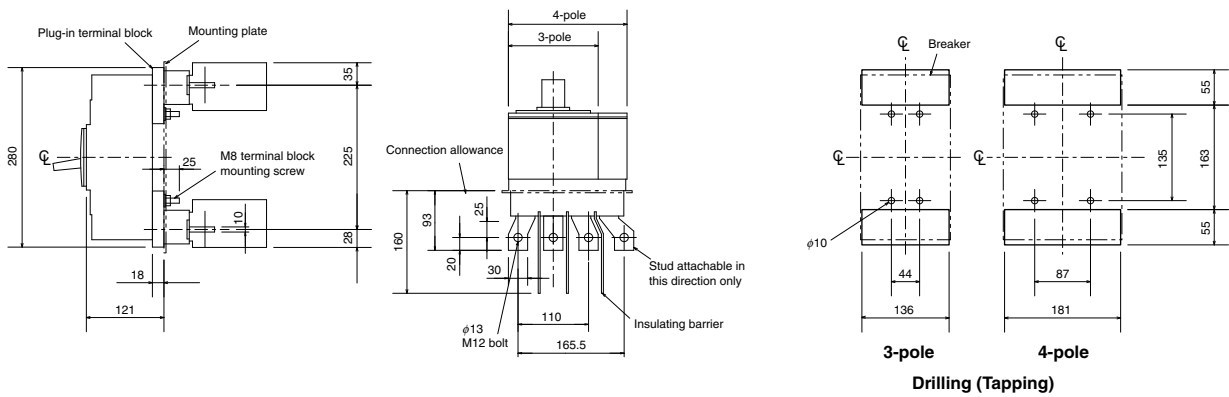

Remark: 1. 2-pole models are 3-pole models with the central pole removed.

## NF630-SEW NF630-HEW NF630-REW



NF630-SEW

Model		NF630-SEW	NF630-HEW	NF630-REW		
Rated current I <sub>n</sub> (A) Reference ambient temperature 40°C		Adjustable 300 350 400 500 600 630				
Number of poles		3	4	3		
Rated insulation voltage U <sub>i</sub> (V)		690	690	690		
Rated short-circuit breaking capacity (kA)	IEC 60947-2 (Icu/Ics)	AC	690V	10/10	35/18	-
			500V	30/30	50/50	70/35
			440V	42/42	65/65	125/63
			415V	50/50	70/70	125/63
			400V	50/50	70/70	125/63
			380V	50/50	70/70	125/63
			230V	85/85	100/100	150/75
			200V	85/85	100/100	150/75
Standard attached parts	Front connection	Terminal screw: M12 bolt×35 (3-pole: 6pcs, 4-pole: 8pcs) Mounting screw: M6×72 (4pcs) Insulating barrier: (3P: 4pcs, 4P: 6pcs)				
		Terminal screw: M12 bolt×35 (3-pole: 6pcs, 4-pole: 8pcs) Mounting screw: M6×85 (4pcs)				

### Operating Characteristics

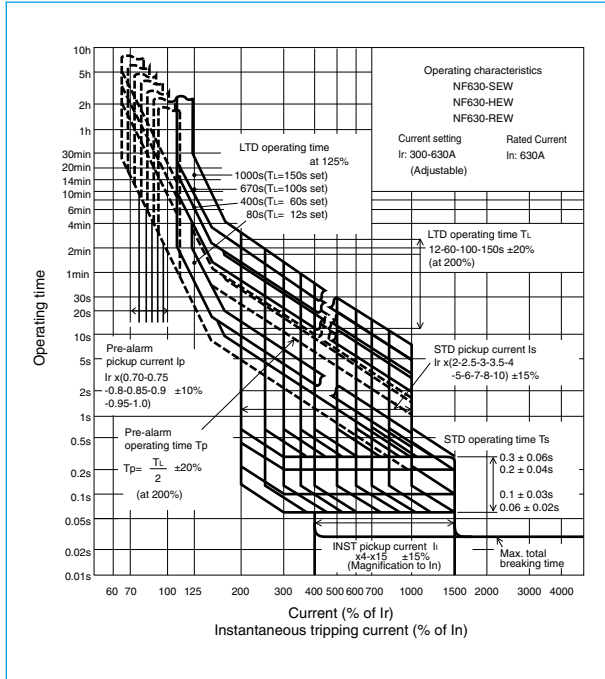

### Internal Accessories

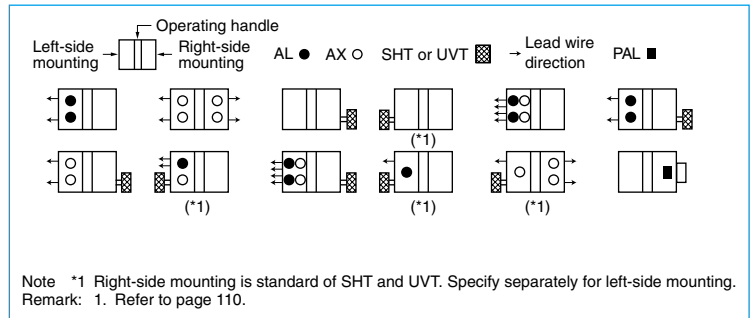

### Current Reducing Curve

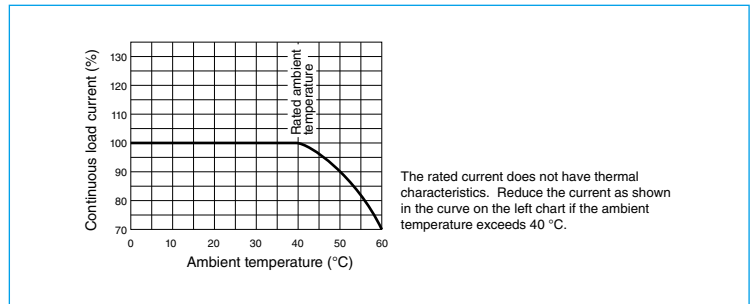

### External Accessories

Accessories		Type name	Reference page	Accessories		Type name	Reference page	
Operating handle	F	F-4S	123	Terminal cover	Large	TC-L	3P TCL-4SW3 (*2)	
	V	V-4S	125			4P TCL-4SW4 (*2)		
Mechanical interlock	MI	3P	MI-4SW3		Skeleton	TTC	3P	TTC-4SW3
		4P	MI-4SW4				4P	TTC-4SW4
Auxiliary handle	HT	HT-4SW			Rear	BTC	3P	BTC-4SW3 (*3)
							4P	BTC-4SW4
Handle lock device					HL		HL-4SW	
					HL-S		HLS-4SW	
Electrical operation device				NFM	3P	(*1)		
					4P			

Notes \*1 Specify the operation method and voltage. Order in combination with the breaker unit.  
\*2 This is for NF630-SEW.  
\*3 This is for NF630-SEW. For rear terminal cover of NF630-HEW/REW, use PTC-4SW3.

Outline Drawing

Front connection

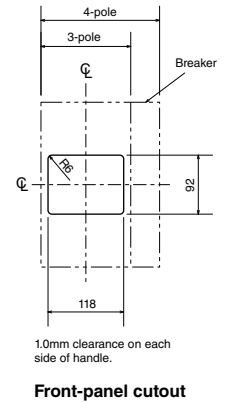
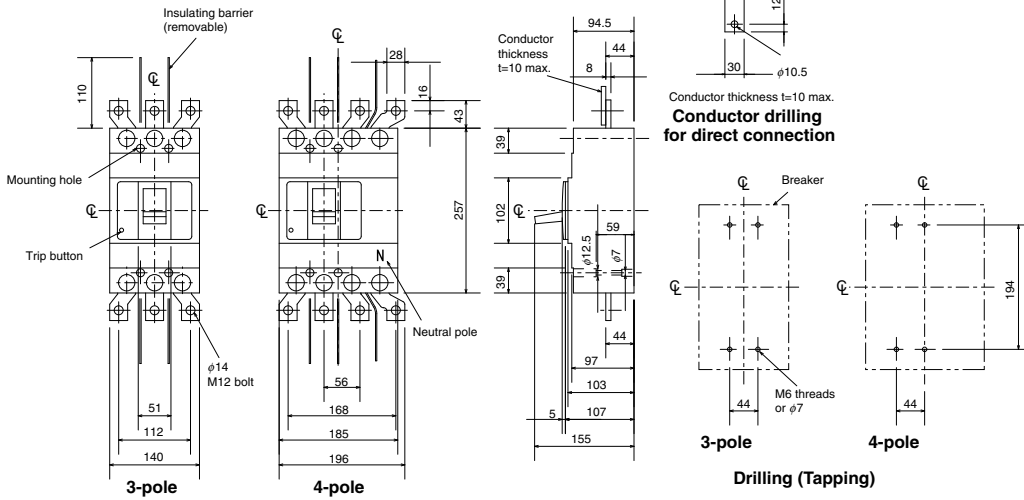

Rear connection

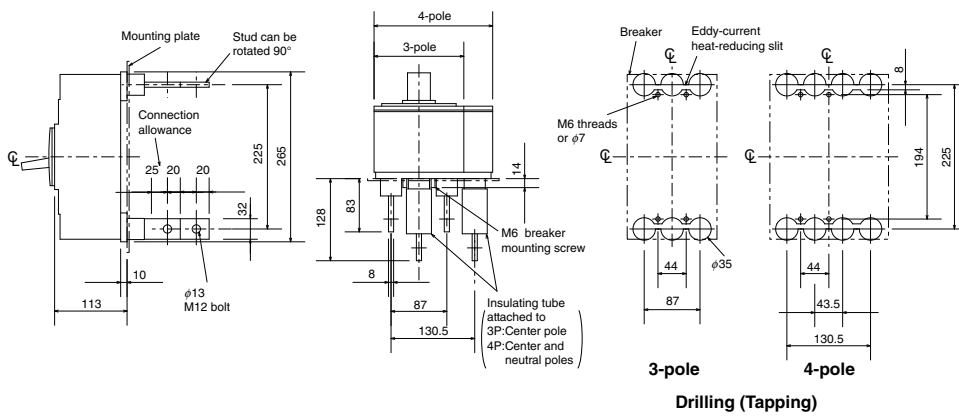

Boring dimensions for rear connection type barriers (3-pole)

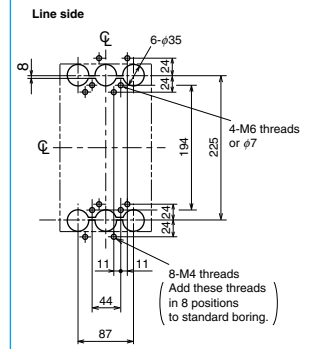

Note The bore dimensional drawing shows the breaker viewed from the rear.

Plug-in

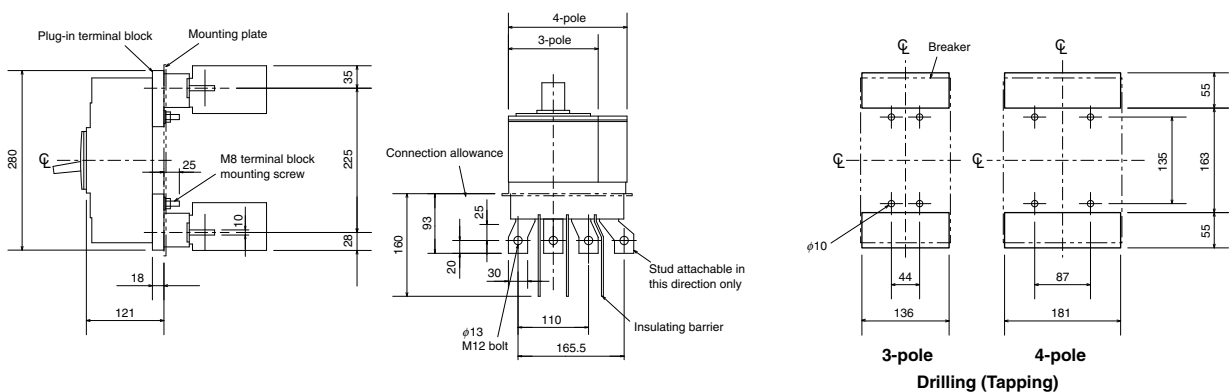

## NF800-CEW NF800-SEW NF800-HEW NF800-REW



NF800-SEW

Model		NF800-CEW	NF800-SEW	NF800-HEW	NF800-REW		
Rated current I <sub>n</sub> (A)		Adjustable					
Reference ambient temperature 40°C		400	450	500	600 700 800		
Number of poles		3	3	4	3		
Rated insulation voltage U <sub>i</sub> (V)		690	690	690	690		
Rated short-circuit breaking capacity (kA)	IEC 60947-2 (Icu/Ics)	AC	690V	-	10/10	15/15	-
			500V	18/9	30/30	50/50	70/35
			440V	36/18	42/42	65/65	125/63
			415V	36/18	50/50	70/70	125/63
			400V	36/18	50/50	70/70	125/63
			380V	40/20	50/50	70/70	125/63
			230V	50/25	85/85	100/100	150/75
			200V	50/25	85/85	100/100	150/75
			DC	250V	-	-	-
Standard attached parts (4-pole models are provided with auxiliary handle.)		Front connection	Terminal screw: M12 boltx35 (3-pole: 12pcs, 4-pole: 16pcs) Mounting screw: M6x35 (4pcs) Insulating barrier: (3P: 2pcs, 4P: 3pcs)				
		Rear connection	Terminal screw: M12 boltx40 (3-pole: 12pcs, 4-pole: 16pcs) Mounting screw: M6x40 (4pcs)				

### Operating Characteristics

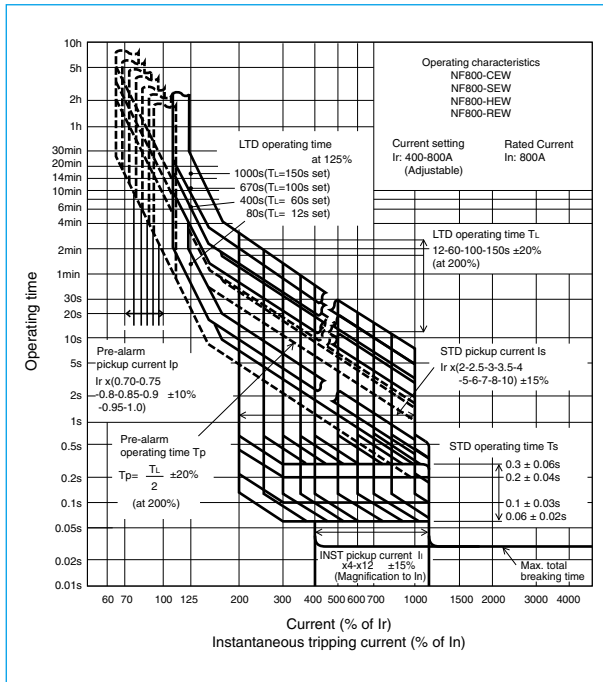

### Internal Accessories

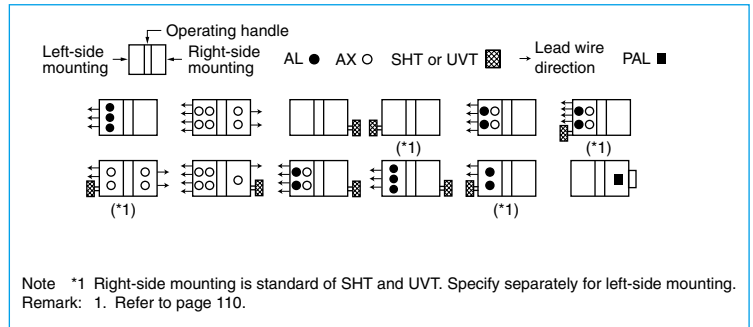

### Current Reducing Curve

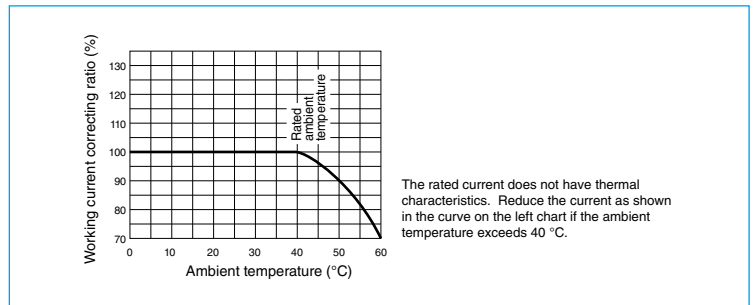

### External Accessories

Accessories		Type name	Reference page	Accessories		Type name	Reference page	
Operating handle	F	F-8S	123	Terminal cover	Large	TC-L 3P	TCL-8SW3	
	V	V-8S	125			TC-L 4P	TCL-8SW4	
Mechanical interlock	MI	3P	136		Skeleton	TTC	3P	TTC-8SW3
		4P					TTC-8SW4	
Auxiliary handle	HT	HT-4SW 135			Rear	BTC	3P	BTC-8SW3
							4P	BTC-8SW4
Handle lock device				HL		HL-4SW	134	
						HL-S		HLS-8SW
Electrical operation device				NFM	3P	(*1)	140	
					4P			

Note \*1 Specify the operation method and voltage. Order in combination with the breaker unit.



## NF800-SDW



NF800-SDW

Model		NF800-SDW		
Rated current In (A) Reference ambient temperature 40°C		(700) 800		
Number of poles		2		
Rated insulation voltage Ui (V)		690		
Rated short-circuit breaking capacity (kA)	IEC 60947-2 (Icu/Ics) Time constant not larger than 10ms	AC	690V	-
			500V	-
			440V	-
			415V	-
			400V	-
			380V	-
			230V	-
			200V	-
		DC	250V (*1)	40/40
Standard attached parts (4-pole models are provided with auxiliary handle.)		Front connection	Terminal screw: M12 boltx35 (2-pole: 8pcs, 3-pole: 12pcs, 4-pole: 16pcs) Mounting screw: M6x35 (4pcs) Insulating barrier: (2P: 1pc, 3P: 2pcs, 4P: 3pcs)	
		Rear connection	Terminal screw: M12 boltx40 (2-pole: 8pcs, 3-pole: 12pcs, 4-pole: 16pcs) Mounting screw: M6x40 (4pcs)	

Note \*1 The standard specifications for NF800-SDW are 2-pole.  
For DC special voltage use, we also have 3-pole and 4-pole models.

### Operating Characteristics

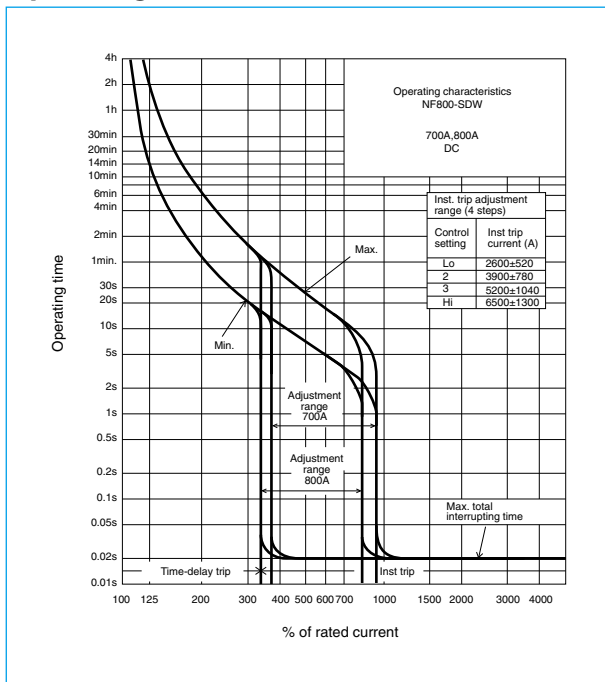

### Internal Accessories

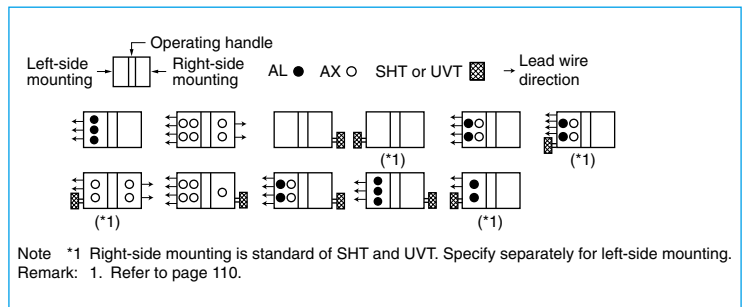

### Temperature Compensation Curve

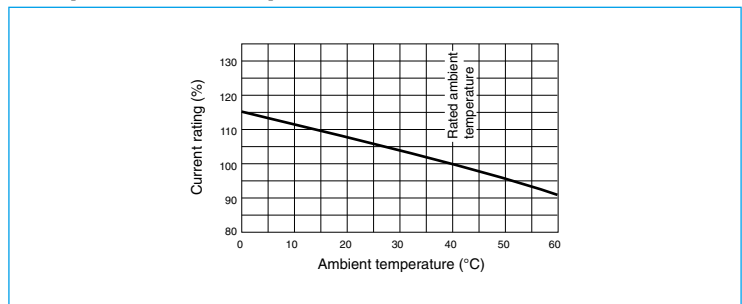

## 7 External Accessories

Accessories		Type name	Reference page	Accessories		Type name	Reference page	
Operating handle	F	F-8S	123	Terminal cover	Large	2, 3P	TCL-8SW3	
	V	V-8S	125			4P	TCL-8SW4	
Mechanical interlock	MI	2, 3P	136		Skeleton	TTC	2, 3P	TTC-8SW3
		4P					TTC-8SW4	
Auxiliary handle	HT	135			Rear	BTC	2, 3P	BTC-8SW3
							4P	BTC-8SW4
Handle lock device					HL		HL-4SW	
					HL-S		HLS-8SW	
Electrical operation device				NFM	2, 3P	(*1)		
					4P			

Note \*1 Specify the operation method and voltage. Order in combination with the breaker unit.

Outline Drawing

Front connection

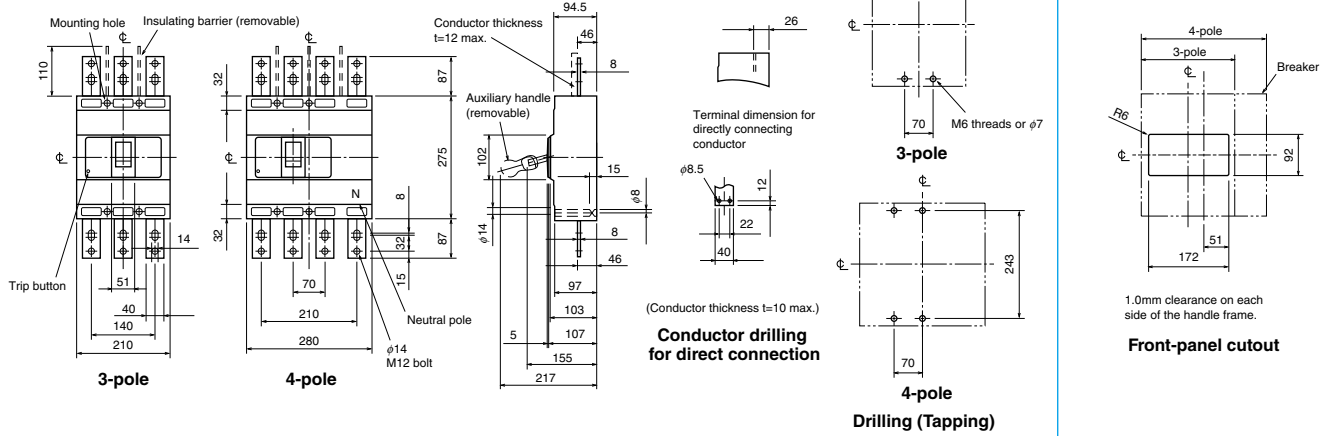

Rear connection

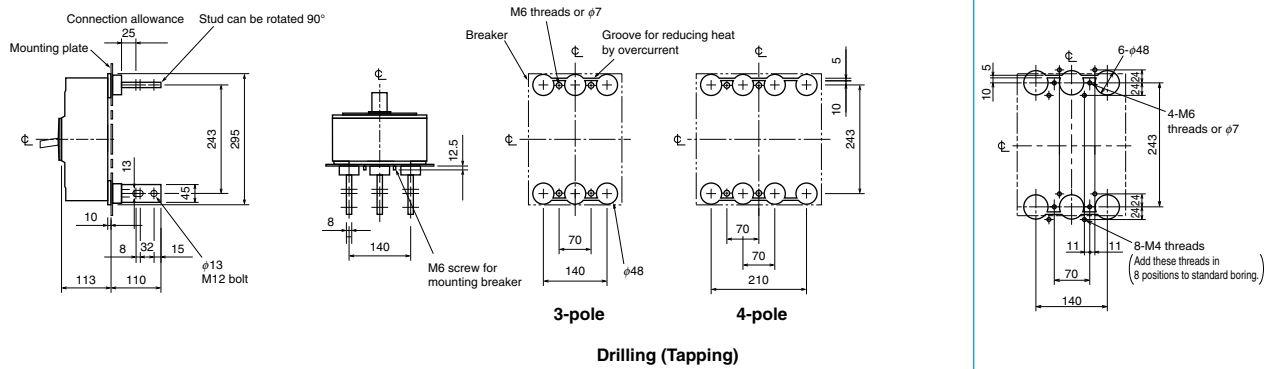

Plug-in

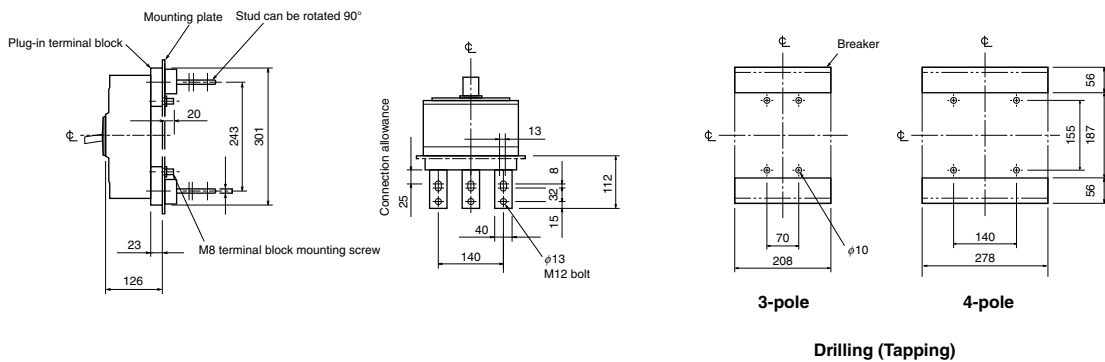

Remarks: 1. Standard specification of NF800-SDW is 2-pole model. 3-pole and 4-pole models are available for DC special voltage.  
 2. 2-pole models are 3-pole models with the central pole removed.

## NF800-U EW



NF800-U EW

Model		NF800-U EW		
Rated current I <sub>n</sub> (A)		Adjustable		
Reference ambient temperature 40 °C		400 450 500 600 700 800		
Number of poles		3	4	
Rated insulation voltage U <sub>i</sub> (V)		690		
Rated short-circuit breaking capacity (kA)	IEC 60947-2 (Icu/Ics)	AC	690V	35/35
			500V	170/170
			440V	200/200
			415V	200/200
			400V	200/200
			380V	200/200
			230V	200/200
			200V	200/200
Standard attached parts (4-pole models are provided with auxiliary handle.)	Front connection	Terminal screw: M12 bolt×35 (3-pole: 12pcs, 4-pole: 16pcs) Mounting screw: 3P: M6×35, M6×132 (2pcs each) 4P: M6×35 (3pcs), M6×132 (2pcs) Insulating barrier: (3P: 2pcs, 4P: 3pcs)		
		Rear connection	Terminal screw: M12 bolt×40 (3-pole: 12pcs, 4-pole: 16pcs) Mounting screw: 3P: M6×40, M6×137 (2pcs each) 4P: M6×40 (3pcs), M6×137 (2pcs)	

## Operating Characteristics

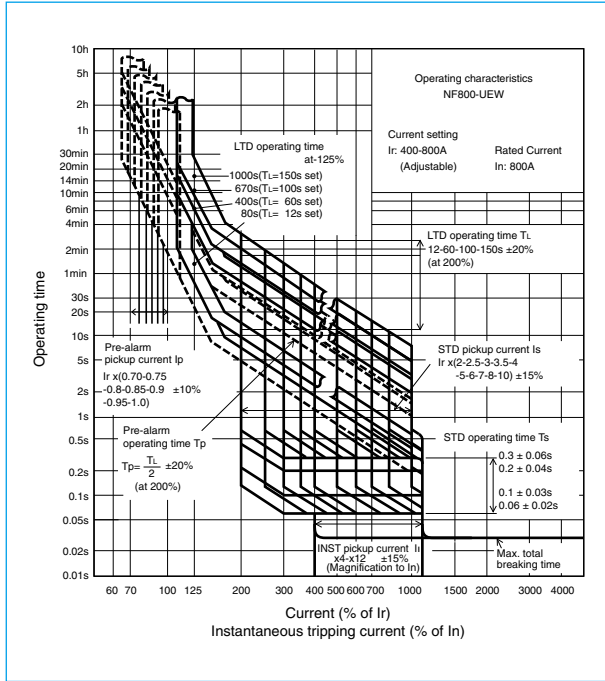

## Internal Accessories

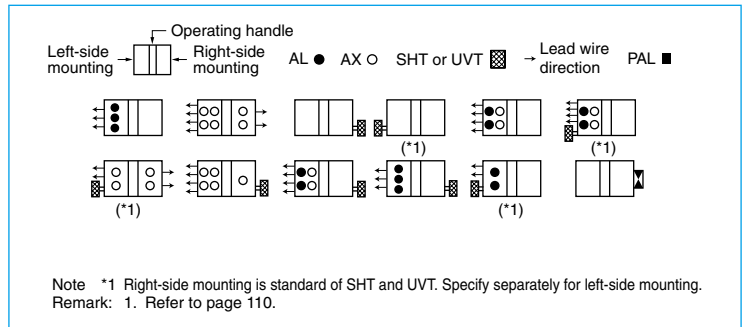

## Current Reducing Curve

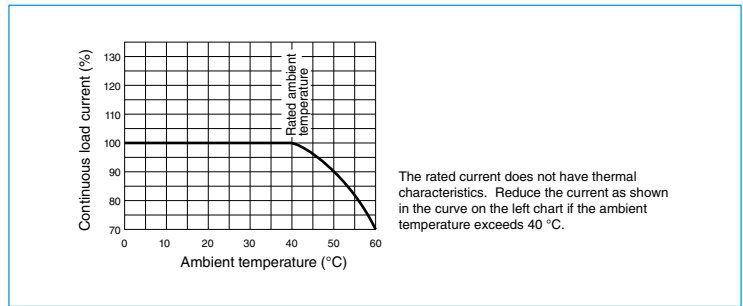

## External Accessories

Accessories		Type name	Reference page	Accessories		Type name	Reference page	
Operating handle	F	F-8U	123	Terminal cover	Large	3P	TCL-8UW3	
	V	-	125			4P	TCL-8UW4	
Mechanical interlock	MI	3P	MI-8SW3		Skeleton	TTC	3P	-
		4P	MI-8SW4				4P	-
Auxiliary handle	HT	HT-4SW	135	Rear	BTC	3P	BTC-8SW3	
						4P	BTC-8SW4	
Handle lock device	HL			Handle lock device	HL		HL-4SW	
							HL-S	HLS-8UW
Electrical operation device				Electrical operation device		(*1)	140	

Note \*1 Specify the operation method and voltage. Order in combination with the breaker unit.

Outline Drawing

**Front connection**

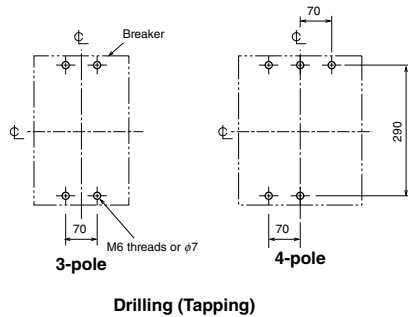
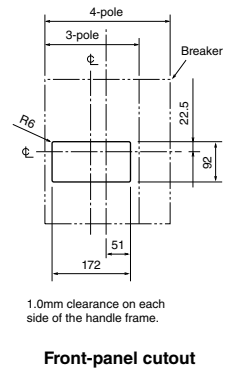
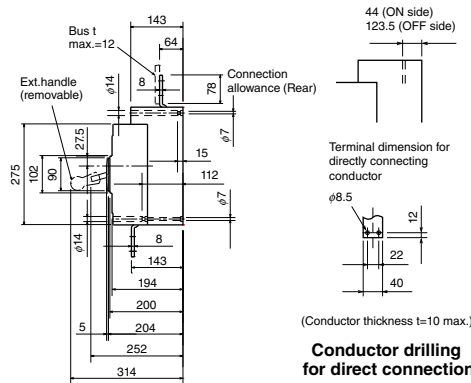
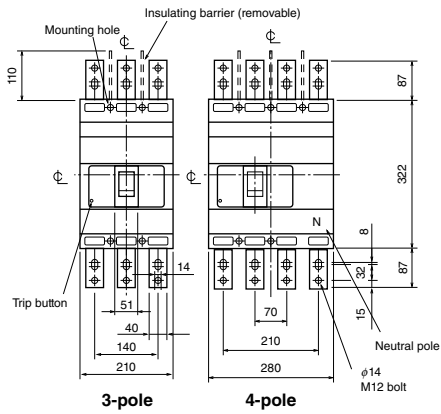

Drilling (Tapping)

**Rear connection**

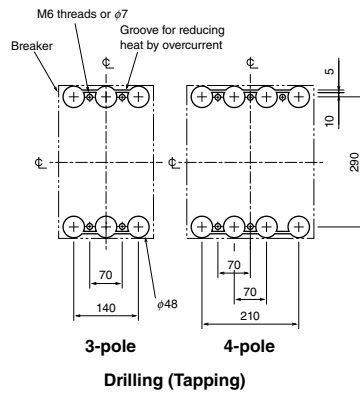
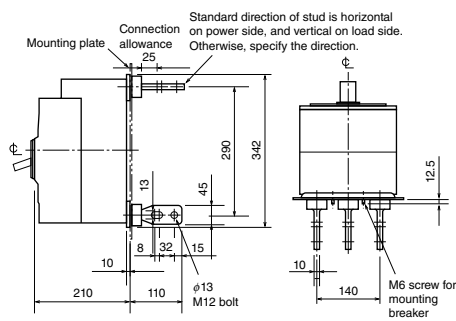

Drilling (Tapping)

**Boring dimensions for rear connection type barriers (3-pole)**

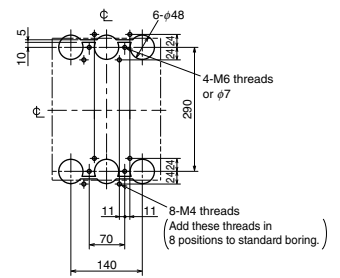

## NF1000-SEW NF1250-SEW



NF1250-SEW

Model		NF1000-SEW	NF1250-SEW		
Rated current I <sub>n</sub> (A) Reference ambient temperature 40 °C		Adjustable 500 600 700 800 900 1000	Adjustable 600 700 800 1000 1200 1250		
Number of poles		3      4	3      4		
Rated insulation voltage U <sub>i</sub> (V)		690	690		
Rated short-circuit breaking capacity (kA)	IEC 60947-2 (Icu/Ics)	AC	690V	25/13	25/13
			500V	65/33	65/33
			440V	85/43	85/43
			415V	85/43	85/43
			400V	85/43	85/43
			380V	85/43	85/43
			230V	125/63	125/63
			200V	125/63	125/63
Standard attached parts		DC	250V	-	-
		Front connection	Terminal screw: M12 boltx50 (3-pole: 12pcs, 4-pole: 16pcs) Mounting screw: M8x40 (4pcs) Insulating barrier: (3P: 2pcs, 4P: 3pcs) Auxiliary handle: (1pc)		
		Rear connection	Terminal screw: M12 boltx45 (3-pole: 12pcs, 4-pole: 16pcs) Mounting screw: M8x40 (4pcs) Insulating barrier: (3P: 2pcs, 4P: 4pcs) Auxiliary handle: (1pc)		

### Operating Characteristics

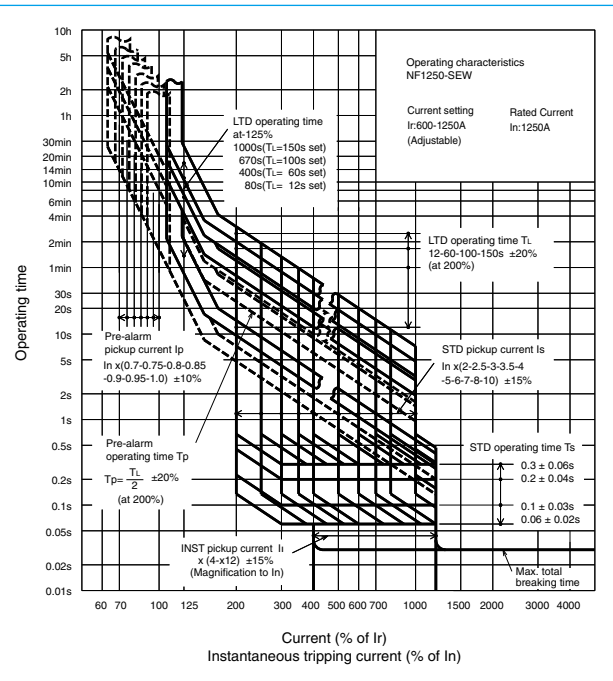
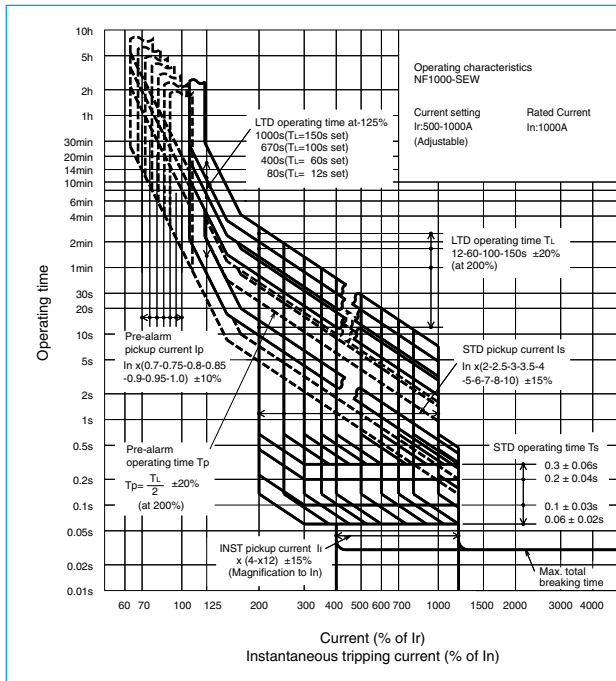

### Internal Accessories

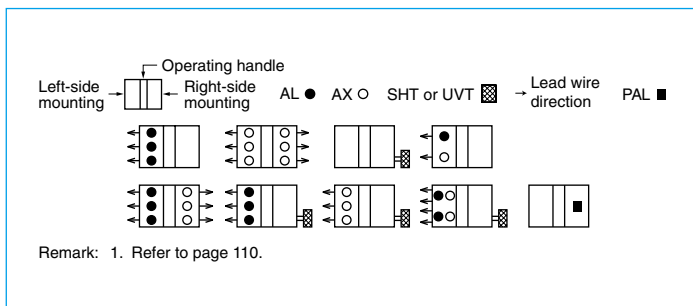

### Current Reducing Curve

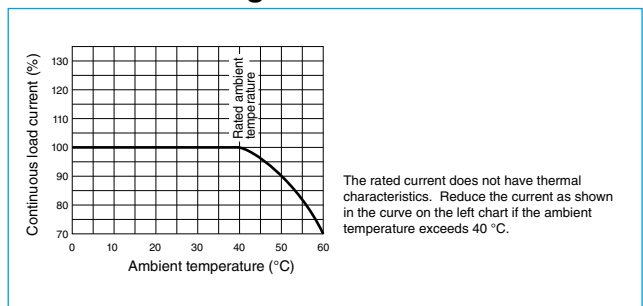

### External Accessories

(An order for ☆ should be placed at the same time as an order of circuit breaker main body.)

Accessories	Type name	Reference page	Accessories	Type name	Reference page
Operating handle	F	123	Auxiliary handle	HT	HT-10SW
			4P	F10SW4P	
Mechanical interlock	MI	136	Handle lock device	HL	HL (☆)
			3P	MI-10SW3	
			4P	TCL-10SW4	
			Large terminal cover	TC-L	
				3P	
				4P	
			Electrical operation device	NFM	(*)
				3P	
				4P	

Note \*1 Specify the operation method and voltage. Order in combination with the breaker unit.

Outline Drawing

**Front connection**

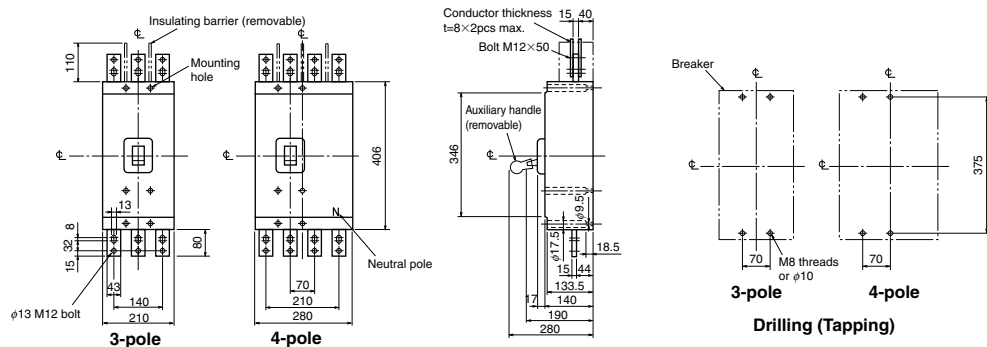

**Rear connection**

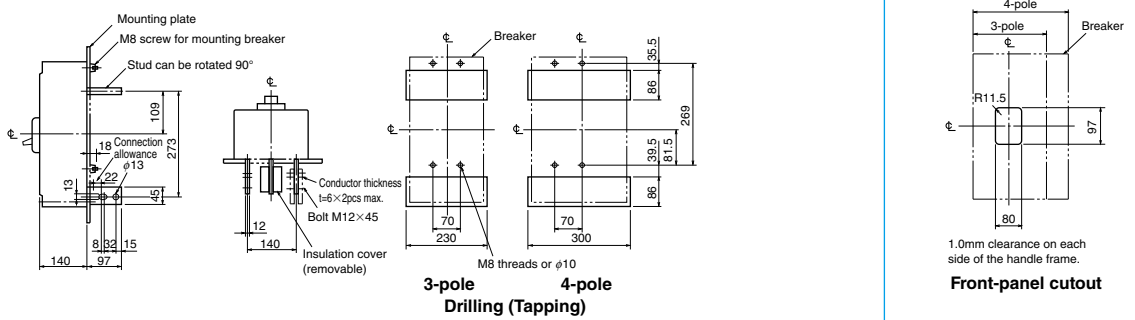

**Plug-in**

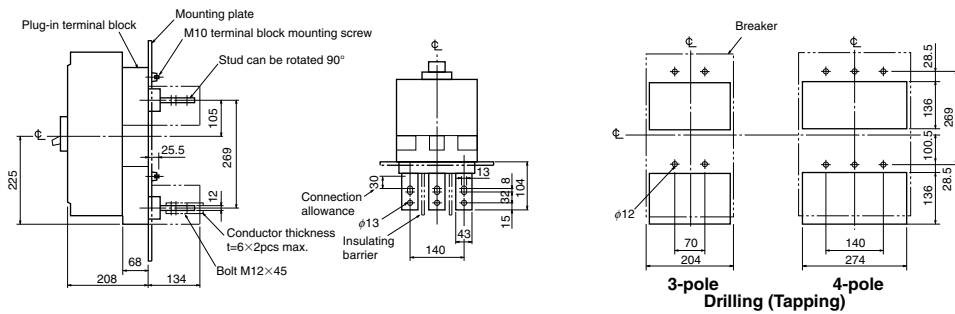

## NF1250-SDW



Model		NF1250-SDW		
Rated current I <sub>n</sub> (Amp.) Reference ambient temperature 40°C		1000 1200 1250		
Number of poles		2		
Rated insulation voltage U <sub>i</sub> (V)		690		
Rated short-circuit breaking capacity (kA)	IEC 60947-2 (Icu/Ics) Time constant not large than 10ms	AC	690V	-
			500V	-
			440V	-
			415V	-
			400V	-
			380V	-
			230V	-
			200V	-
		DC	250V (*1)	40/20
Standard Attached parts		Front connection	Terminal screw: M12 bolt×50 (2-pole: 8pcs, 3-pole: 12pcs) Mounting screw: M8×40 (4pcs) Insulating barrier: (2P: 1pc, 3P: 2pcs, 4P: 3pcs) Auxiliary handle: (1pc)	
		Rear connection	Terminal screw: M12 bolt×45 (2-pole: 8pcs, 3-pole: 12pcs) Mounting screw: M8×40 (4pcs) Insulating barrier: (3P: 2pcs, 4P: 4pcs) Auxiliary handle: (1pc)	

Note \*1 The standard specifications for NF1250-SDW are 2-pole.  
For DC special voltage use, we also have 3-pole model.

## Operating Characteristics

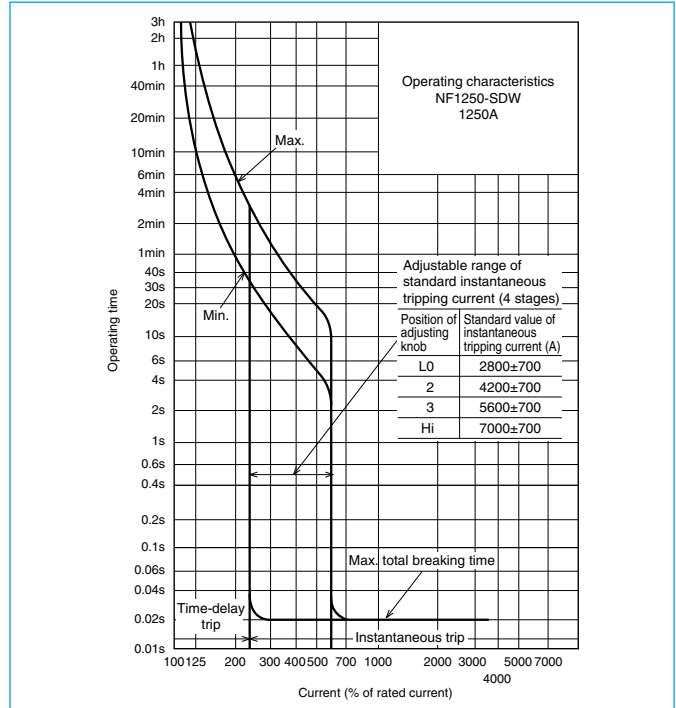
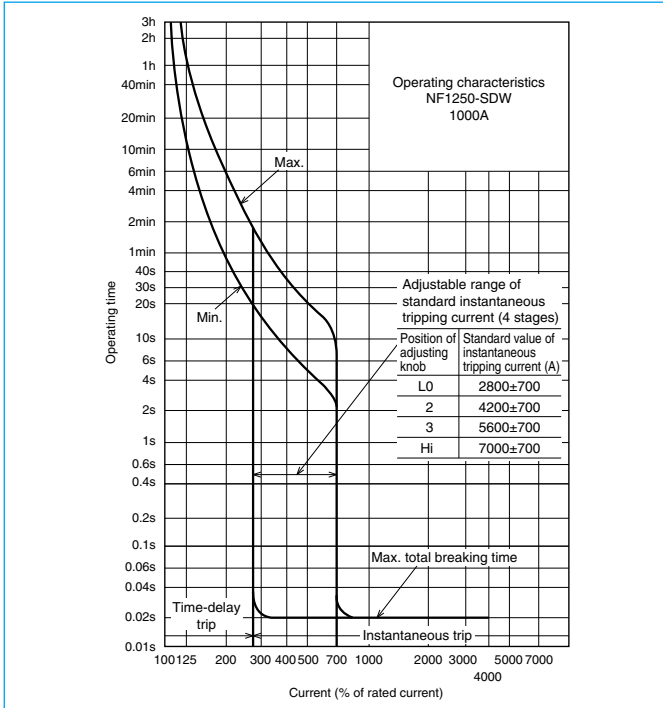

## Internal Accessories

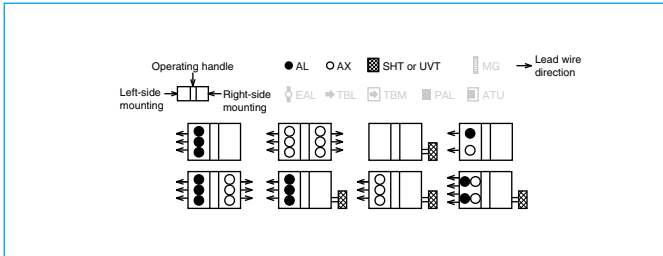

## Temperature Compensation Curve

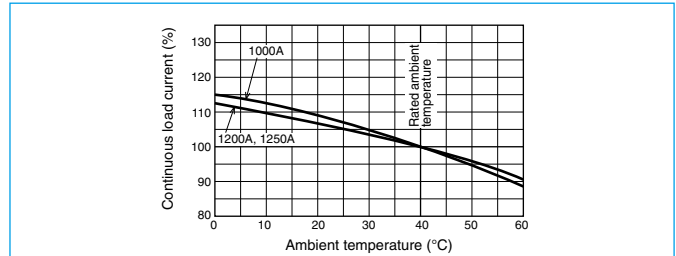

## External Accessories

(An order for ☆ should be placed at the same time as an order of circuit breaker main body.)

Accessories			Type name	Reference page	Accessories		Type name	Reference page	
Operating handle	F	2, 3P	F10SW	123	Auxiliary handle	HT	HT-10SW	135	
		4P	F10SW4P		Handle lock device	HL	HL (☆)	134	
Mechanical interlock	MI	2, 3P	MI-10SW3	136	Large terminal cover	TC-L	2, 3P	TCL-10SW3	128
		4P	MI-10SW4				4P	TCL-10SW4	
					Electrical operation device	NFM	2, 3P 4P	(☆)	140

Note \*1 Specify the operation method and voltage. Order in combination with the breaker unit.



## NF1600-SEW



NF1600-SEW

Model		NF1600-SEW		
Rated current $I_n$ (A)		Adjustable		
Reference ambient temperature 40°C		800 1000 1200 1400 1500 1600		
Number of poles		3	4	
Rated insulation voltage $U_i$ (V)		690		
Rated short-circuit breaking capacity (kA)	IEC 60947-2 (Icu/Ics)	AC	690V	25/13
			500V	65/33
			440V	85/43
			415V	85/43
			400V	85/43
			380V	85/43
			230V	125/63
			200V	125/63
Standard attached parts		DC	-	
		Front connection	Terminal screw: M10 bolt×65 (3-pole: 24pcs, 4-pole: 32pcs) Mounting screw: M8 × 40 (4pcs) Insulating barrier: (3P: 2pcs, 4P: 3pcs) Auxiliary handle: (1pc)	
		Rear connection	Terminal screw: M10 bolt×50 (3-pole: 24pcs, 4-pole: 32pcs) Mounting screw: M8 × 40 (4pcs) Auxiliary handle: (1pc)	

### Operating Characteristics

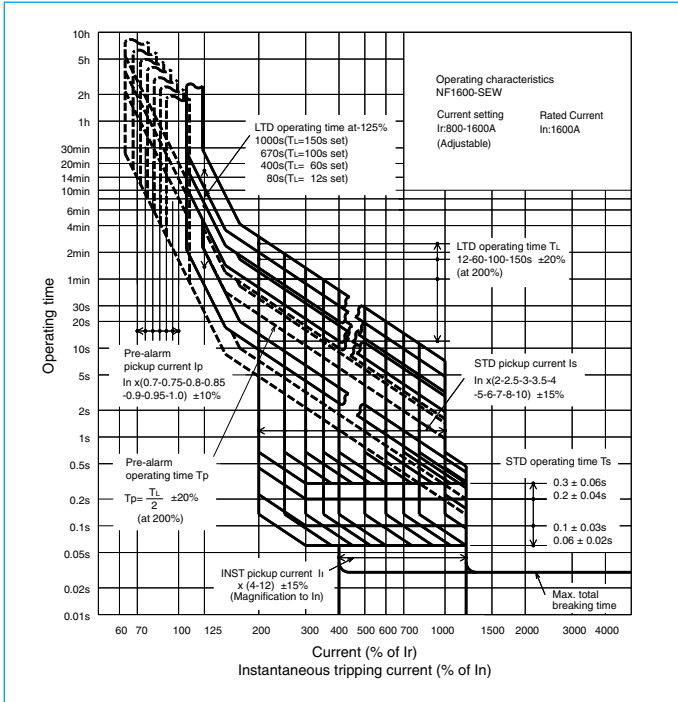

### Internal Accessories

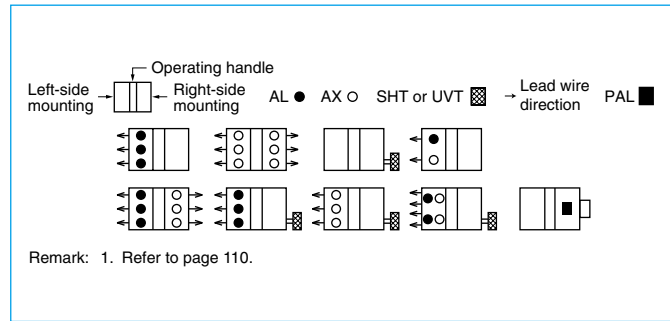

### Current Reducing Curve

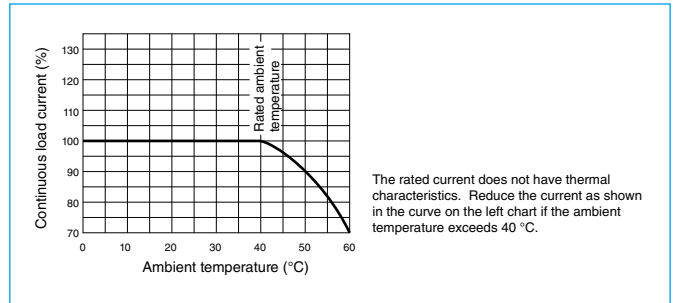

### External Accessories

(An order for ☆ should be placed at the same time as an order of circuit breaker main body.)

Accessories		Type name	Reference page	Accessories		Type name	Reference page
Operating handle	F	3P F10SW	123	Auxiliary handle	HT	HT-10SW	135
		4P F10SW4P		Handle lock device	HL	HL (☆)	134
Mechanical interlock	MI	3P MI-16SW3	136	Electrical operation device	NFM	3P	(*1)
		4P MI-16SW4				4P	

Note \*1 Specify the operation method and voltage. Order in combination with the breaker unit.



## NF1600-SDW



NF1600-SDW

Model		NF1600-SDW		
Rated current I <sub>n</sub> (Amp.) Reference ambient temperature 40°C		1600		
Number of poles		2		
Rated insulation voltage U <sub>i</sub> (V)		690		
Rated short-circuit breaking capacity (kA)	IEC 60947-2 (Icu/Ics) Time constant not large than 10msec	AC	690V	-
			500V	-
			440V	-
			415V	-
			400V	-
			380V	-
			230V	-
			200V	-
		DC	250V (*1)	40/20
Standard Attached parts		Front connection	Terminal screw: M10 bolt×65 (2-pole: 16pcs, 3-pole: 24pcs, 4-pole: 32pcs) Mounting screw: M8×40 (4pcs) Insulating barrier: (2P: 1pc, 3P: 2pcs, 4P: 3pcs) Auxiliary handle: (1pc)	
		Rear connection	Terminal screw: M10 bolt×50 (2-pole: 16pcs, 3-pole: 24pcs, 4-pole: 32pcs) Mounting screw: M8×40 (4pcs) Auxiliary handle: (1pc)	

Note \*1 The standard specifications for NF1600-SDW are 2-pole.  
For DC special voltage use, we also have 3-pole and 4-pole models.

### Operating Characteristics

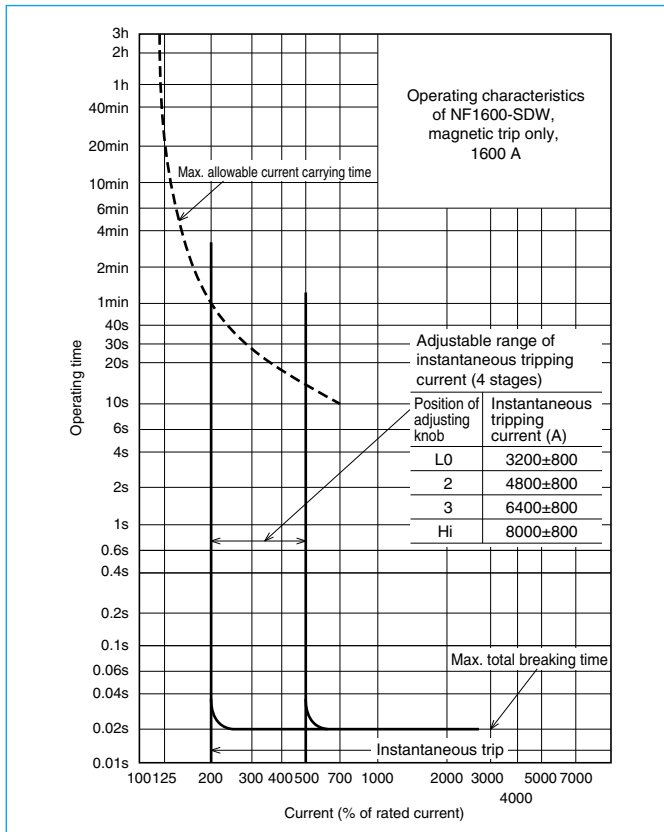

### Internal Accessories

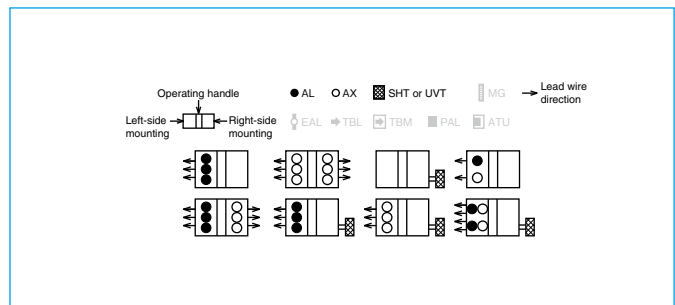

### External Accessories

(An order for ☆ should be placed at the same time as an order of circuit breaker main body.)

Accessories		Type name	Reference page	Accessories		Type name	Reference page
Operating handle	F	2, 3P F10SW	123	Auxiliary handle	HT	HT-10SW	135
		4P F10SW4P		Handle lock device	HL	HL (☆)	134
Mechanical interlock	MI	2, 3P MI-16SW3	136	Electrical operation device	NFM	2, 3P 4P (*1)	140
		4P MI-16SW4					

Note \*1 Specify the operation method and voltage. Order in combination with the breaker unit.

Outline Drawing

**Front connection**

Same dimensions as NF1600-SEW.

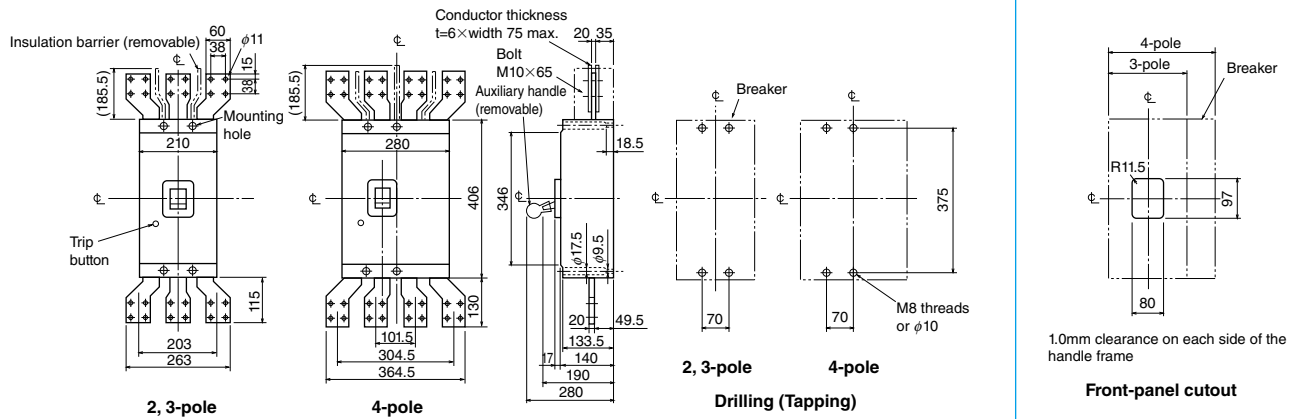

**Rear connection**

Differing in external dimensions from NF1600-SEW.

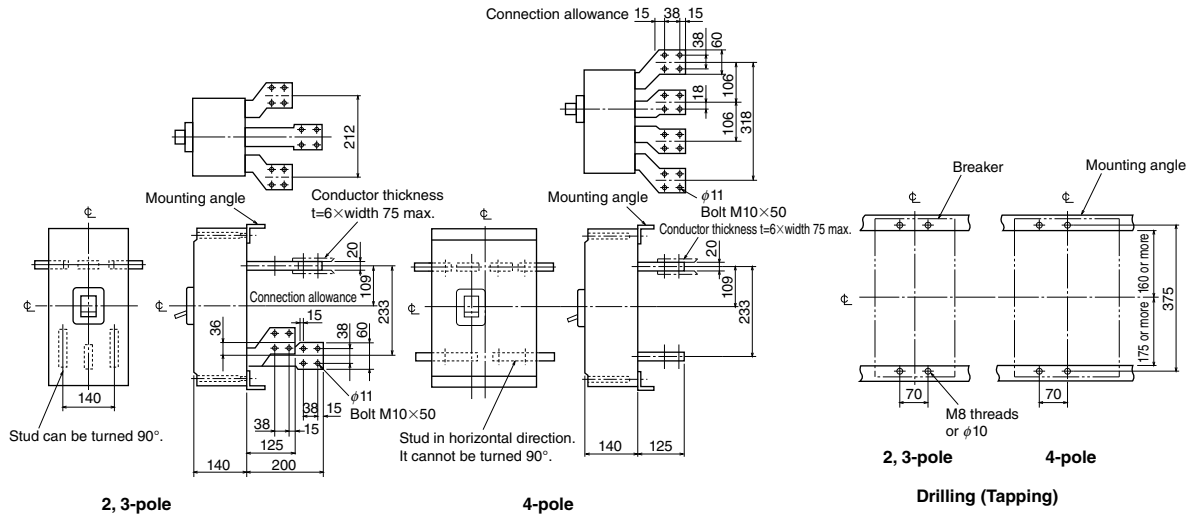

Remarks: 1. Standard specification of NF1600-SDW is 2-pole model. 3-pole and 4-pole models are available for DC special voltage.  
 2. 2-pole models are 3-pole models with the central pole removed.

**NV32-SV**  
**NV63-CV**  
**NV63-SV**  
**NV63-HV**



**NV63-SV**

Model		NV32-SV	NV63-CV	NV63-SV	NV63-HV			
Rated current I <sub>n</sub> (A)		(5) 6 10 (15) 16 20 25 (30) (32)	(5) (10) (15) 16 20 25 (30) 32 40 50 (60) 63	(5) (10) (15) 16 20 25 (30) 32 40 50 (60) 63	(15) 16 20 25 (30) 32 40 50 (60) 63			
Reference ambient temperature 40°C								
Number of poles		3	2	3	3			
Phase line		3φ3W, 1φ3W, 1φ2W	1φ2W	3φ3W, 1φ3W, 1φ2W	3φ3W, 1φ3W, 1φ2W			
Rated operational voltage U <sub>e</sub> (V)		AC 100-440	100-240	100-440	100-440			
High-speed type	Rated current sensitivity (mA)	30 100/200/500 selectable	30	30 100/200/500 selectable	30 100/200/500 selectable			
	Max operating time (s)	at ΔI <sub>n</sub>	0.1	0.1	0.1			
		at 5ΔI <sub>n</sub>	0.04	0.04	0.04			
Time-delay type	Rated current sensitivity (mA)	-	-	-	-			
	Max operating time (s)	-	-	-	-			
	Inertial operating time (s) (or more)	-	-	-	-			
Earth-leakage indication system			Mechanical type (button)	Mechanical type (button)	Mechanical type (button)			
Rated short-circuit breaking capacity (kA)	IEC 60947-2 EN 60947-2 (Icu/Ics)	AC	440V	5/5	-	2.5/2.5	7.5/7.5	10/8
			415V	5/5	-	2.5/2.5	7.5/7.5	10/8
			400V	5/5	-	5/5	7.5/7.5	10/8
			230V	10/10	7.5/7.5		15/15	25/19
			200V	10/10	7.5/7.5		15/15	25/19
			100V	10/10	7.5/7.5		15/15	25/19
Standard attached parts (Front connection)		Terminal screw: 50A or less M5×14 (2P: 4pcs, 3P: 6pcs) 60A or more M8×14 (2P: 4pcs, 3P: 6pcs) Mounting screw: M4×0.7×55 (2pcs) (*1) Insulation barrier: (2P: 1pc, 3P: 2pcs)						

Note \*1 Attached to NV63-SV and NV63-HV.

## Operating Characteristics

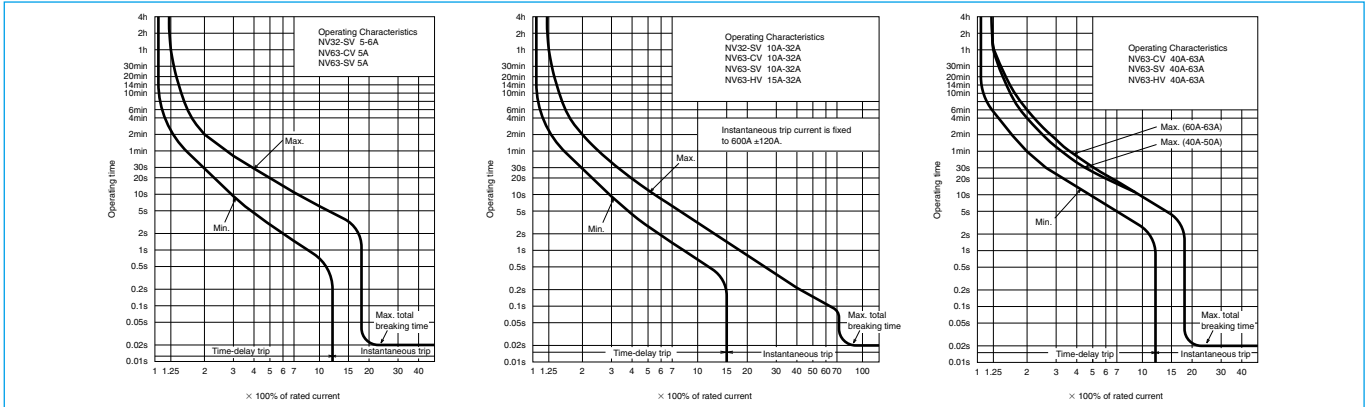

## Earth leakage Tripping Characteristics

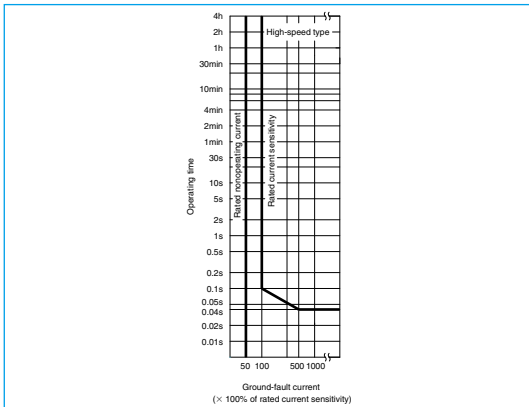

## Internal Accessories

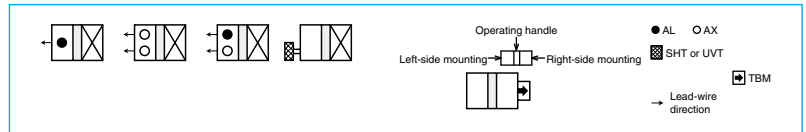

## Temperature Compensation Curve

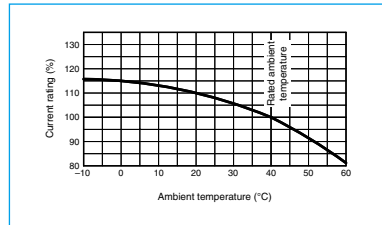

## Internal Wiring Diagram

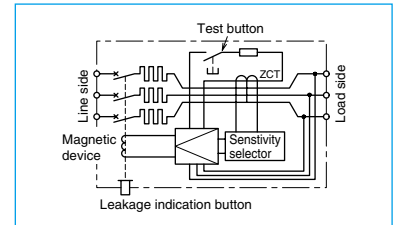

## External Accessories

Accessories		Type name	Reference page	Accessories		Type name	Reference page
Operating handle	F	F-05SV	123	Mechanical interlock	MI	MI-05SV3	136
	V	V-05SV	125		Small	TC-S	
Lock cover	LC	LC-05SV	134	Terminal cover	Large	TC-L	TCL-05SV3
	Handle lock device	HL (*1)			HLF-05SV	Skeleton	TTC
		HLN-05SV			Rear	BTC	BTC-05SV3
		HLS-05SV			Plug-in	PTC	PTC-05SV3
					IEC 35mm rail mounting adapters		DIN-05SV

Note \*1 HLF types are used for OFF lock and HLN types for ON lock.

Outline Drawing

**Front connection**

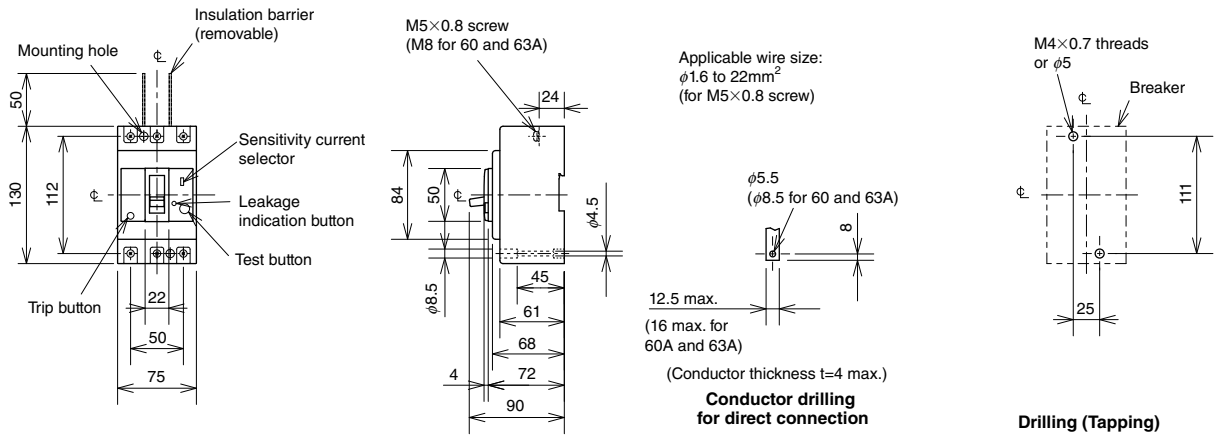

**Rear connection**

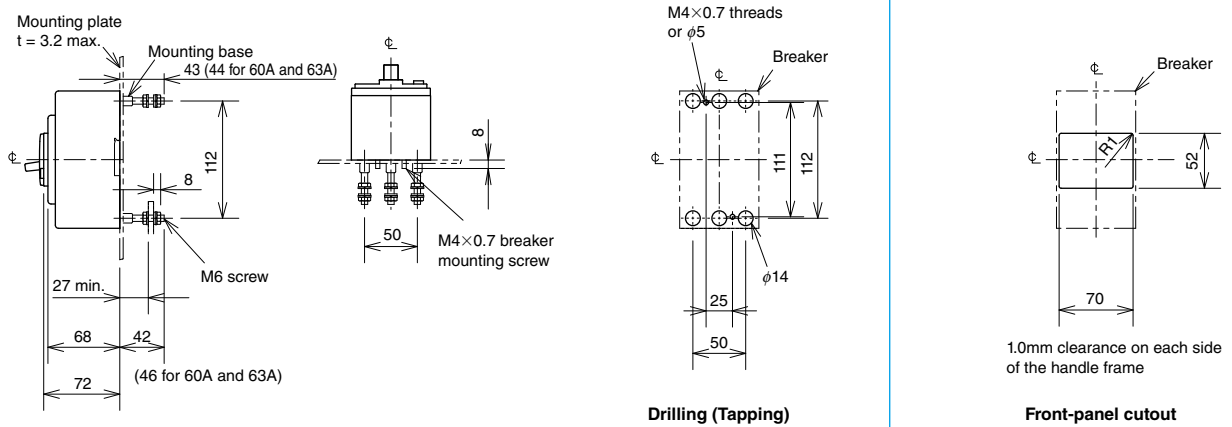

**Plug-in**

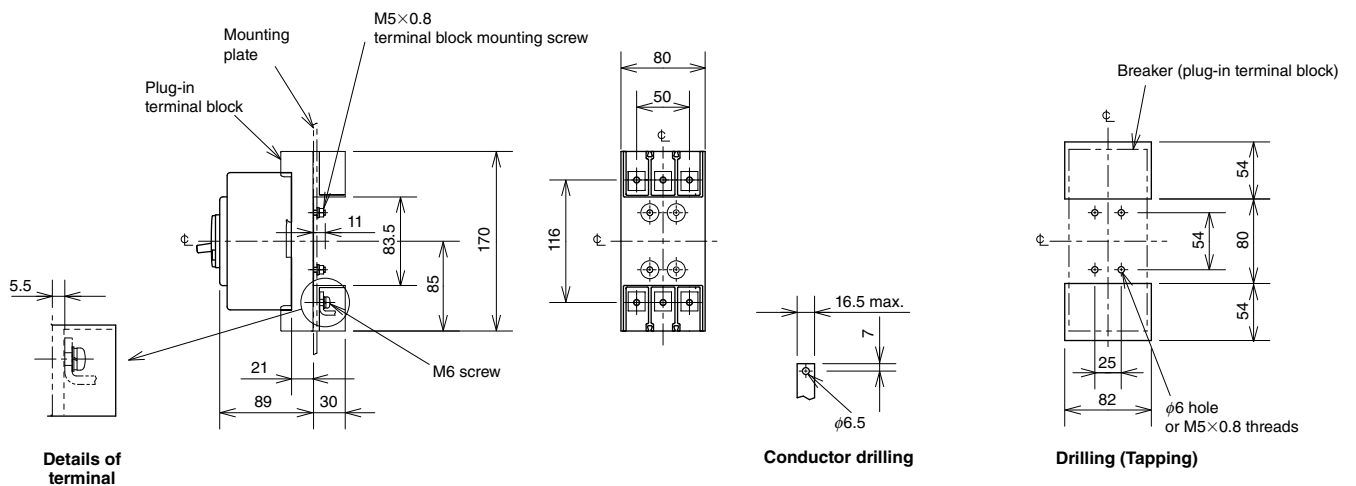

Remark: 1. 2-pole models are 3-pole models with the central pole removed.

## NV125-CV NV125-SV NV125-HV



NV125-SV

Model		NV125-CV		NV125-SV		NV125-HV	
Rated current In (A) Reference ambient temperature 40°C		(60) 63 (75) 80 100 125		(15) 16 20 30 32 40 50 (60) 63 (75) 80 100 125 (*2)		(15) 16 20 (30) 32 40 50 (60) 63 75 80 100 125 (*2)	
Number of poles		3		3		4	
Phase line		3φ3W, 1φ3W, 1φ2W		3φ3W, 1φ3W, 1φ2W		3φ4W, 3φ3W, 1φ3W, 1φ2W	
Rated operational voltage Ue (V) (*3)		AC 100-440		100-440		200-440	
High-speed type	Rated current sensitivity (mA)	30 100/200/500 selectable		30 100/200/500 selectable		30 100/200/500 selectable	
	Max operating time (s)	at Δn		0.1		0.1	
		at 5IΔn		0.04		0.04	
Time-delay type	Rated current sensitivity (mA)	(100/200/500 selectable)		(100/200/500 selectable)		(100/200/500 selectable)	
	Max operating time (s)	(0.45/1.0/2.0 selectable)		(0.45/1.0/2.0 selectable)		(0.45/1.0/2.0 selectable)	
	Inertial operating time (s) (or more)	(0.1/0.5/1.0)		(0.1/0.5/1.0)		(0.1/0.5/1.0)	
Earth-leakage indication system		Mechanical type (button)		Mechanical type (button)		Mechanical type (button)	
Rated short-circuit breaking capacity (kA)	IEC 60947-2 EN 60947-2 (Icu/Ics)	AC	440V	10/5	25/25	50/38	
			415V	10/5	30/30	50/38	
			400V	10/5	30/30	50/38	
			230V	30/15	50/50	100/75	
			200V	30/15	50/50	100/75	
			100V	30/15	50/50	100/75	-
Standard attached parts (Front connection)		Terminal screw: M8x14 (3P: 6pcs, 4P: 8pcs) Mounting screw: M4x0.7x55 (3P: 2pcs, 4P: 4pcs) (*1) Insulation barrier: (3P: 2pcs, 4P: 3pcs)					

Note \*1 Attached to NV125-SV and NV125-HV.  
\*2 In case of time delay type, rated current is produced with 20amp. or more.  
\*3 Rated operational voltage of time-delay type is for 200-440V.

## Operating Characteristics

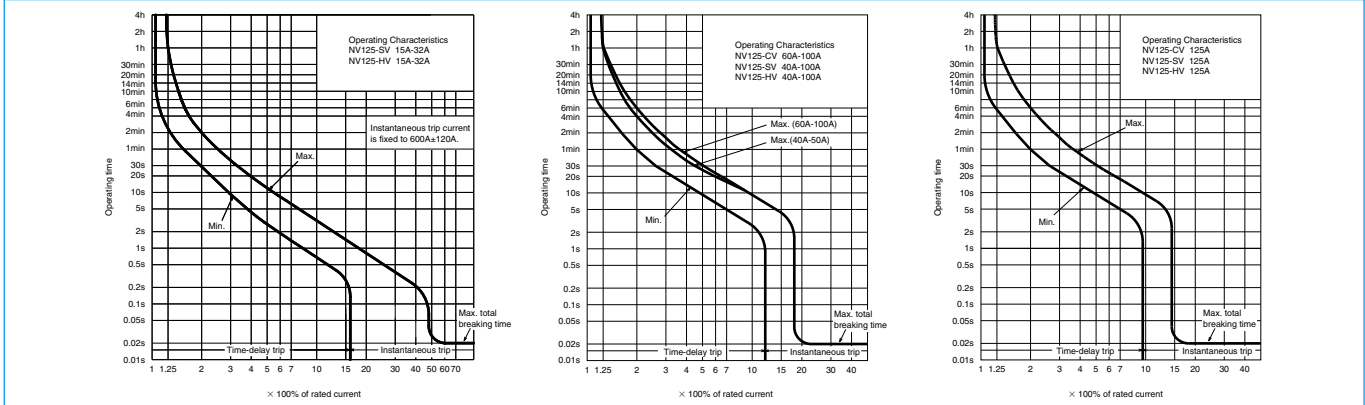

## Earth leakage Tripping Characteristics

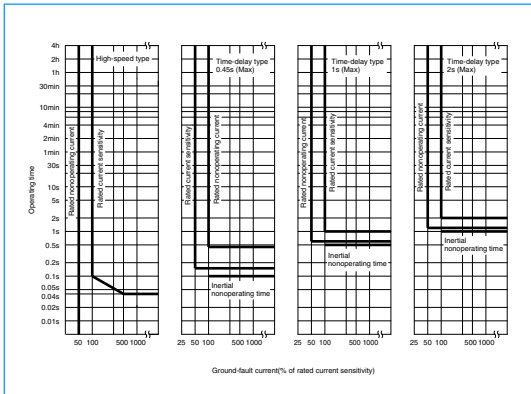

## Internal Accessories

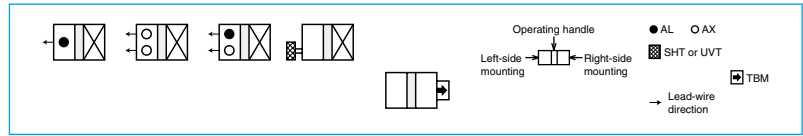

## Temperature Compensation Curve

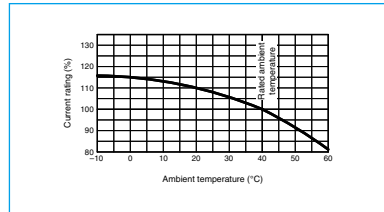

## Internal Wiring Diagram

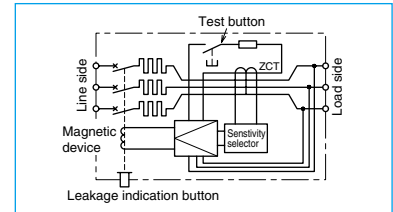

## External Accessories

Accessories		Type name	Reference page	Accessories		Type name	Reference page
Operating handle	F	F-1SV	123	Mechanical interlock	MI	3P MI-05SV3	136
	V	V-1SV	125			4P MI-1SV4	
Lock cover	LC	LC-05SV	134	Terminal cover	Small	3P TCS-1SV3	128
Handle lock device	HL (*1)	HLF-05SV				4P TCS-1SV4	
		HLN-05SV			3P TCL-1SV3		
		HLS-05SV			4P TCL-1SV4		
			3P TTC-1SV3				
			4P TTC-1SV4				
			3P BTC-1SV3				
			4P BTC-1SV4				
			3P PTC-1SV3				
			4P PTC-1SV4				
				Electrical operation device	(*2)		140

Notes \*1 HLF types are used for OFF lock and HLN types for ON lock.  
\*2 Specify the working voltage. Refer to the reference page for type name.

Outline Drawing

Front connection

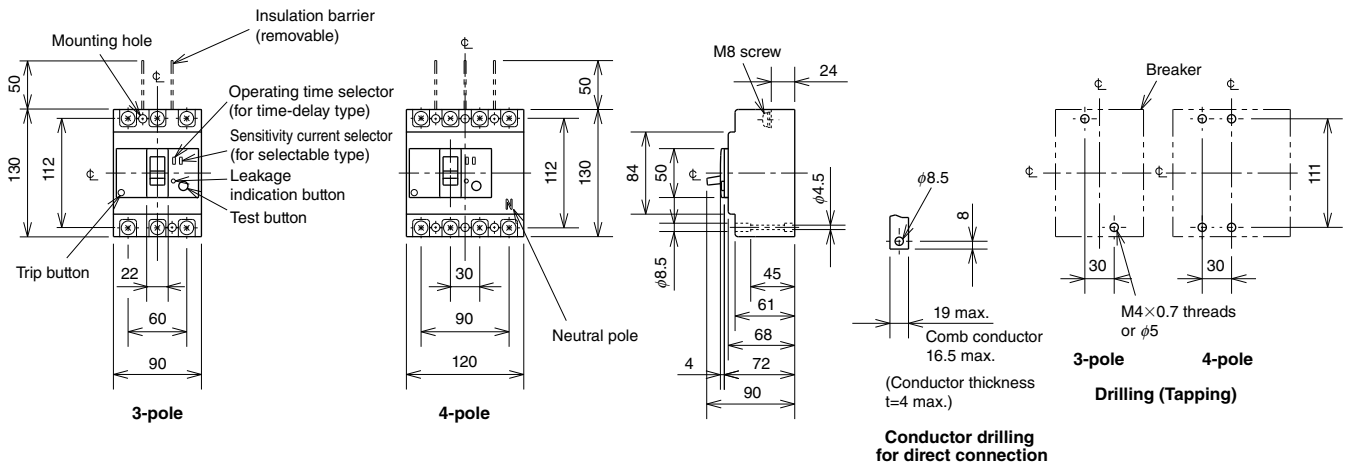

Rear connection

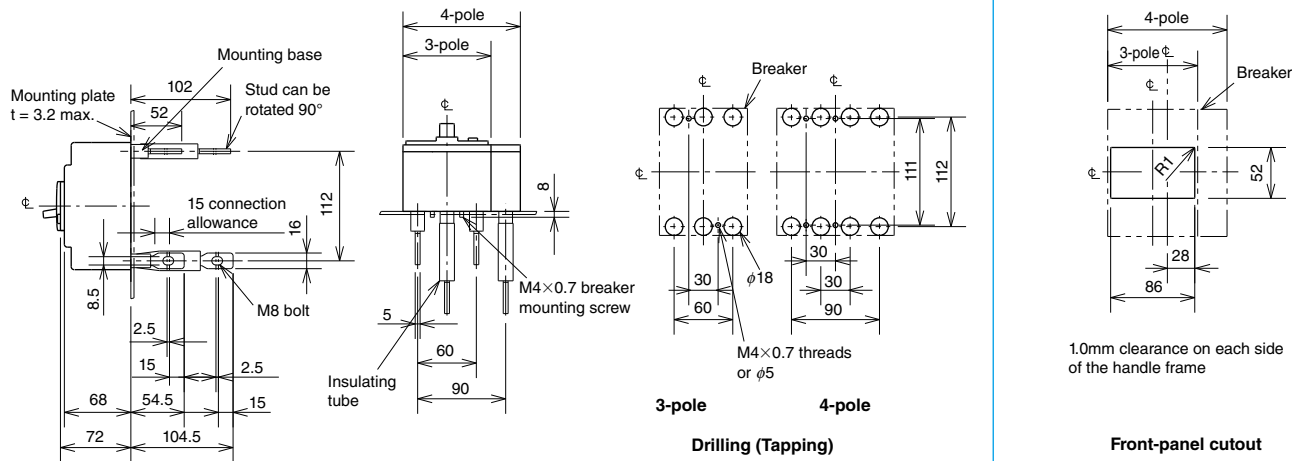

Plug-in

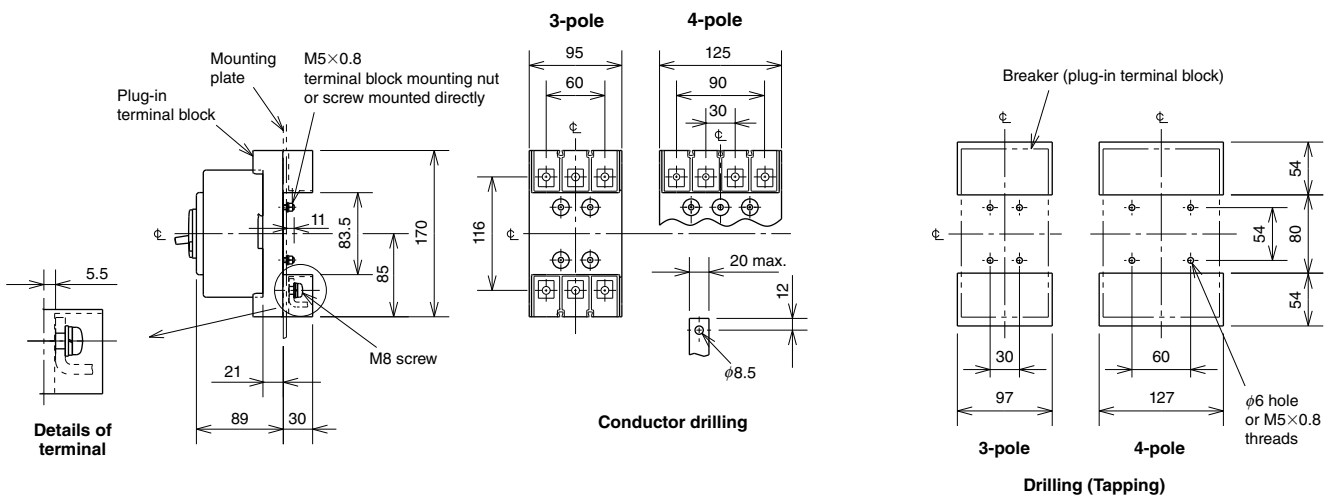

Remark: 1. Only 3-pole models are available for NV125-CV.

## NV250-CV NV250-SV NV250-HV



NV250-CV

Model		NV250-CV	NV250-SV	NV250-HV		
Rated current In (A) Reference ambient temperature 40°C		125 150 175 200 225 250	125 150 175 200 225 250	125 150 175 200 225 250		
Number of poles		3	3 4	3 4		
Phase line		3φ3W, 1φ3W, 1φ2W	3φ3W, 1φ3W, 1φ2W	3φ3W, 1φ3W, 1φ2W 3φ4W		
Rated operational voltage Ue (V) (*1)		AC 100-440	100-440 200-440	100-440 200-440		
High-speed type	Rated current sensitivity (mA)	30 100/200/500 selectable	(30) 100/200/500 selectable	30 100/200/500 selectable		
	Max operating time (s)	at ΔIn	0.1	0.1		
		at 5ΔIn	0.04	0.04		
Time-delay type	Rated current sensitivity (mA)	(100/200/500 selectable)	(100/200/500 selectable)	(100/200/500 selectable)		
	Max operating time (s)	(0.45/1.0/2.0 selectable)	(0.45/1.0/2.0 selectable)	(0.45/1.0/2.0 selectable)		
	Inertial operating time (s) (or more)	(0.1/0.5/1.0)	(0.1/0.5/1.0)	(0.1/0.5/1.0)		
Earth-leakage indication system		Mechanical type (button)	Mechanical type (button)	Mechanical type (button)		
Rated short-circuit breaking capacity (kA)	IEC 60947-2 EN 60947-2 (Icu/Ics)	AC	440V	15/12	36/36	65/65
			415V	25/19	36/36	70/70
			400V	25/19	36/36	75/75
			230V	36/27	85/85	100/100
			200V	36/27	85/85	100/100
			100V	36/27	85/85	100/100
Standard attached parts (Front connection)		Terminal screw: M8 (Bolt(Hex-socket))×16 (3P: 6pcs, 4P: 8pcs) Mounting screw: M4×0.7×55 (3P: 2pcs, 4P: 4pcs) Insulation barrier: (3P: 4pcs, 4P: 6pcs)				

Note \*1 Rated operational voltage of time-delay type is for 200-440V.

### Operating Characteristics

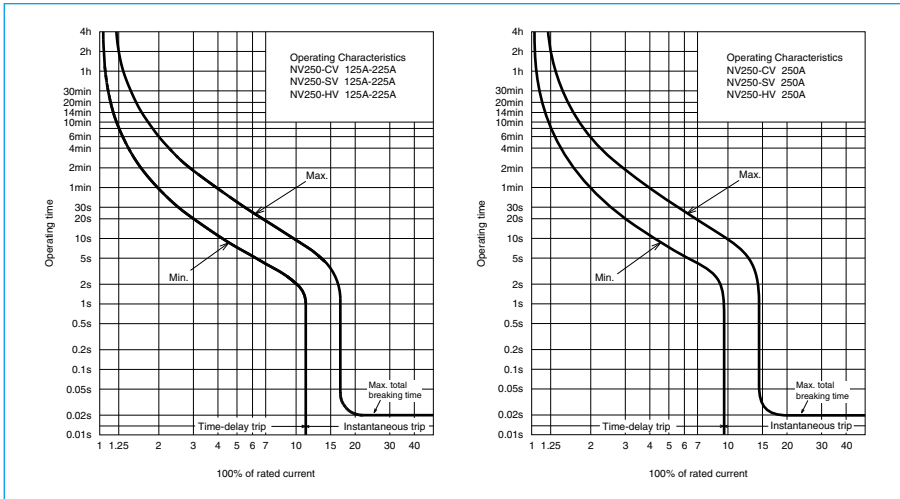

### Earth leakage Tripping Characteristics

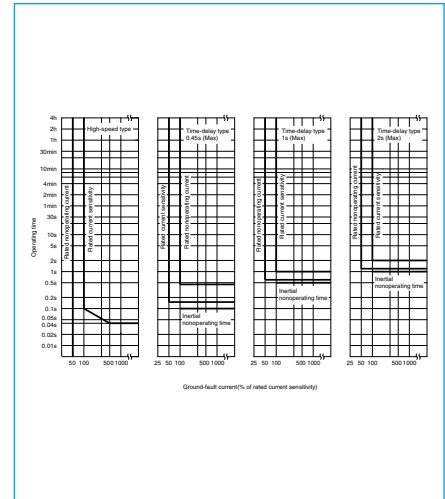

### Internal Accessories

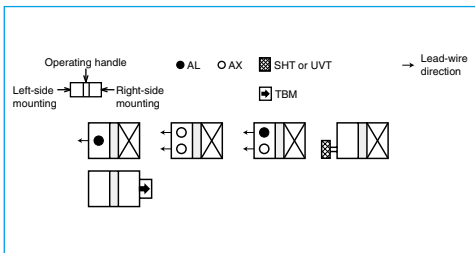

### Temperature Compensation Curve

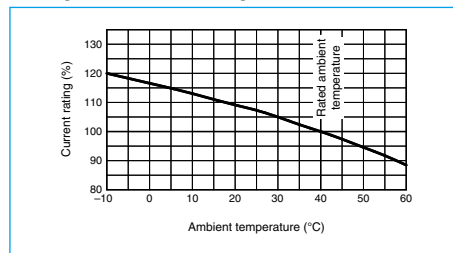

### Internal Wiring Diagram

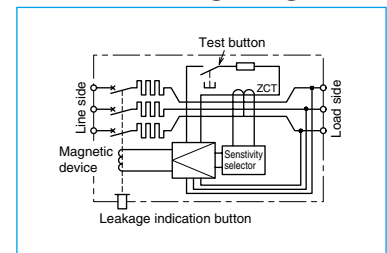

### External Accessories

Accessories	Type name	Reference page	Accessories	Type name	Reference page	
Operating handle	F	F-2SV	Mechanical interlock	3P	MI-05SV3	
	V	V-2SV		4P	MI-2SV4	
Lock cover	LC	LC-05SV	Terminal cover	3P	TCS-2SV3	
Handle lock device	HL (*1)	HLF-05SV		4P	TCS-2SV4	
		HLN-05SV		3P	TCL-2SV3	
	HL-S	HLS-2SV		4P	TCL-2SV3L	
				Small	3P	TTC-2SV3
					4P	TTC-2SV4
				Large	3P	TTC-2SV3L
					4P	TTC-2SV4
Skeleton	TTC			3P	TTC-2SV3	
				4P	TTC-2SV4	
Rear	BTC		3P	BTC-2SV3		
			4P	BTC-2SV4		
Plug-in	PTC		3P	PTC-2SV3		
			4P	PTC-2SV4		
Electrical operation device			(*2)		140	

Notes \*1 HLF types are used for OFF lock and HLN types for ON lock.  
\*2 Specify the working voltage. Refer to the reference page for type name.

Outline Drawing

**Front connection**

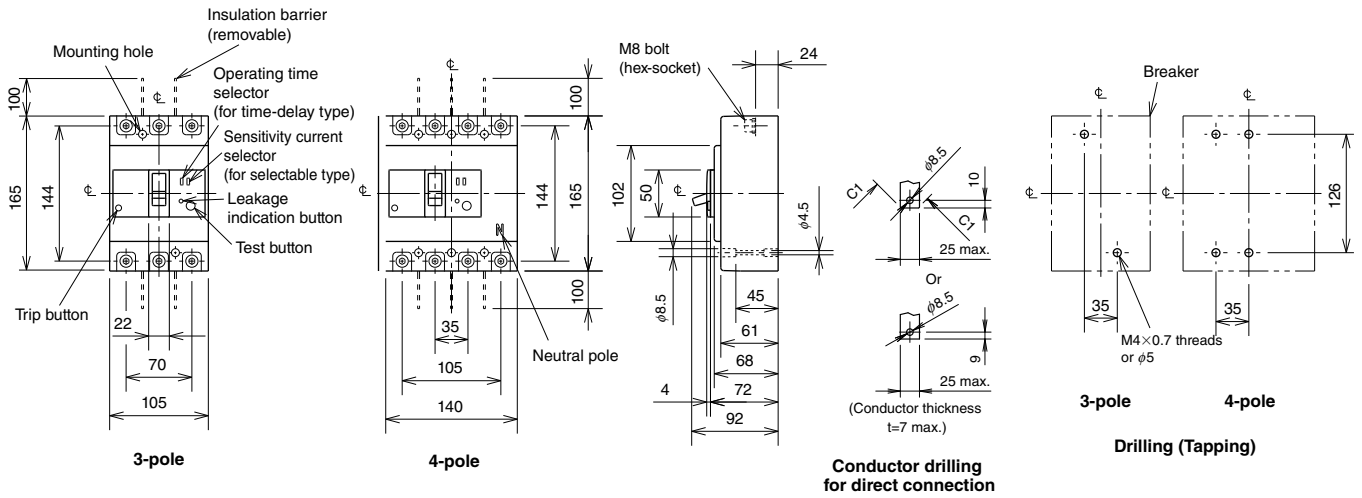

**Rear connection**

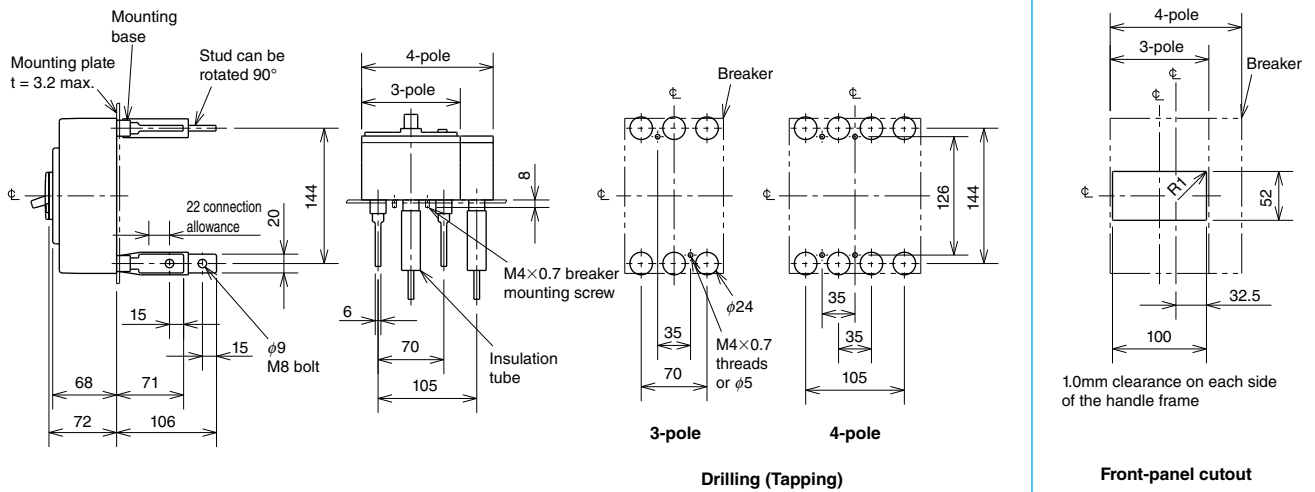

**Plug-in**

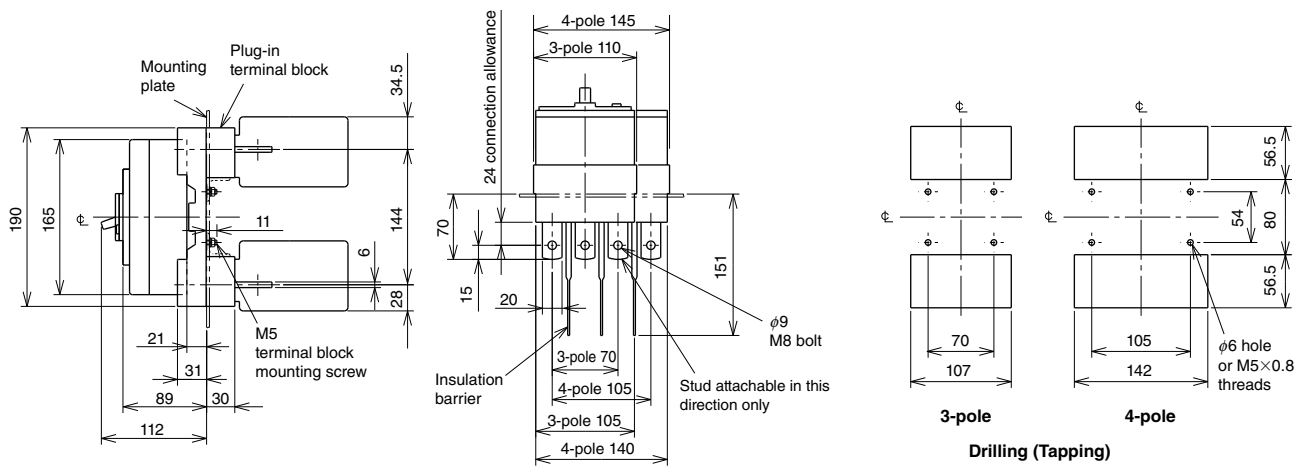

Remark: 1. Only 3-pole models are available for the model of NV250-CV.

## NV125-SEV NV125-HEV NV250-SEV NV250-HEV



NV250-SEV

Model		NV125-SEV	NV125-HEV	NV250-SEV	NV250-HEV		
Rated current In (A) Reference ambient temperature 40°C		125	125	250	250		
Current setting Ir (A)		Adjustable 63-125 (6.25A step)		Adjustable 125-250 (12.5A step)	Adjustable 125-250 (12.5A step)		
Number of poles		3 4	3 4	3	3		
Phase line		3φ3W, 1φ3W, 1φ2W	3φ4W	3φ3W, 1φ3W, 1φ2W	3φ3W, 1φ3W, 1φ2W		
Rated operational voltage Ue (V) (*1)		AC 100-440		100-440	100-440		
High-speed type	Rated current sensitivity (mA)	(30) 100/200/500 selectable		(30) 100/200/500 selectable	(30) 100/200/500 selectable		
	Max operating time (s)	at ΔIn 0.1 at 5ΔIn 0.04		0.1 0.04	0.1 0.04		
Time-delay type	Rated current sensitivity (mA)	(100/200/500 selectable)		(100/200/500 selectable)	(100/200/500 selectable)		
	Max operating time (s)	(0.45/1.0/2.0 selectable)		(0.45/1.0/2.0 selectable)	(0.45/1.0/2.0 selectable)		
Inertial operating time (s) (or more)		(0.1/0.5/1.0)		(0.1/0.5/1.0)	(0.1/0.5/1.0)		
Earth-leakage indication system		Mechanical type (button)		Mechanical type (button)	Mechanical type (button)		
Rated short-circuit breaking capacity (kA)	IEC 60947-2 EN 60947-2 (Icu/Ics)	AC	440V	36/36	65/65	36/36	65/65
			415V	36/36	70/70	36/36	70/70
			400V	36/36	75/75	36/36	75/75
			230V	85/85	100/100	85/85	100/100
			200V	85/85	100/100	85/85	100/100
			100V	85/85	100/100	85/85	100/100
Standard attached parts (Front connection)		Terminal screw: M8 (Bolt(Hex-socket))×16 (3P: 6pcs, 4P: 8pcs) Mounting screw: M4×0.7×55 (3P: 2pcs, 4P: 4pcs) Insulation barrier: (3P: 4pcs, 4P: 6pcs)					

Note \*1 Rated operational voltage of time-delay type is for 200-440V.

### Operating Characteristics

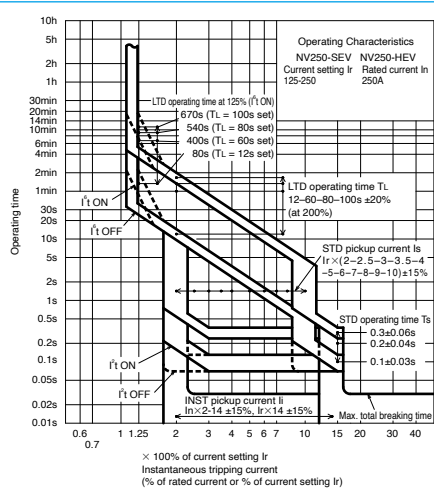
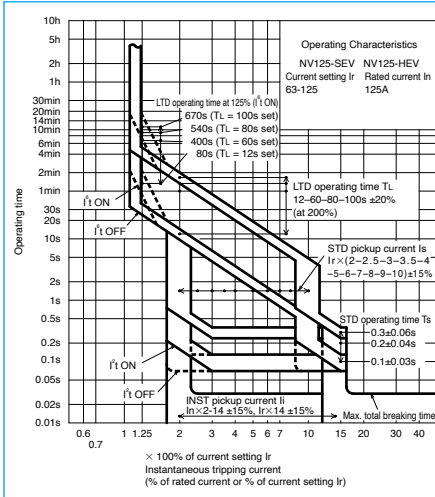

### Earth leakage Tripping Characteristics

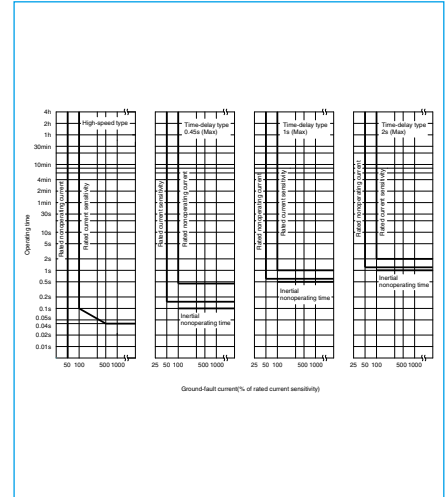

### Internal Accessories

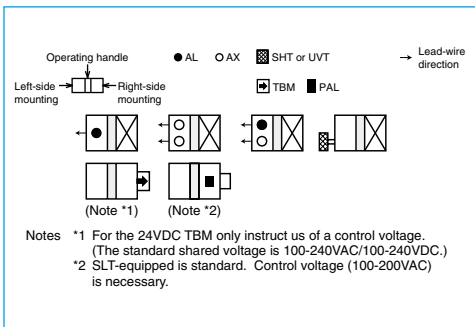

### Current Reducing Curve

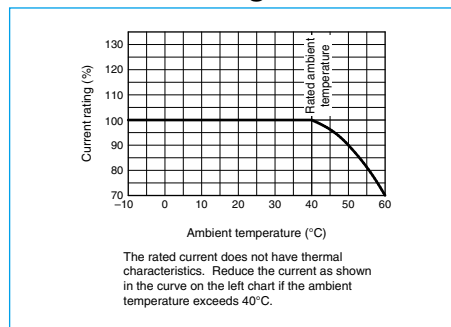

### Internal Wiring Diagram

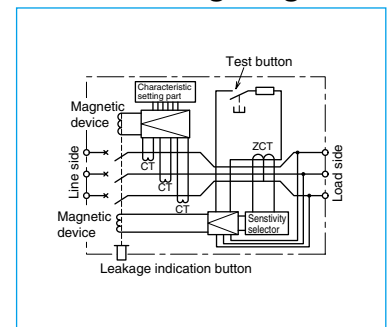

### External Accessories

Accessories	Type name	Reference page	Accessories	Type name	Reference page			
Operating handle	F V	F-2SV V-2SV	123	Mechanical interlock	MI	3P MI-05SV3 4P MI-2SV4	136	
Lock cover	LC	LC-05SV	125	Terminal cover (*3)	Small	TC-S	3P TCS-2SV3 4P TCS-2SV4	128
Handle lock device	HL (*1)	HLF-05SV HLN-05SV	134		Large	TC-L	3P TCL-2SV3 4P TCL-2SV3L	
	HL-S	HLS-2SV					3P TTC-2SV3 4P TTC-2SV4	
					Skeleton	TTC	3P TTC-2SV3 4P TTC-2SV4	
					Rear	BTC	3P BTC-2SV3 4P BTC-2SV4	
					Plug-in	PTC	3P PTC-2SV3 4P PTC-2SV4	
				Electrical operation device		(*2)	140	

Notes  
\*1 HLF types are used for OFF lock and HLN types for ON lock.  
\*2 Specify the working voltage. Refer to the reference page for type name.  
\*3 For NV125-HEV and NV250-HEV with PAL, specify the model name with MP at the end.

Outline Drawing

Front connection

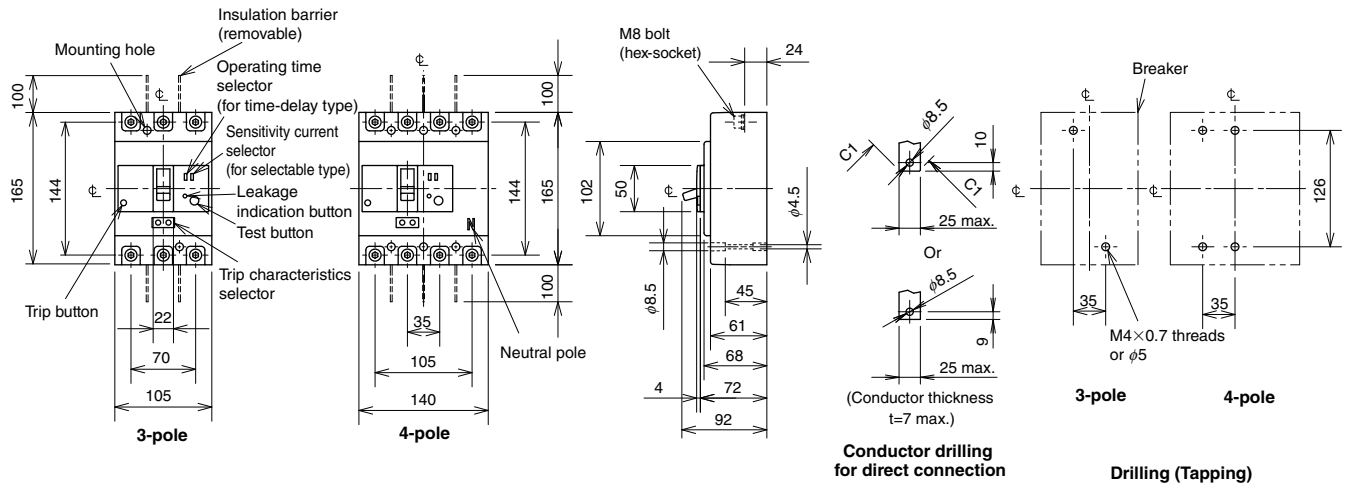

Rear connection

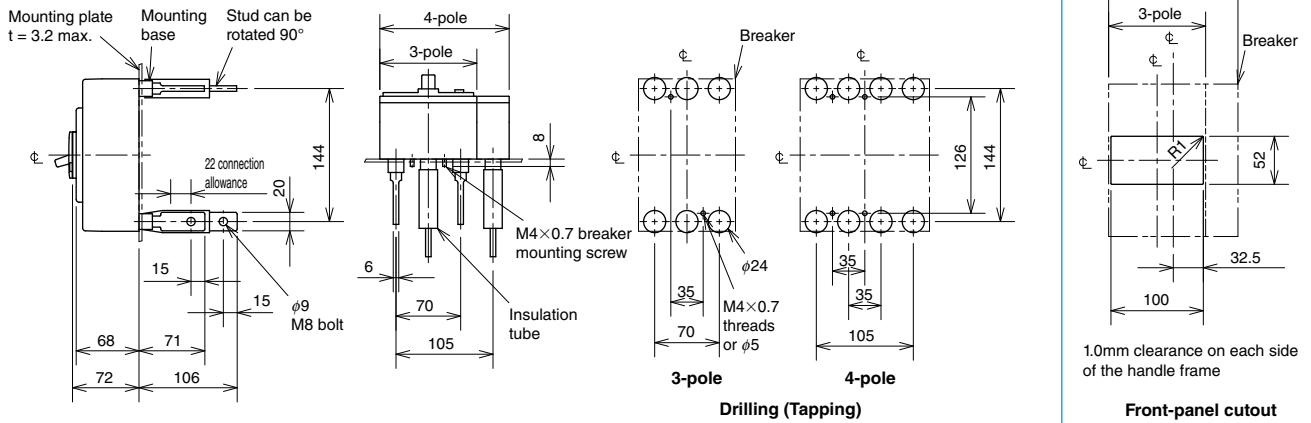

Plug-in

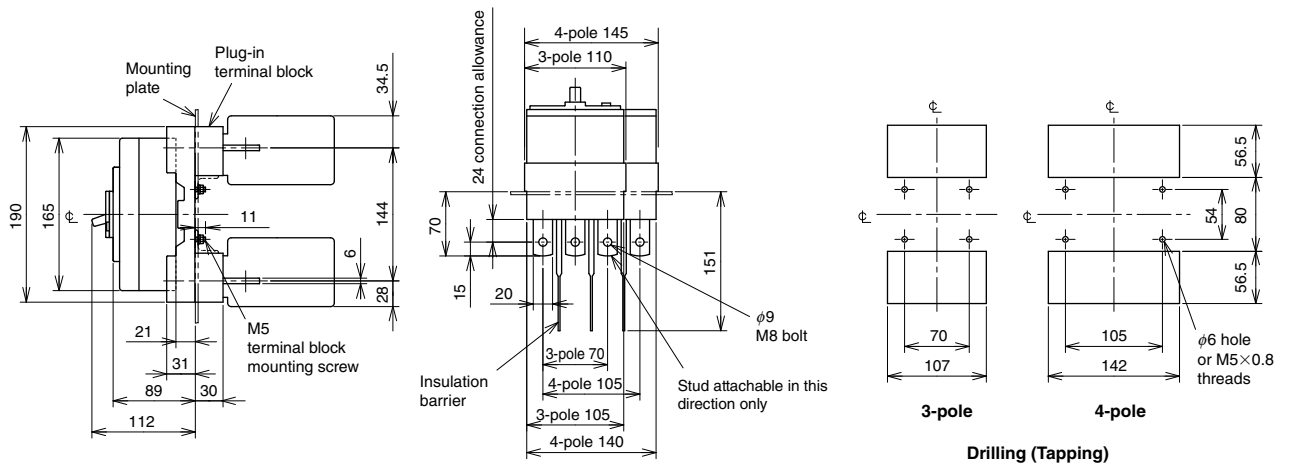

Remark: 1. Only 3-pole models are available for the model of NV250-SEV and NV250-HEV.

## NV400-CW NV400-SW



NV400-SW

Model		NV400-CW	NV400-SW
Rated current In (A) Reference ambient temperature 40°C		250 300 350 400	
Number of poles		3	
Phase line		3φ3W, 1φ3W, 1φ2W	
Rated operational voltage Ue (V) (*1)		AC 100-440	
High-speed type	Rated current sensitivity (mA)	(30) 100 · 200 · 500 Selectable	
	Max operating time (s)	at IΔn 0.1 at 5IΔn 0.04	
Time-delay type	Rated current sensitivity (mA)	(100 · 200 · 500 Selectable)	
	Max operating time (s)	(0.45 · 1.0 · 2.0 Selectable)	
Inertial operating time (s) (or more)		(0.1 · 0.5 · 1.0)	
Earth leakage protection characteristic		Type AC	
Earth-leakage indication system		Mechanical type (Button)	
Rated short-circuit breaking capacity (kA) IEC 60947-2 (Icu/Ics) EN 60947-2	AC	440V	25/13 42/42
		415V	36/18 45/45
		400V	36/18 45/45
		230V	50/25 85/85
		200V	50/25 85/85
		100V	50/25 85/85
Standard attached parts (Front connection)		Terminal screw: M12 bolt×35 (3-pole: 6pcs) Mounting screw: M6×60 (4pcs) Insulation barrier: (4pcs)	

Note \*1 Rated operational voltage of time-delay type is for 200-440V.

### Operating Characteristics

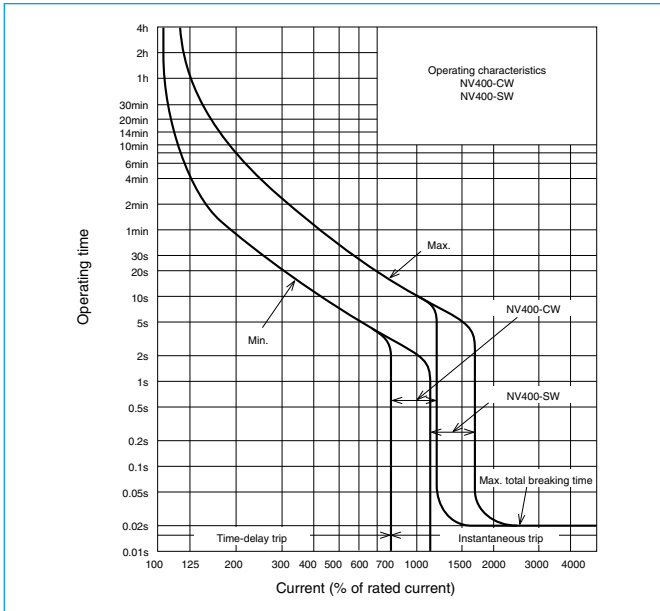

### Earth Leakage Tripping Characteristics

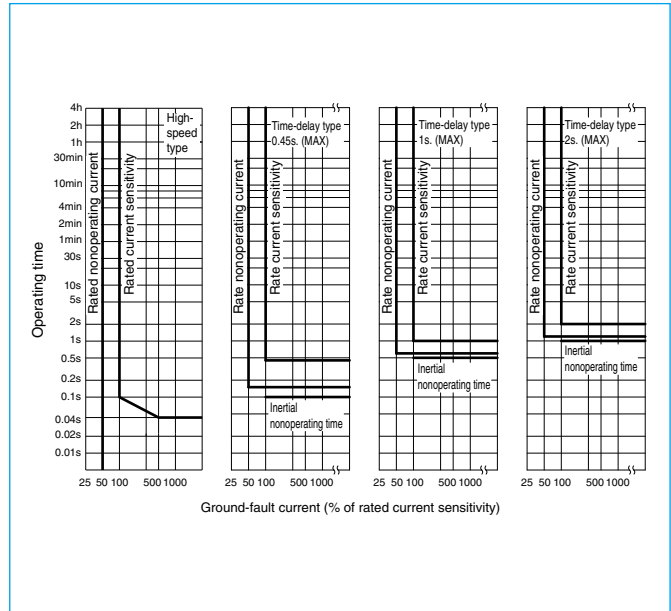

### Internal Accessories

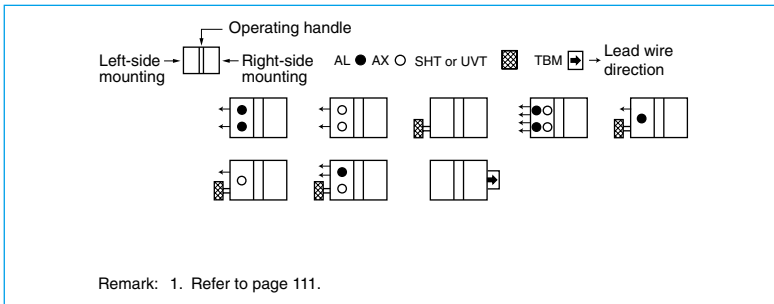

### Temperature Compensation Curve

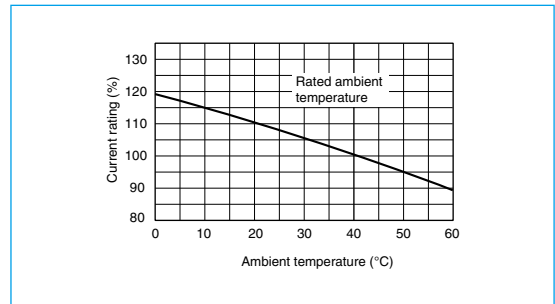

### External Accessories

Accessories	Type name	Reference page	Accessories	Type name	Reference page
Operating handle	F	F-4S	Auxiliary handle	HT	HT-4CW, HT-4SW
	V	V-4S			135
Mechanical interlock	MI	MI-4SW3	Terminal cover	Large	TC-L
				Skeleton	TTC
				Rear	BTC
			Handle lock device	HL	HL-4CW, HL-4SW
				HL-S	HLS-4SW
			Electrical operation device	(*1)	140

Note \*1 Specify the operation method and voltage. Order in combination with the breaker unit.

### Internal Wiring Diagram

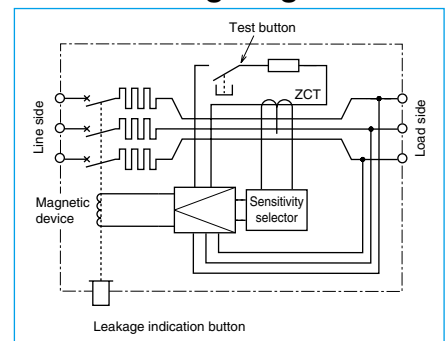

Outline Drawing

Front connection

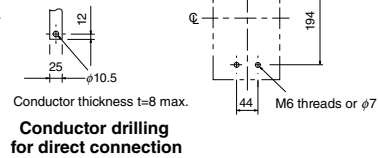
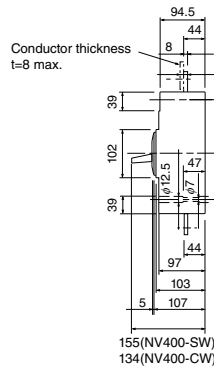
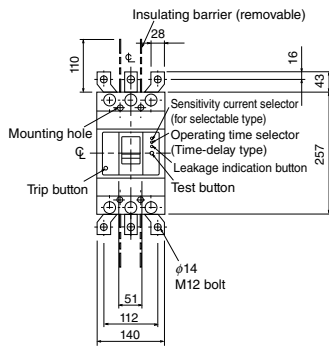

Drilling (Tapping)

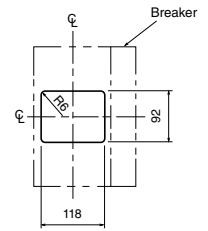

1.0mm clearance on each side of the handle frame.

Front-panel cutout

Rear connection

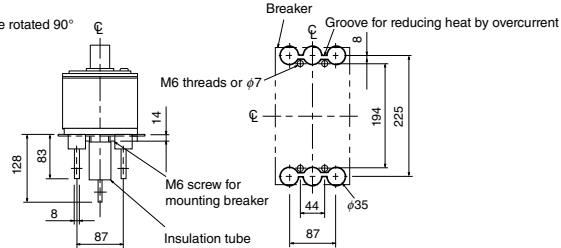
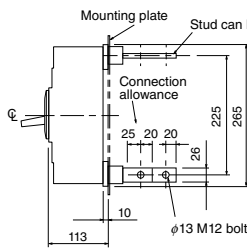

Drilling (Tapping)

Boring dimensions for rear connection type barriers (3-pole)

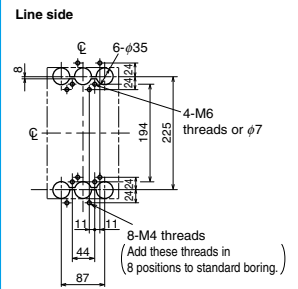

Load side

Note The bore dimensional drawing shows the breaker viewed from the rear.

Plug-in

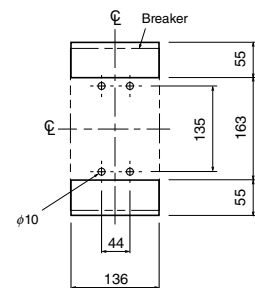
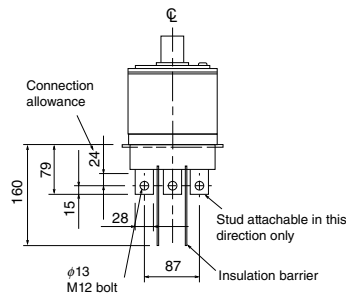
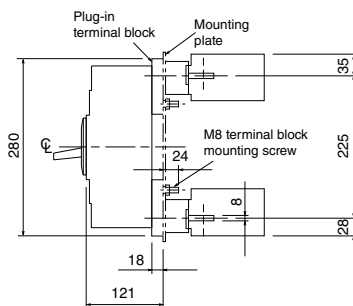

Drilling (Tapping)

## NV400-SEW NV400-HEW



NV400-SEW

Model		NV400-SEW		NV400-HEW	
Rated current I <sub>n</sub> (A)		Adjustable			
Reference ambient temperature 40°C		200 225 250 300 350 400			
Number of poles		3	4	3	4
Phase line		3P : 3φ3W, 1φ3W, 1φ2W 4P : 3φ4W			
Rated operational voltage U <sub>e</sub> (V) (*1)		AC 100-440			
High-speed type	Rated current sensitivity (mA)	(30) 100 · 200 · 500 Selectable			
	Max operating time (s)	at IΔn 0.1			
		at 5IΔn 0.04			
Time-delay type	Rated current sensitivity (mA)	(100 · 200 · 500 Selectable)			
	Max operating time (s)	(0.45 · 1.0 · 2.0 Selectable)			
	Inertial operating time (s) (or more)	(0.1 · 0.5 · 1.0)			
Earth leakage protection characteristic		Type AC			
Earth-leakage indication system		Mechanical type (Button)			
Rated short-circuit breaking capacity (kA) IEC 60947-2 (I <sub>cu</sub> /I <sub>cs</sub> ) EN 60947-2	AC	440V	42/42	65/65	
		415V	50/50	70/70	
		400V	50/50	70/70	
		230V	85/85	100/100	
		200V	85/85	100/100	
		100V	85/85	100/100	
Standard attached parts (Front connection)		Terminal screw: M12 boltx35 (3-pole: 6pcs, 4-pole: 8pcs) Mounting screw: M6x72 (4pcs) Insulation barrier: (3P: 4pcs, 4P: 6pcs)			

Note \*1 Rated operational voltage of time-delay type is for 200-440V.

### Operating Characteristics

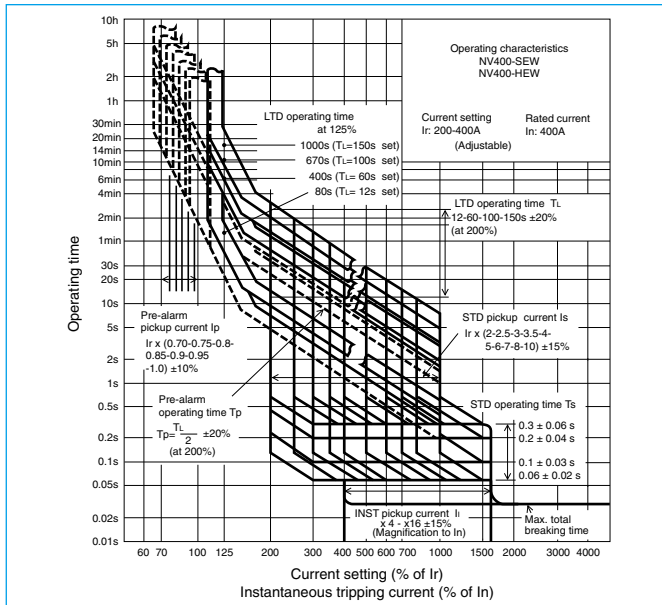

### Earth Leakage Tripping Characteristics

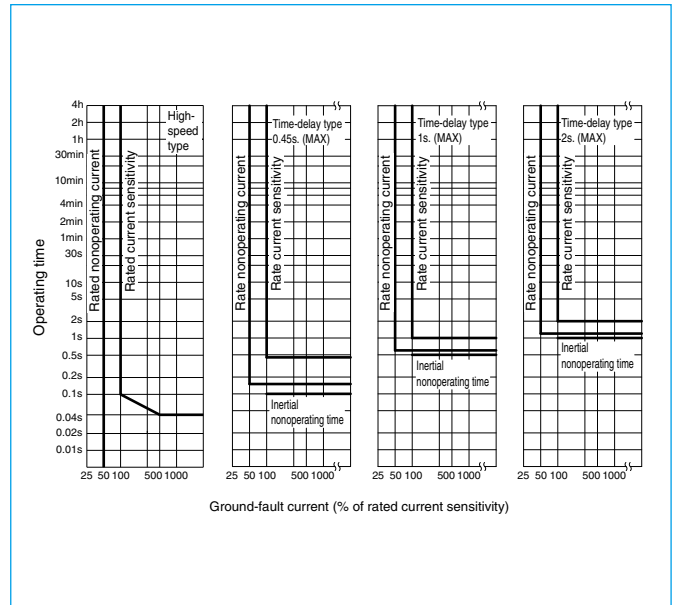

### Internal Accessories

Operating handle

Left-side mounting

Right-side mounting

● AL ○ AX ■ SHT or UVT □ TBM → Lead wire direction

■ PAL

Remarks: 1. Instead of TBM, pre-alarm module (PAL) can be attached.  
2. Refer to page 111.

### Current Reducing Curve

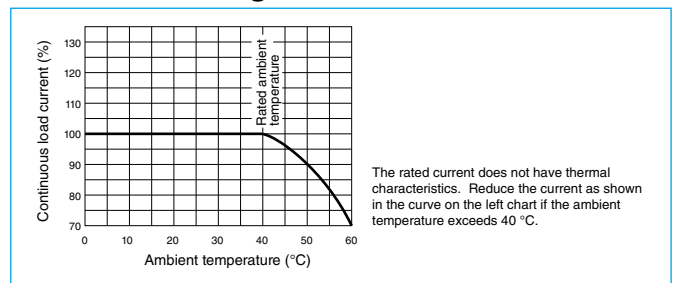

### External Accessories

Accessories		Type name	Reference page	Accessories		Type name	Reference page	
Operating handle	F	F-4S	123	Auxiliary handle	HT	HT-4SW	135	
	V	V-4S	125	Terminal cover	Large	TC-L	3P TCL-4SW3 (*1) 4P TCL-4SW4 (*1)	128
Mechanical interlock	MI	3P MI-4SW3 4P MI-4SW4	136		Skeleton	TTC	3P TTC-4SW3 4P TTC-4SW4	
	Handle lock device				Rear	BTC	3P BTC-4SW3 (*2) 4P BTC-4SW4	
					HL	HL-4SW	134	
			HL-S		HLS-4SW			
Electrical operation device	NVM	3P 4P	(*3)		140			

Notes \*1 This is for NV400-SEW.  
\*2 This is for NV400-SEW. For rear terminal cover of NV400-HEW, use PTC-4SW3.  
\*3 Specify the operation method and voltage. Order in combination with the breaker unit.

### Internal Wiring Diagram

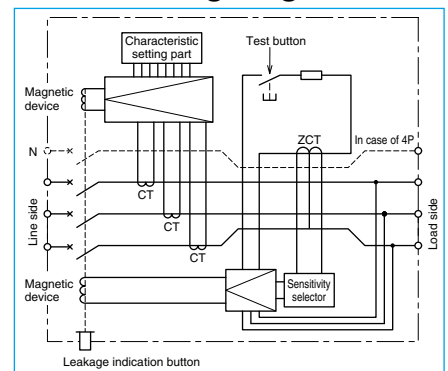

Outline Drawing

Front connection

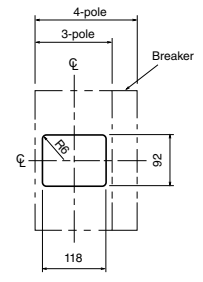
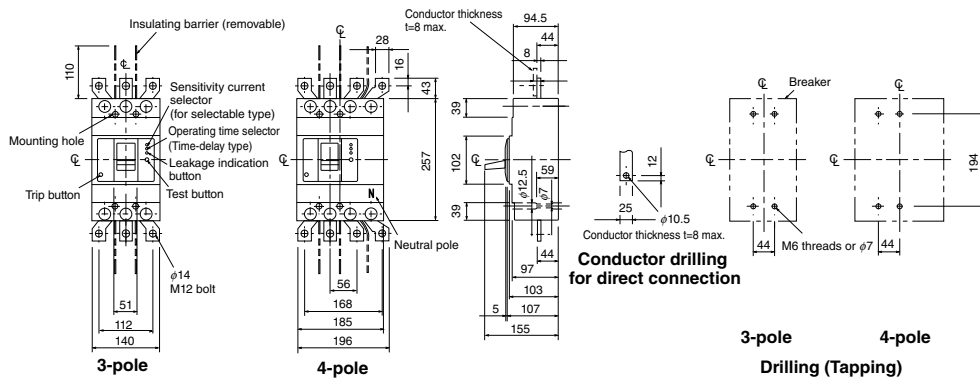

Front-panel cutout

Rear connection

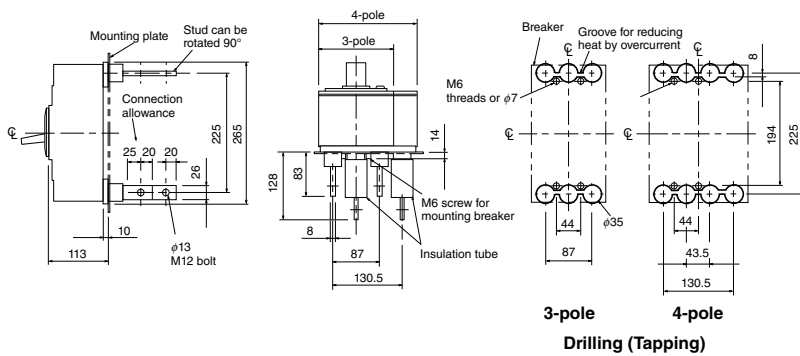

Boring dimensions for rear connection type barriers (3-pole)

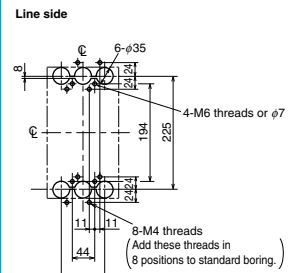

Load side

Note The bore dimensional drawing shows the breaker viewed from the rear.

Plug-in

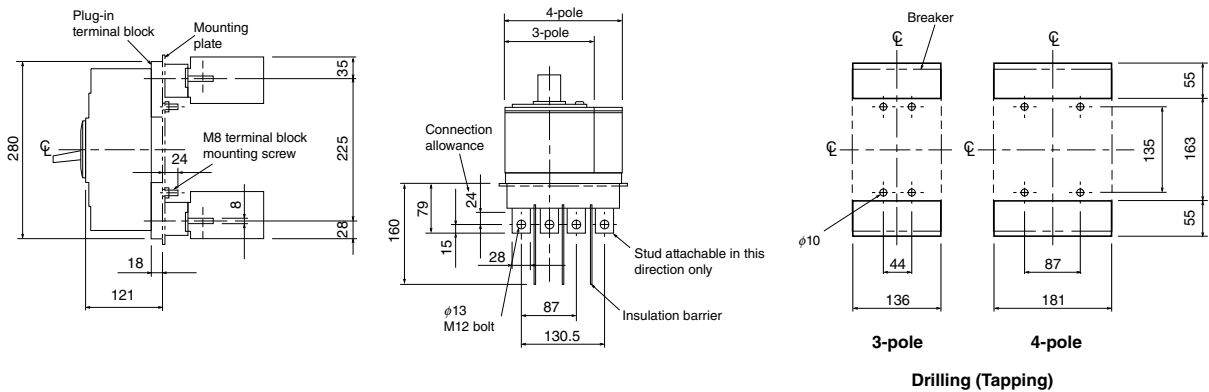

## NV630-CW NV630-SW



NV630-SW

Model		NV630-CW	NV630-SW
Rated current In (A) Reference ambient temperature 40°C		500 600 (630)	
Number of poles		3	
Phase line		3φ3W, 1φ3W, 1φ2W	
Rated operational voltage Ue (V)		AC 200-440	
High-speed type	Rated current sensitivity (mA)	-	
	Max operating time (s)	at IΔn	-
		at 5IΔn	-
Time-delay type	Rated current sensitivity (mA)	100 · 200 · 500 Selectable	
	Max operating time (s)	0.45 · 1.0 · 2.0 Selectable	
	Inertial operating time (s) (or more)	0.1 · 0.5 · 1.0	
Earth leakage protection characteristic		Type AC	
Earth-leakage indication system		Mechanical type (Button)	
Rated short-circuit breaking capacity (kA) IEC 60947-2 (Icu/Ics) EN 60947-2	AC	440V	36/18 42/42
		415V	36/18 50/50
		400V	36/18 50/50
		230V	50/25 85/85
		200V	50/25 85/85
		100V	- -
Standard attached parts (Front connection)		Terminal screw: M12 boltx35 (3-pole: 6pcs) Mounting screw: M6x72 (4pcs) Insulation barrier: (4pcs)	

### Operating Characteristics

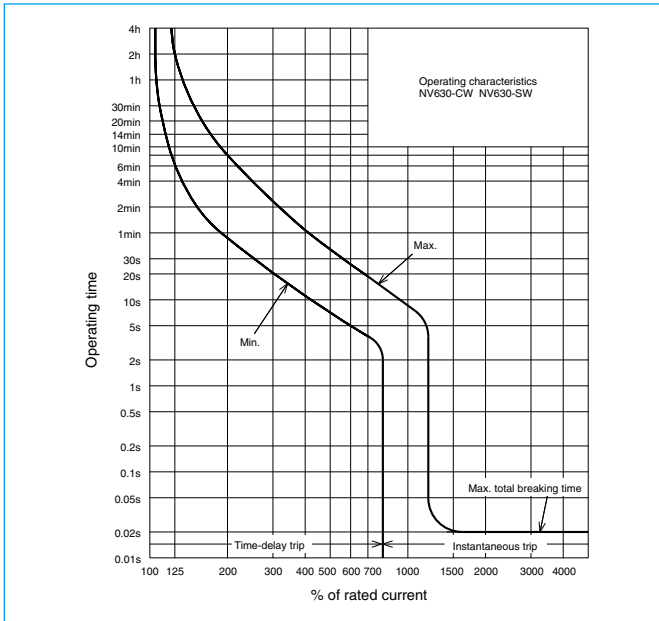

### Earth Leakage Tripping Characteristics

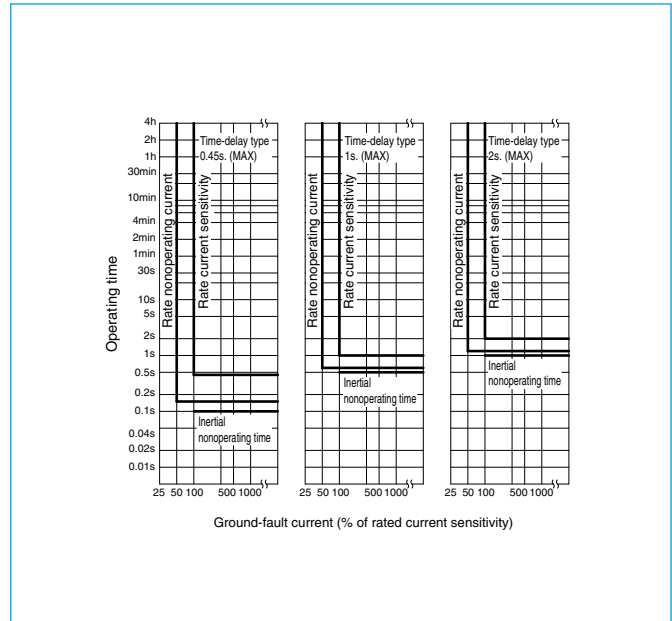

### Internal Accessories

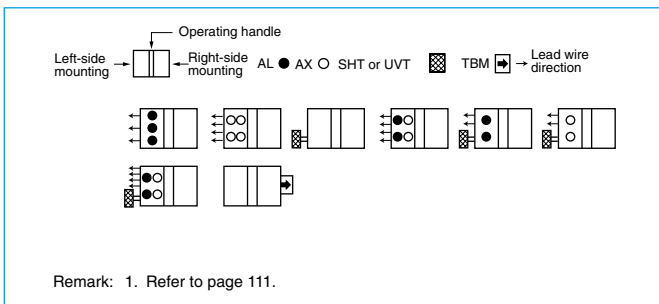

### Temperature Compensation Curve

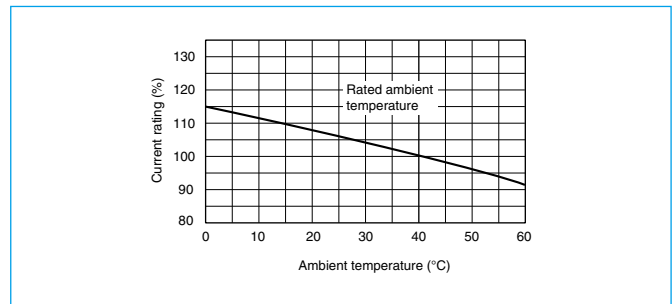

### External Accessories

Accessories	Type name	Reference page	Accessories	Type name	Reference page	
Operating handle	F	F-4S	123	Auxiliary handle	HT HT-4SW 135	
	V	V-4S	125	Terminal cover	Large	TC-L TCL-4SW3 128
Mechanical interlock	MI	MI-4SW3	136		Skeleton	TTC TTC-4SW3 128
					Rear	BTC BTC-4SW3 134
				Handle lock device	HL HL-4SW 134	
				HL-S	HLS-4SW 134	
				Electrical operation device	(*1) 140	

Note \*1 Specify the operation method and voltage. Order in combination with the breaker unit.

### Internal Wiring Diagram

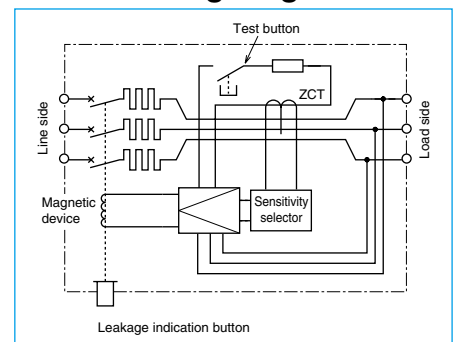

Outline Drawing

Front connection

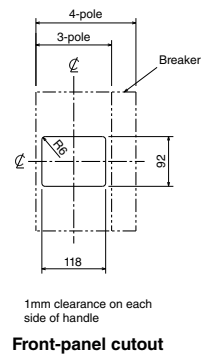
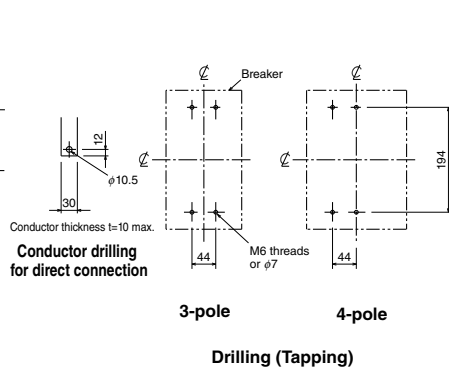
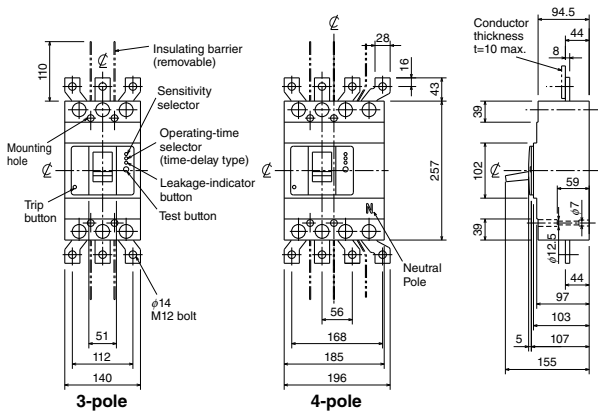

Rear connection

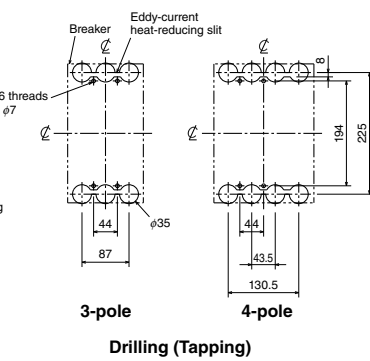
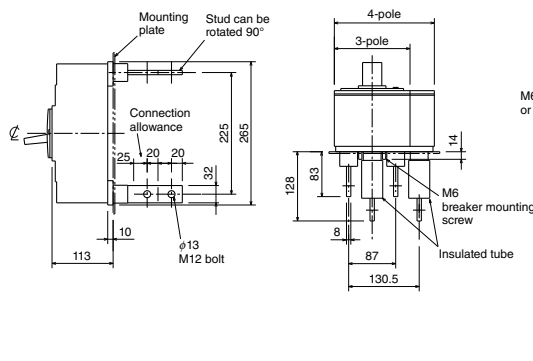

Boring dimensions for rear connection type barriers (3-pole)

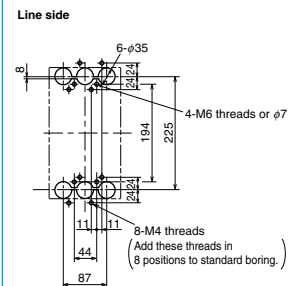

Note The bore dimensional drawing shows the breaker viewed from the rear.

Plug-in

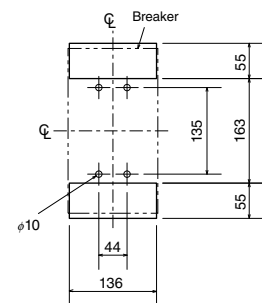
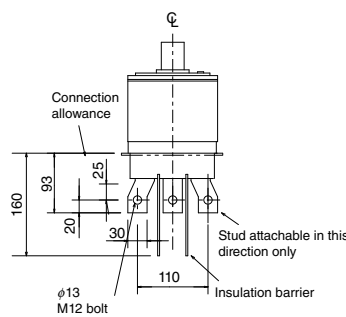
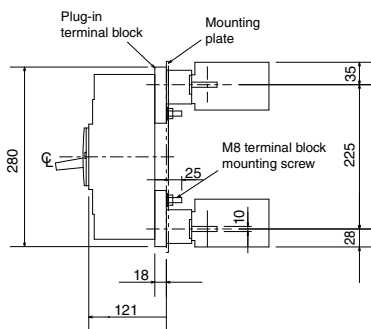

Drilling (Tapping)

## NV630-SEW NV630-HEW



NV630-SEW

Model		NV630-SEW	NV630-HEW
Rated current I <sub>n</sub> (A) Reference ambient temperature 40 °C		Adjustable 300 350 400 500 600 630	
Number of poles		3	4
Phase line		3P : 3φ3W, 1φ3W, 1φ2W 4P : 3φ4W	
Rated operational voltage U <sub>e</sub> (V)		AC 200-440	
High-speed type	Rated current sensitivity (mA)	-	
	Max operating time (s)	at IΔn -	
Time-delay type	Rated current sensitivity (mA)	(100 · 200 · 500 Selectable)	
	Max operating time (s)	(0.45 · 1.0 · 2.0 Selectable)	
Inertial operating time (s) (or more)		(0.1 · 0.5 · 1.0)	
Earth leakage protection characteristic		Type AC	
Earth-leakage indication system		Mechanical type (Button)	
Rated short-circuit breaking capacity (kA) IEC 60947-2 (I <sub>cu</sub> /I <sub>cs</sub> ) EN 60947-2	AC	440V	42/42
		415V	50/50
		400V	50/50
		230V	85/85
		200V	85/85
		100V	-
Standard attached parts (Front connection)		Terminal screw: M12 boltx35 (3-pole: 6pcs, 4-pole: 8pcs) Mounting screw: M6x72 (4pcs) Insulation barrier: (3P: 4pcs, 4P: 6pcs)	

### Operating Characteristics

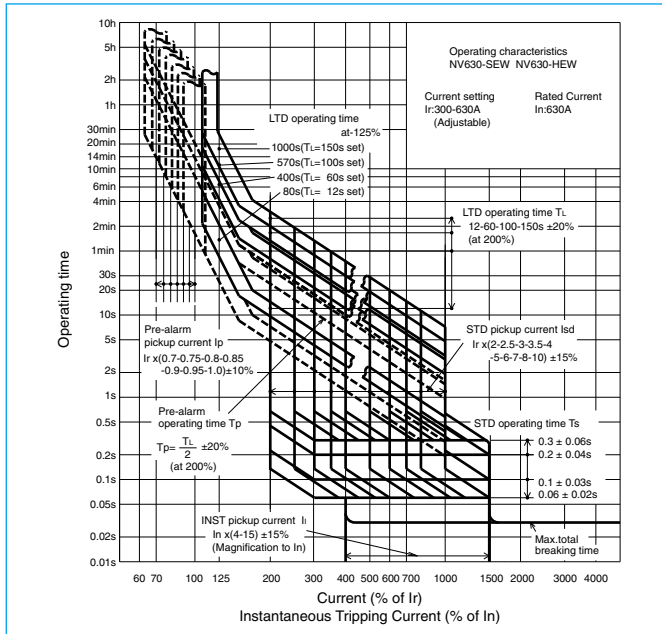

### Earth Leakage Tripping Characteristics

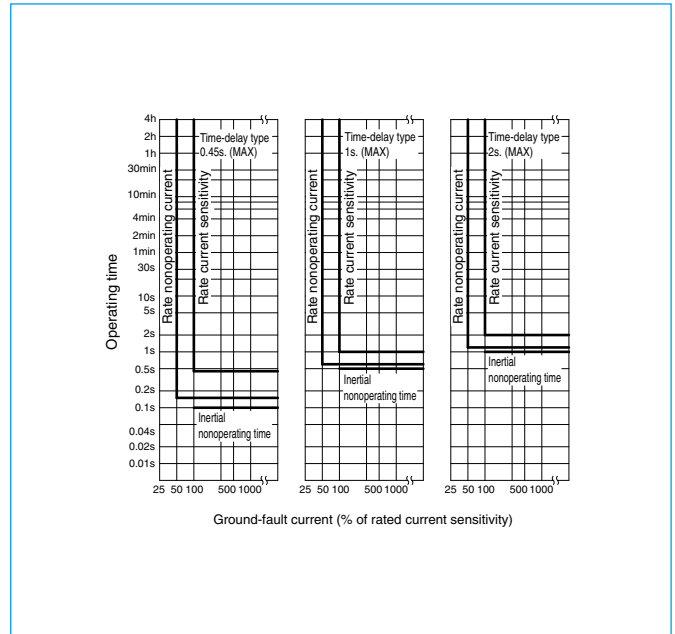

### Internal Accessories

Remarks: 1. Instead of TBM, pre-alarm module (PAL) can be attached.  
2. Refer to page 111.

### Current Reducing Curve

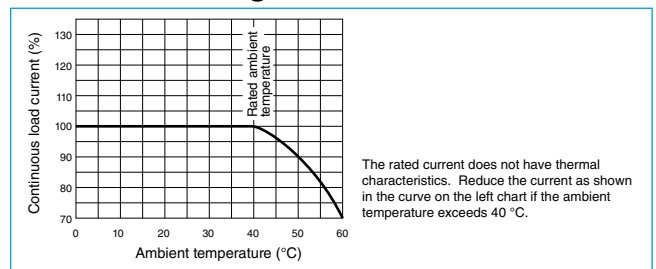

### External Accessories

Accessories	Type name	Reference page	Accessories	Type name	Reference page	
Operating handle	F	F-4S	Auxiliary handle	HT	HT-4SW	
	V	V-4S				
Mechanical interlock	MI	3P MI-4SW3	Terminal cover	Large	TC-L	
		4P MI-4SW4			3P	TCL-4SW3 (*1)
					4P	TCL-4SW4 (*1)
				Skeleton	TTC	3P TTC-4SW3
					4P TTC-4SW4	
			Rear	BTC	3P BTC-4SW3 (*2)	
					4P BTC-4SW4	
Handle lock device	HL	HL-4SW	Electrical operation device	NVM	3P (*3)	
	HL-S	HLS-4SW			4P	

Notes  
\*1 This is for NV630-SEW.  
\*2 This is for NV630-SEW. For rear terminal cover of NV630-HEW, use PTC-4SW3.  
\*3 Specify the operation method and voltage. Order in combination with the breaker unit.

### Internal Wiring Diagram

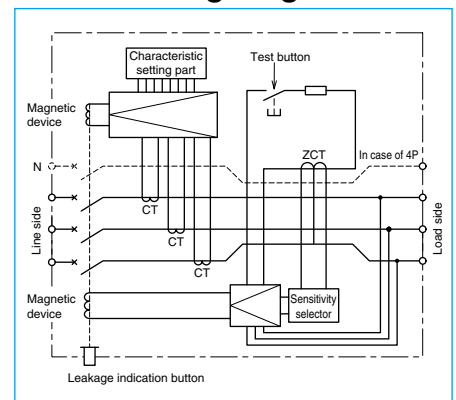

Outline Drawing

Front connection

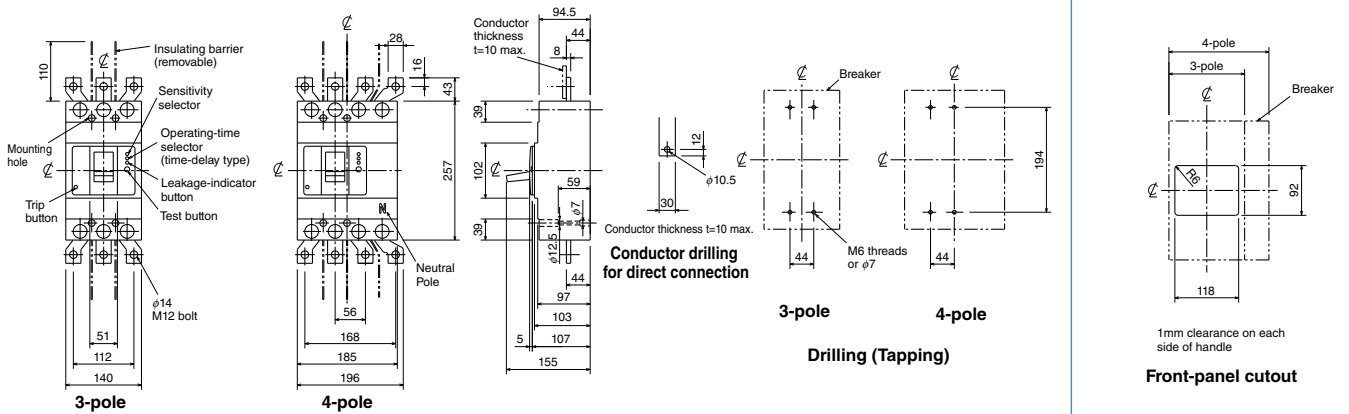

Rear connection

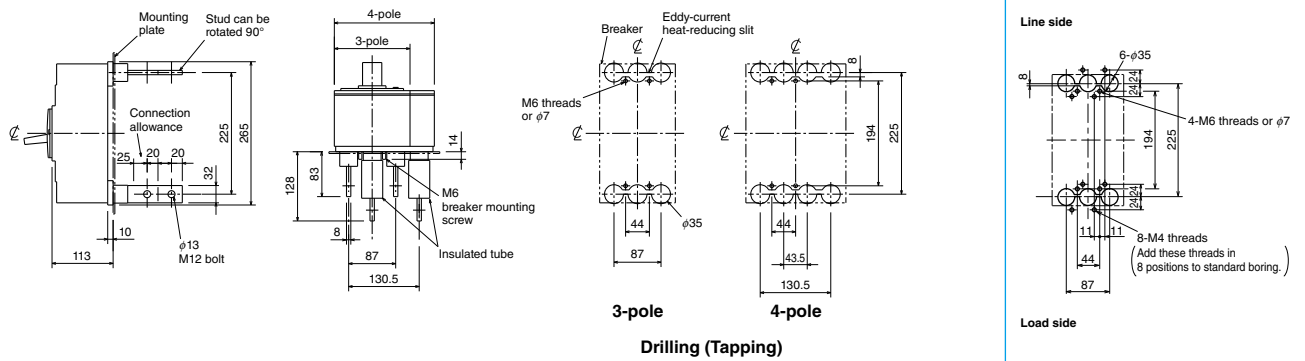

Plug-in

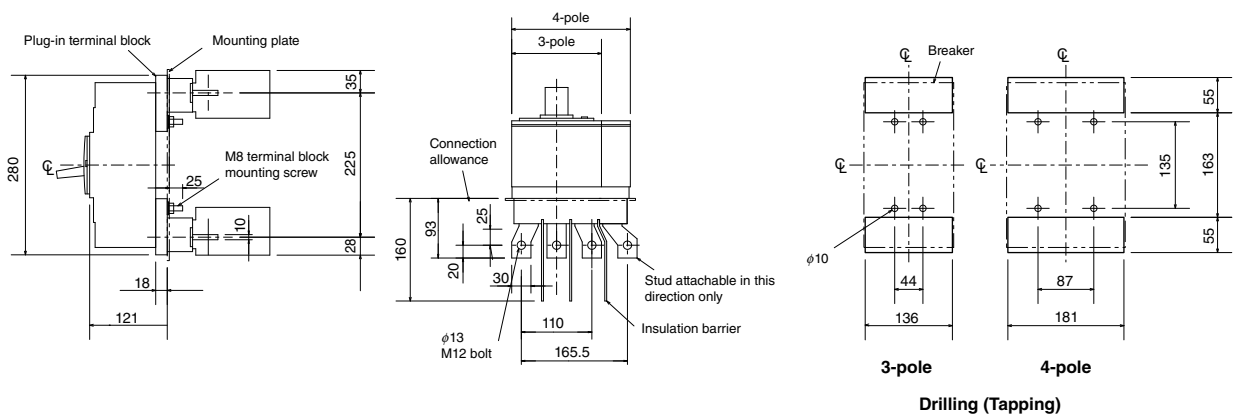

## NV800-SEW NV800-HEW



NV800-SEW

Model		NV800-SEW	NV800-HEW
Rated current $I_n$ (A) Reference ambient temperature 40°C		Adjustable 400 450 500 600 700 800	
Number of poles		3	
Phase line		3 $\phi$ 3W, 1 $\phi$ 3W, 1 $\phi$ 2W	
Rated operational voltage $U_e$ (V)		AC 200-440	
High-speed type	Rated current sensitivity (mA)	-	
	Max operating time (s)	at $I_{\Delta n}$	-
		at $5I_{\Delta n}$	-
Time-delay type	Rated current sensitivity (mA)	100 · 200 · 500 Selectable	
	Max operating time (s)	0.45 · 1.0 · 2.0 Selectable	
	Inertial operating time (s) (or more)	0.1 · 0.5 · 1.0	
Earth leakage protection characteristic		Type AC	
Earth-leakage indication system		Mechanical type (Button)	
Rated short-circuit breaking capacity (kA) IEC 60947-2 (Icu/Ics) EN 60947-2	AC	440V	42/42      65/65
		415V	50/50      70/70
		400V	50/50      70/70
		230V	85/85      100/100
		200V	85/85      100/100
		100V	-              -
Standard attached parts (Front connection)		Terminal screw: M12 boltx35 (3-pole: 12pcs) Mounting screw: M6x35 (4pcs) Insulation barrier: (2pcs)	

### Operating Characteristics

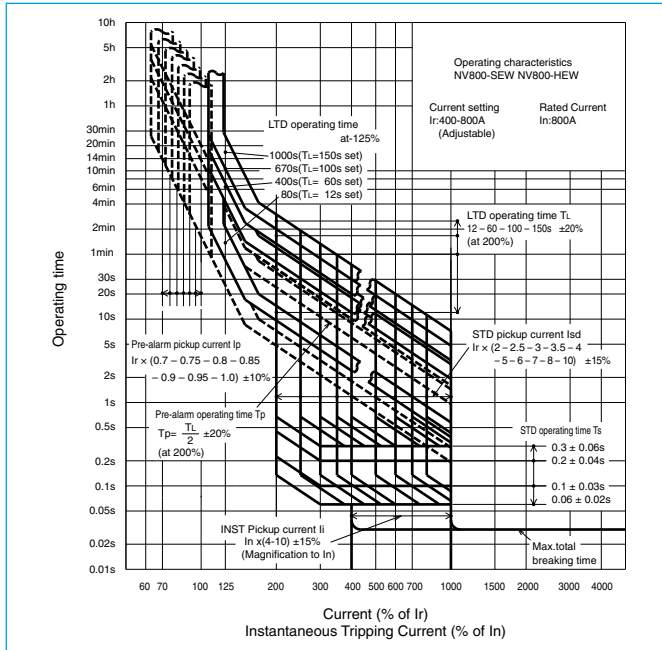

### Earth Leakage Tripping Characteristics

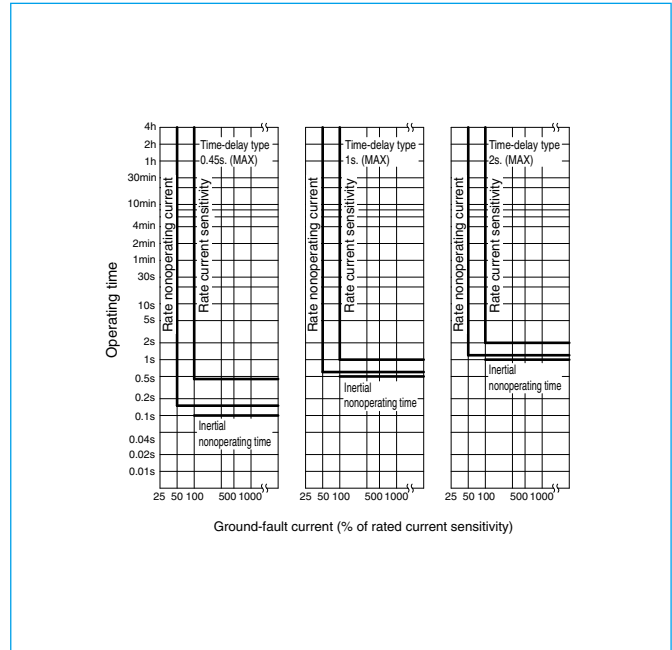

### Internal Accessories

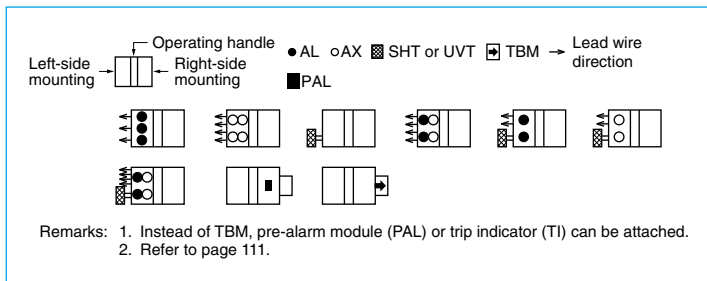

### Current Reducing Curve

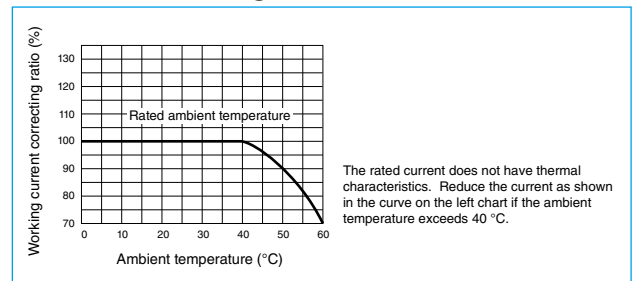

### External Accessories

Accessories	Type name	Reference page	Accessories	Type name	Reference page
Operating handle	F	F-8S	Auxiliary handle	HT	HT-4SW
	V	V-8S			135
Mechanical interlock	MI	MI-8SW3	Terminal cover	Large	TC-L
				Skeleton	TTC
				Rear	BTC
			Handle lock device	HL	HL-4SW
				HL-S	HLS-8SW
			Electrical operation device	(*)1	140

Note \*1 Specify the operation method and voltage. Order in combination with the breaker unit.

### Internal Wiring Diagram

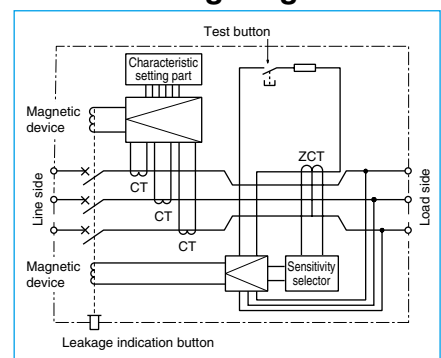

Outline Drawing

Front connection

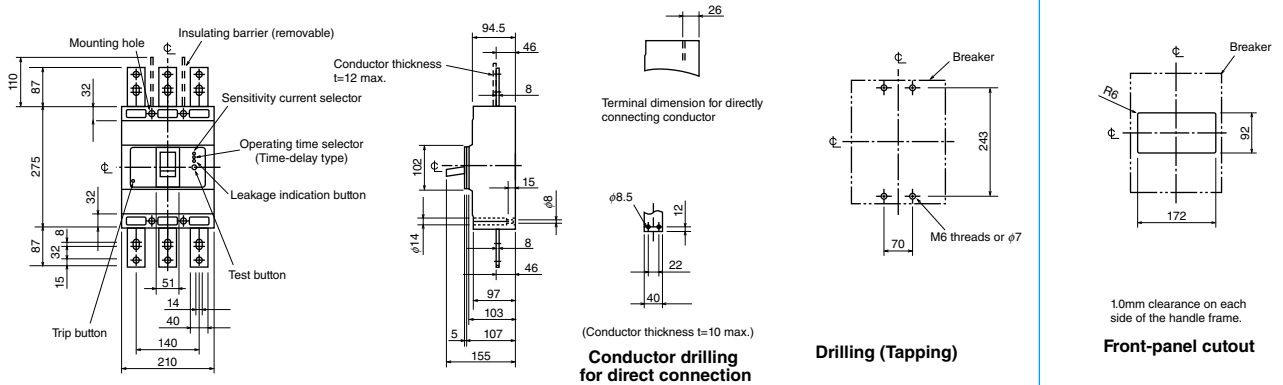

Rear connection

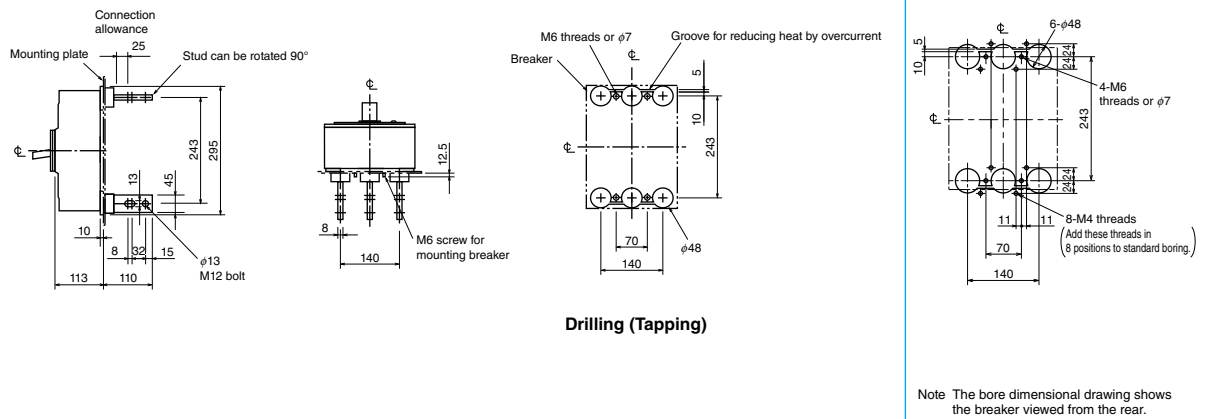

Plug-in

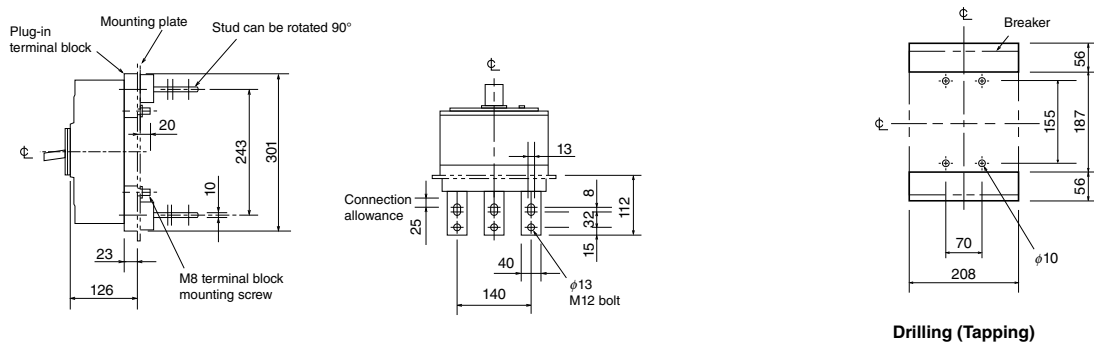

## NF50-SMU



NF50-SMU

Model			NF50-SMU		
Rated current In (A) Reference ambient temperature 40°C			0.5 1 1.5 2 3 4 5 6 7 8 10 13 15 20 25 30 35 40 50		
Number of poles			1	2	3
Rated short-circuit breaking capacity (kA)	UL 489 CSA C22.2 No.5	AC	240V	5	10
			120V	10	-
		DC	60V	10	-
	Rated insulation voltage Ui V		440		
	IEC 60947-2 EN 60947-2 (Icu/Ics)	AC	400V	-	10/7.5
			230V	10/7.5	10/7.5
DC		60V	10/7.5	-	

Note \*1 The handle does not indicate the trip position due to automatic reset structure.

### Operating Characteristics

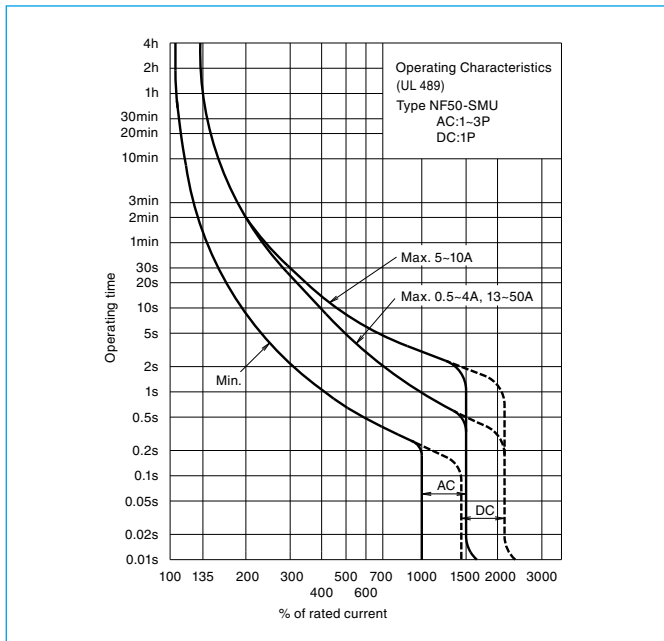

### Temperature Compensation Curve

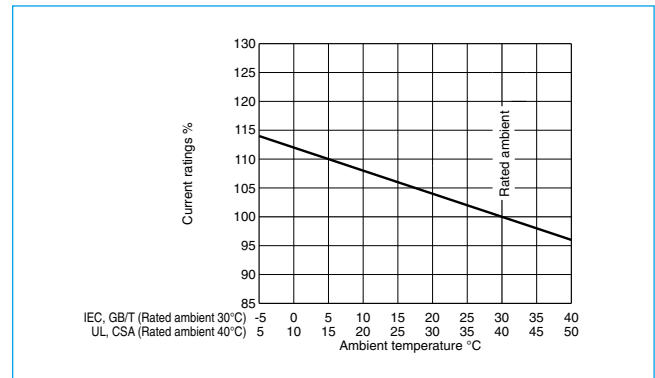

### External Accessories

Accessories	Type name	Reference page
AL	AL-05SMU	203
AX	AX-05SMU	
SHT	SHT024-05SMU SHTA130-05SMU SHT048-05SMU SHTA277-05SMU SHTD130-05SMU	203
HL	HLF-05SMU	134

Outline Drawing

Front connection

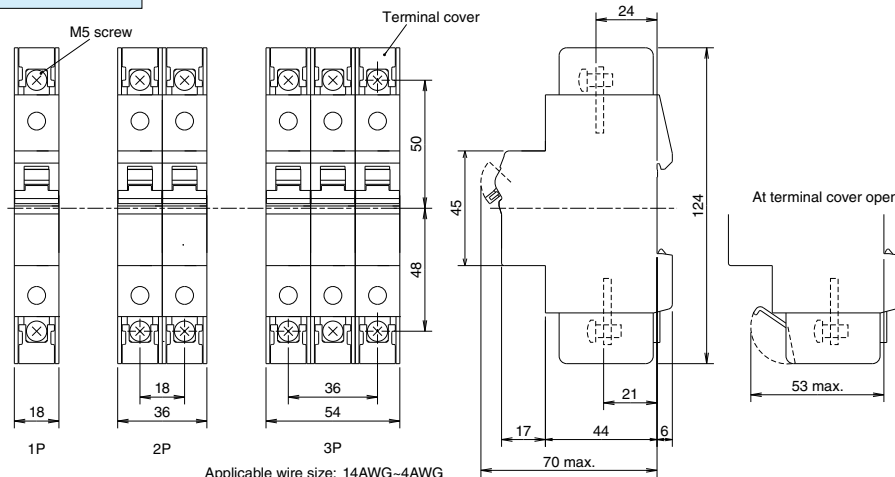

Applicable wire size: 14AWG-4AWG  
 1mm<sup>2</sup>-22mm<sup>2</sup>

Remark : The wires cannot be connected directly.

Applicable crimp terminal torque 18 lb-in. (2N-m)

mm <sup>2</sup>	AWG (#) (75°C)	Crimp terminal model (*1)	
		JST	NTM
0.65-1.65	18-16	R1.25-5	R1.25-5
1.04-2.63	16-14	R2-5	R2-5
		2-M5	R2-5M
		V2-5	
2.63-4.6	12	-	R3.5-5S
			R3.5-5L
2.63-6.64	12-10	R5.5-5	R5.5-5
		V5.5-5	R5.5-5S
			R5.5-5N
6.64-10.52	8	R8-5	R8-5
			R8-5S
10.52-16.78	6	R14-5	R14-5
		14-NK5	R14-5S
16.78-26.66	4	-	R22-5S

JST: Japan Solderless Terminal Mfg. Co.  
 NTM: Nichifu Co., Ltd.  
 Note \*1 When using in wire connection use crimp terminal in the table.

AL/ AX

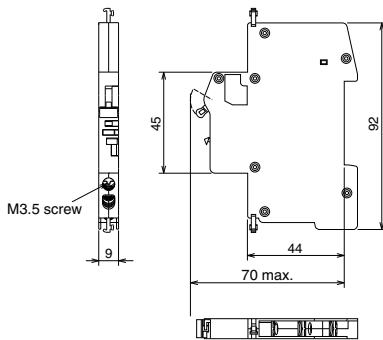

Applicable wire size: 14AWG  
 1mm<sup>2</sup>-2.5mm<sup>2</sup>  
 Note: The ring tongue crimp terminal can not be connected.

SHT

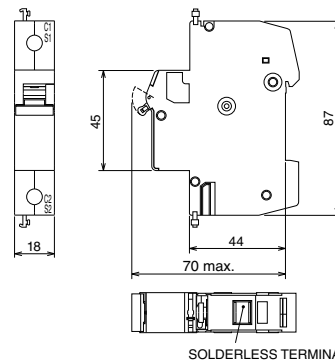

Applicable wire size: 14AWG  
 1mm<sup>2</sup>-2.5mm<sup>2</sup>

Type Name	Alarm switch (AL)	Auxiliary switch (AX)
	AL-05SMU	AX-05SMU
Configuration	1c	1c
Contact capacity	277VAC 3A 240VAC 6A 130VDC 1A 48VDC 2A 24VDC 6A	
Terminal	Load side (OFF side)	
Terminal connection	Clamp terminal M3.5 (*1)	
Dimension (mm)	a	9
	b	92
	c	44
	ca	70
Mass (kg)	0.05	

Note \*1 Ring tongue crimp terminal can not be connected.

Terminal Symbol

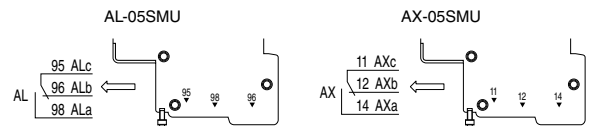

Type Name	Shunt trip device (SHT)				
	SHT024-05SMU	SHTA130-05SMU	SHT048-05SMU	SHTA277-05SMU	SHTD130-05SMU
Voltage V	AC24/DC24	AC48-130	AC48/DC48	AC220-277	DC110-130
Input power requirement (VA) (*2)	60	200	70	70	105
Operating time (ms) (*3)	20 or less				
Terminal connection	Solderless				
Dimension (mm)	a	18			
	b	87			
	c	44			
	ca	70			
Mass (kg)	0.1				

Note \*2 Secure a sufficient input power so that the voltage will not drop below the permissible lower working voltage (70% of the lowest rated voltage).  
 \*3 The operating time denotes the time from when the rated voltage is applied to SHT until when the main contact of the breaker starts to open.

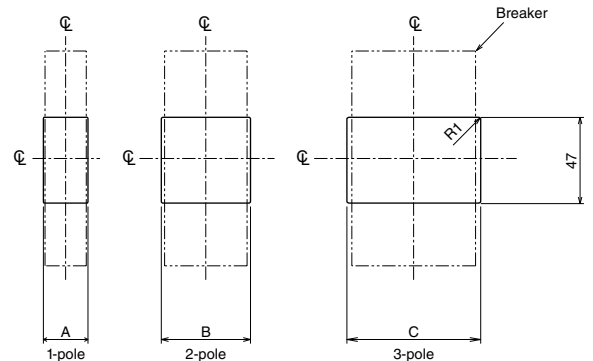

Front-panel cutout

Rate of dimensional change (Front-plate cutout)

Pole	Width	Accessory (mm)					
		No accessory	AL or AX	AL or 2 pcs AX	SHT1	AL or AX with SHT	AL or 2 pcs AX with SHT
1	A	20	29	38	38	47	56
2	B	38	47	56	56	65	74
3	C	56	65	74	74	83	92

## NF50-SVFU NV50-SVFU



NV50-SVFU

Model		NF50-SVFU		Model		NV50-SVFU			
Rated current I <sub>n</sub> (A) Reference ambient temperature 40°C		(3) 5 10 15 20 30 40 50		Rated current I <sub>n</sub> (A) Reference ambient temperature 40°C		(5) (10) 15 20 30 40 50			
Number of poles		2   3		Number of poles		2   3			
Rated short-circuit breaking capacity (kA)	UL 489 CSA C22.2 No.5	Rated voltage VAC	240	Rated voltage VAC	UL 489		120-240		
			600Y/347V		-	IEC 60947-2 EN 60947-2	100-240	100-440	
			480V		-		High-speed type	Rated current sensitivity I $\Delta$ n mA	30 50   30 50 100
			480Y/277V		-	Pick-up current UL 1053		75% of I $\Delta$ n	
	240V	14	Operating time (sec) within AT 5I $\Delta$ n	0.04 (*1)					
Rated short-circuit breaking capacity (kA)	IEC 60947-2 EN 60947-2 (Icu/Ics)	Rated insulation voltage U <sub>i</sub> V	440	Earth-leakage indication system		Indicator window			
			690V	-	UL 489 CSA C22.2 No.5	AC	480V	-	
			500V	-		AC	240V	14	
			440V	7.5/4	IEC 60947-2 EN 60947-2 (Icu/Ics)	AC	440V	-	7.5/4
			415V	10/5			400V	-	10/5
			400V	10/5			230V	15/8	15/8
			380V	10/5			100V	15/8	15/8
230V	15/8								
Standard attached parts (Front connection)		Terminal screw: M5x14 (2P: 4pcs, 3P: 6pcs) IEC35 rail mounting claws		Standard attached parts (Front connection)		Terminal screw: M5x14 (2P: 4pcs, 3P: 6pcs) IEC35 rail mounting claws			

Note \*1 0.1 for UL1053.

Remark: 1. The mounting screws must be prepared by the user. (Recommended size: M4×0.7×65 (2 pcs).)

### Operating Characteristics

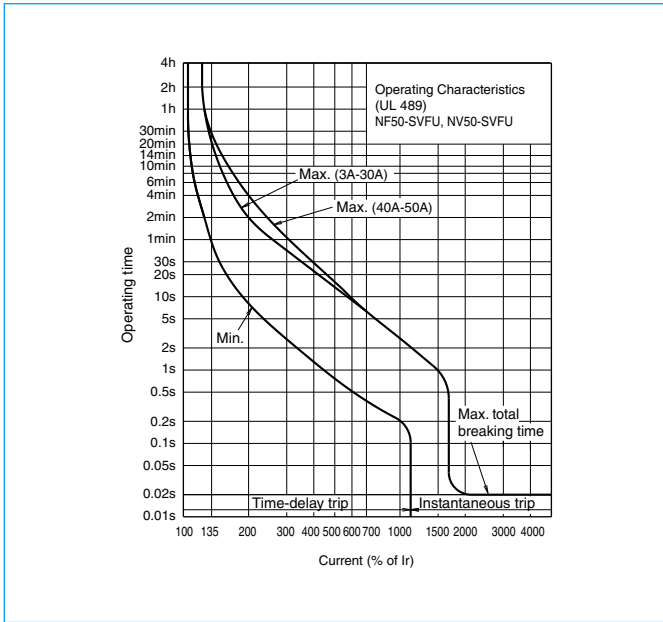

### Earth Leakage Tripping Characteristics

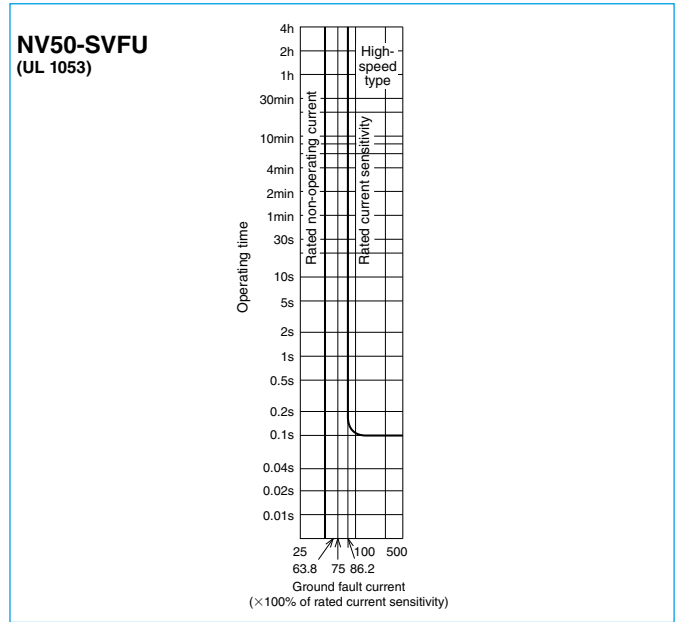

### Internal Accessories

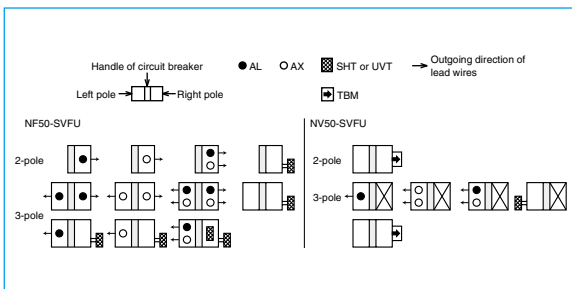

### Temperature Compensation Curve

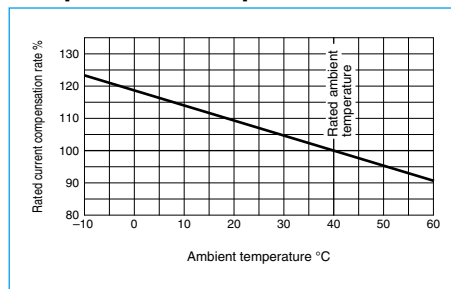

### Internal Wiring Diagram

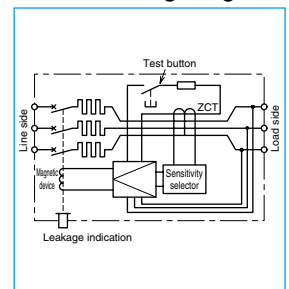

### External Accessories

Accessories			Type name	Reference page	Accessories			Type name	Reference page	
Operating handle	F	2P	F-03SVUL2	123	Terminal cover	Large	2P	TCL-03SVU2	128	
		3P	F-03SVUL				3P	TCL-03SVU3		
	V	2P	V-03SVUL2	125						
		3P	V-03SVUL							
Handle lock device	HL	HLF-03SVU		134						
	HL-S	HLS-03SVU								

Outline Drawing

Front connection

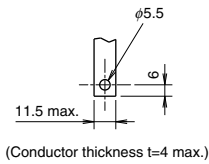
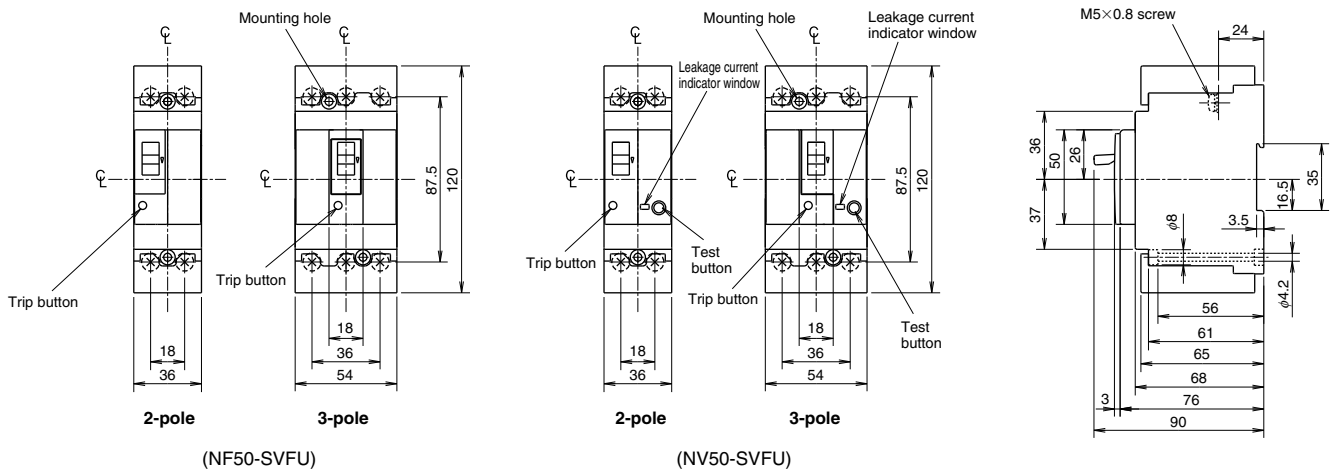

Conductor drilling for direct connection

Remarks: 1. The mounting screws are not enclosed with the breaker.  
 2. The wires cannot be connected directly.

Compatible crimp terminals Tightening torque 22lb-in (2.5N·m)

Applicable wire range (*1)	Crimp terminal type (*2)		
	mm <sup>2</sup>	AWG (#) (60°C/75°C)	JST
2.5-2.63	14	R2-5 2-M5 V2-5 V2-M5	R2-5 R2-5M
2.63-4.6	12	-	R3.5-5S R3.5-5L
2.63-6.64	12-10	R5.5-5 V5.5-5	R5.5-5 R5.5-5S R5.5-5N
6.64-10.52	8	R8-5	R8-5 R8-5S
10.52-16.78	6	R14-5 14-NK5	R14-5 R14-5S
16.78-26.66	4	22-S5 22-S6	R22-5S

JST: Japan Solderless Terminal Mfg. Co.  
 NTM: Nichifu Co., Ltd.  
 Notes \*1 14AWG or larger to comply with UL Standards.  
 \*2 When using with a wire connection, use the crimp terminal combination shown above.

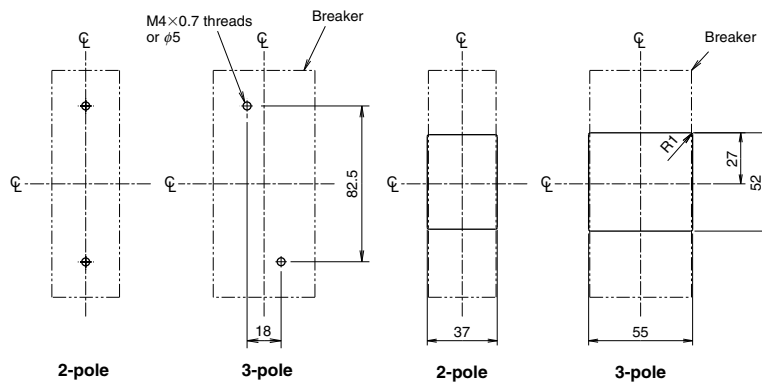

Drilling (Tapping)

Front-panel cutout

The drilling dimensions have a 1.0mm clearance on each side of breaker window frame.

## NF100-CVFU NV100-CVFU



NF100-CVFU

Model		NF100-CVFU		Model		NV100-CVFU			
Rated current I <sub>n</sub> (A) Reference ambient temperature 40°C		60 (70) 75 (80) (90) 100		Rated current I <sub>n</sub> (A) Reference ambient temperature 40°C		60 (70) 75 (80) (90) 100			
Number of poles		2   3		Number of poles		3			
Rated short-circuit breaking capacity (kA)	UL 489 CSA C22.2 No.5	AC	Rated voltage VAC	240	Phase line	3φ3W 1φ2W			
			600V/347V	-		Rated voltage VAC	UL 489 120-240		
			480V	-			IEC 60947-2 100-440		
			480V/277V	-			High-speed type	Rated current sensitivity I <sub>Δn</sub> mA	
240V	14	30 50 100/200/500 selectable							
Rated short-circuit breaking capacity (kA)	IEC 60947-2 EN 60947-2 (I <sub>cu</sub> /I <sub>cs</sub> )	AC	Rated insulation voltage U <sub>i</sub> V	600	Pick-up current UL 1053		75% of I <sub>Δn</sub>		
			690V	-	Operating time (sec) within AT 5I <sub>Δn</sub>		0.04 (*1)		
			500V	7.5/4	Earth-leakage indication system		Mechanical button		
			440V	10/5	Rated short-circuit breaking capacity (kA)	UL 489 CSA C22.2 No.5	AC	480V	-
			415V	10/5				240V	14
			400V	10/5				120V	14
			380V	10/5				440V	10/5
230V	15/8	400V	10/5						
Standard attached parts (Front connection)		IEC35 rail mounting claws, Insulating barrier (2P: 2pcs, 3P: 4pcs) (Only for type with bar terminal) Mounting screw M4×0.7×55 (2 pcs) Terminal screw: M8×14 (2P: 4pcs, 3P: 6pcs)		Standard attached parts (Front connection)		IEC35 rail mounting claws, Insulating barrier (4pcs) (Only for type with bar terminal) Mounting screw M4×0.7×55 (2 pcs) Terminal screw: M8×14 (3P: 6pcs)			

Note \*1 0.1 for UL1053.

### Operating Characteristics

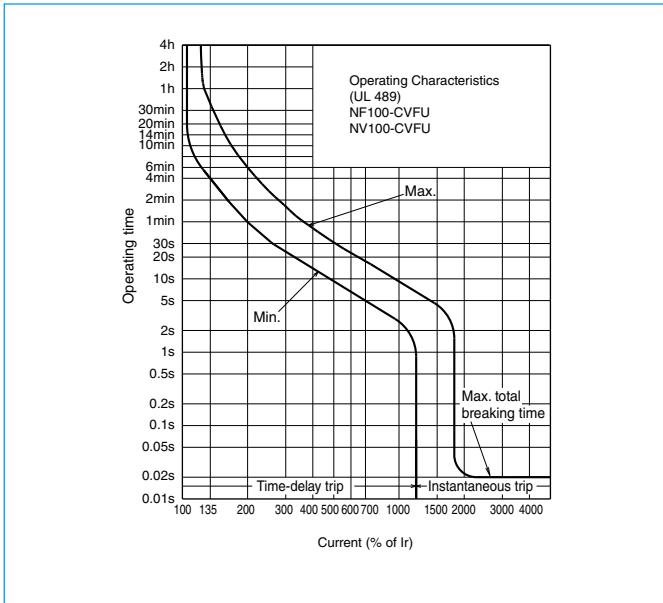

### Earth Leakage Tripping Characteristics

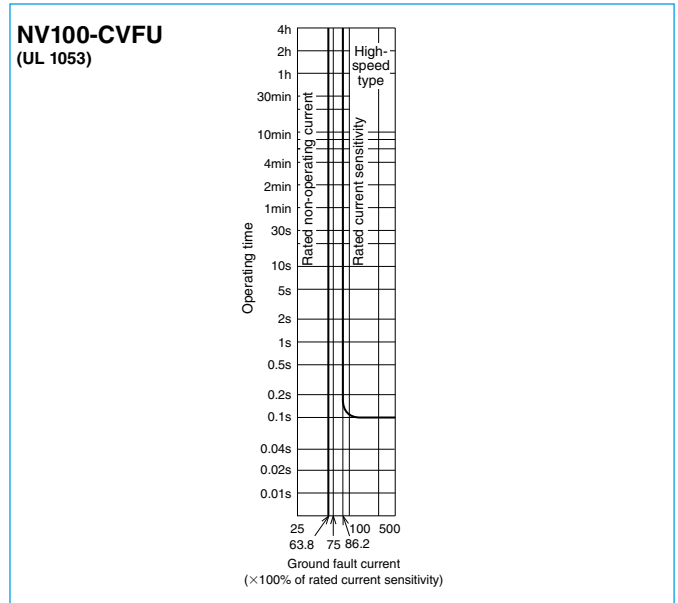

### Internal Accessories

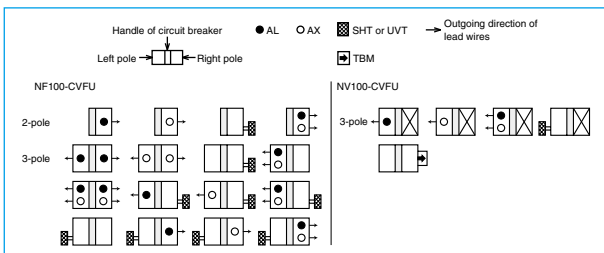

### Temperature Compensation Curve

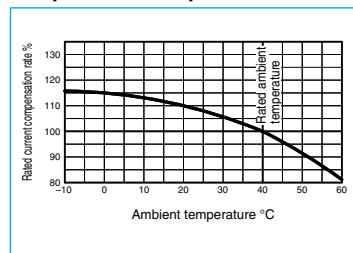

### Internal Wiring Diagram

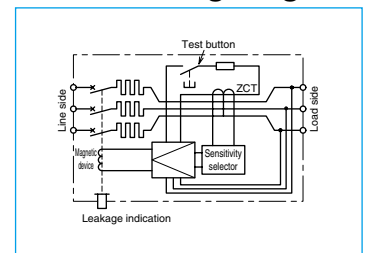

### External Accessories

Accessories			Type name	Reference page	Accessories			Type name	Reference page	
Operating handle	F	2P	F-05SVUL2	123	Terminal cover	Large	TC-L	2P	TCL-05SVU2	128
		3P	F-05SVUL					3P	TCL-05SVU2L	
	V	2P	V-05SVUL2	3P		TCL-05SVU3				
		3P	V-05SVUL			TCL-05SVU3L				
Handle lock device	HL		HLF-05SVU	134						
	HL-S	2P	HLS-05SVU2							
		3P	HLS-05SVU							

Outline Drawing

Front connection

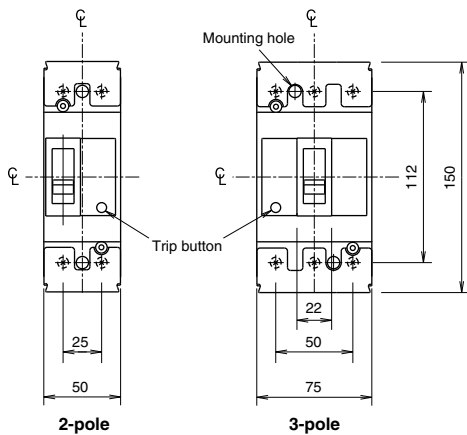

(NF100-CVFU)

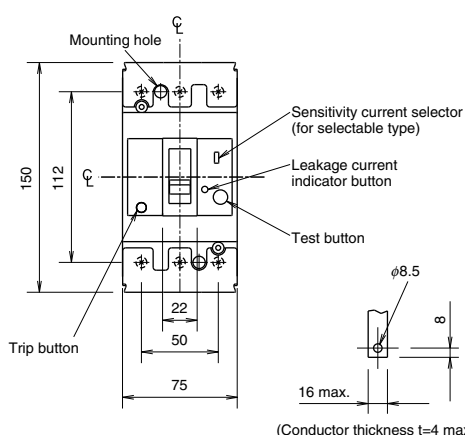

(NV100-CVFU)

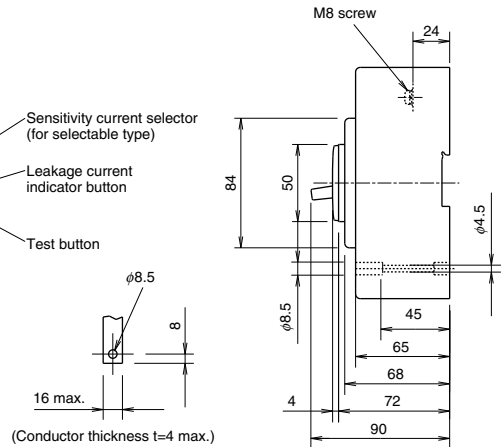

Conductor drilling for direct connection  
 (Conductor thickness t=4 max.)

Compatible crimp terminals Tightening torque 54lb-in (6N·m)

Applicable wire range	Crimp terminal type (*1)	
	mm <sup>2</sup>	AWG (#) (60°C/75°C)
2.5-2.63	14	R2-8
2.63-6.64	12-10	R5.5-8
6.64-10.52	8	R8-8
10.52-16.78	6	R14-8
16.78-26.66	4	R22-8
26.66-42.42	2	38-S8
42.42-60.57	1/0	60-2BA 60-S8
		NTM

JST: Japan Solderless Terminal Mfg. Co.  
 NTM: Nichifu Co., Ltd.  
 Note \*1 When using with a wire connection, use the crimp terminal combination shown above.

Front connection(solderless terminal)

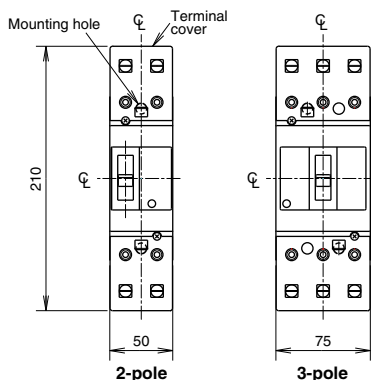

(NF100-CVFU)

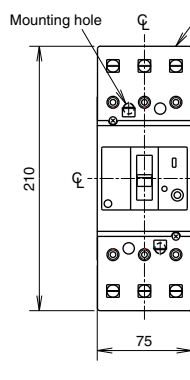

(NV100-CVFU)

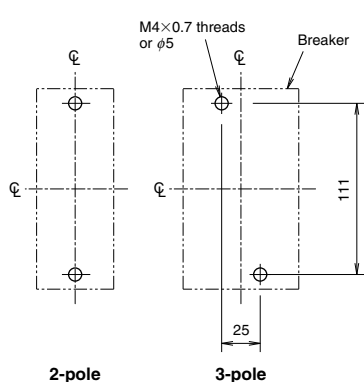
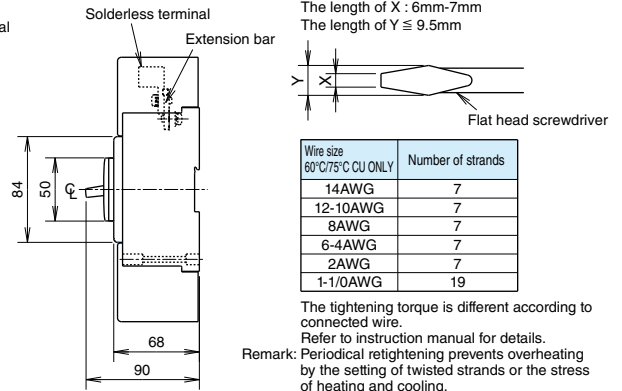

Drilling (Tapping)

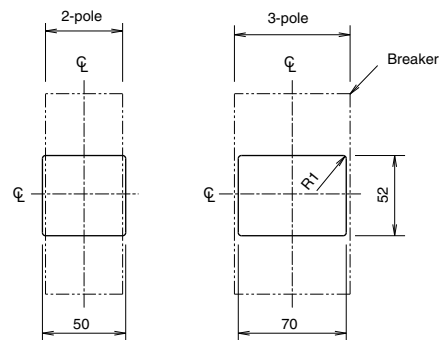

The drilling dimensions have a 1.0mm clearance on each side of breaker window frame.

Front-panel cutout

## NF100-SRU NF100-HRU NV100-SRU NV100-HRU



NF100-HRU 3P

Model		NF100-SRU				NF100-HRU			
Rated current In (A)		1	2	3	10	1	2	3	10
Reference ambient temperature 40°C		15	20	25	30	15	20	25	30
		40	50	60	70	40	50	60	70
		75	80	90	100	75	80	90	100
Number of poles		2		3		2		3	
Rated short-circuit breaking capacity (kA)	UL 489 CSA C22.2 No.5	AC	480V	-		18(10) (*1)		-	
			240V	35(25) (*1)		50(25) (*1)		-	
		690V	-		-		-		
		500V	10/5		18/9(10/5) (*1)		-		
		440V	15/8		25/13(15/8) (*1)		-		
	IEC 60947-2 EN 60947-2 (Icu/Ics)	AC	415V	15/8		25/13(15/8) (*1)		-	
			400V	15/8		25/13(15/8) (*1)		-	
		230V	35/18(25/13) (*1)		50/25(25/13) (*1)		-		
		DC	250V		-		-		
		Standard attached parts (Front connection)		Terminal screw: 50A or less M5x14 (2P: 4pcs, 3P: 6pcs) 60A or more M8x14 (2P: 4pcs, 3P: 6pcs) Mounting screw: M4x0.7x55 (NF100-SRU 2P, 3P: 2pcs) M4x0.7x62 (NF100-HRU 2P, 3P: 2pcs) Insulation barrier: (2P: 2pcs, 3P: 4pcs Only NF100-HRU)					

Notes \*1 Rated short-circuit breaking capacity parenthesized are applied to below rated current 15A.  
\*2 In case of UL1053, operating time is 0.1s.

Model		NV100-SRU			NV100-HRU						
Phase line		1φ2W		3φ3W, 1φ2W		3φ3W, 1φ2W					
Number of poles		2		3		3					
Rated operational voltage(UL489)(VAC)		120-240			120-240-480						
Rated operational voltage(IEC60947-2)(VAC)		100-230			100-230-440						
Rated current In (A)		5	10	15	20	5	10	15	20		
Reference ambient temperature 40°C		25	30	40	50	30	40	50	60		
		75	80	90	100	75	80	90	100		
Rated current sensitivity IΔn (mA)		30 50		100/300/500 selectable		30 50		100/300/500 selectable			
Pickup current UL1053		IΔn × 75%			IΔn × 75%						
Max. operating time (s) at 5 IΔn		0.04 (*2)			0.04 (*2)						
Leakage detection characteristics		Type A			Type A						
Earth-leakage indication system		Mechanical button			Mechanical button						
Rated short-circuit breaking capacity (kA)	UL 489 CSA C22.2 No.5	AC	480V	-		18(10) (*1)		-			
			240V	35(25) (*1)		50(25) (*1)		-			
		120V	35(25) (*1)		50(25) (*1)		-				
		440V	-		25/13(15/8) (*1)		-				
		400V	-		25/13(15/8) (*1)		-				
	IEC 60947-2 EN 60947-2 (Icu/Ics)	AC	230V	35/18(25/13) (*1)		50/25(25/13) (*1)		-			
			100V	35/18(25/13) (*1)		50/25(25/13) (*1)		-			
		Standard attached parts (Front connection)		Terminal screw: 50A or less M5x14 (2P: 4pcs, 3P: 6pcs) 60A or more M8x14 (2P: 4pcs, 3P: 6pcs) Mounting screw: M4x0.7x55 (NF100-SRU 2P, 3P: 2pcs) M4x0.7x62 (NF100-HRU 2P, 3P: 2pcs) Insulation barrier: (2P: 2pcs, 3P: 4pcs Only NF100-HRU)							

### Operating Characteristics

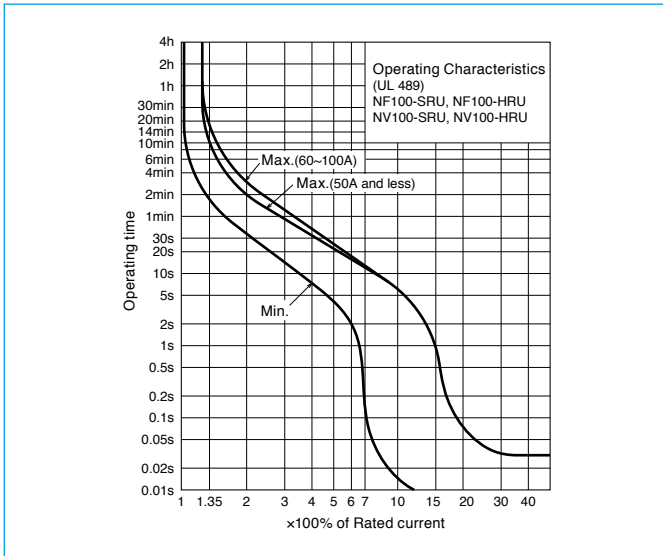

### Ground fault Tripping Characteristics

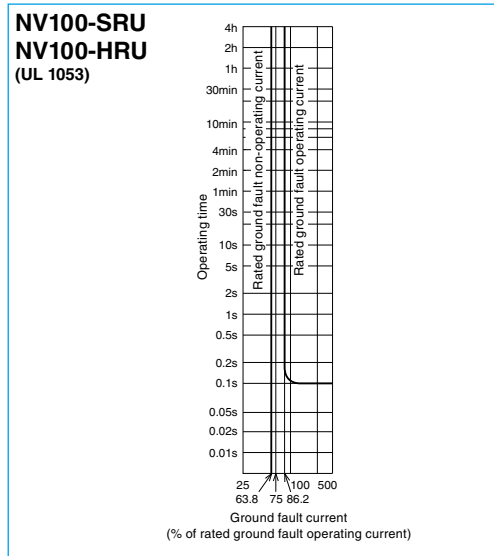

### Internal Accessories

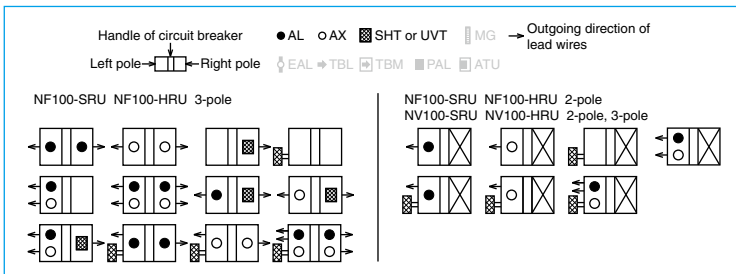

### Temperature Characteristics

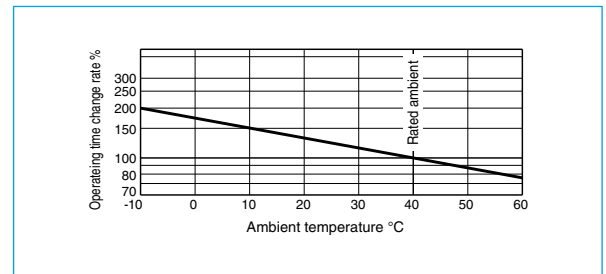

### External Accessories

Accessories		Type name	Reference page
Operating handle	F	2P F-05SRUL2	123
		3P F-05SRUL	
	V	2P V-05SRUL2	125
		3P V-05SRUL	
Handle lock device	HL	HLF-05SRU	134
		2P HLS-05SRU2	
	HL-S	3P HLS-05SRU3	
		2P TCS-05SRU2	
Small	3P TCS-05SRU3		
	Large	2P TCL-05SRU2	
3P TCL-05SRU3			

### Internal Wiring Diagram

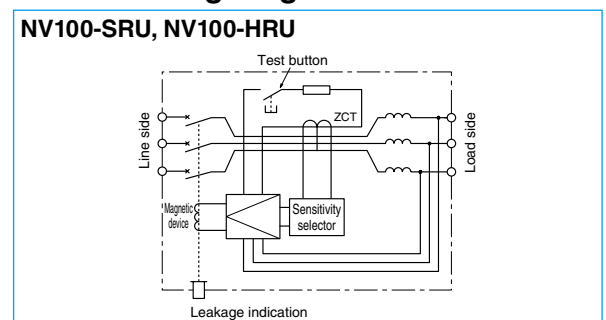

Outline Drawing

Front connection

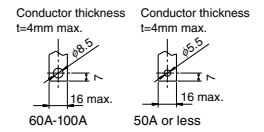
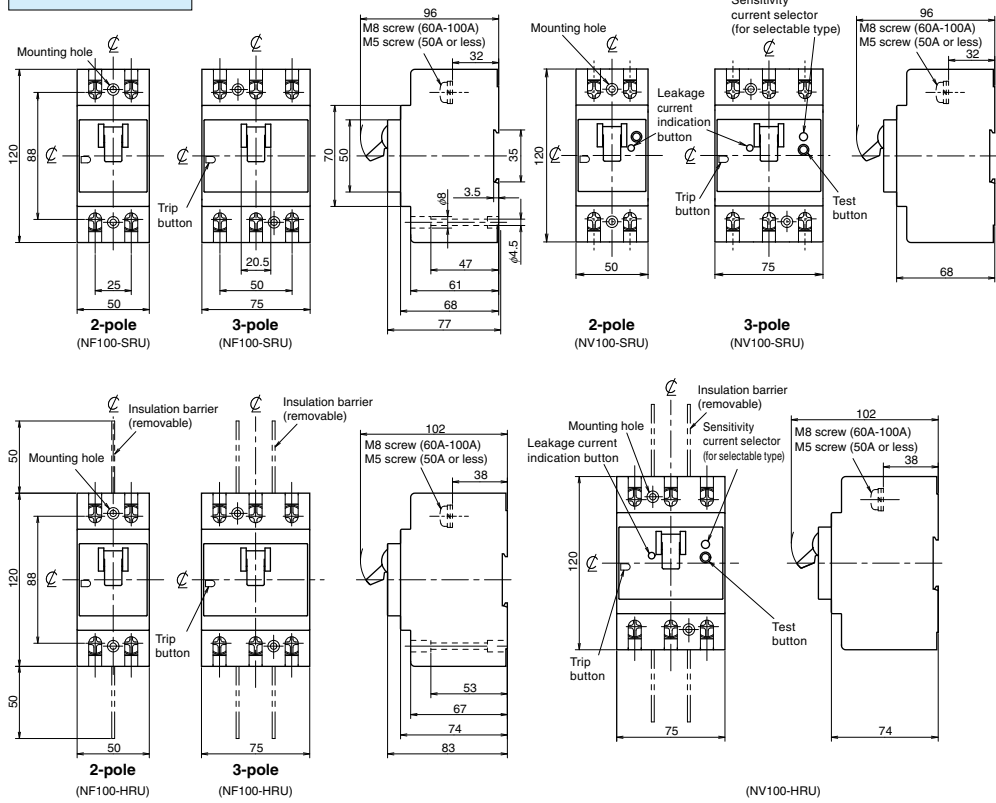

Conductor drilling for direct connection

Remark: The wires cannot be connected directly.  
 Tightening torque 26lb-in. (3N.m)

Compatible crimp terminals (50A or less)

Applicable wire range (*1)	Crimp terminal type (*2)
mm <sup>2</sup>	AWG(#) (60°C/75°C)
2.5 to 6.3	JST: R2-5, 2-M5 NTM: R2-5M, R2-5M
2.63 to 6.64	JST: R5.5-5, 5.5-S5 NTM: R5.5-5S, R5.5-5N
6.64 to 10.52	JST: R8-5 NTM: R8-5, R8-5S
10.52 to 16.78	JST: R14-5 NTM: R14-5, R14-5S
16.78 to 26.66	JST: 22-S6 NTM: R22-5S
26.66 to 42.42	JST: 38-S5 NTM: CB38-5S

JST: Japan Solderless Terminal Mfg. Co.  
 NTM: Nichifu Co., Ltd.  
 Notes \*1 14 AWG or larger to comply with UL standards.  
 \*2 When using with a wire connection, use the crimp terminal combination shown above.

Compatible crimp terminals (60A-100A)

Applicable wire range	Crimp terminal type (*2)
mm <sup>2</sup>	AWG(#) (60°C/75°C)
2.5 to 2.63	JST: R2-8 NTM: R2-8
2.63 to 6.64	JST: R5.5-8, 5.5-S8 NTM: R5.5-8
6.64 to 10.52	JST: R8-8 NTM: R8-8
10.52 to 16.78	JST: R14-8 NTM: R14-8, R14-8S
16.78 to 26.66	JST: 22-S8 NTM: R22-8S
26.66 to 42.42	JST: 38-S8 NTM: R38-8S
42.42 to 60.57	JST: CB60-8, 60-2BA NTM: CB60-8

Tightening torque 54lb-in. (6N.m)  
 JST: Japan Solderless Terminal Mfg. Co.  
 NTM: Nichifu Co., Ltd.

Front connection (solderless terminal)

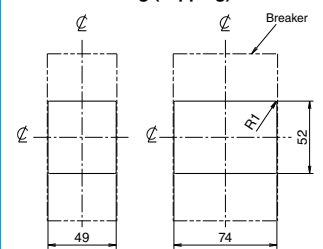
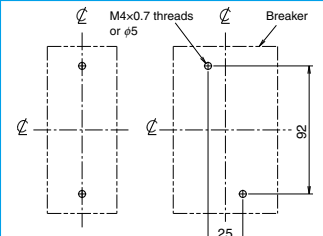
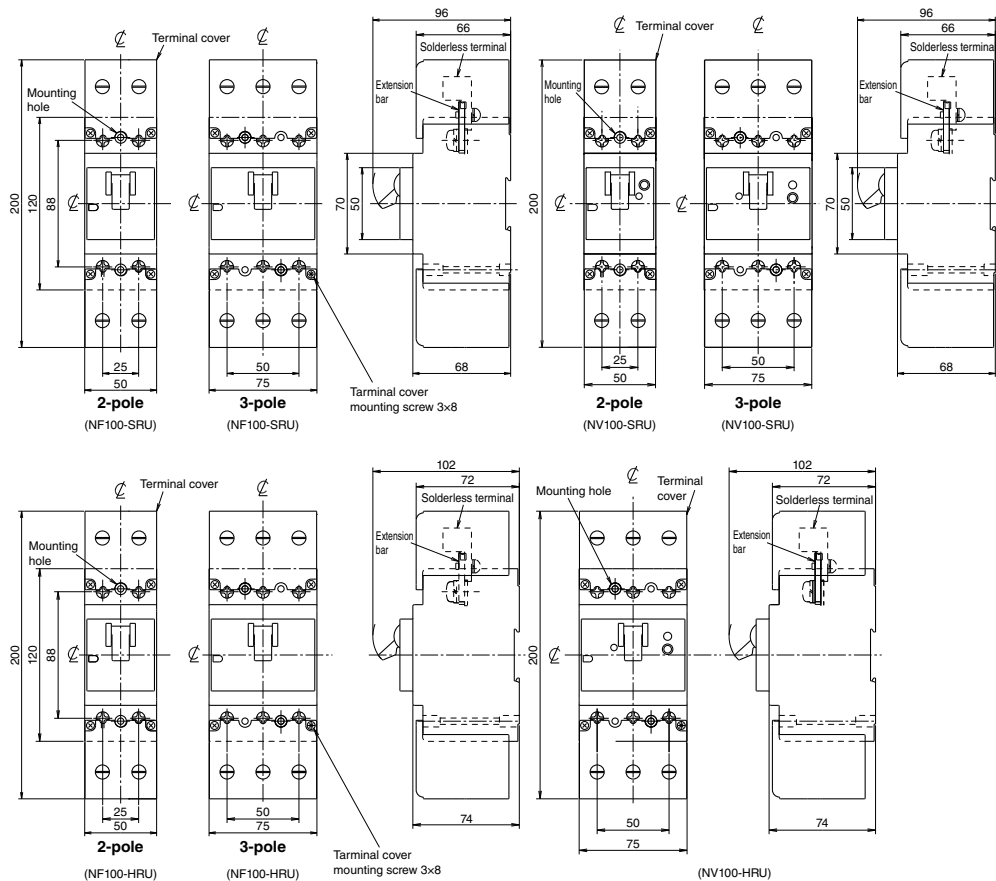

Size of screwdriver with bolting  
 Please bolt with flat head screwdriver.  
 The length of X: 6mm-7mm The length of Y: ≤ 9.5mm

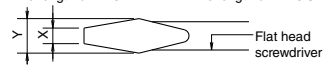

Wire size	Number of strands	
	Copper wire	Aluminum wire
14AWG	a* 7	-
12, 10AWG	a* 7	a* 7
8AWG	7	7
4, 6AWG	7	7
2AWG	7	7
1, 1/0AWG	19	19

The tightening torque is different according to connected wire.  
 Refer to instruction manual for details.  
 a: Solid wire is usable.  
 Remark: Periodical retightening prevents overheating by the setting of twisted strands or the stress of heating and cooling.

## NF125-SVU NF125-HVU NV125-SVU NV125-HVU



NF125-HVU

Model		NF125-SVU		NF125-HVU		Model		NV125-SVU		NV125-HVU		
Rated current I <sub>n</sub> (A) Reference ambient temperature 40°C		15	20	30	125	15	20	30	125	15	20	30
		(40)	(50)	(60)		(70)	(75)	(80)		(75)	(80)	(90)
		(90)	(100)			(90)	(100)			(75)	(100)	
Number of poles		2	3	2	3	3	3					
Rated short-circuit breaking capacity (kA)	UL 489 CSA C22.2 No.5	Rated voltage VAC		480	480	600Y/347V	600Y/347V					
		AC		480V	30	30	50	50				
			240V	50	50	100	100					
	IEC 60947-2 EN 60947-2 (Icu/Ics)		Rated insulation voltage U <sub>i</sub> V		690	690	690	690				
		AC		690V	8/4	8/4(4/4) (*2)	10/5(5/5) (*2)	10/5				
				500V	18/9	18/9(9/9) (*2)	25/13(13/13) (*2)	25/13				
				440V	30/15	30/15	50/25	50/25				
				415V	30/15	30/15	50/25	50/25				
				400V	30/15	30/15	50/25	50/25				
				380V	30/15	30/15	50/25	50/25				
				230V	50/25	50/25	100/50	100/50				
Standard attached parts (Front connection)		Terminal screw M8x14 (2P: 4pcs, 3P: 6pcs) Mounting screw M4x0.7x55 (2 screws), Insulating barrier (2P: 2pcs, 3P: 4pcs)										

Note \*1 0.1 for UL1053.  
\*2 Breaking capacities in parentheses apply to rated current of 15A and 20A.

## Operating Characteristics

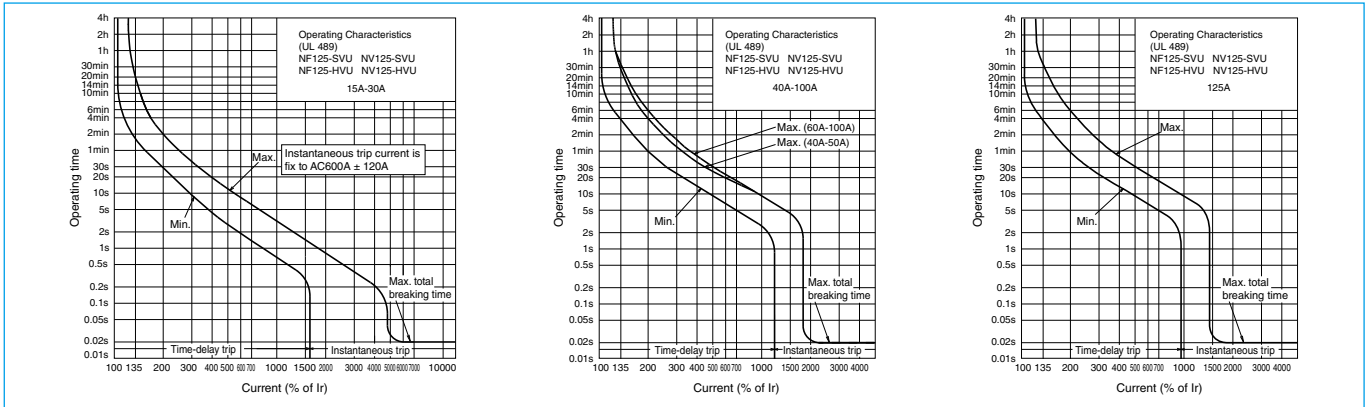

## Earth Leakage Tripping Characteristics

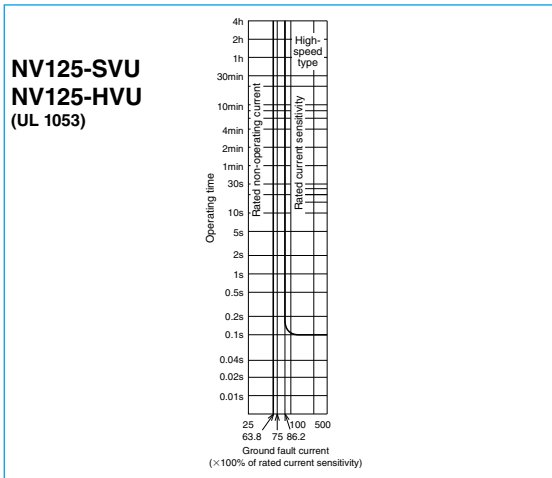

## Internal Accessories

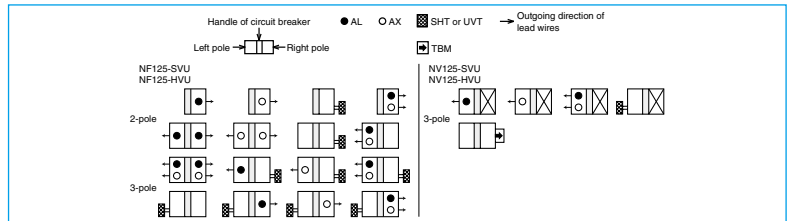

## Temperature Compensation Curve Internal Wiring Diagram

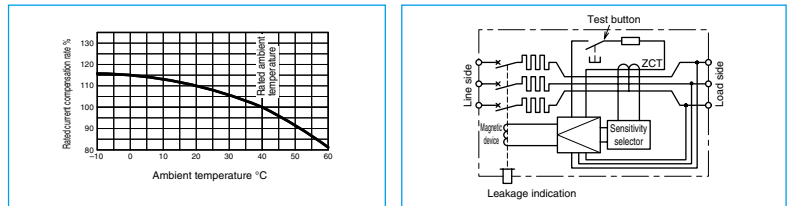

## External Accessories

Accessories	Type name	Reference page	Accessories	Type name	Reference page
Operating handle	F F-1SVUL	123	Terminal cover	Large TC-L	128
	V V-1SVUL	125			
	C C-1SVU	127			
Handle lock device	HL HLF-05SVU	134			
	HL-S HLS-05SVU				

Outline Drawing

Front connection

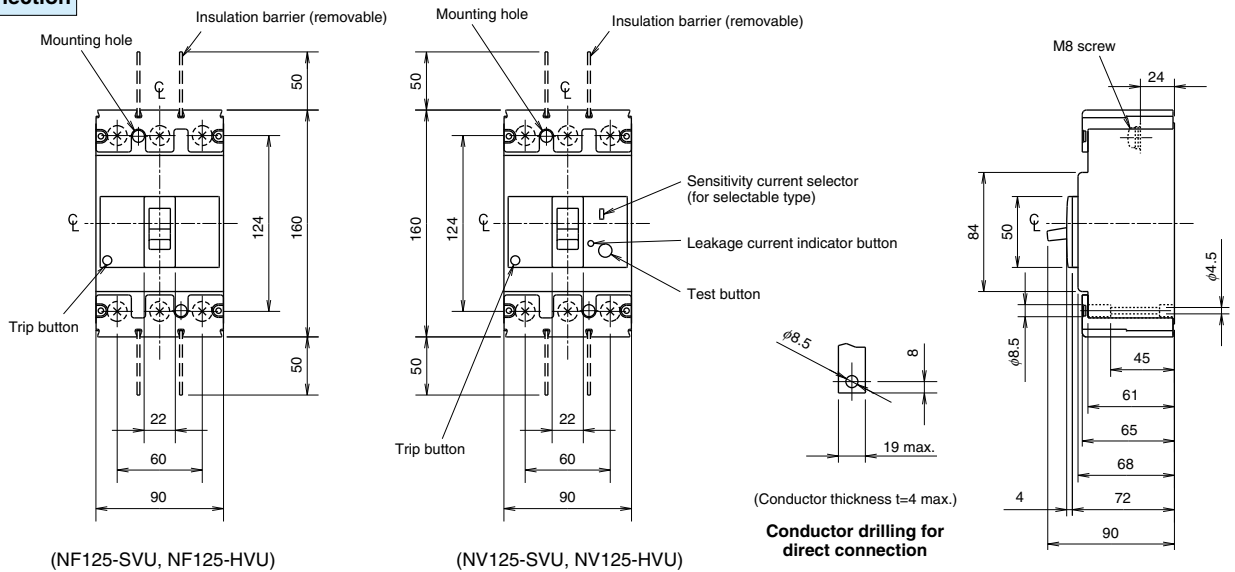

(NF125-SVU, NF125-HVU)

(NV125-SVU, NV125-HVU)

Conductor drilling for direct connection

Compatible crimp terminals Tightening torque 54lb-in (6N-m)

mm <sup>2</sup>	AWG (#) (60°C/75°C)	Crimp terminal type (*1)	
		JST	NTM
2.5-2.63	14	R2-8	R2-8
2.63-6.64	12-10	R5.5-8	R5.5-8
6.64-10.52	8	R8-8	R8-8
10.52-16.78	6	R14-8	R14-8 R14-8S
16.78-26.66	4	R22-8	R22-8S
26.66-42.42	2	38-S8	R38-8S
42.42-60.57	1/0	60-2BA 60-S8	CB60-8

JST: Japan Solderless Terminal Mfg. Co.

NTM: Nichifu Co., Ltd.

Note \*1 When using with a wire connection, use the crimp terminal combination shown above.

Front connection (solderless terminal)

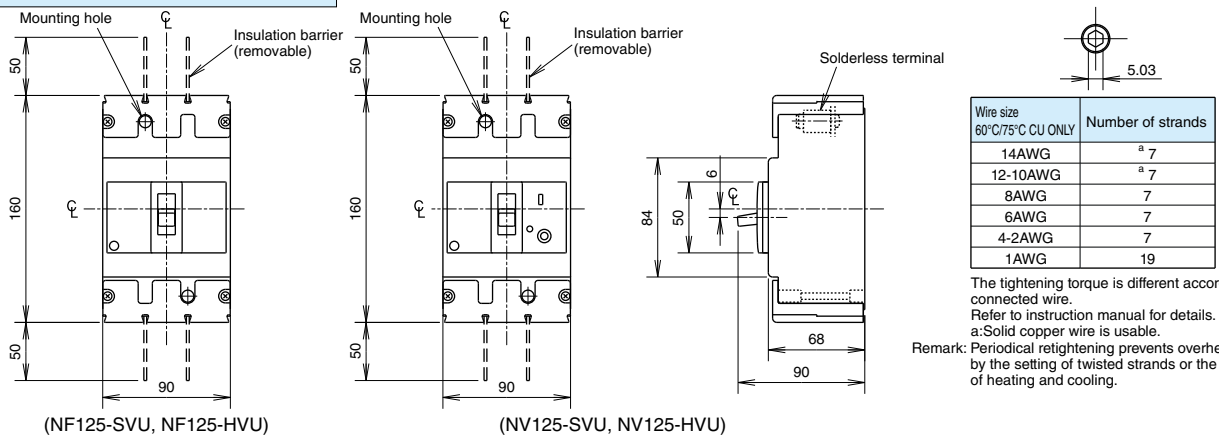

(NF125-SVU, NF125-HVU)

(NV125-SVU, NV125-HVU)

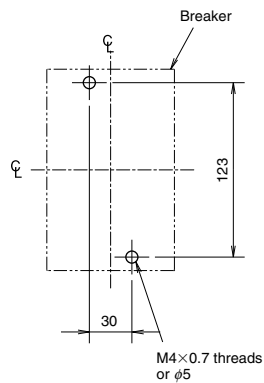

Drilling (Tapping)

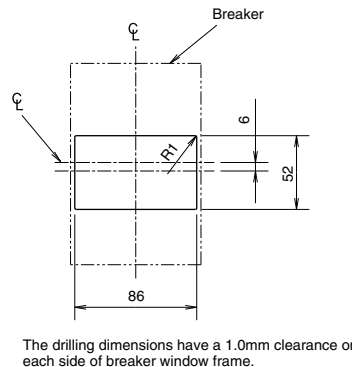

The drilling dimensions have a 1.0mm clearance on each side of breaker window frame.

Front-panel cutout

Remark: 1. 2-pole models are 3-pole with the central pole conductor removed.

NF250-CVU  
NF250-SVU  
NF250-HVU  
NV250-CVU  
NV250-SVU  
NV250-HVU



NF250-HVU

Model		NF250-CVU	NF250-SVU	NF250-HVU	Model		NV250-CVU	NV250-SVU	NV250-HVU
Rated current I <sub>n</sub> (A) Reference ambient temperature 40°C	125 150	125 150	125 150	125 150	Rated current I <sub>n</sub> (A) Reference ambient temperature 40°C	125 150	125 150	125 150	125 150
	175 200 225	175 200 225	175 200 225	175 200 225		175 200 225	175 200 225	175 200 225	175 200 225
Number of poles		3	3	3	Number of poles		3	3	3
Rated short-circuit breaking capacity (kA)	UL 489 CSA C22.2 No.5	240	240	480	480	600Y/347V	600Y/347V	600Y/347V	600Y/347V
	AC	600Y/347V	-	-	-	-	18	18	18
		480V	-	-	35	35	50	50	50
	240V	35	35	65	65	100	100	100	
IEC 60947-2 EN 60947-2 (kA/ics)	Rated insulation voltage U <sub>i</sub> V	690V	-	-	8/4	8/4	10/5	10/5	
		500V	10/8	10/8	25/13	25/13	36/18	36/18	
	440V	15/12	15/12	36/18	36/18	50/25	50/25		
	415V	25/19	25/19	36/18	36/18	50/25	50/25		
	400V	25/19	25/19	36/18	36/18	50/25	50/25		
	380V	25/19	25/19	36/18	36/18	50/25	50/25		
	230V	36/27	36/27	65/33	65/33	100/50	100/50		
Standard attached parts (Front connection)		Terminal screw M8 (Bolt (Hex-socket)) ×16 (3P: 6pcs) Mounting screw M4×0.7×55 (2 screws), Insulating barrier (4pcs)							

Note \*1 0.1 for UL1053.

## Operating Characteristics

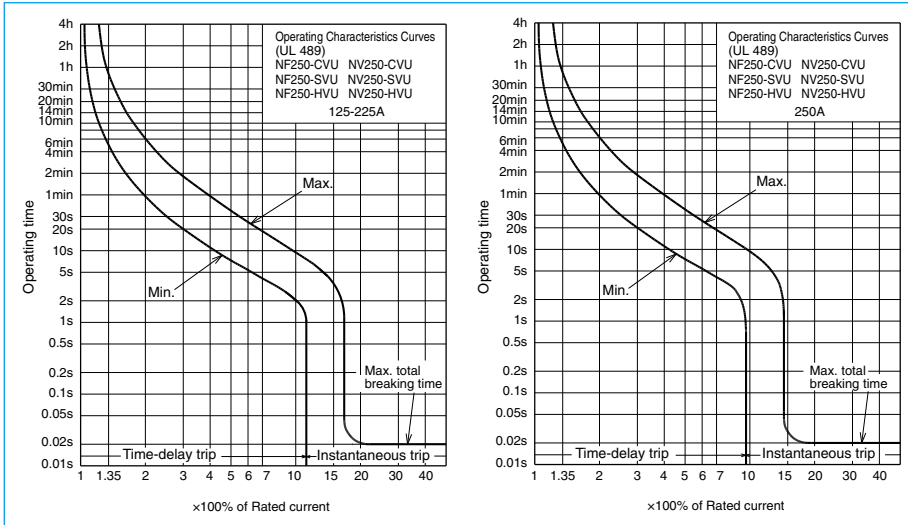

## Earth Leakage Tripping Characteristics

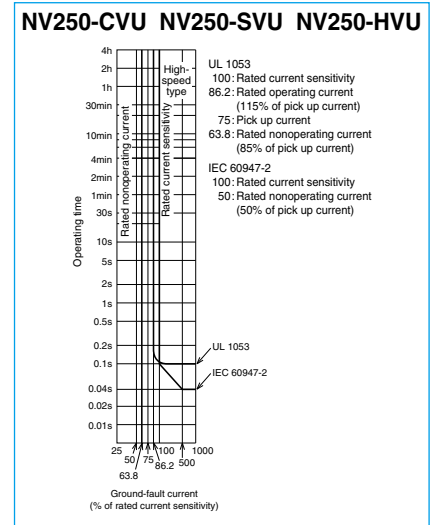

## Internal Accessories

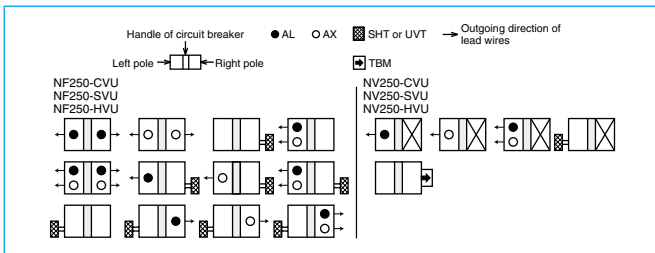

## Temperature Compensation Curve

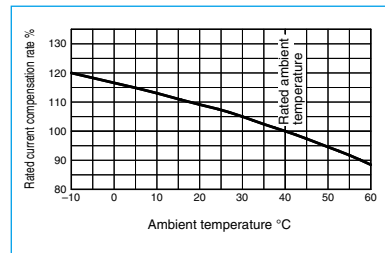

## Internal Wiring Diagram

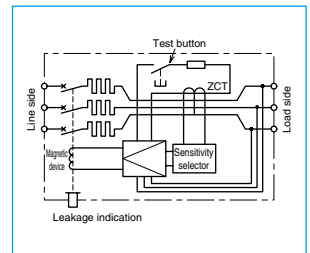

## External Accessories

Accessories	Type name	Reference page	Accessories	Type name	Reference page
Operating handle	F F-2SVUL	123	Terminal cover	Large TC-L	128
	V V-2SVUL	125			
	C C-2SVU	127			
Handle lock device	HL HLF-05SVU	134			
	HL-S HLS-2SVU				

Outline Drawing

Front connection

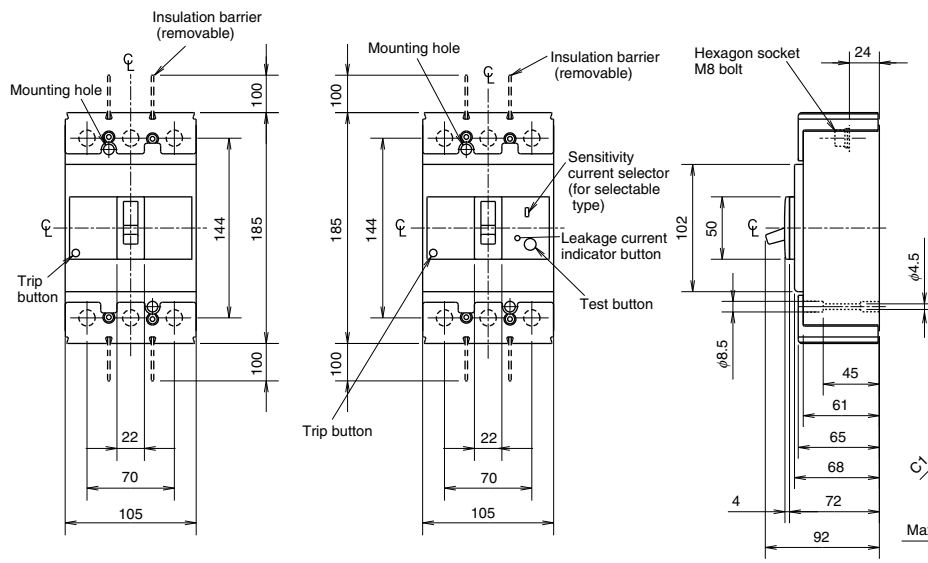

(NF250-CVU, NF250-SVU, NF250-HVU)

(NV250-CVU, NV250-SVU, NV250-HVU)

Compatible crimp terminals Tightening torque 90lb-in (10N.m)

Applicable wire range	AWG (#) (75°C)	Crimp terminal type (*2)	
mm <sup>2</sup>		JST	NTM
16.78-26.66	4	R22-8 22-S8	R22-8 R22-8S CB22-8S
26.66-42.42	2	R38-8 38-S8	R38-8 R38-8S
42.42-60.57	1/0	R60-8 60-2BA CB60-S8	R60-8 CB60-8 CB60-8S
60.57-76.28	2/0	70-8	R70-8
76.28-96.3	3/0	80-3BA CB80-S8	
96.3-117.2	4/0	100-3BA CB100-S8	
117.2-152.05	250/300kcmil	CB150-S8 (*1)	

JST: Japan Solderless Terminal Mfg. Co.  
 NTM: Nichifu Co., Ltd.  
 Notes \*1 TCL-2SVU3L can be mounted when using CB150-S8.  
 \*2 When using with a wire connection, use the crimp terminal combination shown above.

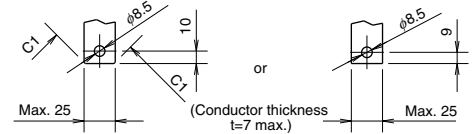

Conductor drilling for direct connection

Front connection (solderless terminal)

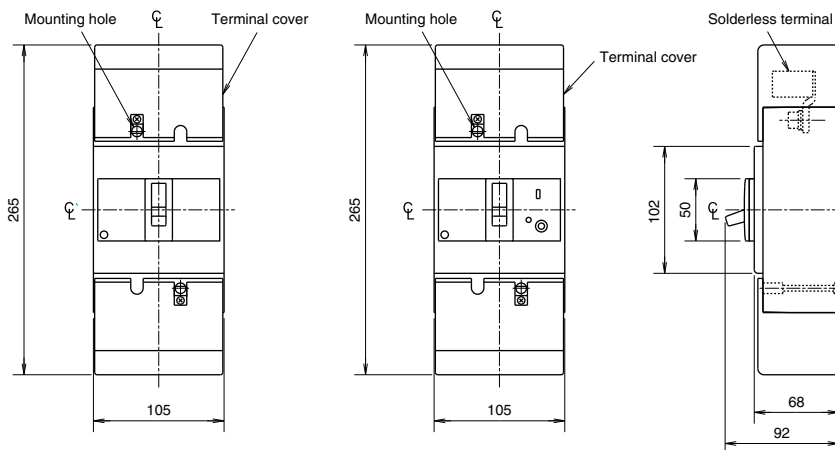

(NF250-CVU, NF250-SVU, NF250-HVU)

(NV250-CVU, NV250-SVU, NV250-HVU)

Wire size	Number of strands
75°C CU ONLY	
4-2AWG	7
1-1/0AWG	19
3/0-4/0AWG	19
250-350kcmil	37

The tightening torque is different according to connected wire. Refer to instruction manual for details.

Remark: Periodical retightening prevents overheating by the setting of twisted strands or the stress of heating and cooling.

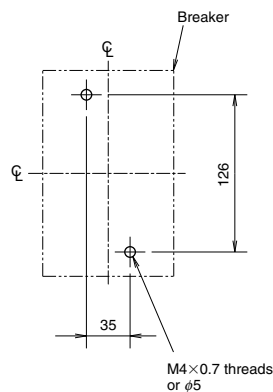

Drilling (Tapping)

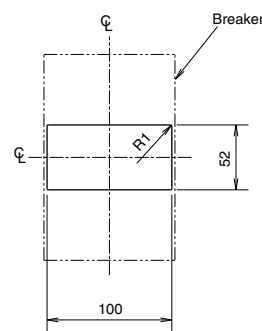

The drilling dimensions have a 1.0mm clearance on each side of breaker window frame.

Front-panel cutout

## NF400-SWU NF400-HWU



NF400-SWU

Model		NF400-SWU	NF400-HWU		
Rated current In (A)		250 300	250 300		
Reference ambient temperature 40°C		350 400	350 400		
Number of poles		3	3		
Rated short-circuit breaking capacities (kA)	UL 489	Rated voltage (VAC)			
		AC	600Y/347V	20	25
			480V	35	65
	240V		65	100	
	IEC 60947-2 EN 60947-2 (Icu/Ics)	Rated insulation voltage Ui (V)		690	690
		AC	690V	10/10(5/5) (*1)	15/10
			500V	30/30(25/25) (*1)	42/42
			440V	42/42(36/36) (*1)	65/65
			415V	45/45(36/36) (*1)	70/70
			400V	45/45(36/36) (*1)	70/70
380V			50/50(42/42) (*1)	70/70	
230V	85/85(65/65) (*1)		100/100		
Standard attached parts		Terminal screw: M12 bolt×35 (3-pole: 6pcs) Mounting screw: M6×60 (4screws) Insulating plate (1pc) Insulating barrier (4pcs) (Only for type with bar terminals)			

Note \*1 In case of solderless terminal, interrupting capacity reduces: (/).  
\*2 0.1 for UL1053.

### Operating Characteristics

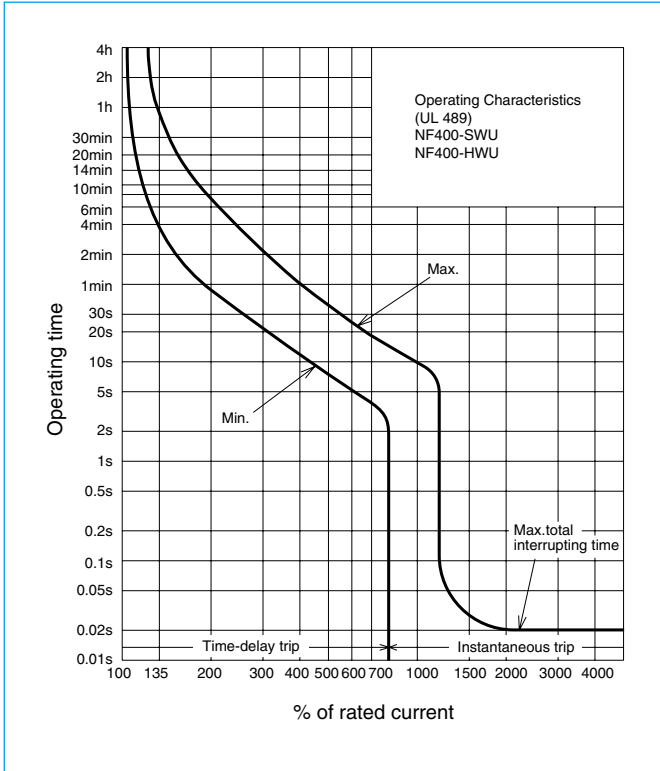

### Internal Accessories

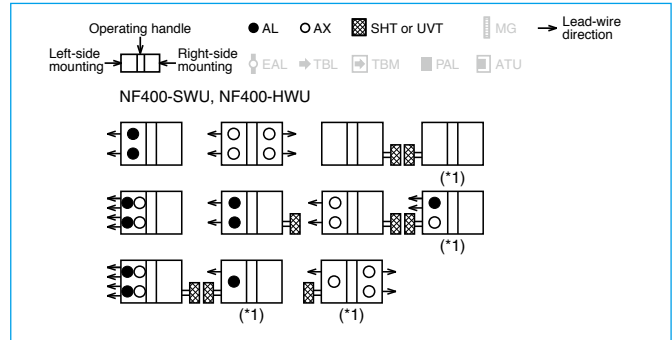

Note \*1 Right-side mounting is standard of SHT and UVT. Specify separately for left-side mounting.

### Temperature Compensation Curve

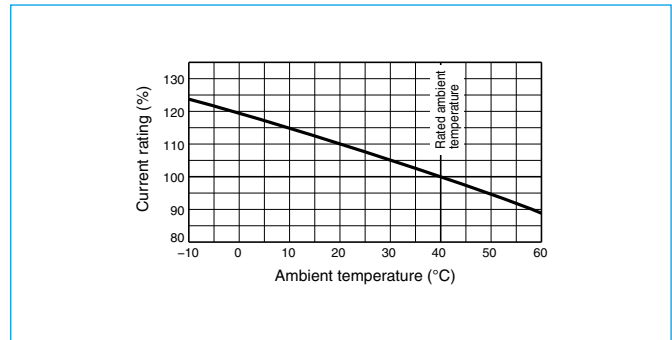

### External Accessories

Accessories	Type name	Reference page	Accessories	Type name	Reference page
Operating handle	F F-4SUL	123	Terminal cover	Large TC-L	128
	V V-4SUL	125			
	C C-4SWU	127			
Handle lock device	HL HL-4SWU	134			

Outline Drawing

**Front connection (Solderless terminal)**

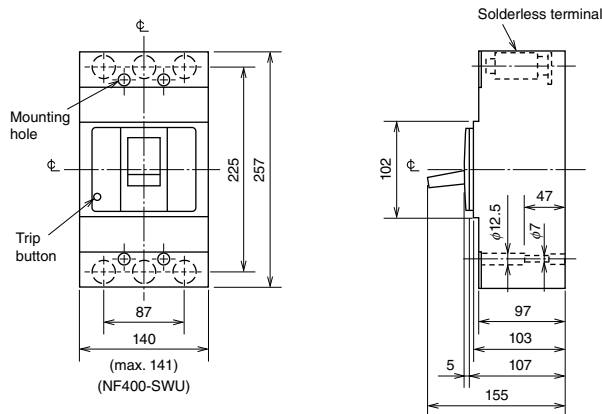

**Hexagon socket set screw**

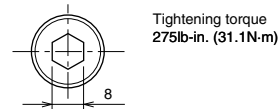

**UL**

Ampere ratings	Wire size	Number of strands
250A, 300A	250-350kcmil CU	37
250A	350kcmil AL	
350A, 400A	(2) 3/0AWG CU	19

**IEC**

Ampere ratings	Wire size (IEC 60228)	
	Class 2	Class 5
250A, 300A	70-185mm <sup>2</sup>	95-185mm <sup>2</sup>
350A, 400A	150-240mm <sup>2</sup>	150-185mm <sup>2</sup>

- Use a wire size that can carry the rated current.
- When using IEC Class 5 (multi-core wire), pay attention to strand breakage and pinching, etc., while tightening.
- The NF400-HWU does not have a solderless terminal.

- Remarks:
- Do not remove solderless terminal in any case.
  - When using the solderless terminals, conduct periodic inspections and tightening as the wires may wear down over use.

**Front connection (Busbar terminal)**

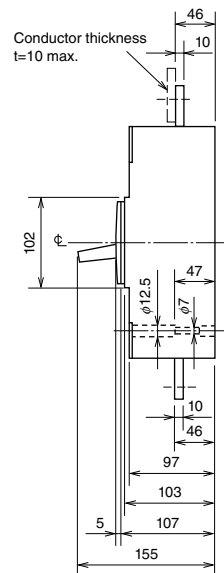
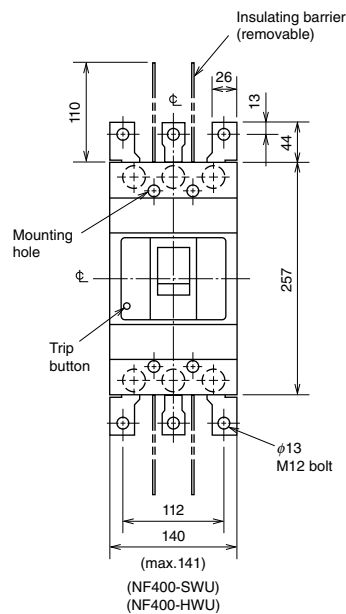

Remark: Do not remove busbar terminal in any case.

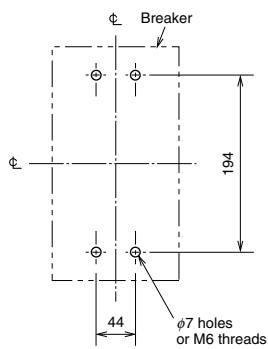

**Drilling (Tapping)**

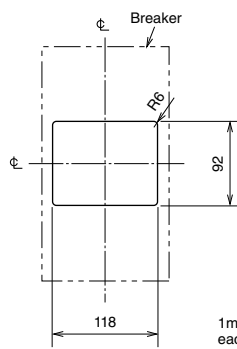

**Front-panel cutout**

1mm clearance on each side of handle.

Remarks: When mounted in steel or cast box cover must be insulated as shown. 58mm air gap to cover or 0.8mm fibre insulating plate extending 12.7mm out from each side of breaker.

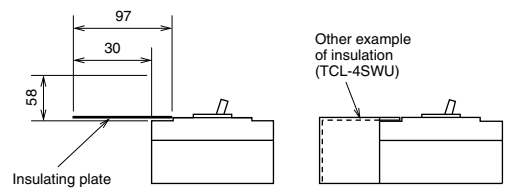

(Line)

## NF630-SWU NF630-HWU



Model		NF630-SWU	NF630-HWU		
Rated current In (A) Reference ambient temperature 40°C		500 600 630	500 600 630		
Number of poles		3	3		
Rated short-circuit breaking capacities (kA)	UL 489 CSA C22.2 No.5	Rated voltage (VAC) AC	600Y/347V	20	25
			480V	35	65
			240V	85	100
	IEC 60947-2 EN 60947-2 (Icu/Ics)	Rated insulation voltage Ui (V) AC	690V	10/10	15/10
			500V	30/30	42/42
			440V	42/42	65/65
			415V	45/45	70/70
			400V	45/45	70/70
			380V	50/50	70/70
			230V	85/85	100/100
Standard attached parts		Terminal screw: M12 bolt×40 (3-pole: 12pcs) Mounting screw: M6×35 (4pcs) Insulating plate (1 pce) Insulating barrier (500A,600A: 2pcs, 630A: 4pcs) (Only for type with bar terminals)			

### Operating Characteristics

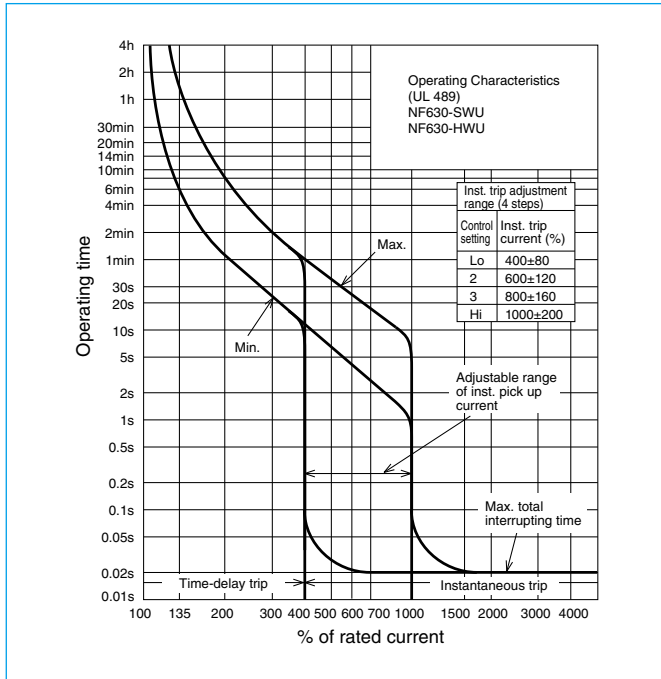

### Internal Accessories

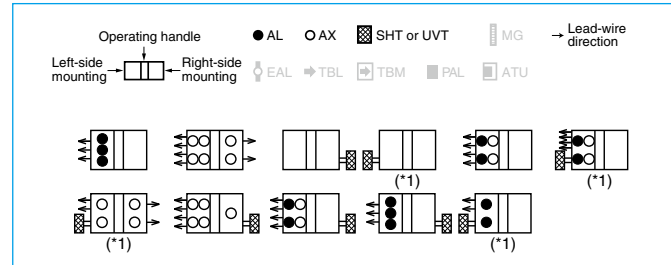

### Temperature Compensation Curve

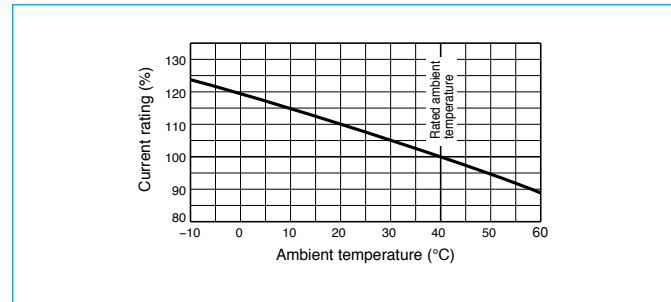

### External Accessories

Accessories	Type name	Reference page	Accessories	Type name	Reference page
Operating handle	F F-6SUL	123	Terminal cover	Large TC-L	128
	V V-6SUL	125			
Handle lock device	HL HL-4SWU	134			

Outline Drawing

**Front connection (Solderless terminal)**

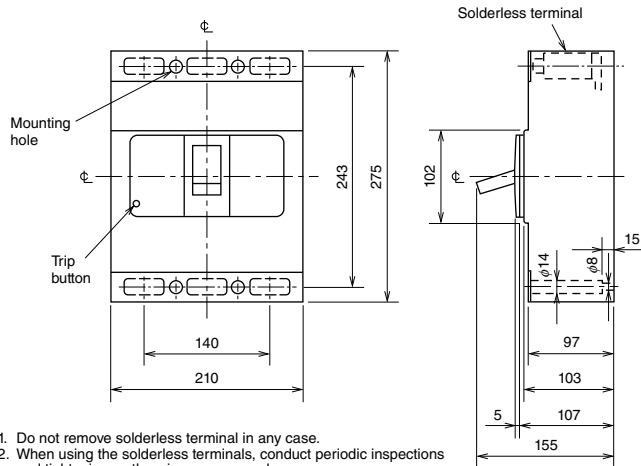

Remarks: 1. Do not remove solderless terminal in any case.  
 2. When using the solderless terminals, conduct periodic inspections and tightening as the wires may wear down over use.

**Hexagon socket set screw**

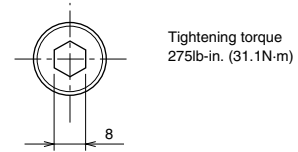

**UL**

Ampere ratings	Wire size	Number of strands
500A, 600A	(2) 250-350kcmil CU ONLY	37

**IEC**

Ampere ratings	Wire size (IEC 60228)	
	Class 2	Class 5
500A, 600A	(2) 95-185mm <sup>2</sup>	(2) 120-185mm <sup>2</sup>

- Use a wire size that can carry the rated current.
- When using IEC Class 5 (multi-core wire), pay attention to strand breakage and pinching, etc., while tightening.
- The 630A and NF630-HWU does not have a solderless terminal.

**Front connection (Busbar terminal)**

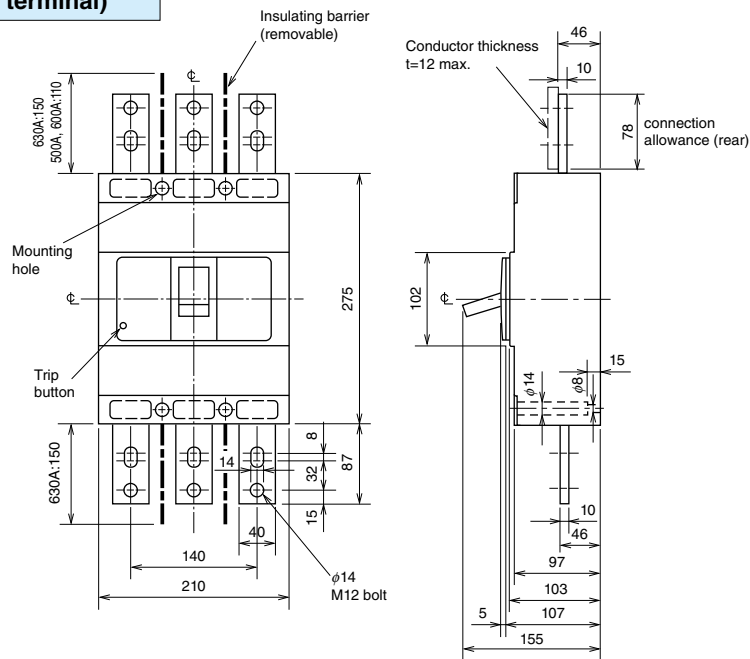

Remark: Do not remove busbar terminal in any case.

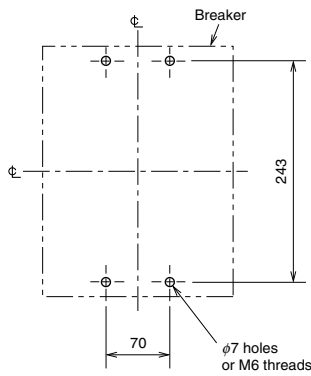

**Drilling (Tapping)**

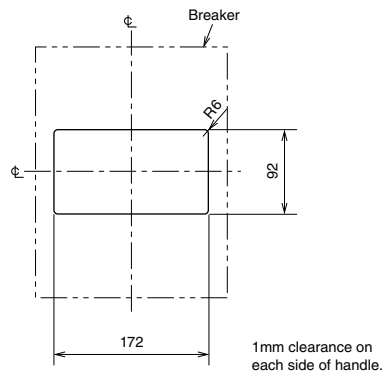

**Front-panel cutout**

Remarks: When mounted in steel or cast box cover must be insulated as shown.  
 58mm air gap to cover or 0.8mm fibre insulating plate extending 12.7mm out from each side of breaker.

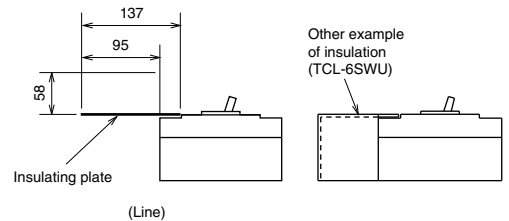

## NF30-FAU NF50-FAU NV30-FAU NV50-FAU



NF30-FAU



NV30-FAU

### Earth Leakage Tripping Characteristics

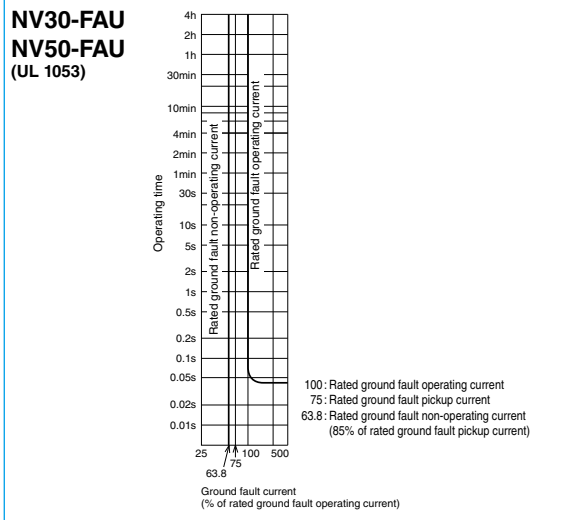

Model				NF30-FAU		NF50-FAU	
Rated current In (A) Reference ambient temperature 40°C				5 10 15 20 30		5 10 15 20 30 40 50	
Number of poles				2 3		2 3	
Rated short-circuit breaking capacities (kA)	UL 1077 CSA 22.2 No.235	AC	240V	2.5 (*1)			
		DC	60V	1.5			
	IEC 60947-2 EN 60947-2 (Icu/Ics)	Rated insulation voltage Ui (V)		250			
		AC	230V	2.5/1 (*2)			
DC	60V	1.5/1					
Standard attached parts				IEC35 rail mounting claws			

Notes \*1 Rated short-circuit breaking capacity of rated current 5A is 1.5kA.  
\*2 Rated short-circuit breaking capacity of rated current 5A is 1.5/1kA.

Model				NV30-FAU		NV50-FAU	
Rated current In (A) Reference ambient temperature 40°C				5 10 15 20 30		5 10 15 20 30 40 50	
Number of poles				2 3		2 3	
Phase line				1φ2W 3φ3W 1φ2W		1φ2W 3φ3W 1φ2W	
Rated current sensitivity (mA)				30			
Pick-up current sensitivity UL 1053				75% of Δn			
Operating time (sec) within at 5IΔn				0.04 (at 5IΔn)			
Earth leakage protection characteristic				Type AC			
Earth leakage indication system				Mechanical type (button)			
Rated short-circuit breaking capacities (kA)	UL 1077 CSA 22.2 No.235	AC	240V	2.5 (*1)			
		AC	230V	2.5/1 (*2)			
Standard attached parts				IEC35 rail mounting claws			

Notes \*1 Rated short-circuit breaking capacity of rated current 5A is 1.5kA.  
\*2 Rated short-circuit breaking capacity of rated current 5A is 1.5/1kA.

### Operating Characteristics

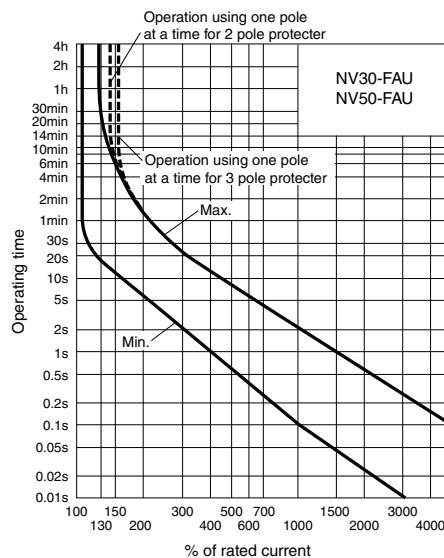
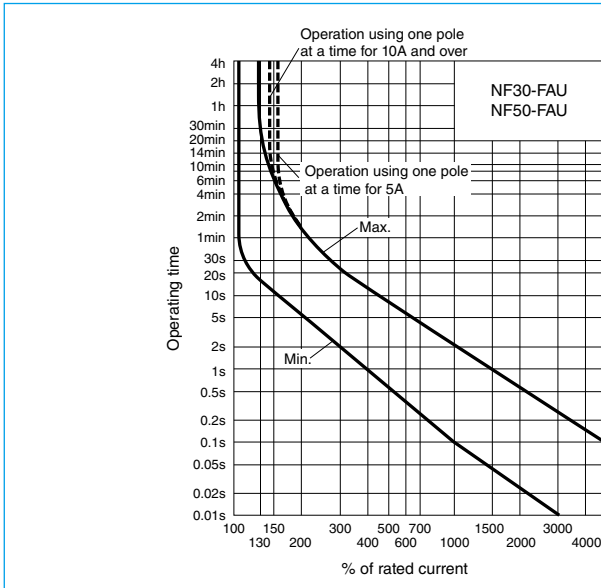

### Internal Accessories

Type	NF30-FAU, NF50-FAU		NV30-FAU, NV50-FAU	
	2P	3P	2P	3P
AL				
AX				
AL+AX				
SHT				
AL+SHT				

Left-side mounting      Right-side mounting

● AL    ○ AX  
 SHT or UVT  
 MG    EAL    TBL  
 TBM    PAL    ATU  
 Lead-wire direction

### Temperature Compensation Curve

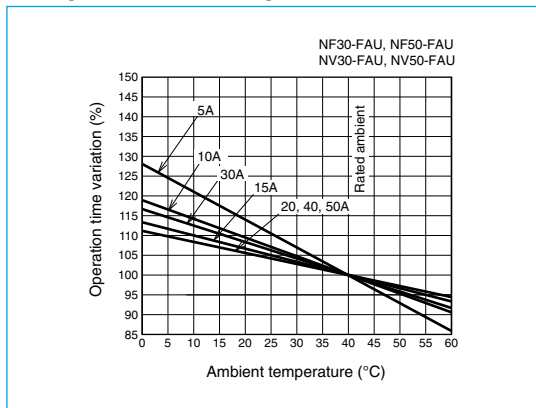

### External Accessories

Accessories	Small	Type name	Reference page
Terminal cover	TC-S	TCS-05FA2	128
		TCS-05FA3	
	RTC	RTC-05FA2	
		RTC-05FA3	
Lock cover	LC (*1)	LC05FA	135
Handle lock device	HL (*1)	HL-05FA	134

Note \*1 It is recognition of UL (cURus), CSA.  
 It is not recognition of CCC, TUV, UKCA.

### Outline Drawing

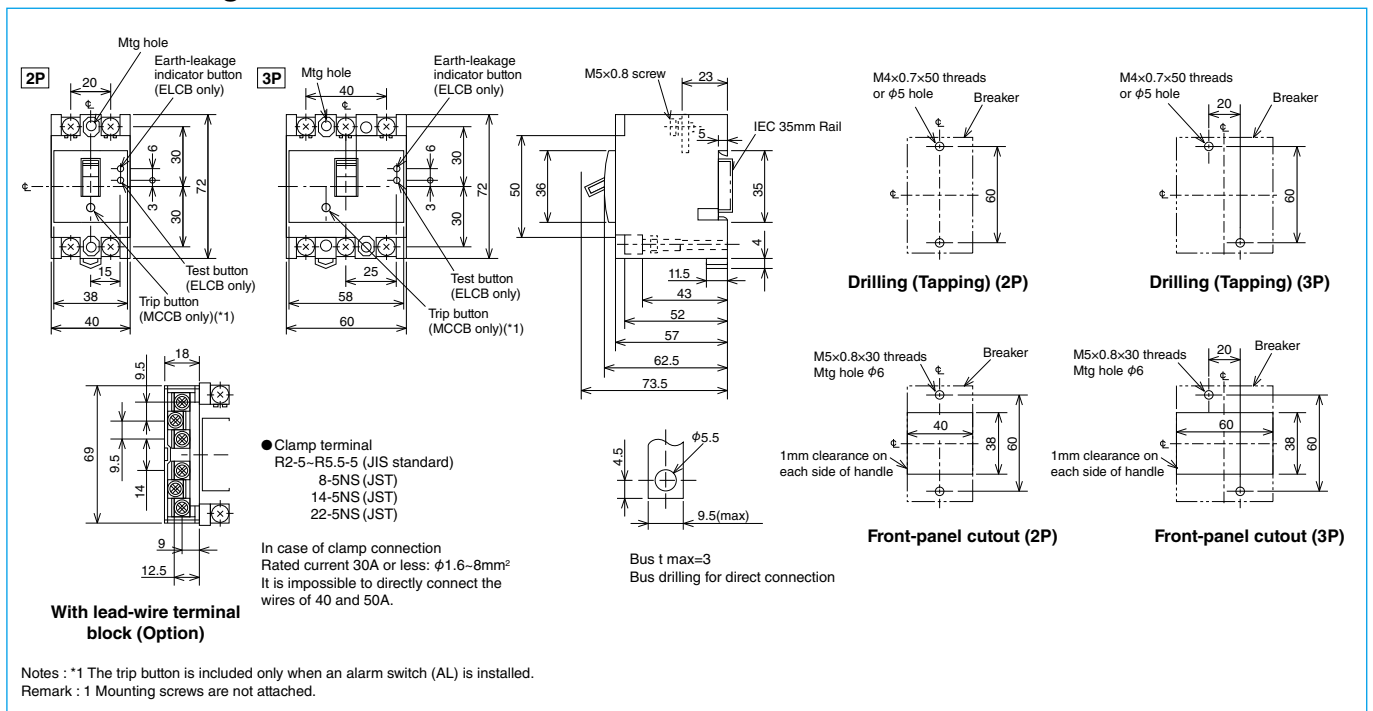

## NF50-FHU NF100-FHU NV50-FHU NV100-FHU



NF100-FHU



NV100-FHU

Model				NF50-FHU		NF100-FHU	
Rated current In (A) Reference ambient temperature 40°C				3 5 10 15 20 30 40 50		60 75 100	
Number of poles				2		3	
Rated short-circuit breaking capacities (kA)	UL 1077 CSA 22.2 No.235	AC	240V	5		5	
	IEC 60947-2 EN 60947-2 (Icu/Ics)	AC	Rated insulation voltage Ui (V) 400V 230V	500		1.5/1 5/2	
Standard attached parts				IEC35 rail mounting claws			

Model				NV50-FHU		NV100-FHU	
Rated current In (A) Reference ambient temperature 40°C				5 10 15 20 30 40 50		60 75 100	
Number of poles				2		3	
Phase line				1φ2W		3φ3W 1φ2W 1φ3W	
Rated current sensitivity (mA)				30 50 100			
Pick-up current sensitivity UL 1053				75% of IΔn			
Operating time (sec) within at 5IΔn				0.04 (at 5IΔn)			
Earth leakage protection characteristic				Type AC			
Earth leakage indication system				Mechanical type (button)			
Rated short-circuit breaking capacities (kA)	UL 1077 CSA 22.2 No.235	AC	240V	5			
	IEC 60947-2 EN 60947-2 (Icu/Ics)	AC	230V	5/2			
Standard attached parts				IEC35 rail mounting claws			

### Operating Characteristics

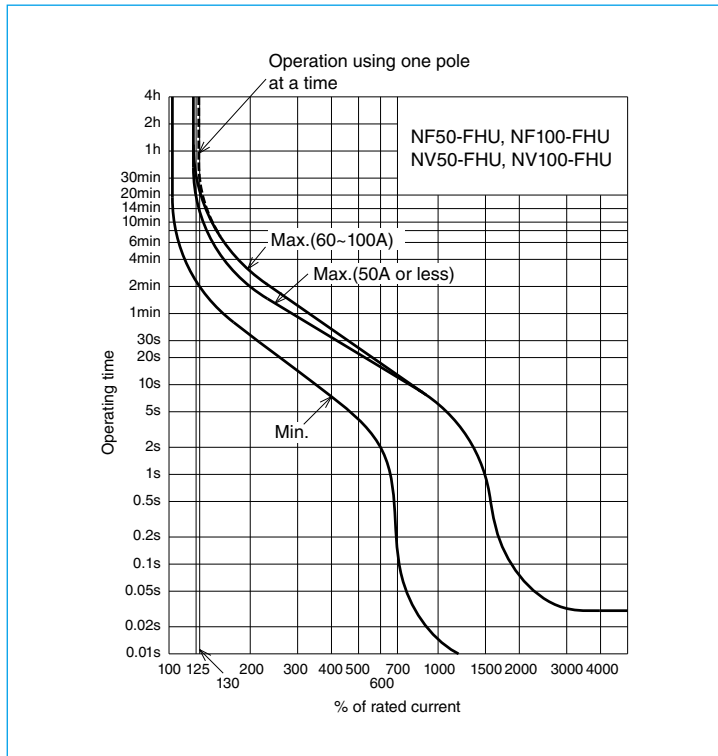

### Earth Leakage Tripping Characteristics

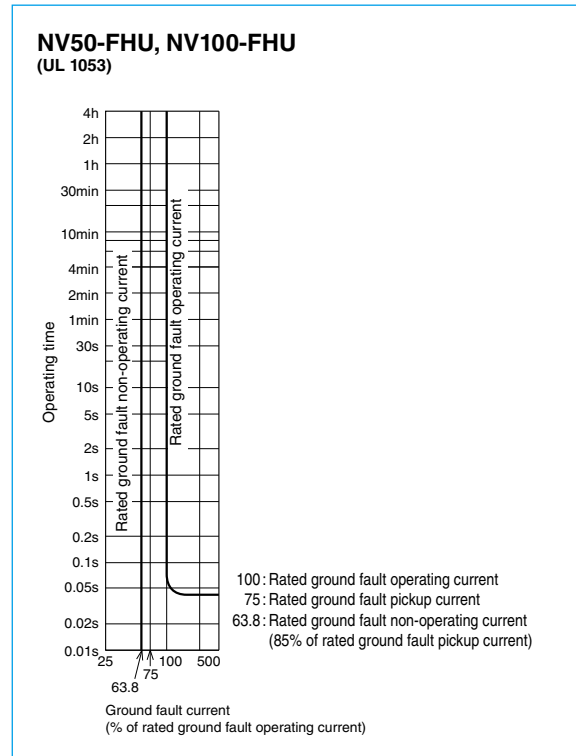

Outline Drawing

Internal Accessories

Type	NF50-FHU (*1)			NF100-FHU (*2)		
	Number of poles			Number of poles		
Accessories	2P	3P		2P	3P	
AL						
AX						
AL+AX						
SHT						
AL+SHT						

Note \*1 Lead wires are normally extended laterally.  
 Grooves are provided standard on the face of the breaker, allowing the extension of the lead wires along them.  
 \*2 Lead wires are usually extended load side.

Temperature Characteristic Curve

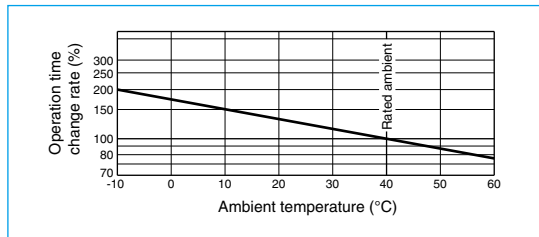

External Accessories

Accessories	Type name	Reference page
Terminal cover	Small TC-S	TCS-05FH2
		TCS-05FH3
		TCS-1FH3
	Large TC-L (*1)	TCL-05FH2
		TCL-05FH3
Lock cover	LC (*1)	LC03CS
Handle lock device	HL (*1)	HL-05FH

Note \*1 Not acquire UL (cURus), CCC, TÜV, UKCA.

Outline Drawing

Notes: \*1 Alarm switch installed

NF50-FHU NV50-FHU

NF100-FHU NV100-FHU

### NF250-SEV with MDU NF250-HEV with MDU



NF250-SEV with MDU (Breaker mounting)    NF250-HEV with MDU (External mounting)

Model		NF250-SEV with MDU	NF250-HEV with MDU		
Rated current I <sub>n</sub> (A) Reference ambient temperature 40°C		Adjustable 125-250 (12.5A step)			
Number of poles		3      4	3      4		
Rated insulation voltage U <sub>i</sub> (V)		690			
Rated short-circuit breaking capacity (kA)	IEC 60947-2 EN 60947-2 (Icu/Ics)	AC	690V	8/8	10/8
			500V	18/18	30/23
			440V	36/36	50/50
			415V	36/36	70/70
			400V	36/36	75/75
			380V	36/36	75/75
			230V	85/85	100/100
Standard attached parts (Front connection)		Mounting screw M4 × 0.7 × 55 (3P: 2pcs, 4P: 4pcs) Insulation barrier (3P: 4pcs, 4P: 6pcs)			
MDU accessories	External mounting	MDU, Mounting plate, Mounting plate screw, MDU mounting screw			
	Breaker mounting	MDU, Connection cable (for breaker mounting)			
	Panel mounting	MDU, Panel mounting bracket, Panel mounting screw, Connection cable (for panel mounting)			

### Operating Characteristics

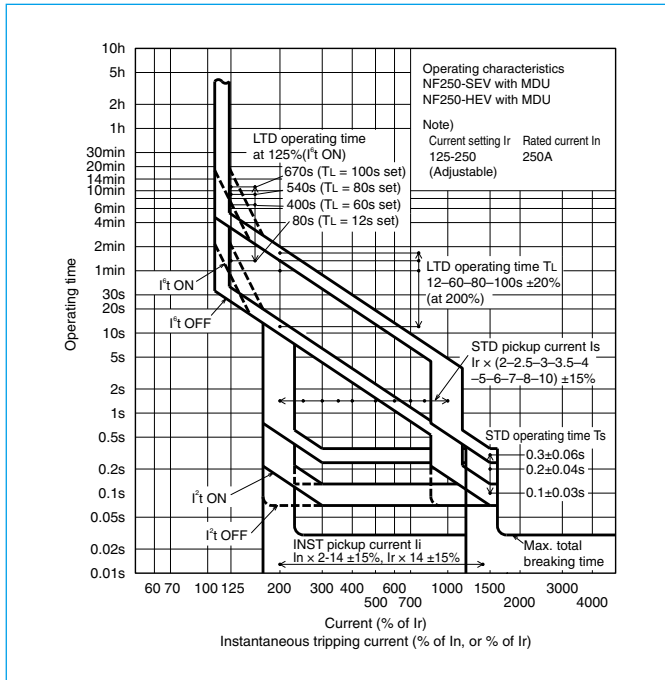

### Current Reducing Curve

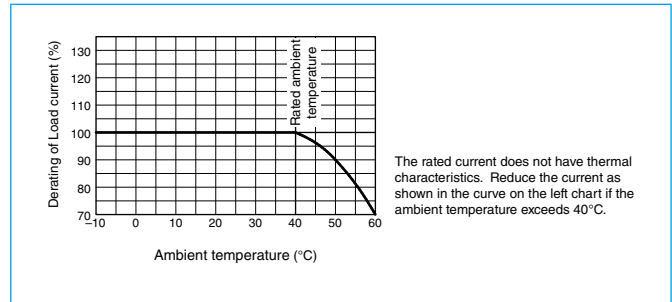

### Internal Accessories

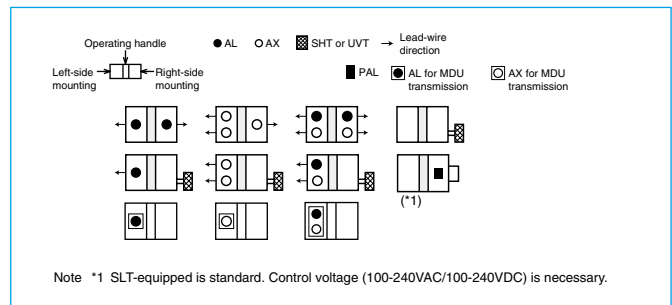

### External Accessories

Accessories	Type name	Reference page	Accessories	Type name	Reference page
Operating handle (*1)	F	F-2SV	Mechanical interlock	MI	3P MI-05SV3
	V	V-2SV		4P MI-2SV4	136
Handle lock device	LC	LC-05SV	Terminal cover	Small	3P TCS-2SV3 (*4)
	HL (*2)	HLF-05SV			4P TCS-2SV4
	HL-S (*1)	HLN-05SV		3P TCL-2SV3 (*4)	
		HLS-2SV		4P TCL-2SV3L (*4)	
Electrical operation device (*1)	TTC	TTC	3P TTC-2SV3 (*4)	140	
			4P TTC-2SV4		
			3P BTC-2SV3 (*4)		
			4P BTC-2SV4		

Notes \*1 Available only for the MDU panel mounting type.  
\*2 HLF types are used for OFF lock and HLN types for ON lock.  
\*3 Specify the working voltage.  
\*4 In the case of the MDU breaker mounting type, specify the model name with MP at the end.

Outline Drawing

Front connection

MDU external mounting

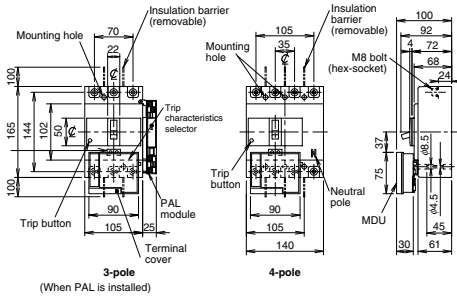

MDU breaker mounting

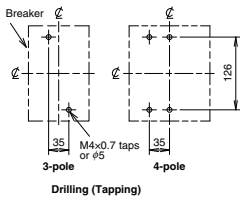
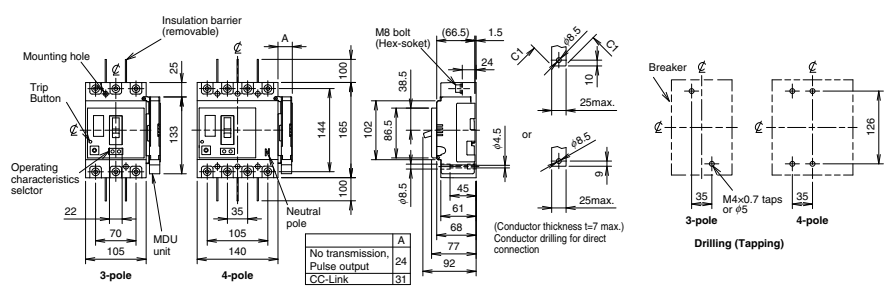

Rear connection

MDU external mounting

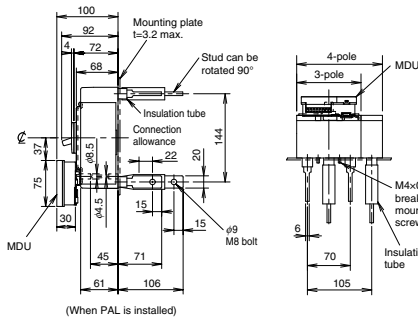

MDU breaker mounting

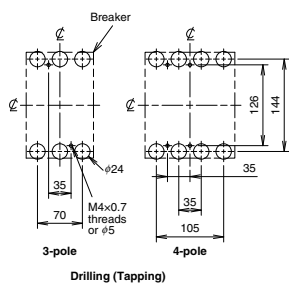
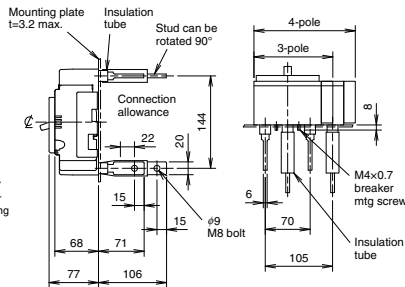

Front-panel cutout

MDU breaker mounting

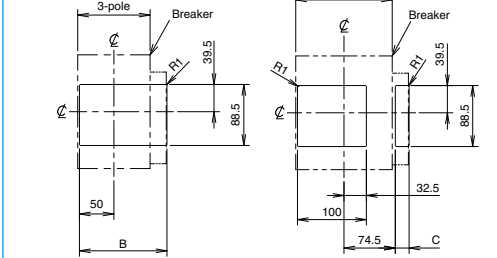

MDU specification	B	C
No transmission, Pulse output	127	20
CC-Link	134	27

1.0mm clearance on each side of handle frame

MDU external mounting

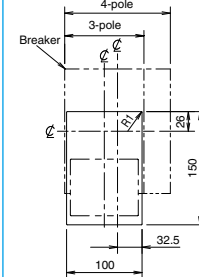

MDU panel mounting

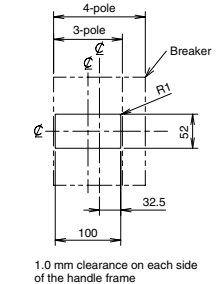

1.0 mm clearance on each side of the handle frame

### NF400-SEW with MDU NF400-HEW with MDU

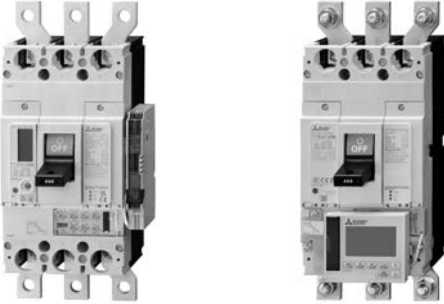

NF400-SEW with MDU  
(Breaker mounting)

NF400-HEW with MDU  
(External mounting)

Model		NF400-SEW with MDU	NF400-HEW with MDU	
Rated current In (A) Reference ambient temperature 40°C		Adjustable 200 225 250 300 350 400		
Number of poles		3	4	
Rated operational voltage Ue V		690		
Rated short-circuit breaking capacity (kA)	IEC 60947-2 EN 60947-2 (Icu/Ics)	AC	690V	10/10
			500V	30/30
			440V	42/42
			415V	50/50
			400V	50/50
			380V	50/50
			230V	85/85
			200V	85/85
Standard attached parts (Front connection)		Breaker	Mounting screw M6 × 60 (4pcs) Insulation barrier (3P: 4pcs, 4P: 6pcs)	
MDU accessories		External mounting	MDU, Mounting plate, Mounting plate screw, Connection cable, MDU mounting screw	
		Breaker mounting	MDU, Connection cable (for breaker mounting)	
		Panel mounting	MDU, Panel mounting bracket, Panel mounting screw, Connection cable (for panel mounting)	

### Operating Characteristics

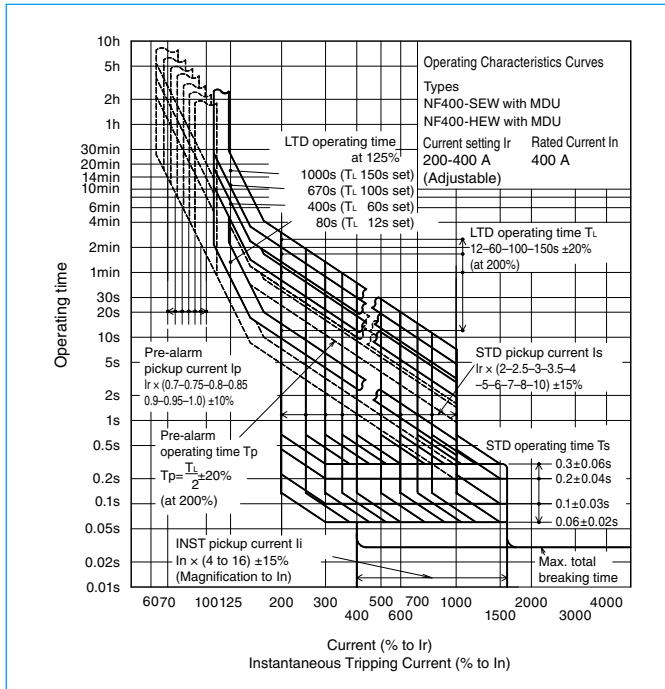

### Internal Accessories

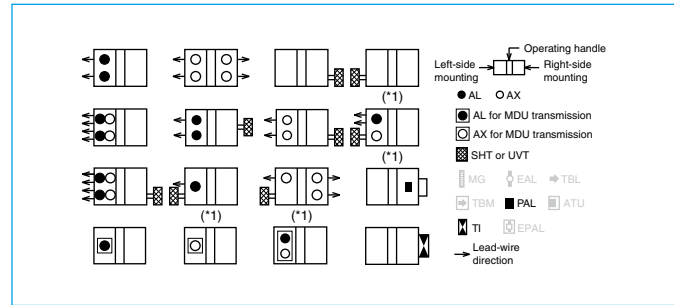

Note \*1 Right side mounting is standard of SHT and UVT. Specify separately for left side mounting.

### Current Reducing Curve

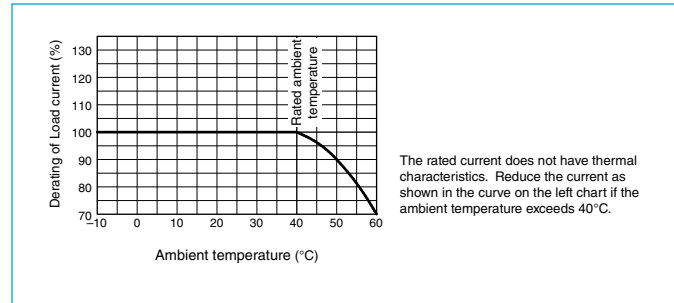

### External Accessories

Accessories	Type name		Reference page	Accessories	Type name		Reference page		
	Breaker mounting	Panel mounting			Breaker mounting	Panel mounting			
Operating handle	F	-	F-4S	Large	TC-L	3P	-	TCL-4SW3 (*1)	128
	V	-	V-4S			4P	-	TCL-4SW4 (*1)	
Handle lock device	HL	HL-4SW	HL-4SW	Skeleton	TTC	3P	TTC-4SW3-MDUB	TTC-4SW3	
	HL-S	-	HLS-4SW			4P	TTC-4SW4-MDUB	TTC-4SW4	
Mechanical interlock	MI	3P	MI-4SW3	Rear	BTC	3P	BTC-4SW3 (*1)	BTC-4SW3 (*3)	
		4P	MI-4SW4			Only line side	BTC-4SW4		
Auxiliary handle	HT	HT-4SW	HT-4SW	Electrical operation device	NFM	3P	-	(*2)	140
						4P			

Notes \*1 For NF400SEW with MDU.

\*2 Specify the operation method and voltage. Order in combination with the breaker unit.

\*3 This is for NF400-SEW with MDU. For rear terminal cover of NF400-HEW with MDU, use PTC-4SW3.

Outline Drawing

Front connection

MDU external mounting

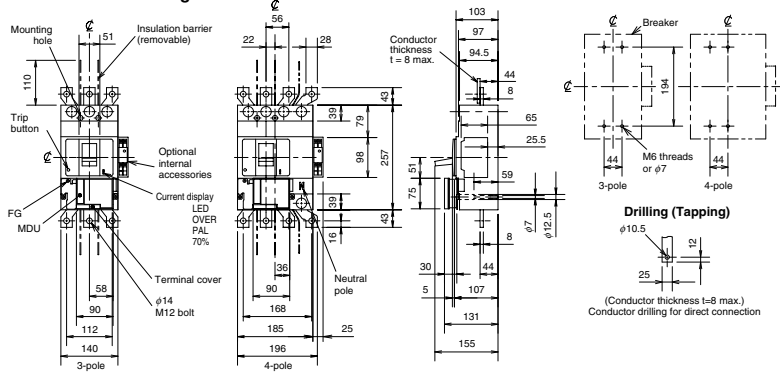

MDU breaker mounting

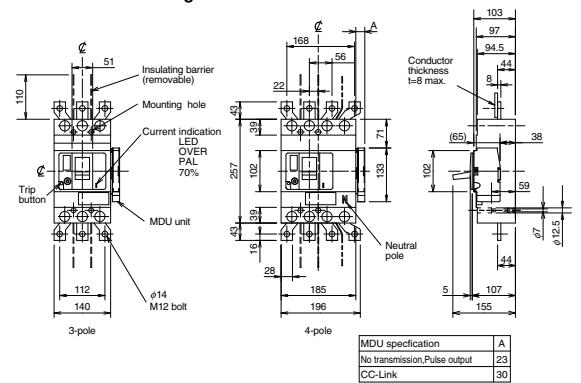

Rear connection

MDU external mounting

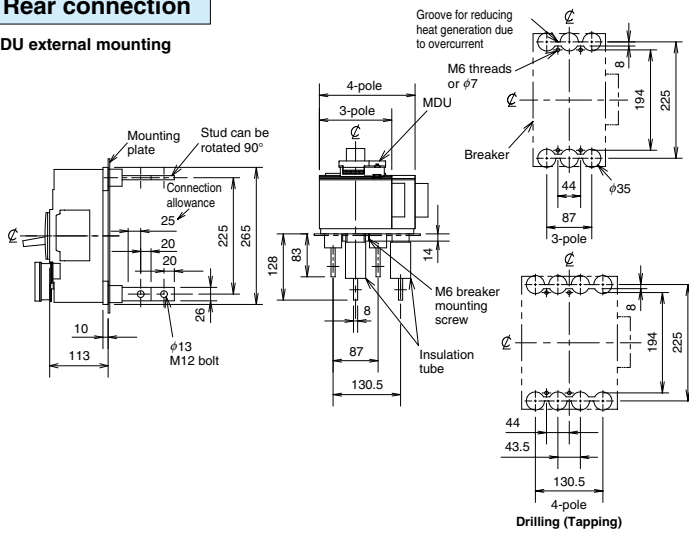

MDU breaker mounting

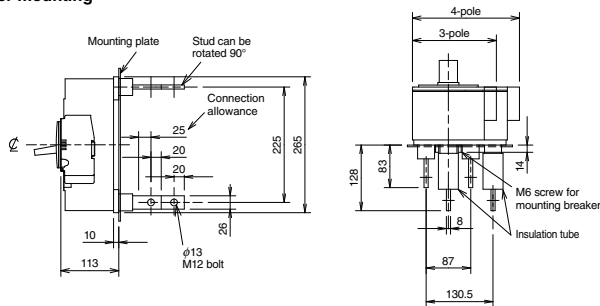

Note: When the insulating barrier for rear connection is used, mounting holes are added.

Front-panel cutout

MDU external mounting

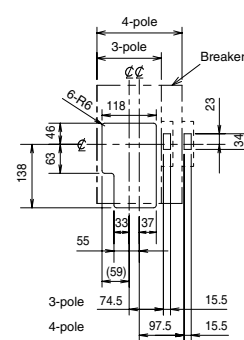

MDU panel mounting

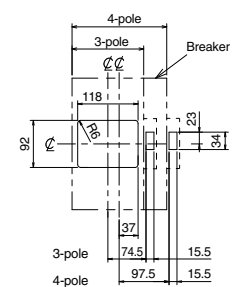

MDU breaker mounting

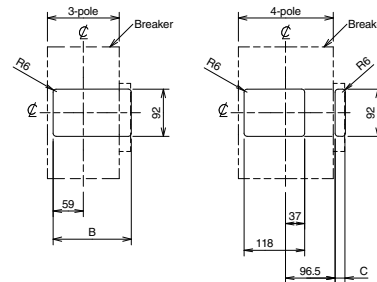

MDU specification	B	C
No transmission, Pulse output	153	20
CC-Link	160	27

## NF800-SEW with MDU NF800-HEW with MDU



NF800-SEW with MDU  
(Breaker mounting)



NF800-SEW with MDU  
(External mounting)

Model		NF800-SEW with MDU		NF800-HEW with MDU		NF800-SEW with MDU		NF800-HEW with MDU	
Rated current In (A) Reference ambient temperature 40°C		Adjustable 300 350 400 500 600 630				Adjustable 400 450 500 600 700 800			
Number of poles		3	4	3	4	3	4	3	4
Rated operational voltage Ue V		690		690		690		690	
Rated short-circuit breaking capacity (kA)	IEC 60947-2 EN 60947-2 (Icu/Ics)	AC	690V	10/10	15/15	10/10	15/15		
			500V	30/30	50/50	30/30	50/50		
			440V	42/42	65/65	42/42	65/65		
			415V	50/50	70/70	50/50	70/70		
			400V	50/50	70/70	50/50	70/70		
			380V	50/50	70/70	50/50	70/70		
			230V	85/85	100/100	85/85	100/100		
			200V	85/85	100/100	85/85	100/100		
Standard attached parts (Front connection) (*1)		Breaker		Mounting screw M6 × 35 (4pcs) Insulation barrier (3P: 2pcs, 4P: 3pcs)					
MDU accessories		External mounting		MDU, Mounting plate, Mounting plate screw, Connection cable, MDU mounting screw					
		Breaker mounting		MDU, Breaker mounting plate, Mounting screw for breaker mounting plate, Connection cable (for breaker mounting), MDU Mounting screw					
		Panel mounting		MDU, Panel mounting bracket, Panel mounting nut, Connection cable (for panel mounting), MDU Mounting screw					

Note \*1 4-pole models are provided with auxiliary handle.

## Operating Characteristics

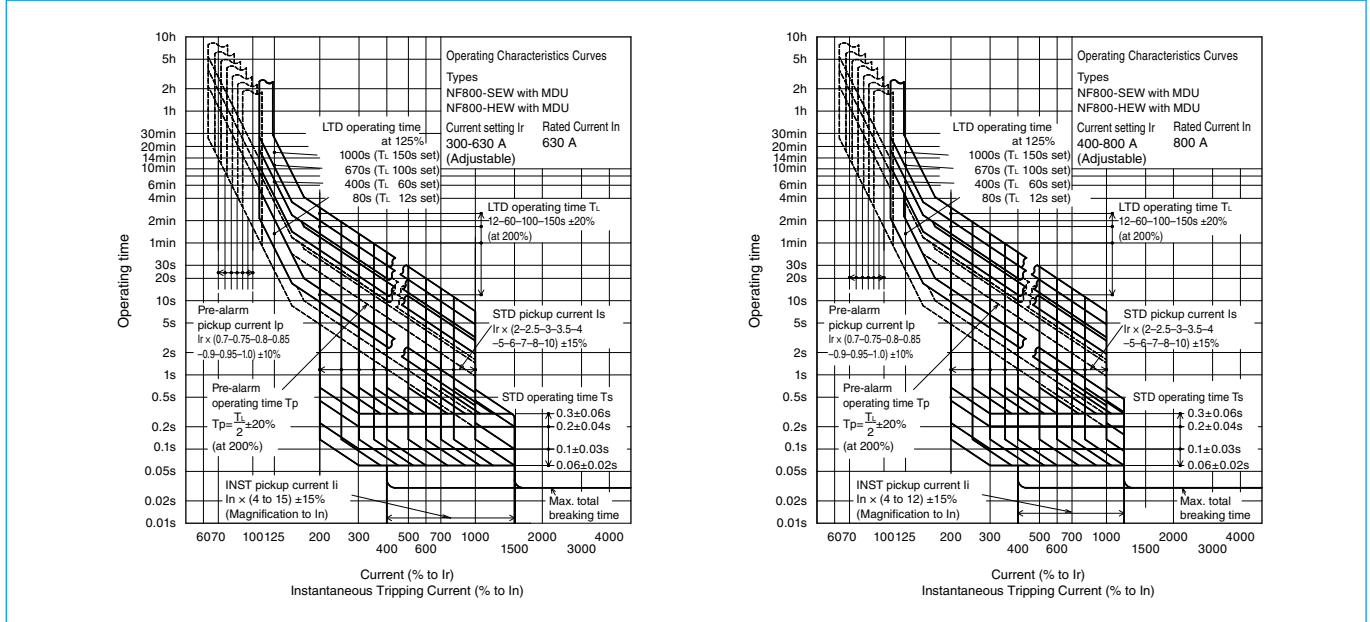

## Internal Accessories

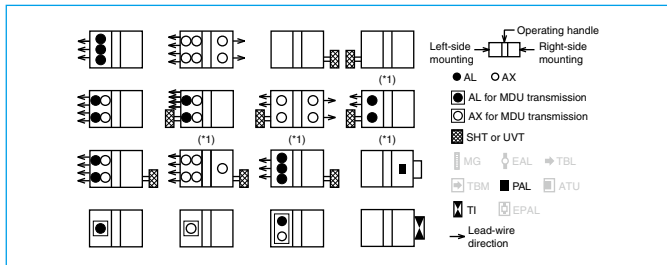

Note \*1 Right side mounting is standard of SHT and UVT. Specify separately for left side mounting.

## Current Reducing Curve

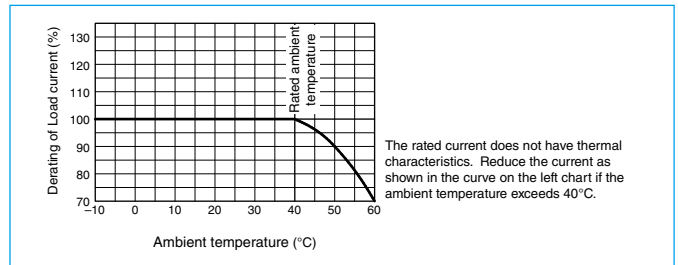

## External Accessories

Accessories	Type name		Reference page	Accessories	Type name		Reference page				
	Breaker mounting	Panel mounting			Breaker mounting	Panel mounting					
Operating handle	F	-	F-8S	123	Terminal cover	Large	TC-L	3P	-	TCL-8SW3	128
	V	-	V-8S	125			4P	-	TCL-8SW4		
Handle lock device	HL	HL-4SW	HL-4SW	134		Skeleton	TTC	3P	TTC-8SW3-MDUB	TTC-8SW3	
	HLS	-	HLS-8SW					4P	TTC-8SW4-MDUB	TTC-8SW4	
Mechanical interlock	MI	3P	MI-8SW3	MI-8SW3	Rear	BTC	3P	BTC-8SW3 Only line side	BTC-8SW3		
		4P	MI-8SW4	MI-8SW4			4P	BTC-8SW4 Only line side	BTC-8SW4		
Auxiliary handle	HT	HT-4SW	HT-4SW	135	Electrical operation device	NFM	3P	-	(*1)	140	
							4P	-	(*1)		

Note \*1 Specify the operation method and voltage. Order in combination with the breaker unit.

Outline Drawing

Front connection

MDU external mounting

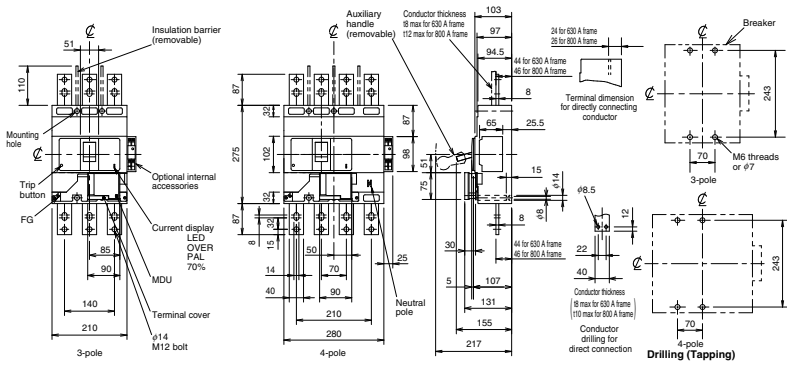

MDU breaker mounting

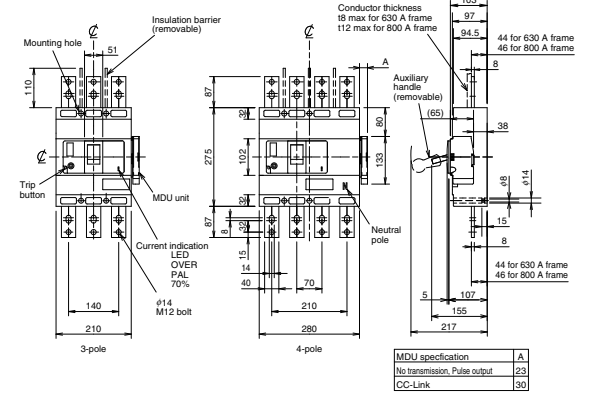

MDU specification	A
No transmission, Pulse output	23
CC-Link	30

Rear connection

MDU external mounting

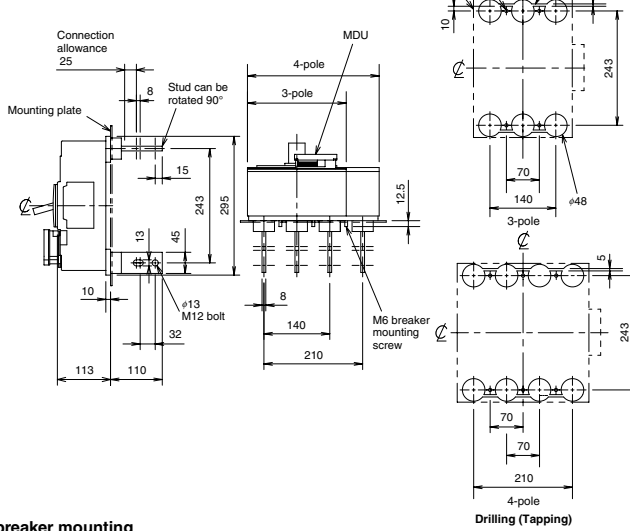

MDU breaker mounting

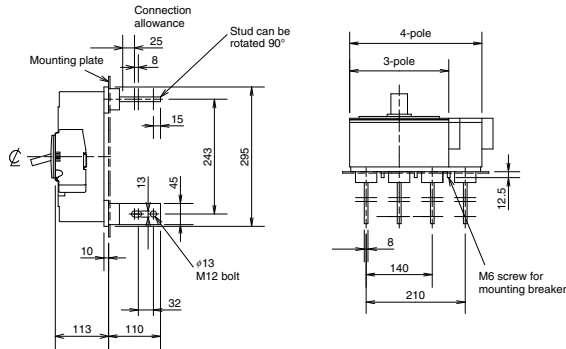

Note: When the insulating barrier for rear connection is used, mounting holes are added.

Front-panel cutout

MDU external mounting

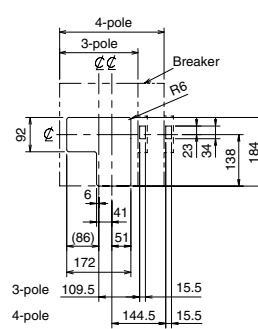

MDU panel mounting

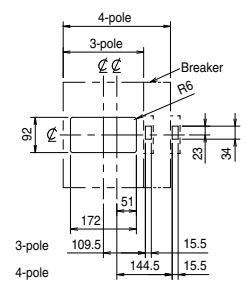

MDU breaker mounting

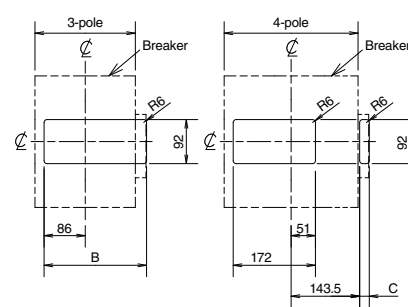

MDU specification	B	C
No transmission, Pulse output	215	20
CC-Link	222	27

### MDU-BN (No transmission), MDU-BP (Pulse output)

#### Panel mounting

When installing, ensure a distance larger than the following size, and keep a space of 10 cm or more from the distribution line.

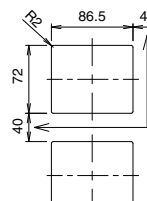
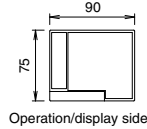
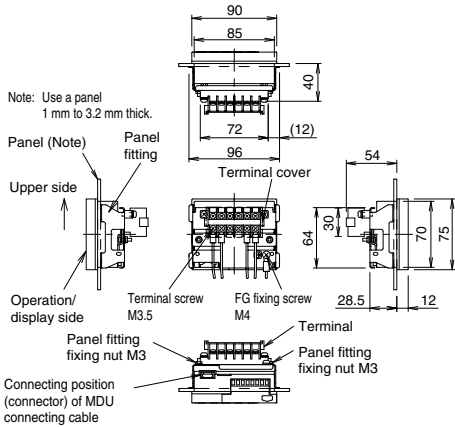

Front-panel cutout

Model	A	B
NF250-SEV with MDU	198	158
NF250-HEV with MDU	208	
NF400-SEV with MDU	244	205
NF400-HEV with MDU	374	
NF800-SEV with MDU(N:630)	253	221
NF800-SEV with MDU	263	
NF800-HEV with MDU	383	

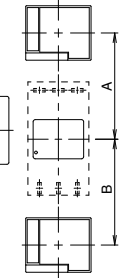

MDU panel mounting position

Note: In the case of front connection, keep a sufficient distance from the connecting wires and insulating barrier.

#### Terminal arrangement

Secure the wires with cable clamps, etc.

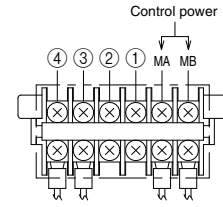

MDU model	Spec.	①	②	③	④
MDU-BN	No transmission	—	—	—	—
MDU-BP	Pulse output	—	—	Cb	Ca

(Tightening torque 1.2±0.3N·m)

### MDU-BC (CC-Link), MDU-BM (MODBUS)

#### Panel mounting

When installing, ensure a distance larger than the following size, and keep a space of 10 cm or more from the distribution line.

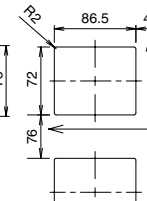
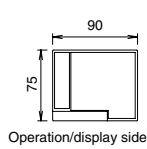
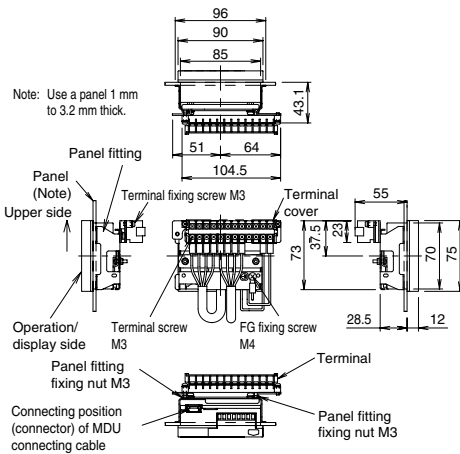

Front-panel cutout

Model	A	B
NF250-SEV with MDU	218	158
NF250-HEV with MDU	228	
NF400-SEV with MDU	263	205
NF400-HEV with MDU	393	
NF800-SEV with MDU(N:630)	272	221
NF800-SEV with MDU	282	
NF800-HEV with MDU	402	

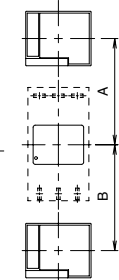

MDU panel mounting position

Note: In the case of front connection, keep a sufficient distance from the connecting wires and insulating barrier.

#### Terminal arrangement

Secure the wires with cable clamps, etc.

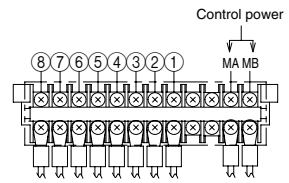

MDU model	Spec.	①	②	③	④	⑤	⑥	⑦	⑧
MDU-BC	CC-Link	SLD	DG	DB	DA	SLD	DG	DB	DA
MDU-BM	MODBUS	SLD	485 <sup>+</sup>	485 <sup>-</sup>	Ter	SLD	485 <sup>+</sup>	485 <sup>-</sup>	Ter

(Tightening torque 0.6±0.1N·m)

#### Breaker mounting

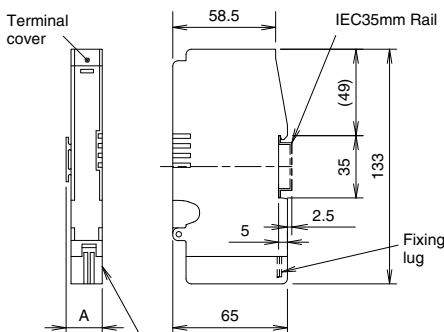

MDU spec.	A
No transmission, Pulse output	21
CC-Link	28

#### Terminal arrangement

Figure is removed the terminal cover.

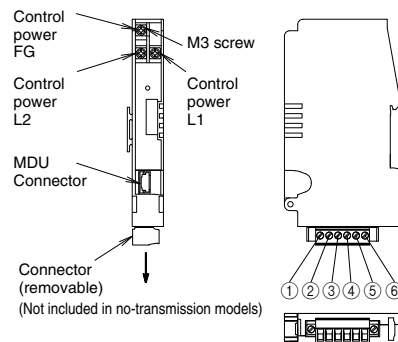

MDU spec.	①	②	③	④	⑤	⑥
No transmission	—	—	—	—	—	—
Pulse output	—	—	—	Cb	Ca	—
CC-Link	—	SLD	—	DG	DB	DA

(Tightening torque Line side 0.6±0.1N·m, Load side 0.55±0.05N·m)

#### MDU terminal arrangement

In the figure below the terminal cover is removed. Secure the wires with cable clamps, etc.

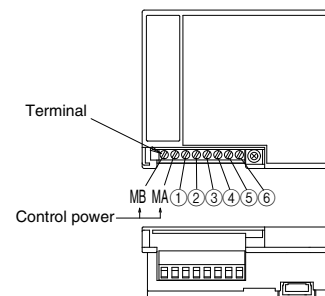

Model	Spec.	①	②	③	④	⑤	⑥
MDU-BN	No transmission	—	FG	—	—	—	—
MDU-BP	Pulse output	—	FG	—	—	Cb	Ca
MDU-BC	CC-Link	—	FG	SLD	DG	DB	DA
MDU-BM	MODBUS	—	FG	SLD	485 <sup>+</sup>	485 <sup>-</sup>	Ter

(Tightening torque 0.55±0.05N·m)



## NF63-HDV



NF63-HDV

Model				NF63-HDV	
Rated current In(A)		15 20 30 40 50		15 20 30 40 50	
Reference ambient temperature 40°C					
Number of poles				2 3	
Rated insulation voltage Ui(V)				600 690	
Rated short-circuit breaking capacity(kA)	IEC 60947-2 (Icu/lcs)	DC	400V	10/5	
			600V	-	
Standard attached parts (front connection)				Terminal screw: M5×14 (2P: 4pcs, 3P: 6pcs) Mounting screw: M4×0.7×55(2P and 3P: 2pcs) Insulation barrier: (2P: 1pcs, 3P: 2pcs)	

### Operating Characteristics

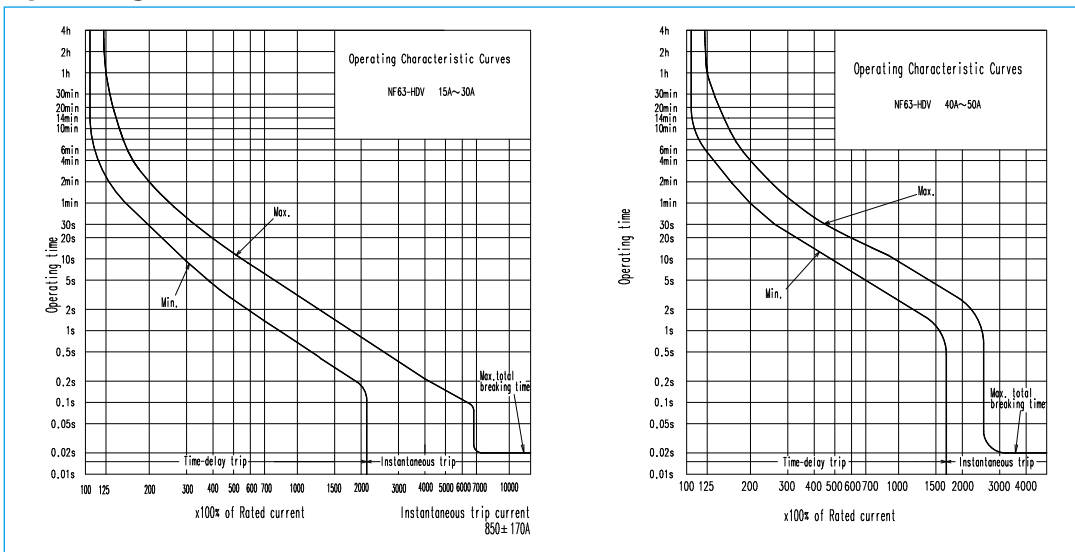

### Temperature Compensation Curve

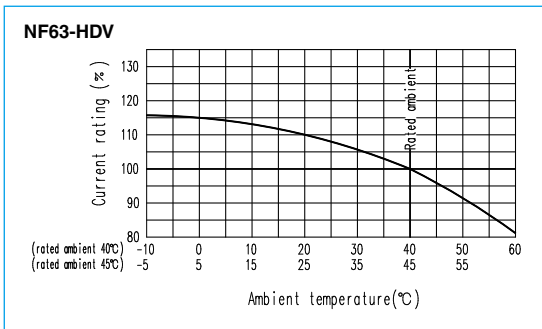

### Internal Accessories

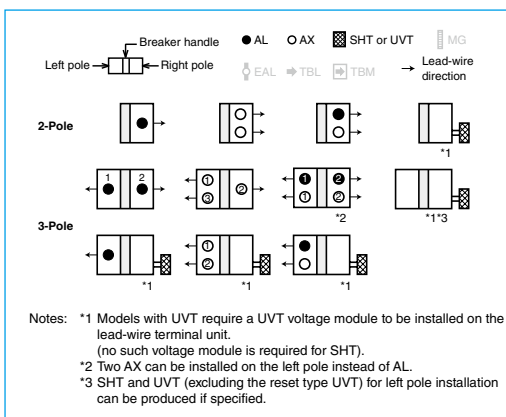

### External Accessories

NF63-HDV								
Accessories		Type name	Reference page	Accessories		Type name	Reference page	
Operating handle	F	2P F-05SV2	123	Terminal cover	Small	2P TCS-05SV2	128	
		3P F-05SV				3P TCS-05SV3		
	V	2P V-05SV2	125		Large	2P TCL-05SV2		
	3P V-05SV	3P TCL-05SV2L						
Lock cover	LC	LC-05SV	135		Rear	BTC		2P BTC-05SV2
Handle lock device	HL(*1)	HLF-05SV	134					3P
		HLN-05SV		3P BTC-05SV3				
		HL-S		3P BTC-2SV3				
Note *1 HLF types are used for OFF lock and HLN types for ON lock.				Plug-in	PTC	2P PTC-05SV2		
				IEC35mm rail mounting adapters		DIN-05SV	143	

Outline Drawing

NF63-HDV 2P

Front connection

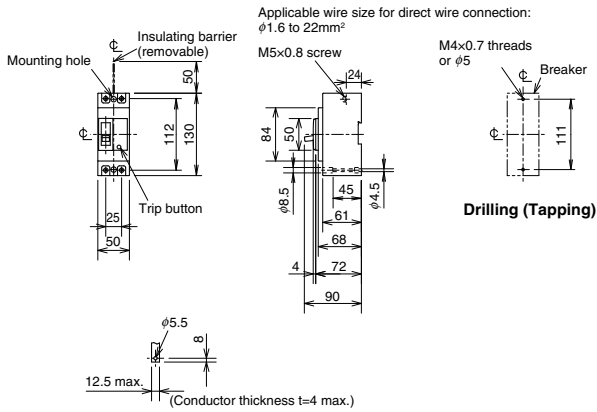

Conductor drilling for direct connection

Rear connection

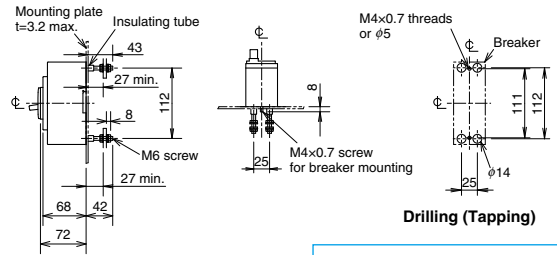

Drilling (Tapping)

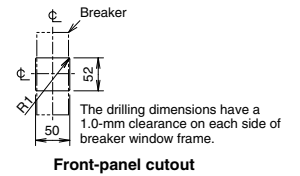

Front-panel cutout

Plug-in

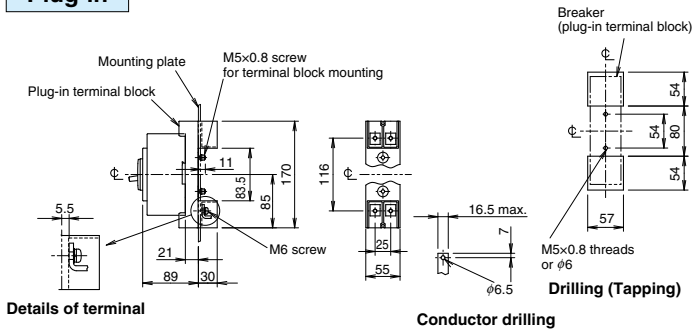

Details of terminal

Conductor drilling

NF63-HDV 3P

Front connection

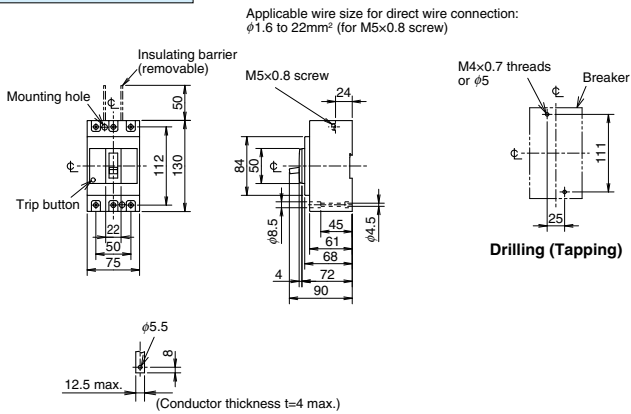

Conductor drilling for direct connection

Rear connection

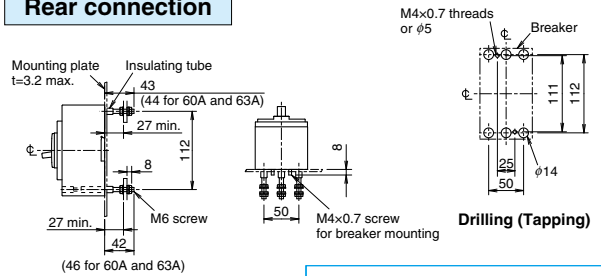

Drilling (Tapping)

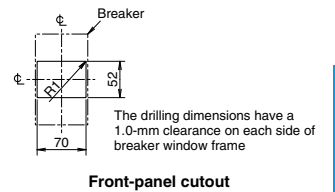

Front-panel cutout

## NF125-HDVA NF250-HDVA



NF250-HDVA

Model				NF125-HDVA	NF250-HDVA	
Rated current In(A) Reference ambient temperature 40°C				125	125 150 175 200 225	250
Number of poles				4		
Rated insulation voltage Ui(V)				1000		
Rated short-circuit breaking capacity(kA)	IEC 60947-2 (Icu/Ics)	DC	1000V	10/5		
Standard attached parts (front connection)				Terminal screw: M8 bolt x16 (4pcs) Mounting screw: M4x0.7x55(4pcs) Insulation barrier: (6pcs)		

### Operating Characteristics

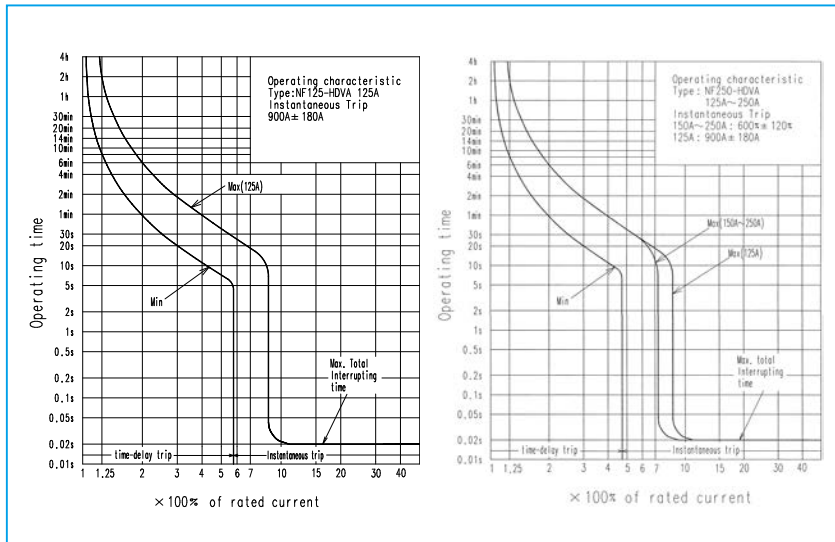

### Temperature Compensation Curve

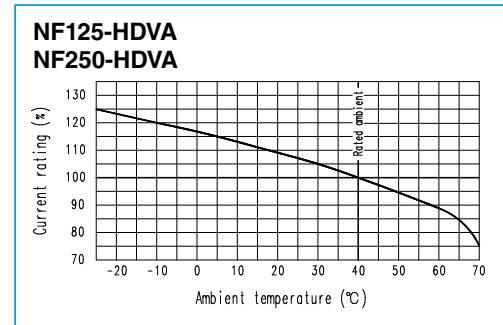

### Internal Accessories

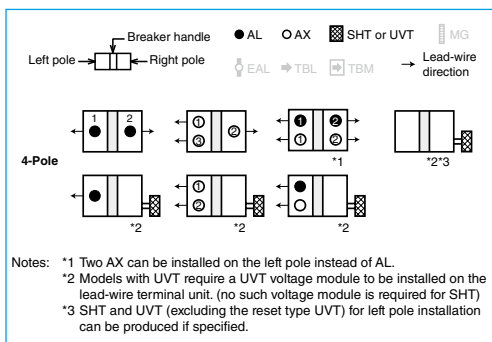

### External Accessories

#### NF125-HDVA/NF250-HDVA

Accessories		Type name	Reference page	Accessories		Type name	Reference page
Operating handle	F	F-2SV	123	Terminal cover	Large	TC-L 4P	TCL-2SV4 128
	V	V-2SV	125		Note *1 HLF types are used for OFF lock and HLN types for ON lock.		
Lock cover	LC	LC-05SV	135				
Handle lock device	HL(*1)	HLF-05SV	134				
		HLN-05SV					
	HL-S	HLS-2SV					

Outline Drawing

NF125-HDVA/NF250-HDVA 4P

Front connection

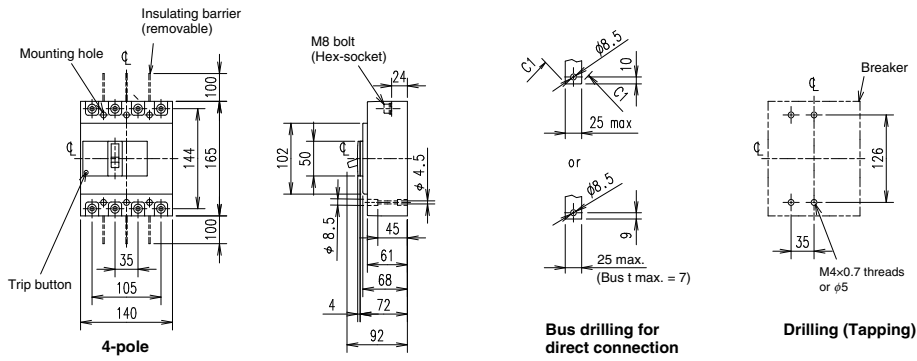

Rear connection

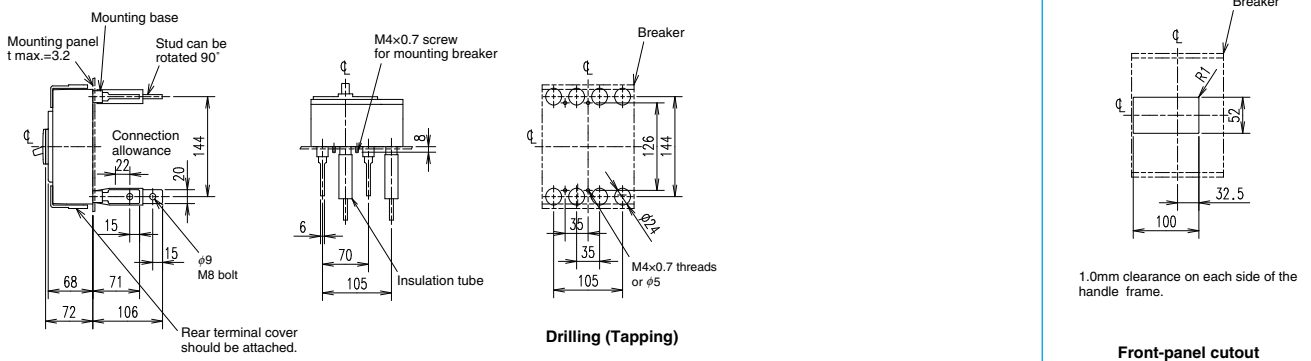

Arc-Space

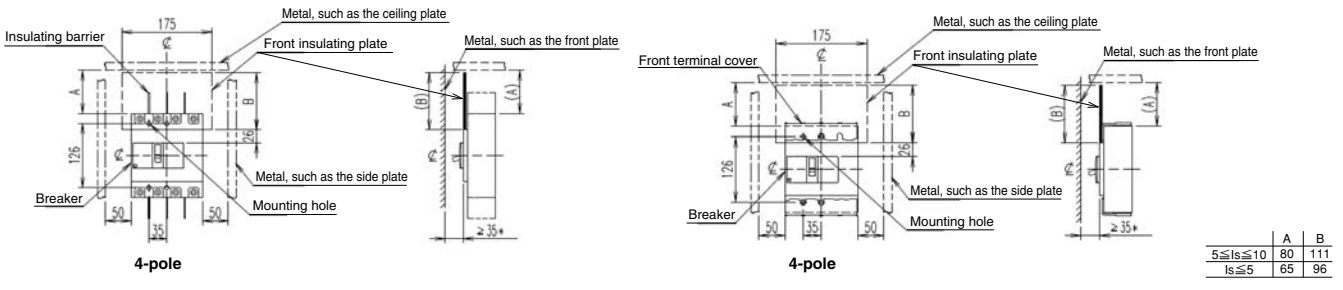

### NF400-HDW NF800-HDW



NF800-HDW

Model		NF400-HDW		NF800-HDW	
Rated current In(A) Reference ambient temperature 40°C		250 300 350 400		500 600 630 700 800	
Number of poles		3		4	
Rated insulation voltage Ui(V)		800		1000	
Rated short-circuit breaking capacity(kA)	IEC 60947-2 (Icu/Ics)	DC	1000V	-	10/5
			750V	10/10	10/10
Standard attached parts		Front connection	Mounting screw: M6×72(4pcs) Insulation barrier: (3P: 4pcs, 4P: 6pcs)		Mounting screw: M6×40(4pcs) Insulation barrier: (3P: 2pcs, 4P: 3pcs)
		Rear connection	Mounting screw: M6×72(4pcs)		Mounting screw: M6×40(4pcs)

Note \*1 An auxiliary handle is included with the 4-pole model of the NF800-HDW.

### Operating Characteristics

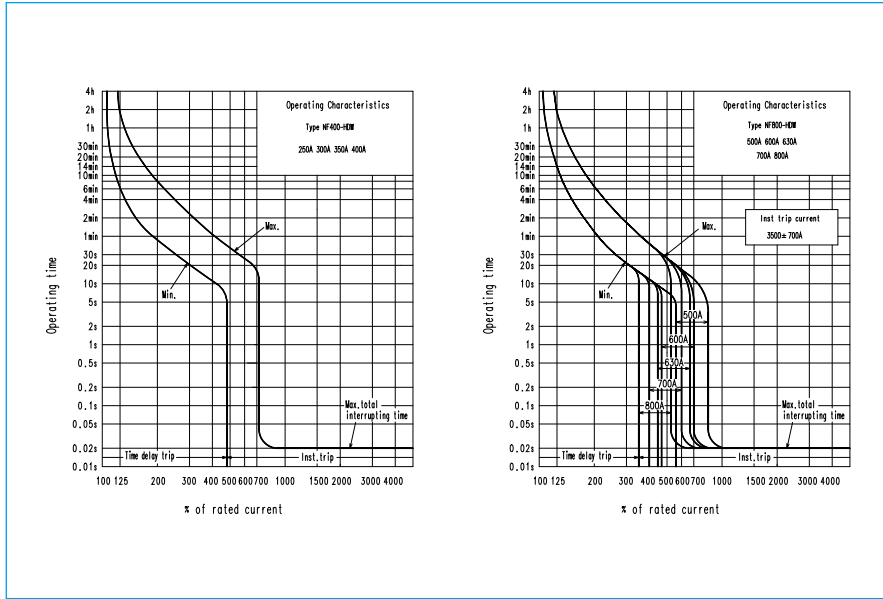

### Temperature Compensation Curve

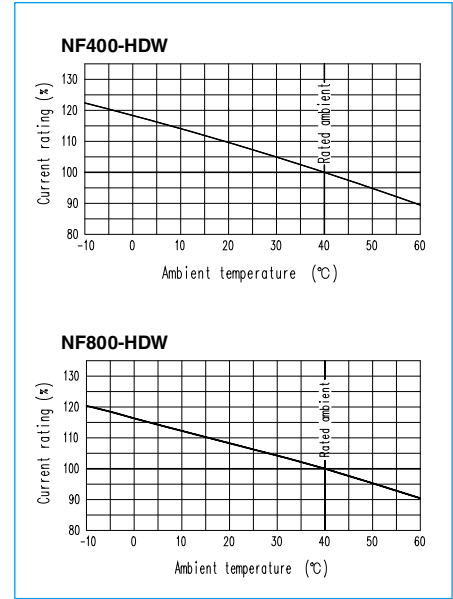

### Internal Accessories

**NF400-HDW**

**NF800-HDW**

Notes

- \*1 When UVT is provided, the UVT voltage module will come in the vertical lead wire terminal block type. (SHT does not have a voltage module.)
- \*2 SHT and UVT are installed on the right pole as standard. Please specify if SHT and UVT are required to be installed on the left pole.
- \*3 In the case where three or more accessories are installed on the left pole side and AL, AX or AL and AX are installed on the pole on which SHT, SHT or UVT is installed, SLT will be manufactured to order.
- \*4 When AL, AX or AL and AX are installed on the pole on which UVT is installed, the UVT voltage module must be installed separately.

Remarks

- The encircled numbers indicate the order of installation.
- AL-AX for minute load are also available.

### External Accessories

#### NF400-HDW

Accessories		Type name	Reference page
Operating handle	F	F-4S	123
	V	V-4S	125
Terminal cover	Large	3P	TCL-4SW3
		4P	TCL-4SW4
	Skeleton	3P	TTC-4SW3
		4P	TTC-4SW4
Rear	3P	BTC-4HDW3	
	4P	BTC-4HDW4	
Handle lock device	HL	HL-4SW	134
Auxiliary handle	HT	HT-4SW	135

#### NF800-HDW

Accessories		Type name	Reference page
Operating handle	F	F-8S	123
	V	V-8S	125
Terminal cover	Large	3P	TCL-8SW3
		4P	TCL-8SW4
	Skeleton	3P	TTC-8SW3
		4P	TTC-8SW4
Rear	3P	BTC-8HDW3	
	4P	BTC-8HDW4	
Handle lock device	HL	HL-4SW	134
Auxiliary handle	HT	HT-4SW	135

Outline Drawing

NF400-HDW, DSN400-HDW

Front connection

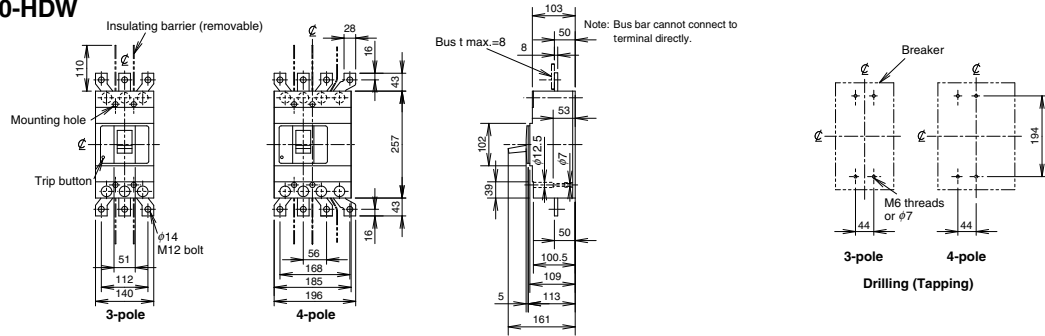

Rear connection

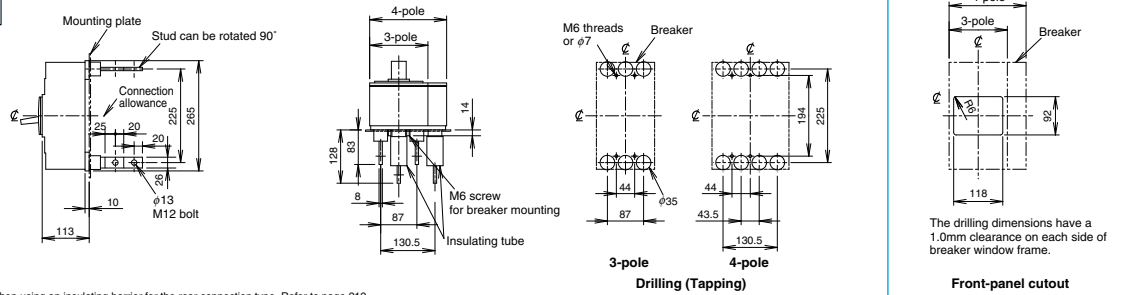

Note. A mounting hole will need to be added when using an insulating barrier for the rear connection type. Refer to page 212.

Arc-Space

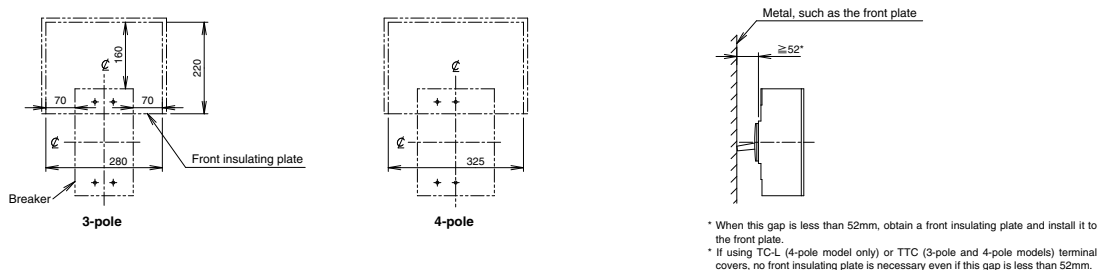

NF800-HDW, DSN800-HDW

Front connection

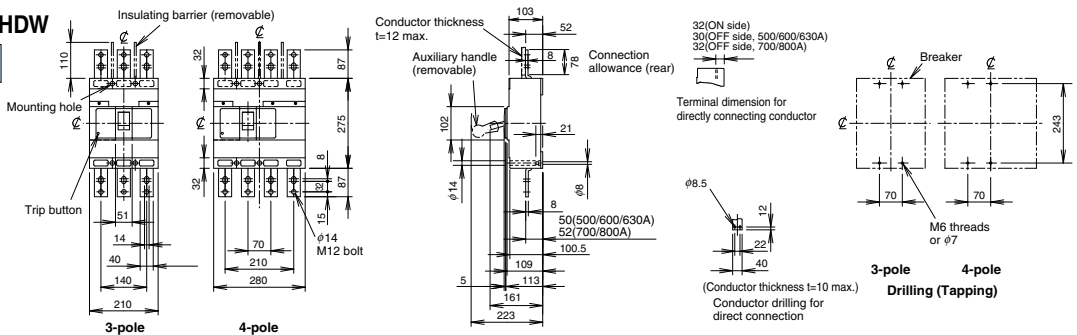

Rear connection

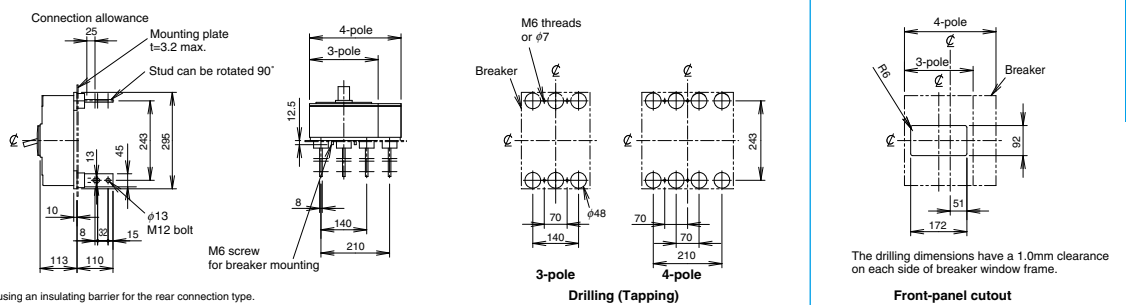

Note. A mounting hole will need to be added when using an insulating barrier for the rear connection type.

Arc-Space

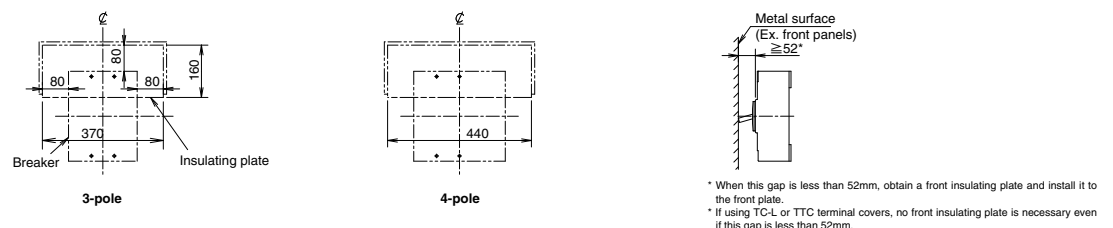

## BH-D6 BH-D10



BH-D6

Model		BH-D6					BH-D10				BH-D10 (For DC)					
Number of poles (P)		1	2	3	4(3+N) <sup>(*)</sup>	2(1+N) <sup>(*)</sup>	1	2	3	4(3+N) <sup>(*)</sup>	1	2				
Instantaneous tripping		Type B, C, D				Type B, C	Type B, C, D				Type B, C					
Rated insulation voltage U <sub>i</sub> (V)		440					440				250					
Rated current I <sub>n</sub> (A) Reference ambient temperature 30°C		0.5	1	1.6	2	3	4	6	10	13	0.5	1	1.6	2	3	4
		16 20 25 32 40 50 63					0.5 1 1.6 2 3 4 6 10 13 16 20 25 32 40				0.5 1 1.6 2 3 4 6 10 13 16 20 25 32 40 50 63					
Rated short-circuit capacity (kA)	IEC 60898-1 EN 60898-1 GB/T 10963.1 (Icn)	AC	230V	6	-			6	10	-			6	-		
			230/400V	6	-			-	10	-			6	-		
			400V	-	6			-	-	10			-	6		
	IEC 60898-2 EN 60898-2 GB/T 10963.2 (Icn)	DC	125V	-					-				10	-		
			250V	-					-				-	10		
		AC	230/400V	-					-				6	-		
	400V	-					-				-	6				

Note \*1 N pole is a switched neutral pole (without overcurrent release device).

## Operating Characteristics

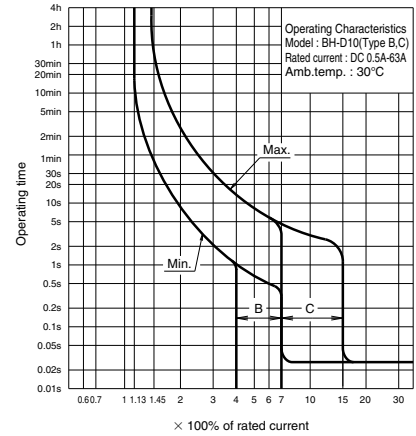
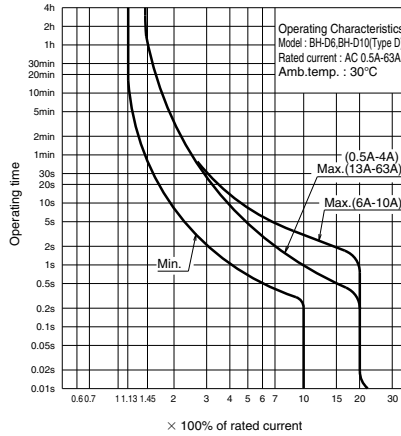
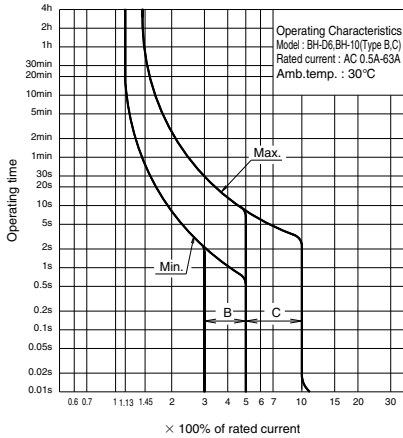

\* When using BH-D10 (for DC) in AC circuit, characteristic curve of BH-D10 (Type B, C) for AC is applied.

## Outline Drawing

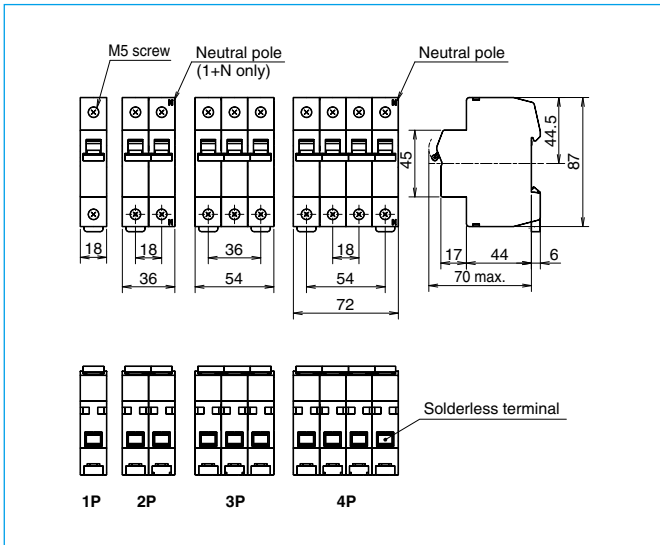

## Temperature Compensation Curve

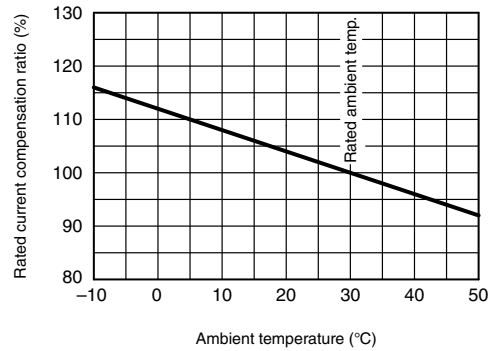

\* In case of installing breakers side by side, reduce the passing current to under 80% of the rated current.

# BH-DN



BH-DN

Model				BH-DN
Number of poles (P)				2 (1+N) (*1)
Instantaneous tripping				Type C
Rated insulation voltage $U_i$ (V)				230
Rated current $I_n$ (A) Reference ambient temperature 30°C				6 10 16 20
Rated short-circuit capacity (kA)	IEC 60898-1 EN 60898-1 GB/T 10963.1 (Icn)	AC	230V	4.5

Note \*1 N pole is a switched neutral pole (without overcurrent release device).

## Operating Characteristics

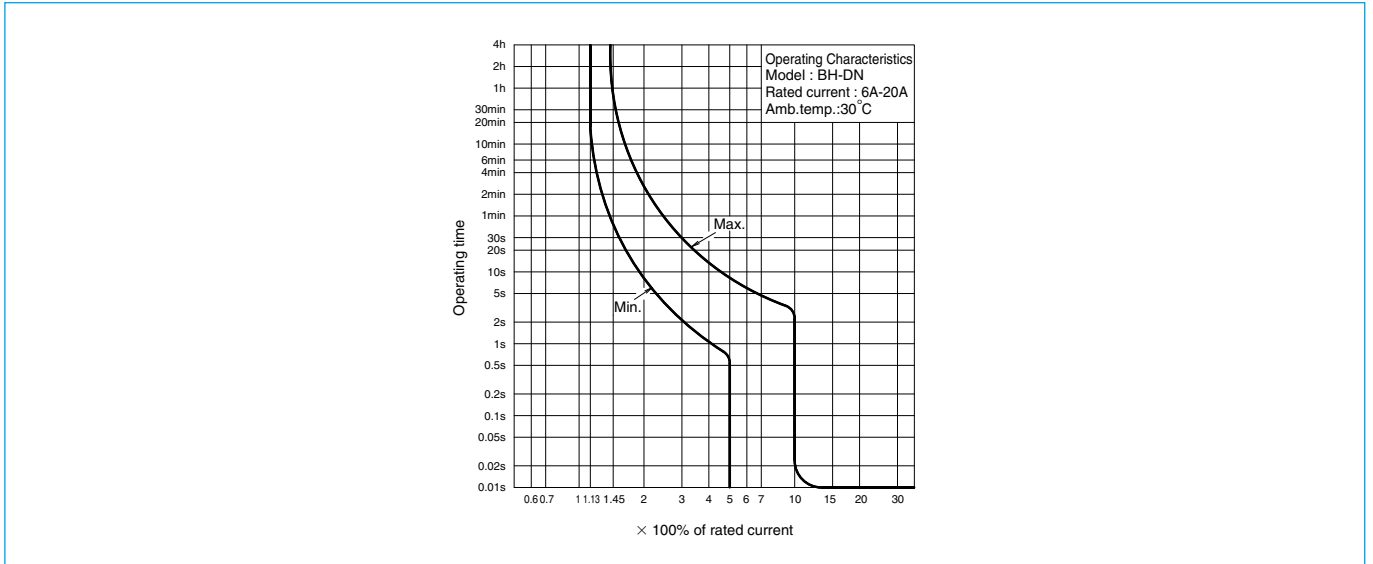

## Outline Drawing

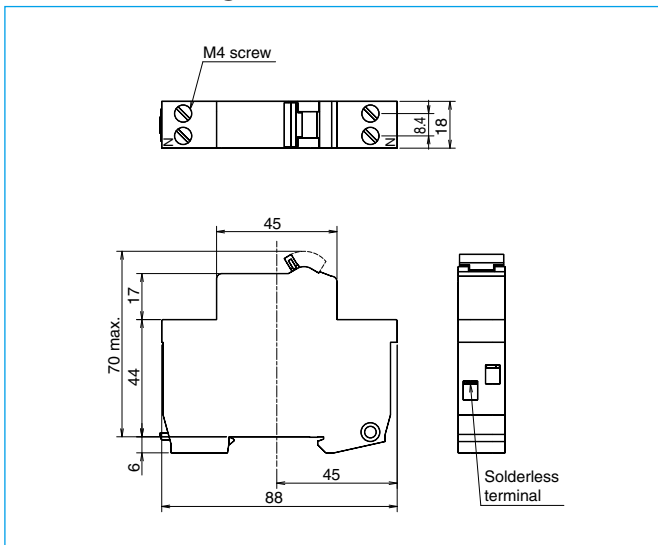

## Temperature Compensation Curve

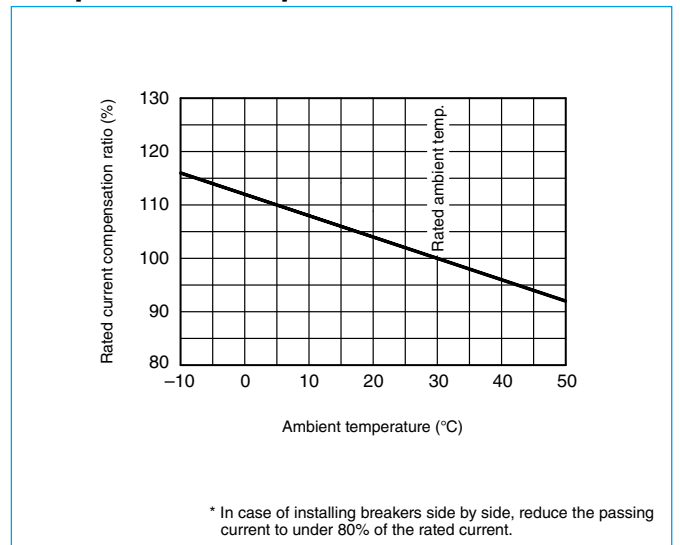

## BV-D



BV-D

Model	BV-D	
Number of poles (P)	2 (1+N) (*1)	4 (3+N) (*1) (*2)
Rated operational voltage U <sub>e</sub> (VAC)	230	230/400
Rated current I <sub>n</sub> (A) Reference ambient temperature 30°C	25	40 63
Rated residual operating current I <sub>Δn</sub> (mA)	30, 300	
Max. operating time at 5I <sub>Δn</sub> (s)	0.04	
Pulsating current sensitivity	Type A	
Residual operation	Dependent on line voltage	
Rated making and breaking capacity I <sub>m</sub> (A)	500 (I <sub>n</sub> 25, 40A) 630 (I <sub>n</sub> 63A)	
Rated conditional short-circuit current I <sub>nc</sub> (kA)	6	
Rated residual making and breaking capacity I <sub>Δm</sub> (A)	500 (I <sub>n</sub> 25, 40A) 630 (I <sub>n</sub> 63A)	
Rated conditional residual short-circuit current I <sub>Δc</sub> (kA)	6	

Notes \*1 N pole is a switched neutral pole (without overcurrent release device).  
\*2 For use to three phase 4-wire type. When wiring to three phase 4-wire, connect the neutral line to the neutral pole. Not available for use to three phase 3-wire type.

## Earth Leakage Tripping Characteristics

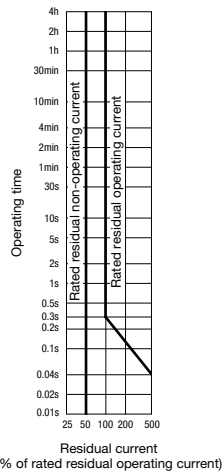

## Outline Drawing

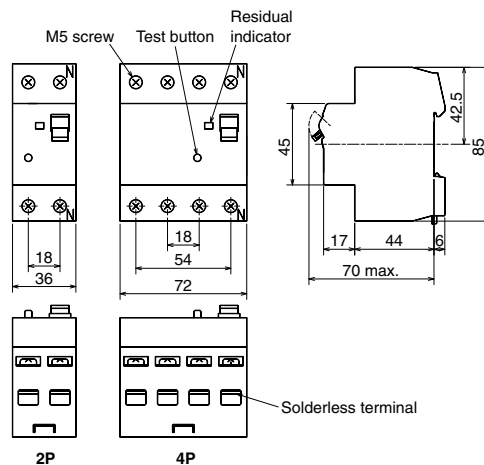

## BV-DN BV-DN6



BV-DN

Model				BV-DN	BV-DN6
Number of poles (P)				2 (1+N) (*1)	
Rated operational voltage U <sub>e</sub> (VAC)				230	
Rated current I <sub>n</sub> (A)				6 10 16 20 25	3 6 10 16 20 25
Reference ambient temperature 30°C				32 40	32 40
Instantaneous tripping				Type C	
Rated current sensitivity ΔI <sub>n</sub> (mA)				30, 100, 300	
Max. operating time at 5IΔ <sub>n</sub> (s)				0.04	
Pulsating current sensitivity				Type A	
Residual operation				Dependent on line voltage	
Rated short-circuit capacity (kA)	IEC 61009-1 EN 61009-1 GB/T 16917.1 (Icn)	AC	230V	4.5	6
Rated residual making and breaking capacity IΔ <sub>m</sub> (A)				500	

Note \*1 N pole is a switched neutral pole (without overcurrent release device).

### Operating Characteristics

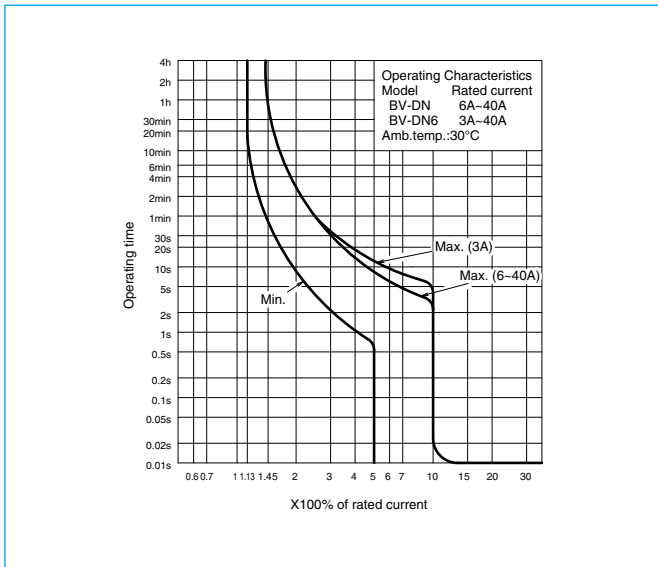

### Earth Leakage Tripping Characteristics

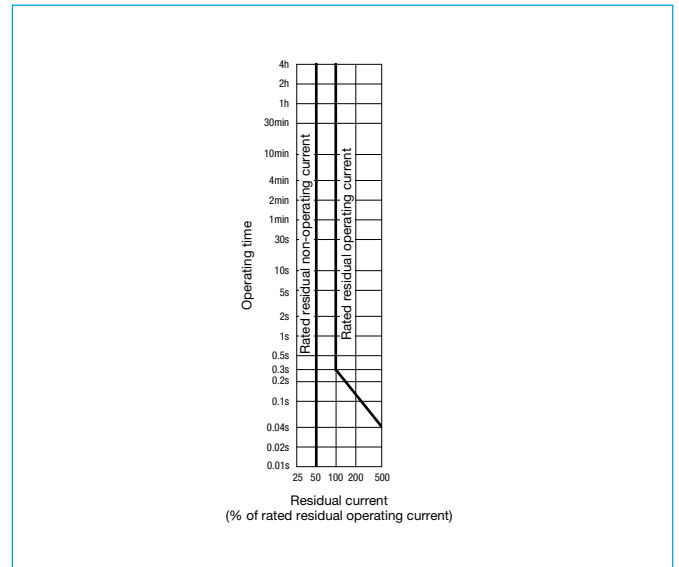

### Outline Drawing

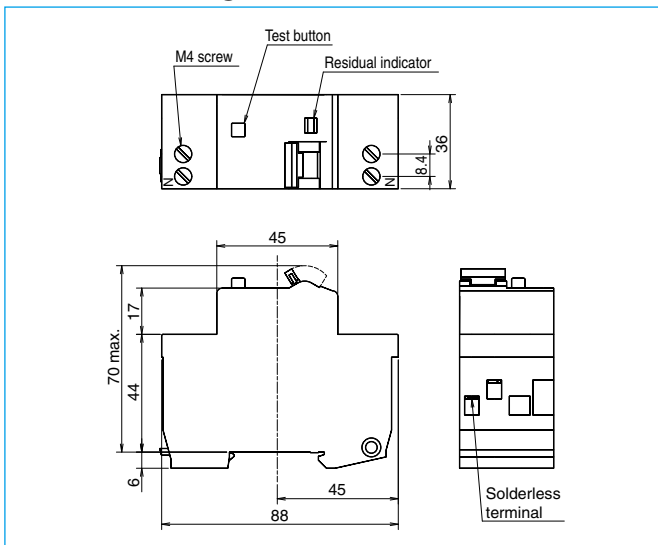

### Temperature Compensation Curve

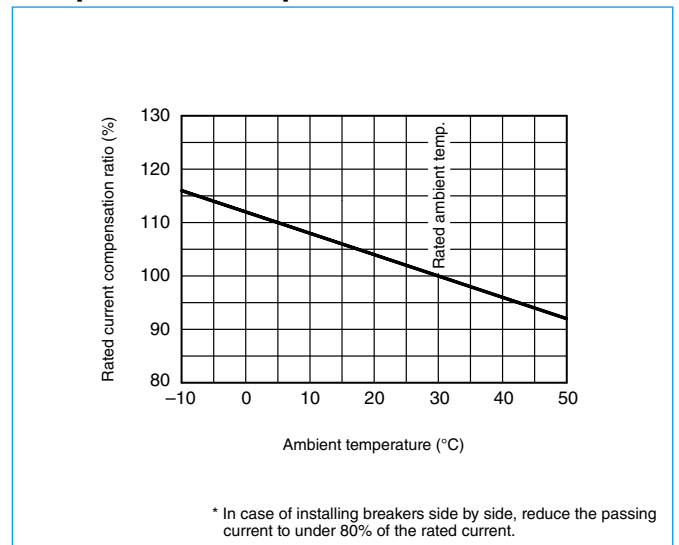

### KB-D



KB-D

Model	KB-D			
Number of poles (P)	1	2	3	4 (3+N) (*1)
Selectivity category	AC-22A class			
Rated insulation voltage $U_i$ (V)	250	440		
Rated voltage $U_e$ (VAC)	230	400		
Rated current $I_n$ (A) Reference ambient temperature 30°C	32 63 80			
Short-time withstand current (A)	20× $I_n$ , 1sec			
Short-time making current (A)	20× $I_n$			

Note \*1 N pole is a switched neutral pole (without overcurrent release device).

### Outline Drawing

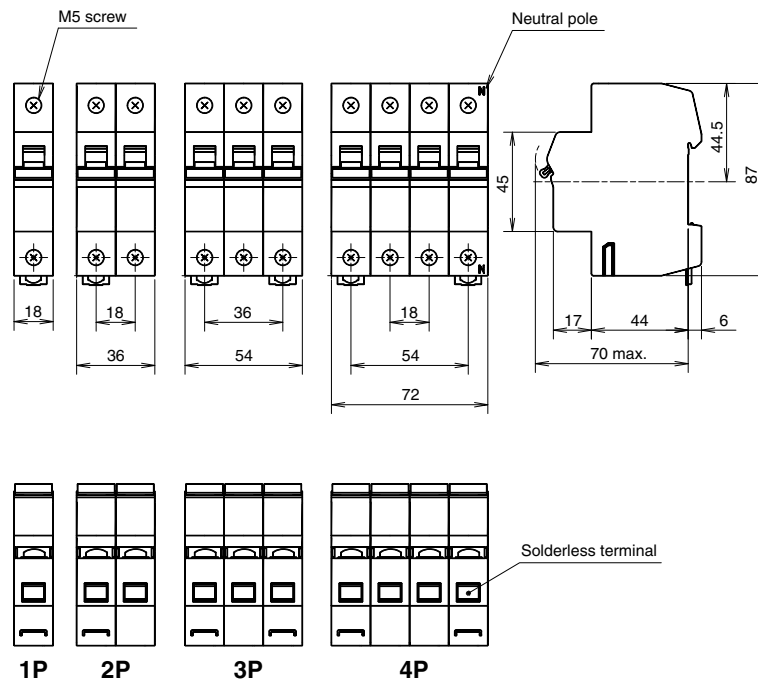

# 7 Characteristics and Dimensions 7 Circuit Protectors

## CP30-BA CP30-HU



CP30-BA



CP30-HU

Frame (A)		30			30				
Model		CP30-BA			CP30-HU				
Number of poles		1	2	3	1	2	3		
Rated impulse withstand voltage $U_{imp}$ (kV)		2.5			2.5				
Rated current (A) Reference ambient temperature 40°C		0.1	0.25	0.3	0.5	1	2	3	5
Rated short-circuit capacity (kA)	UL 1077 CSA C22.2 No.235	Rated voltage (V)	AC (V)	250			250		
			DC (V)	65	125	—	65	125	—
		AC	2.5kA at 250V			2.5kA at 250V 10kA at 125V	10kA at 250V		
	DC	2.5kA at 65V	2.5kA at 125V	—	10kA at 65V	10kA at 125V	—		
	IEC 60934 EN 60934	Rated insulation voltage $U_i$ (V)		250			250		
		AC	2.5kA at 230V			2.5kA at 230V 10kA at 120V	10kA at 230V		
DC		2.5kA at 60V	2.5kA at 120V	—	10kA at 60V	10kA at 120V	—		
EN 60947-2 IEC 60947-2 (lcu/lcs)	Rated insulation voltage $U_i$ (V)		250			250			
	AC	2.5/2.5kA at 230V			2.5/2.5kA at 230V 10/10kA at 120V	10/10kA at 230V			
	DC	2.5/2.5kA at 60V	2.5/2.5kA at 120V	—	10/10kA at 60V	10/10kA at 120V	—		
AC/DC common use		●			— (*1)				
Operating characteristics		Instantaneous type (I) Medium type (M),(MD) Slow type (S),(SD) Fast type (F)			Instantaneous type (I) Medium type (M),(MD) Slow type (S)				
Mode of tripping		Instantaneous type (I): magnetic only [MO] Other type (M, MD, S, SD, F):hydraulic-magnetic [HM]			Instantaneous type (I): magnetic [MO] Other type (M, MD, S):hydraulic-magnetic [HM]				

Note \*1 The 3-pole products are for AC use only.

## Operating Characteristics

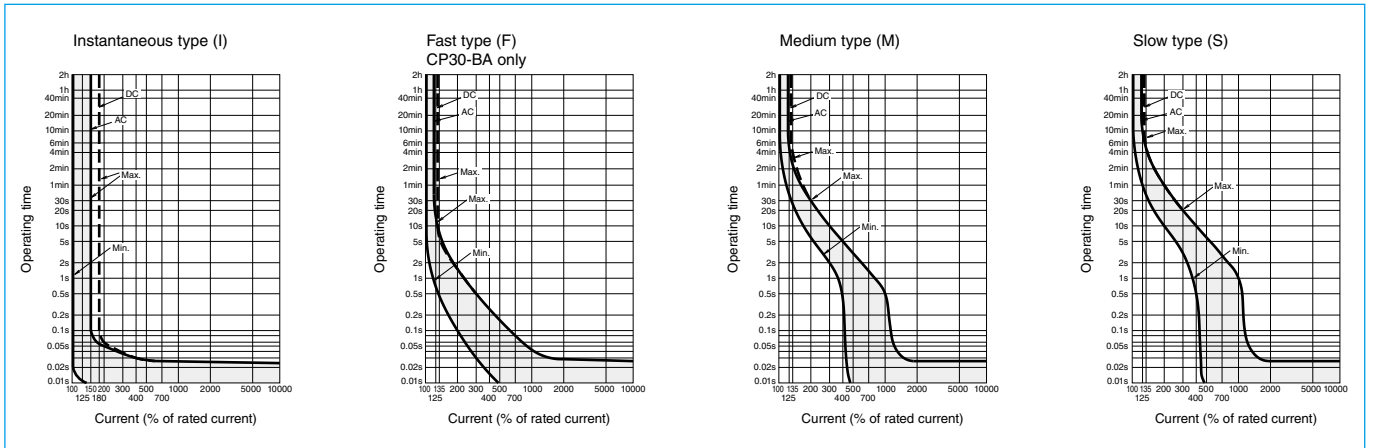

## Outline Drawing

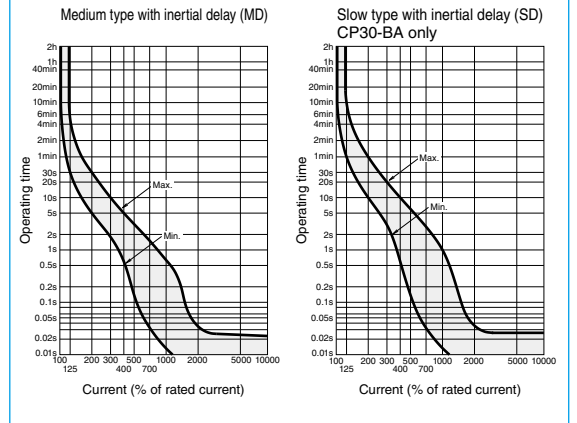
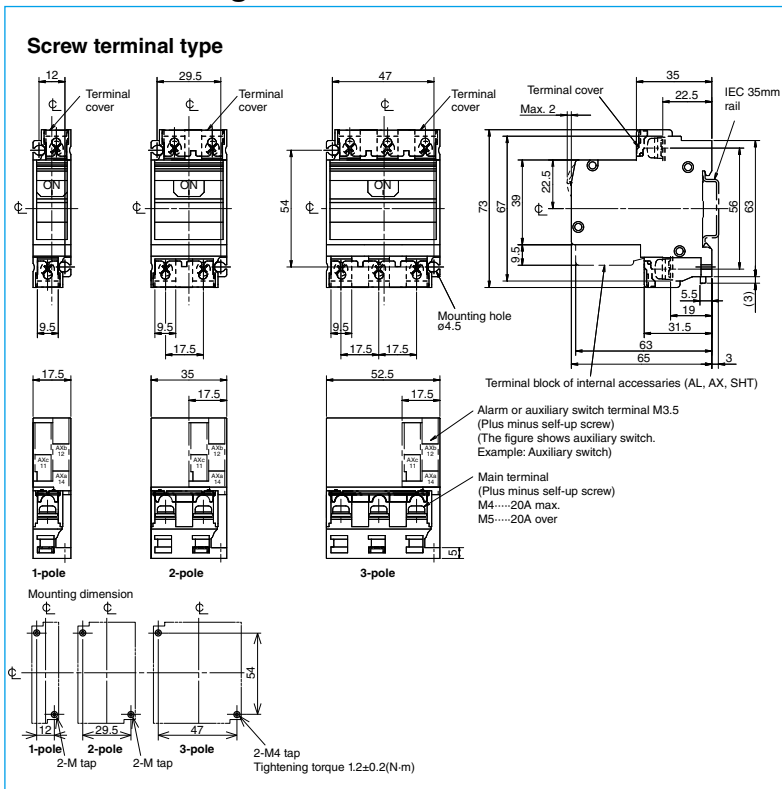

## Temperature Characteristics Curve

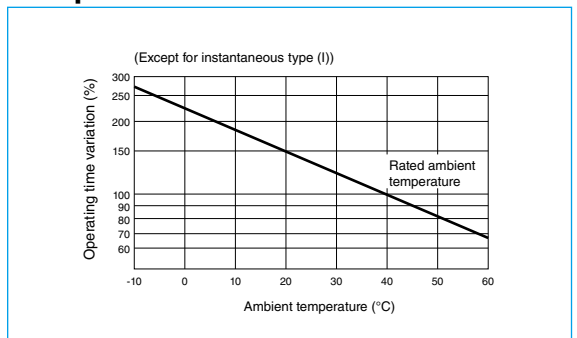

## (1) Dimensions of electrical operated circuit breakers

The following concept is applied for the dimensions of the electrical operated circuit breaker. Please understand this before using this type of breaker.

Connection method	Outline dimensions listing method			
Front connection (Rear connection)	Model	Listed page	Model	Listed page
	NF125-CV/SV/HV NV125-CV/SV/HV NF125-UV	229 (*1)	NF400-CW/SW/SEW/HEW/REW NF630-CW/SW/SEW/HEW/REW NF400-UEW (3P)	230
	NF125-SEV/HEV/RV/ZEV NF250-CV/SV/HV/SEV/HEV NF250-RV NF125-SGV/LGV/HGV/RGV NF160-SGV/LGV/HGV NF250-SGV/LGV/HGV/RGV NV125-SEV/HEV NV250-CV/SV/HV/SEV/HEV NF250-UV	230 (*1)	NV400-CW/SW/SEW/HEW NF400-UEW (4P) NV630-CW/SW/SEW/HEW NF800-CEW/SEW/HEW/REW/SDW NF800-UEW NV800-SEW/HEW NF1000-SEW, NF1250-SEW/SDW NF1600-SEW/SDW	
	Rear connection Plug-in	The drilling dimensions and connection related dimensions are the same as the dimensions for the breaker body. Refer to the dimension drawings of each model. Note that for the rear connection type, four mounting holes are required even for the 2-pole or 3-pole types.		

## (2) Front connection (Rear connection)

NF125-CV, NF125-SV, NF125-HV  
NV125-CV, NV125-SV, NV125-HV

### Front connection

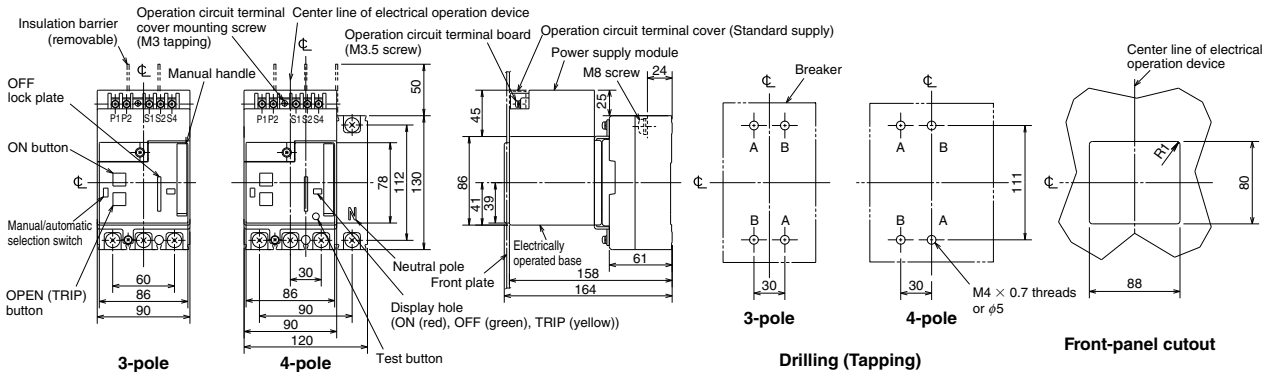

Remarks: 1. This cannot be mounted on the 2-pole breaker.  
2. The test button is equipped only on the earth leakage circuit breaker.

NF125-SEV, NF125-HEV, NF125-RV  
NF250-CV, NF250-SV, NF250-HV, NF250-SEV, NF250-HEV, NF250-RV  
NV125-SEV, NV125-HEV  
NV250-CV, NV250-SV, NV250-HV, NV250-SEV, NV250-HEV  
NF125-SGV/LGV/HGV/RGV  
NF160-SGV/LGV/HGV  
NF250-SGV/LGV/HGV/RGV

### Front connection

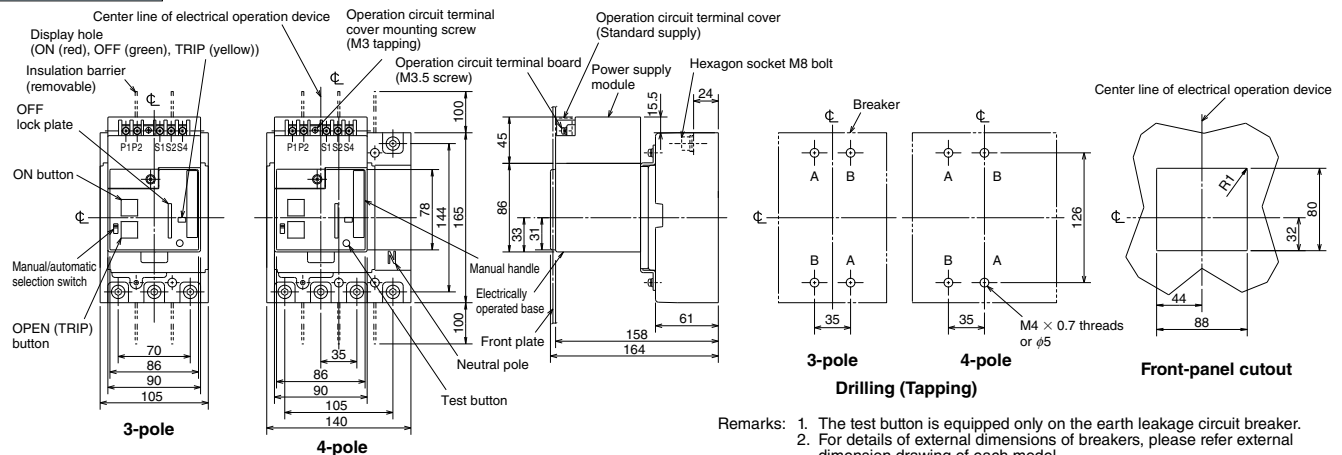

Remarks: 1. The test button is equipped only on the earth leakage circuit breaker.  
2. For details of external dimensions of breakers, please refer external dimension drawing of each model.

Outline Drawing

NF400-CW, NF400-SW, NF400-SEW, NF400-HEW, NF400-REW, NF630-CW, NF630-SW, NF630-SEW, NF630-HEW, NF630-REW Motor drive type

Front connection

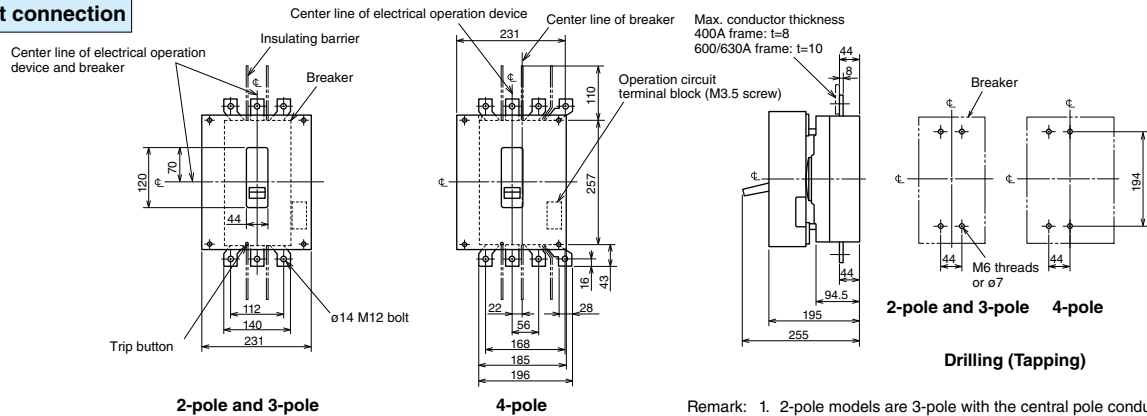

NF400-UEW (3-pole) Motor drive type

Front connection

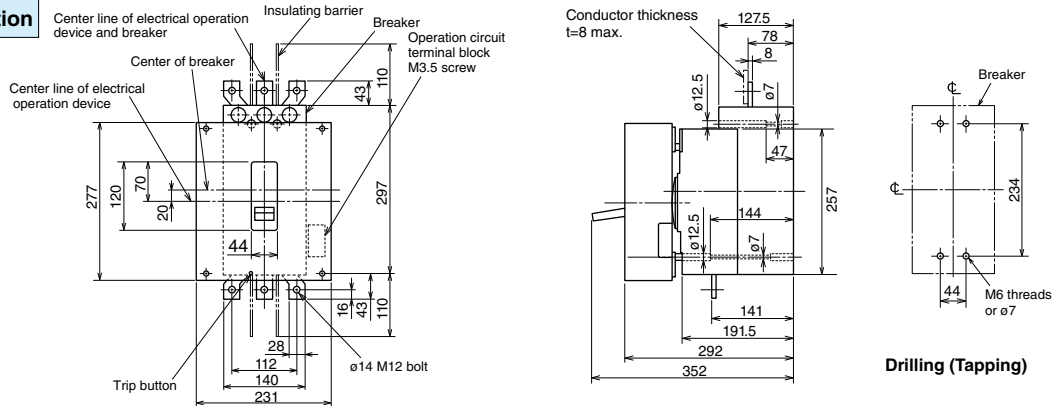

NV400-CW, NV400-SW, NV400-SEW, NV400-HEW, NV630-CW, NV630-SW, NV630-SEW, NV630-HEW  
Motor drive type

Front connection

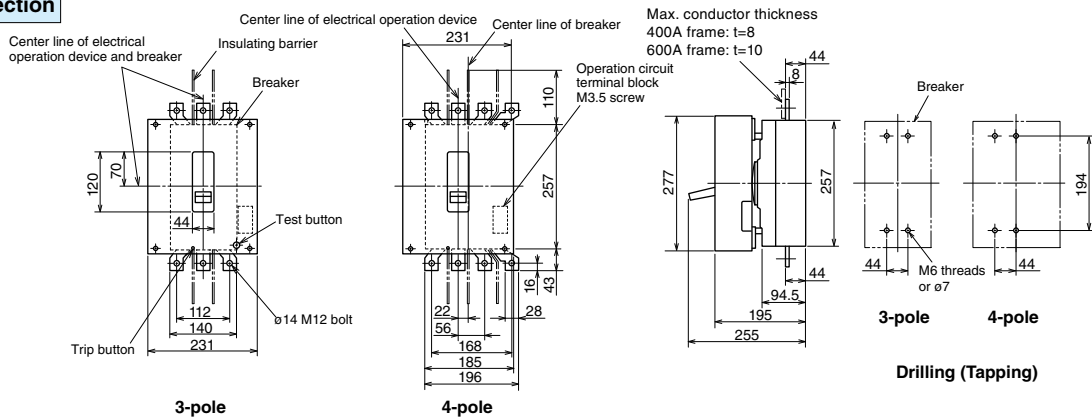

NF400-UEW (4-pole) Motor drive type

Front connection

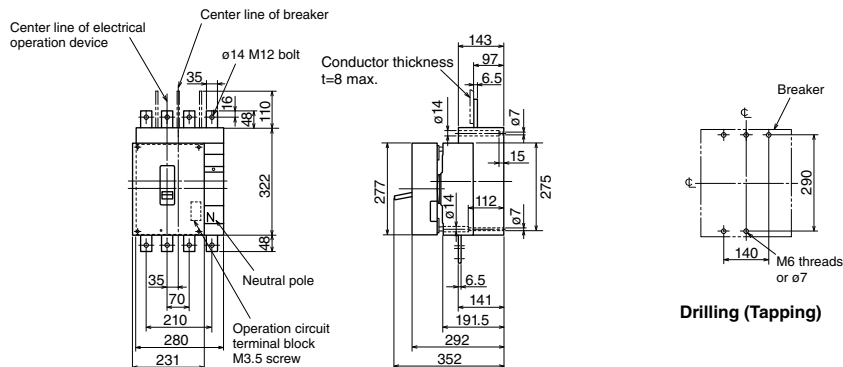

NF800-CEW, NF800-SDW, NF800-SEW, NF800-HEW, NF800-REW Motor drive type

**Front connection**

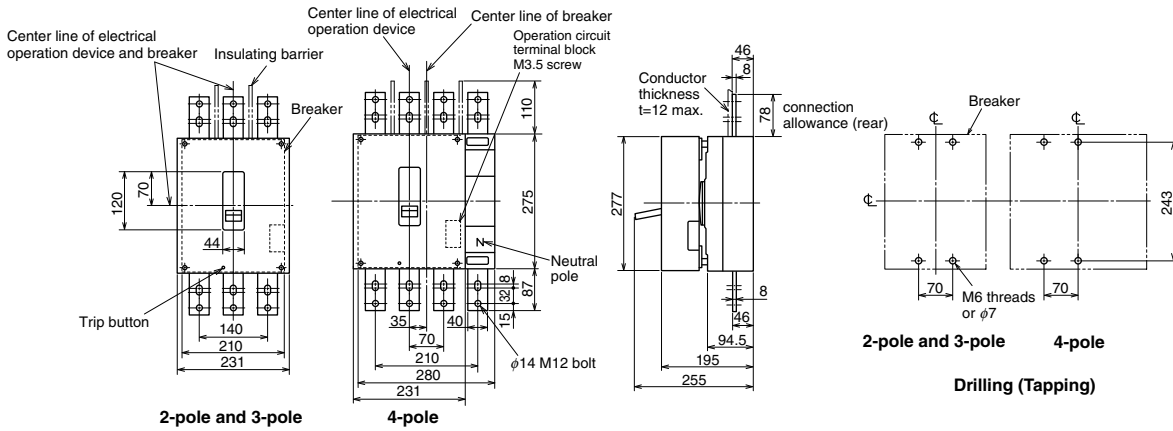

Remark: 1. 2-pole models are 3-pole with the central pole conductor removed.

NF800-U EW Motor drive type

**Front connection**

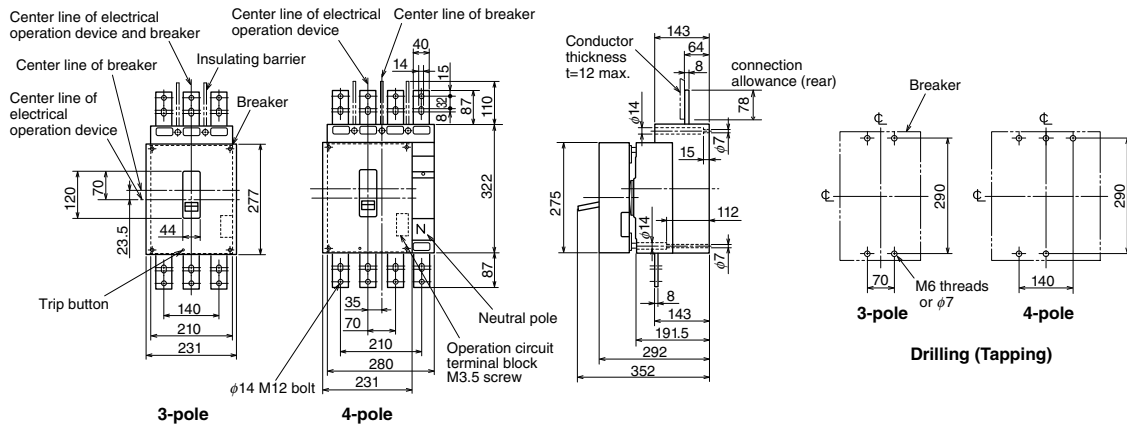

NV800-SEW, NV800-HEW Motor drive type

**Front connection**

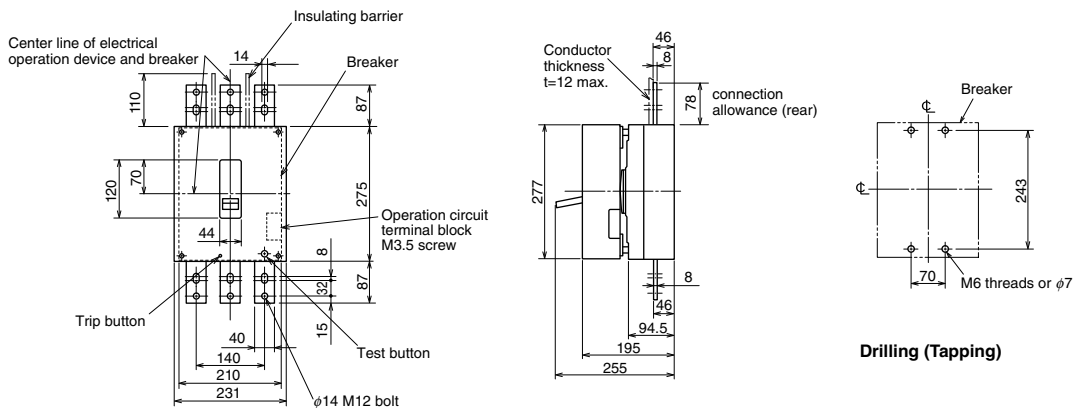



## NF1600-SEW (3-pole) Motor drive type

### Rear connection

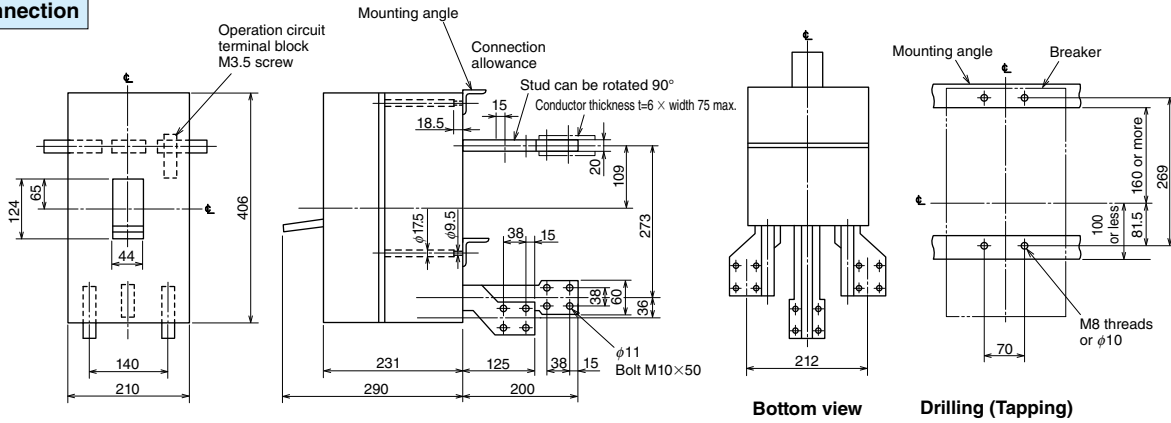

## NF1600-SEW (4-pole) Motor drive type

### Rear connection

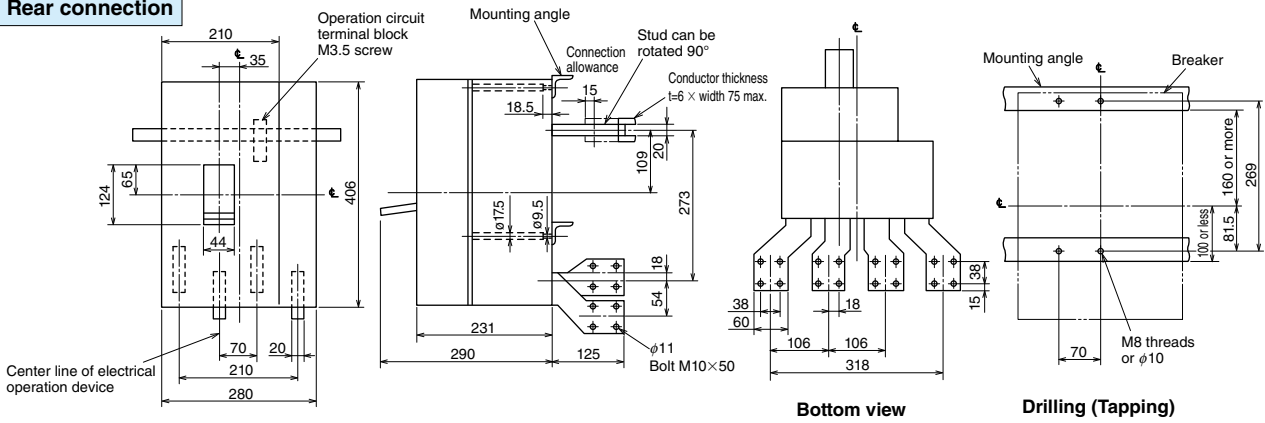

## NF1600-SDW (3-pole) Motor-drive type

### Rear connection

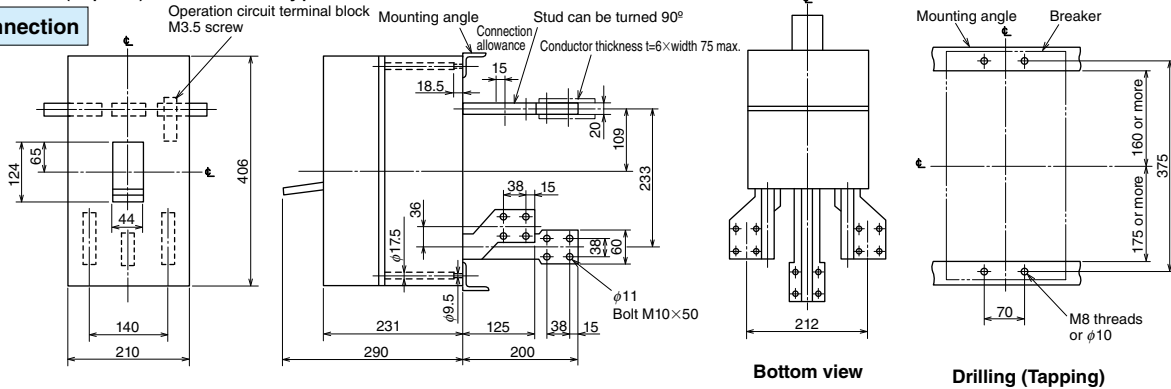

Remark: 2-pole models are 3-pole models with the central pole removed.

## NF1600-SDW (4-pole) Motor-drive type

### Rear connection

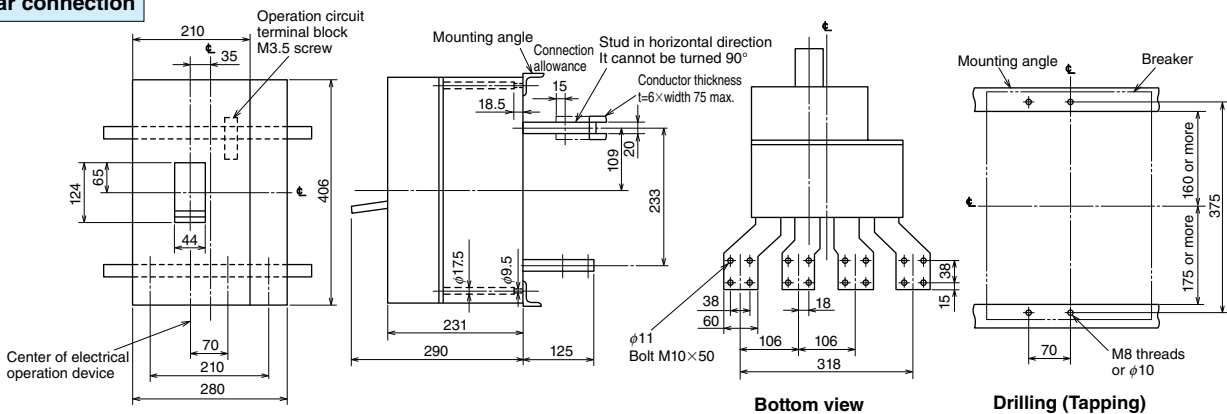

# 8

## Handling and Maintenance

1) Storage and Transportation .....	248
2) Normal Service Conditions .....	248
3) Mounting and Connections .....	249
4) Maintenance and Inspections .....	252
5) Troubleshooting .....	254

# 8 Handling and Maintenance

## 1. Storage and Transportation

### (1) Precautions for storage

**Storage temperature**  
-25°C to +55°C

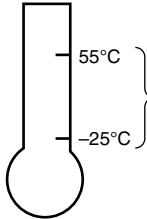

55°C  
-25°C

Store the breaker in this temperature range.

**Avoid moisture**

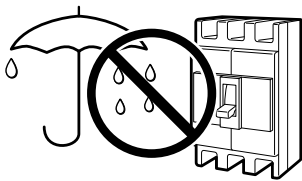

- Do not leave the breaker in a location subject to humidity for long periods of time.
- Store in a location free from condensation.

**Avoid corrosive gases**

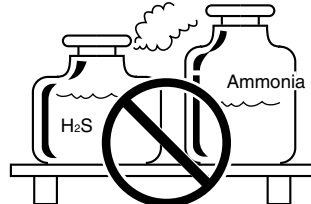

Do not store the product in an atmosphere containing gases such as hydrogen sulfide, sulfur dioxide, or ammonia.  
H<sub>2</sub>S: 0.01ppm or less  
SO<sub>2</sub>: 0.05ppm or less  
NH<sub>3</sub>: 0.25ppm or less

**Keep away from dust**

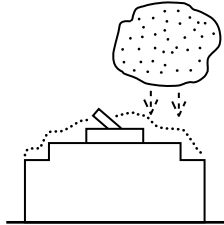

**Place and store in a packing case**

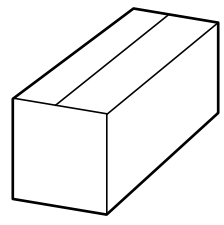

**Avoid direct sunlight**

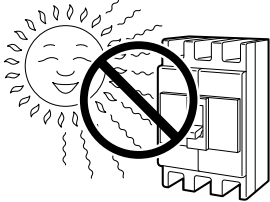

Do not store the breaker in a location where it will be subjected to direct sunlight.

**Store in the OFF or tripped state**

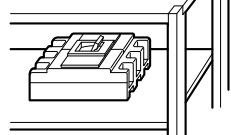

Store the breaker in the OFF state or tripped state.  
However, models that arrive in the ON state can be stored in the ON state.  
When storing for long periods of time, store in the ON state.

### (2) Precautions for transportation

**Carefully pack and transport**



Do not drop the package during transport. When shipping the breaker, make sure to package it carefully.

**Do not carry by holding the front and back of the flush plate**



Do not carry the flush plate type breaker by holding the front and back of the flush plate. The breaker could drop during transport.

**Do not carry by the lead wires**



Do not carry accessories by the lead wires. Excessive force will be applied to the accessories.

**Do not transport upside down (when mounted on IEC 35mm rail)**



Do not transport a panel containing parts mounted on an IEC 35mm rail in an upside down state.

## 2. Normal Service Conditions

- Working ambient temperature ... -10°C to 40°C  
(Note that the 24-hour average value must not exceed 35°C)  
working current reduction rate in ambient temperature exceeding 40°C.  
50°C... 0.9 times  
60°C... 0.7 times
- Relative humidity ... 85% or less with no dew condensation.
- Altitude ... 2000m or less
- Atmosphere ... Free of excessive moisture, oil vapors, smoke, dust, salt, corrosive substances, vibration or impact, etc.

### 3. Mounting and Connections

#### (1) Precautions for mounting

The operating temperature is -10°C to 40°C and the 24-hr average temperature must not exceed 35°C

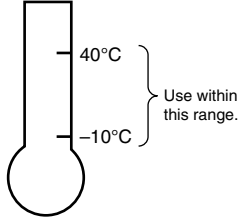

**Avoid moisture**

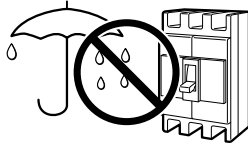

- Do not leave the breaker in humid locations.
- Store in a location free from condensation.

**Avoid corrosive gases**

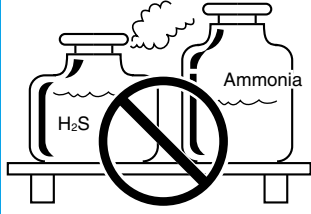

Do not install the product in an atmosphere containing gases such as hydrogen sulfide, sulfur dioxide, or ammonia.

**Avoid vibration and impact**

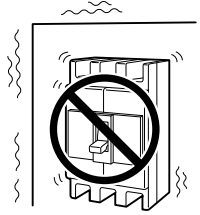

**Keep away from rain, drill shavings, and machining dust**

Failure to do may cause the breaker to malfunction or become inoperable.



Prevent the breaker from direct contact with rainwater, oil, and dust. In particular, take care to prevent contact with conductive materials such as drill shavings from steel plates.

**Prevent the intrusion of foreign matter from the exhaust outlet**

Cover with material such as a sheet when performing work.

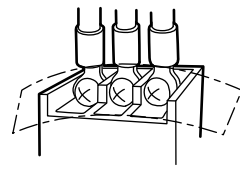

Failure to do so may cause poor contact point conductivity or overheating.

**Do not disassemble**

Doing so may cause the breaker to malfunction or become inoperable.

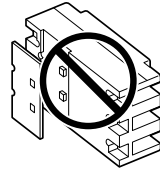

Do not remove the rear cover or the compound applied to screws on the rear surface.

**Use inside of a panel or box**

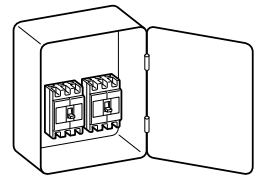

Because the breaker generates an arc, do not leave it exposed, but instead use it inside of a panel or box.

**Avoid direct sunlight**

Failure to do so may cause the breaker to malfunction due to temperature rises.

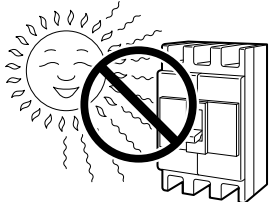

**Use the specified screws**

Use the specified screws (length and quantity) and the specified mounting bracket, and mount them in the correct positions.

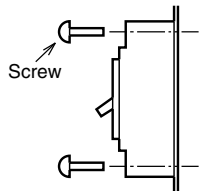

**Do not cover the exhaust outlet**

Doing so may cause breaker performance to drop.



**Prevent liquids such as rainwater from getting inside the panel**

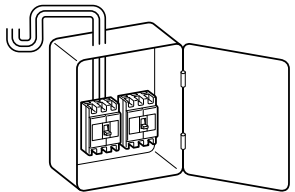

Take measures to prevent conductive liquids such as rainwater from getting inside the panel.

**Do not wipe with thinners, detergents, or chemically treated cloths**

Doing so may cause markings on the identification plate to disappear or may cause insulation performance to drop.

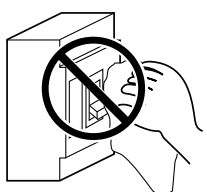

Instead, clean with air or a brush.

**Do not apply tape to the identification plate**

Doing so may cause the identification plate to peel off.

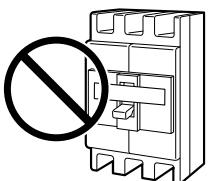

**Keep away from locations subject to strong magnetic fields**

When using a transceiver, use at least 1m away from locations where earth leakage circuit breakers and electronic type breakers are installed.

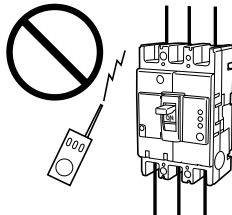

# 8 Handling and Maintenance

## ● Mounting orientation

(1) Because the following models use a completely electromagnetic method of overcurrent tripping, pay attention to the mounting angle as the overcurrent tripping characteristics may vary according to the mounting orientation. Use in a vertical direction is recommended. (The same applies for other model that use a completely electromagnetic method.)

	Model name
Molded case circuit breaker	NF50-FHU, NF100-FHU
Earth leakage circuit breaker	NV50-FHU, NV100-FHU

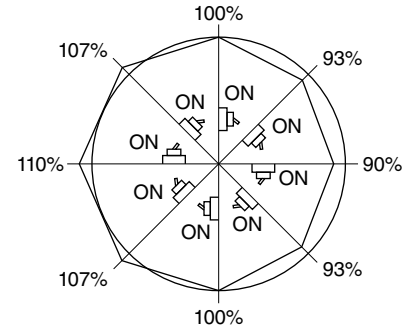

Rate of rated current change due to mounting angle (molded case circuit breakers, earth leakage circuit breakers)

	Model name
Circuit protector	CP30-BA, CP30-HU

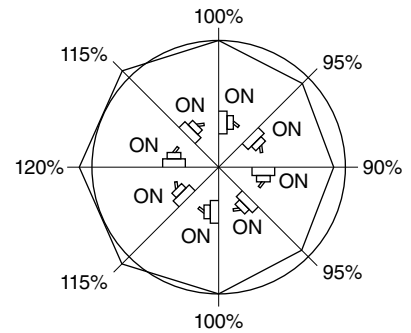

Rate of rated current change due to mounting angle (circuit protectors)

(2) Mounting orientation does not affect thermal-magnetic types, thermal types, or electronic types.

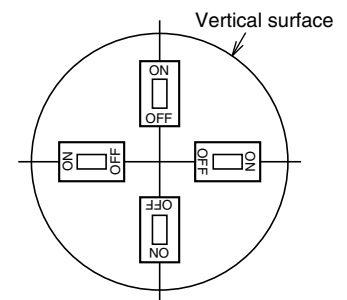

Mounting style that guarantees operating characteristics for complete electromagnetic types

## ● Tightening torque for breaker mounting screws

The case of the breaker is made of plastic. If screws are directly attached to the case of the breaker, install them using the tightening torques shown in the table below and take care to not apply excessive thrust to the breaker.

Tightening torque (N·m)

Models that do not include mounting screws (Note 2)			Models that include mounting screws (Note 1)
Screw material	Steel screws (zinc-plated)	Stainless steel screws	
NF/NV50-SVFU FHU series	M4:1.2±0.2	M4:0.7±0.1	M4: 1.2±0.2 M6: 3.3±0.7 M8: 6±1 M10: 25±5 M12: 45±5 M16: 110±15
FAU series	M4:1.7±0.2 M5:1.7±0.2 (mounted to front plate)	M4:1.1±0.1 M5:1.1±0.1 (mounted to front plate)	

Note 1: If mounting screws are included, use those mounting screws.

Note 2: Combine Phillips pan head screws with a spring washer and plain washer (round type) or use Phillips pan head screws that include a spring washer and plain washer.

Remark: Refer to page 265 for information on whether mounting screws are included.

**(2) Precautions for connections**

**(Secure an insulation distance between phases based on the standard for the panel side.)**

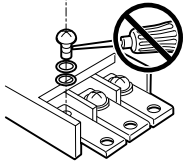
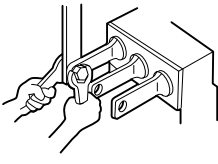
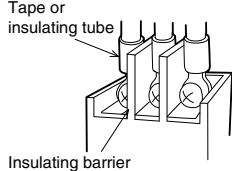
<p><b>Oiling of screws is prohibited</b></p>  <p>Oil will decrease screw friction and cause the screws to loosen. Excessive tightening can cause the screws to break.</p>	<p><b>Do not deform studs</b></p>  <p>When connecting the conductors, perform tightening in a manner that does not deform the studs.</p>	<p><b>Insulate exposed portions of live wires</b></p>  <p>Insulate exposed live terminal wires using means such as tape, an insulating tube, or an insulating barrier if the insulation distance is insufficient, as well as to prevent accidents such as short circuits or earth faults caused by loose metal pieces. Bare live wires are particularly dangerous in the case of 400V or higher! Note: Make sure to mount the insulating barriers in the case of models that come standard with insulating barriers.</p>	<p><b>Use the included terminal screws</b></p> <p>Terminal screws that are too long will cause the insulation distance to be insufficient while terminal screws that are too short will cause tightening force to be insufficient. This could cause overheating to occur. Note: For terminal screw sizes, refer to Table 5-6 on page 102.</p>	<p><b>Use the appropriate crimp terminal</b></p> <p>If connecting a large number of crimp terminals, perform connection by referring to Table 5-6 on page 102. Note: If using crimp terminal connections, refer to Table 5-6 on page 102.</p>
--	---	---	---	---

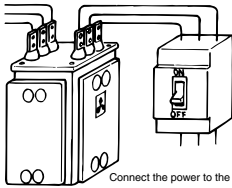
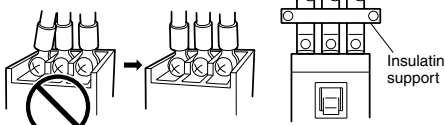
<p><b>Do not connect in reverse</b></p>  <p>Connect the power to the ON side.</p> <ul style="list-style-type: none"> <li>As a rule, do not connect the power load in reverse. If necessary, refer to the specifications and select a model that can be connected in reverse.</li> <li>An insulating barrier should be provided on both the power and load sides of the breakers when using a high voltage circuit where dew condenses easily and the circuit is in reverse connection.</li> </ul>	<p><b>Securely fix conductors to each pole in parallel</b></p>  <p>Mount conductors to each pole in parallel. Because large electromagnetic force is applied to connected conductors according to the accident current, securely fix (tighten) the conductors.</p> <p><b>Electromagnetic force applied per 1m conductor (During 3-phase short-circuit)</b></p> <table border="1"> <thead> <tr> <th rowspan="2">Prospective fault current kA(Pf)</th> <th rowspan="2">Distance between conductors cm</th> <th colspan="2">N/m</th> </tr> <tr> <th>10</th> <th>20</th> </tr> </thead> <tbody> <tr> <td>10 (0.4)</td> <td>10</td> <td>500</td> <td>250</td> </tr> <tr> <td>18 (0.3)</td> <td>10</td> <td>1900</td> <td>950</td> </tr> <tr> <td>25 (0.2)</td> <td>10</td> <td>4500</td> <td>2250</td> </tr> <tr> <td>35 (0.2)</td> <td>10</td> <td>8900</td> <td>4450</td> </tr> <tr> <td>42 (0.2)</td> <td>10</td> <td>12800</td> <td>6400</td> </tr> <tr> <td>50 (0.2)</td> <td>10</td> <td>18200</td> <td>9100</td> </tr> <tr> <td>65 (0.2)</td> <td>10</td> <td>30800</td> <td>15400</td> </tr> <tr> <td>85 (0.2)</td> <td>10</td> <td>52600</td> <td>26300</td> </tr> <tr> <td>100 (0.2)</td> <td>10</td> <td>73000</td> <td>36500</td> </tr> <tr> <td>125 (0.2)</td> <td>10</td> <td>114000</td> <td>57000</td> </tr> </tbody> </table>	Prospective fault current kA(Pf)	Distance between conductors cm	N/m		10	20	10 (0.4)	10	500	250	18 (0.3)	10	1900	950	25 (0.2)	10	4500	2250	35 (0.2)	10	8900	4450	42 (0.2)	10	12800	6400	50 (0.2)	10	18200	9100	65 (0.2)	10	30800	15400	85 (0.2)	10	52600	26300	100 (0.2)	10	73000	36500	125 (0.2)	10	114000	57000
Prospective fault current kA(Pf)	Distance between conductors cm			N/m																																											
		10	20																																												
10 (0.4)	10	500	250																																												
18 (0.3)	10	1900	950																																												
25 (0.2)	10	4500	2250																																												
35 (0.2)	10	8900	4450																																												
42 (0.2)	10	12800	6400																																												
50 (0.2)	10	18200	9100																																												
65 (0.2)	10	30800	15400																																												
85 (0.2)	10	52600	26300																																												
100 (0.2)	10	73000	36500																																												
125 (0.2)	10	114000	57000																																												

**Busbar connection**

- When connecting conductors directly, perform machining by referring to the conductor drilling diagram shown in the outline drawing.
- When connecting conductors to a busbar terminal, pay attention to the insulation distance with the ground. An earth fault prevention barrier is available as an option.

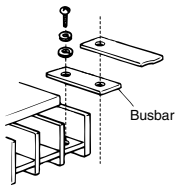

**ELCB connection**

- When using a 3-pole ELCB with single-phase 2-wire models, connect to the left and right poles (poles at both sides) of the ELCB. Do not use the center pole.
- Never connect ELCB units in parallel as it will create a loop circuit, and could burn the magnetic device when the ELCBs operate.
- Never connect the MCCB and ELCB in parallel.

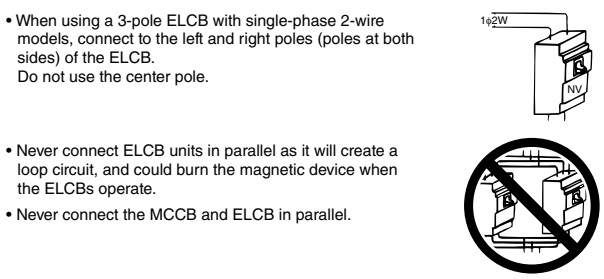

**Clamp connection**

- When directly connecting to the terminal, insert the single strand or stranded wires in straight and then tighten. A commercially-available crimp terminal or busbar can also be connected directly.
- When using stranded wires with a thin core wire, such as appliance wiring material, connect less than 5.5 mm<sup>2</sup> of wire without splitting it. If more than 5.5 mm<sup>2</sup> of wire, connect by splitting it.

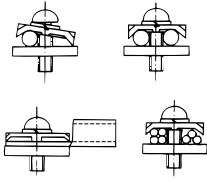

**Solderless terminal connection**

- Untwist the connection wires, align the core wires, and then tighten. The wires will loosen during use, and must be tightened during periodic maintenance.
- Do not solder or bind the ends of the stranded wires.
- Make sure not to catch the insulating sheath of the wire when tightening.

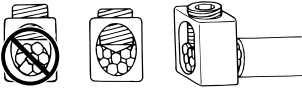

**Connecting spring clamp terminals**

- Do not allow the wire ends to unravel. Unraveled strands may come in contact with each other and cause a phase fault.
- Use the specified wires, ferrules, and crimping tools. Failure to do so will result in connections being inadequate and may cause heat generation or a fire.
- Make sure to strip wires to the appropriate length. Failure to do so will result in poor connections and may cause heat generation or a fire.
- Only copper wires can be used. Using other types of wires may cause heat generation or a fire.
- Do not insert multiple wires into a single wire port. Doing so may damage equipment.
- Wires can be inserted/extracted 50 times.
- Because wires are inserted from the front of the breaker unit, connected wires may interfere with peripheral parts such as panels or external accessories. Observe the allowable bend radius specified by the wire manufacturer and use the appropriate wire to prevent interference with peripheral parts.

**Earth terminals**

- For safety, ground the earth terminals except under certain conditions.

## 4. Maintenance and Inspections

### (1) Initial inspections

After installing the MCCB and ELCB, inspect the following matters before powering the units.

Model	Inspection items	Criterion	Remarks
Common	1. Are there any excessive screws, drilling scraps, wire scraps or any other conductive materials around the terminals?	All conductive material must be removed.	Prevent any foreign conductive matter around the terminals from becoming caught as it may cause an earth fault or short circuit.
	2. Are there any cracks or damage on the cover or base?	No cracks or breaks allowed.	
	3. Is there any dew condensation on the cover, base or terminals?	No dew condensation allowed.	
	4. Measure the insulation resistance with a 500V insulation resistance tester.	5MΩ or more	Refer to Precautions ② for the ELCB.
	5. Are the connector connections tightened securely?	Must be specified tightening torque.	
ELCB	6. Are the ELCB rated voltage and circuit voltage the same?	Voltages must be the same.	
	7. Apply voltage, press the test button and check the operation.	Must trip with an earth leak.	

Earth leakage tripping must occur and it must close again.

#### Precautions

#### ① Withstand voltage test

A guide for the test is given on the following. Do not perform a withstand voltage test exceeding these levels. (Note) Test the operating circuit between the live section and ground.

(Application time: one minute)

(Unit: V)

Main circuit		Auxiliary circuit or control circuit	
Rated insulation voltage	Test voltage (effective value for alternating current)	Rated insulation voltage of operating circuit	Test voltage (effective value for alternating current)
$U_i \leq 300$	2000	$U_{is} \leq 60$	1000
$300 < U_i \leq 690$	2500	$60 < U_{is} \leq 690$	$2U_{is} + 1000$ (min. 1500)

**CAUTION** Applying voltage to the incorrect location or applying a voltage that exceeds standards may cause the product to malfunction.

#### ② Insulation resistance measurement and withstand voltage test

The restrictions a and b apply to the following models.

Applicable models: Earth leakage circuit breaker, Measuring display unit breaker.

Measurement position	Test	Insulation resistance measurement		Withstand voltage test			
		ON	OFF	ON	OFF		
State of handle							
Between live section of main circuit and ground		○	○	○	○		
Between different poles	Line side	Between left - middle, middle - right, left - right poles		△	○	×	○
		Between left - neutral pole, middle - neutral poles, right - neutral poles		○ (*1) (△)	○	○ (*1) (x)	○
	Load side	Between left - middle, middle - right, left - right poles		△	△	×	×
		Between left - neutral poles, middle - neutral poles, right - neutral poles		○ (*1) (△)	○ (*1) (△)	○ (*1) (x)	○ (*1) (x)
Between power - load side terminals		-	○	-	○		
Between main circuit live sections - operating circuit live sections		○	○	○	○		
Between operating circuit live section - ground		○	○	○	○		

Note \*1 Values in parentheses apply for measuring display unit breaker.

### (2) Periodic inspections

To prevent trouble and ensure the breaker operates safely for a long time, inspect the breaker one month after starting use and periodically thereafter according to the environmental conditions.

#### Inspection Interval Guide

1	Clean and dry environment	Once every 2 to 3 years
2	Environment with low levels of dust, corrosive gas, vapors, salt, etc.	Once a year
3	Places other than 1 or 2	Once every six months

Model	Inspection items	Criterion	Remarks
Common (*2)	1. Are any of the conductors loose?	No conductor must be loose.	If any conductor is loose, tighten again with the appropriate torque given in Tables 5-5 and 5-6 on pages 101 to 103.
	2. Is any cover or base cracked? Is any handle damaged?	There must be no cracks, damage or breaks.	
	3. Has the breaker been submerged and infiltrated with water? Is the breaker heavily dirtied by mud or dust?	There must be no infiltration of water, heavy mud or dust.	If water has infiltrated the breaker, it must be replaced with a new product or overhauled by the Mitsubishi Service Center.
	4. Has the temperature risen abnormally?	(1) Visually inspect that none of the studs on the backs of the terminals, or the breaker's tightened or molded sections are discolored from burning. (2) There must be no especially high temperature rise when the current at each phase is balanced. (Tolerable maximum value for terminal temperature rise: 60K) (3) There should be no difference on the left and right side of the base sides if the load current is balanced.	There may be a light temperature difference between the following terminals. ● Between the power side terminal and load side terminal ● Between the center pole terminal and left and right pole terminals.
	5. Can the handle be turned ON and OFF smoothly?	Should operate smoothly.	Open and close a normally closed breaker periodically.
	6. Does pressing the TRIP button result in a trip?	Must be resettable after tripping.	This will clean the contact and prevent abnormal heating. (*1)
NV	7. Test by pressing the TEST button.	Must operate properly and close again.	Test the operation once a month.

Notes : 1. Depending on the usage environment, any lubricants (grease) applied inside the breaker may seep out and become adhered to the outside of the breaker or cause it to become discolored. However, this will not affect the functionality or performance of the breaker and it can continue to be used as is. Any lubricants (grease) that have become adhered can be partially removed using ethanol.

2. Because a silver alloy is used for the contacts (contactors), an oxide film will form on the surface of the contacts when they are in contact with oxygen for a long time. If the resistance value between terminals is particularly high, try cleaning the contact surface by opening and closing the circuit breaker (while energized is recommended) or by operating the trip button.

### (3) Inspection after Tripping

Whether the circuit breaker can be reused or must be replaced after switching off a fault current depends on the intensity of the current which was switched off.

Intensity of trip current, degree of MCCB and ELCB damage, and countermeasures

Intensity of trip current	Degree of MCCB and ELCB damage	Countermeasures
When it is clear that the circuit breaker operated within the time-delay trip range (Overcurrent up to 10 times of rated current)	No abnormality such as contamination around vent observed	Reusable [(The circuit breaker can function 12 times at overload current which is 6 times higher than rated current)]
Relatively low short-circuit current which causes instantaneous tripping ↕ Large short-circuit current close to rated breaking capacity	Soot and dust found near vent ↕ Soot and dust found near handle, remarkable contamination found near vent Molten metal found in circuit breaker Box of box type circuit breaker is severely deformed	Reusable ↕ Replace with a new product

If the intensity of the fault current cannot be estimated, remove the MCCB and ELCB, and measure the insulation resistance. If the specified value (5MΩ) has not been reached, perform a withstand voltage test. If the withstand voltage is within the specified value, the circuit breaker can be used temporarily but it should be replaced with a new part as soon as possible. If both the insulation resistance and withstand voltage are sufficient, the circuit breaker may be judged as reusable. However, it should be checked for abnormalities, such as an abnormal rise in temperature for a set period.

- Measure the insulation resistance and perform the withstand voltage test with the procedures given in section 1 and 2 on page 252.
- Check that the ELCB operates when the test button is pressed.

### (4) Guide to service life

Maintenance and inspection must be conducted according to the environment in which the circuit breaker is installed.

The service life of the circuit breaker cannot be determined just by the number of service years.

A reference to the service life is given below, but the circuit breaker must be diagnosed by a specialist for an accurate reading.

Guide to service life

Degree	Environment	Example	Guide for replacement (years)
Standard usage state	1 Place where air is always clean and dry	Dust-proof and air-conditioned electrical room	Approx. 10 to 20
	2 Indoors, where there is little dust and no corrosive gas	Circuit-breakers housed in distribution panels or boxes within an individual electric room having no dust-proofing or air-conditioning	Approx. 7 to 15
Poor environment	1 Place with gases such as sulfuric acid, hydrogen sulfide, salt and high levels of moisture, but low levels of dust	Geothermal power house, sewage treatment plants, iron and steel works, paper and pulp plants, etc.	Approx. 3 to 7
	2 Place with high levels of gas and dust which humans cannot endure for long periods of time	Chemical plants, quarries, mines, etc.	Approx. 1 to 3

Standard	Size of circuit breaker frame (A)	Number of operating cycles (times)			Number of tripping times by shunt tripping device or undervoltage tripping device, or by trip button
		Energization	No energization	Total	
JIS C 8201-2-1 Ann.2	100 or less	1500	8500	10000	10% of total operating cycles
JIS C 8201-2-2 Ann.2	More than 100, 315 or less	1000	7000	8000	
JIS C 8201-2-1 Ann.2	More than 315, 630 or less	1000	4000	5000	
JIS C 8201-2-2 Ann.1	More than 630, 2500 or less	500	2500	3000	
IEC 60947-2 (*1)	More than 2500	500	1500	2000	

Note \*1 The number of trips by the ELCB test button is one-third the number of energizations.

The operating life shortens as the circuit breaker frame size increases. (Refer to above tables.)

These values may seem low, but since this circuit breaker is a protective device, it basically differs from a switch intended for frequent opening and closing.

For tripping by a shunt tripping device, the life is especially short and special consideration should be taken.

**⚠ WARNING** Continuing user of a circuit breaker which has reached its service life can result in the following problems. Always update the circuit breakers accordingly.

- ① Insulation fault: Risk of burning, internal short-circuit, and electric shock.
- ② Energizing fault: Burning or unnecessary operations caused by overheating of the internal parts, etc.
- ③ Operation fault: ON and OFF operation of the circuit may be disabled.
- ④ Tripping fault: Protection of the load device or wiring, etc., may be disabled.

**⚠ CAUTION** When the operating endurance exceeds the specified value, the above faults could occur or the internal conductor could break, overheat or burn.

# 8 Handling and Maintenance

## 5. Troubleshooting

### (1) Troubleshooting for breaker unit (MCCB, ELCB)

Fault state		Cause		Countermeasures and Actions		
Operation errors	Can't close	Foreign matter in switching mechanism		Replace with a new part		
		Breaker hasn't been reset		Reset again		
		Breaker can't be reset		See below (*)		
	(*) Can't be reset Can't trip Can't turn OFF	Wear due to tripping endurance	Excessive use of shunt trip operation	End of service life	Replace with a new part	
			Reset mechanism is faulty		Replace with a new part	
		Undervoltage trip coil is not excited	Wiring error	Excite by applying rated voltage		
		Resetting time has not elapsed		Wait until the bimetal cools		
		Switching spring is broken	End of service life	Replace with a new part		
		Contact has fused because of excessive breaking current		Replace with a new part with a large breaking capacity		
		Insufficient lubricant (grease)		Replace with a new part		
Broken handle		Excessive power during operation		Replace with a new part		
		Excessive external shock				
Poor energizing		Insulation material caught between contacts		Replace with a new part		
		Corrosion due to rainwater, etc.				
		Fusion at conductive section	Excessive breaking current	Replace with a new part with a large breaking capacity		
Annoying operation		Operates under normal load	Incorrect selection (temperature compensation)	Select a different rating		
			Panel is sealed	Ventilate		
		Excessive temperature rise	Loosening at terminal connections	Tighten		
		Applied frequency is incorrect	Incorrect selection (frequency)	Replace with a breaker with the correct frequency		
		Load current contains high levels of high-frequency distortion		Insert a reactor to decrease the distortion factor		
				Replace with a breaker with a high rated current		
		Measuring instrument is reading small measurement values because of distorted current		Select the correct rating by measuring with a true RMS converter		
		Electronic type breaker	Overcurrent indicator LED is ON	Rated current setting is too low		Set the correct rated current
				Rated current selector malfunction		Replace with a new part
		Time-delayed operation when starting		Heat accumulation due to repeated starts	Incorrect selection	Replace with a breaker with a higher rating (replace with a new part)
Starting current is too high						
Long starting time						
Instantaneous operation when starting		Starting rush current is too high		Change the instantaneous setting or replace with a breaker with a higher rating (replace with a new part)		
		Excessive current when Y-Δ starting is selected, excessive current due to reverse operation				
		Rush current during instantaneous restart		Repair or replace the motor		
		Layer short circuit of motor				
		Bimetal reset incomplete after instantaneous tripping				
Abnormal current flow at same time as closing (short-circuit closing)		Inspect the circuit and eliminate the cause				
Short-circuit on power side		Dust has accumulated		Replace with a new part		
		Conductive matter has dropped into power side				
Temperature rise	Terminal temperature is high	Improper tightening	Improper maintenance	Tighten		
		Excessive wear of contacts		Replace with a new part		
	Mold side temperature is high	Complete electromagnetic type being used at a high frequency (400Hz, etc.)		Select a breaker with the correct frequency		
		Load current contains high levels of high-frequency distortion		Insert a reactor to decrease the distortion factor		
		Differences according to each person's sense		Replace with a breaker with a high rated current		
Heating at stud tightening section		Studs are loose	Tighten			
		Contact fault between stud conductor and body terminal	Reassemble the stud			
		Grooves to reduce overcurrent heating not machined on steel mounting plate of rear connection type (400A frame or more)		Machine grooves to reduce overcurrent heating		
No operation	No tripping at overcurrent	Selected rated current is too high		Replace with a breaker with a lower rating (replace with a new part)		
		Applied frequency is incorrect	Incorrect selection (frequency)	Replace with a breaker with the correct frequency		
		An upstream breaker has instantaneously tripped	The instantaneous tripping current of an upstream breaker is too low	Lower the instantaneous tripping current Raise the instantaneous tripping current of the upstream breaker (In the case of breakers without an adjustment function, replace with a new part with a different rating)		
Does not operate with breaker tester or adjuster (Electronic type breaker)	Overcurrent indicator LED does not turn ON	The battery of the breaker tester or adjuster is spent		Replace the battery of the breaker tester or adjuster		
	Overcurrent indicator LED turns ON and then OFF after specified time, but does not trip	Tripping mechanism is faulty		Replace with a new part		
		Electronic circuit failure				

Remarks: 1. Since the related equipment of No-Fuse Circuit Breakers, Earth Leakage Circuit Breakers are nonrepairable, we are not able to provide repairing services.



**(2) Troubleshooting for leakage operation section**

Fault state		Cause	Countermeasures and Actions
Annoying operation	Operates simultaneously with closing (The leakage mechanism operates, such as the leakage indication button pops out)	The wiring is long creating a large ground electrostatic capacity, and causes a leakage current flow	Change the rated sensitivity current or install the ELCB near the load
		ELCB units are being used in parallel, or is incorrectly connected with a neutral wire, etc.	Use the correct wiring
	Operates during use	An excessive surge, such as inducted lightning, has infiltrated the unit	Install a surge absorber, etc., near the circuit
		Induction noise from a nearby large current bus, etc., has infiltrated the unit	Avoid sources of noise
Operation errors	Leakage operation occurs when the test button is pressed, etc., but there is not indication	LED is faulty or is at end of service life	Replace with a new part
		The indicator button is improperly adjusted and does not protrude	Replace with a new part
No operation	No operation takes place when the test button is pressed	Electronic circuit section is faulty	Replace with a new part
		Voltage is not applied	Apply the specified voltage
		Contact continuity is faulty	Remove the foreign matter from the contact

Remarks: 1. When using a transceiver, use at least 1m away from the electronic MCCB and ELCB.

**(3) Troubleshooting for accessories**

Fault state		Cause		Countermeasures and Actions
NFM NVM (Electric operation device)	Operation disabled	Operation power voltage has dropped	Operation circuit wire capacity is insufficient	Use a larger operation circuit wire
			Operation power capacity is insufficient	Improve the operation power
		Resistor or motor is burned	Excessive continuous operation	Return for repairs (motor replacement)
		Connection is incorrect		Use the correct wiring
	Applied voltage is incorrect		Apply the correct operation voltage	
	Continuous idling	ON and OFF circuits are operating simultaneously, operation is mistaken		Provide an interlock at the pushbutton
		For the self-holding type, the auxiliary switch contact is used for automatic reset		Use the alarm switch contact for the automatic reset contact
One idle run when closing	Voltage ripping in the OFF state, or tripping caused by undervoltage		Turn OFF once to reset, and then turn ON again	
	Breaker itself has automatically cut-off and tripped			
UVT (Undervoltage tripping device)	Closing disabled	Applied frequency or voltage is incorrect		Improve the power
		Doesn't attract	voltage drop is large	Improve the voltage
	Doesn't trip even when voltage is absent	Breaker's tripping mechanism is faulty		Return for repairs
SHT (Shunt tripping device)	Doesn't trip	Insufficient voltage	Operation voltage has dropped	Improve the power
			Applied voltage is incorrect	Improve the power
		Coil is burnt	Coil is continuously excited	Return for repairs (coil replacement, installation of burn prevention auxiliary coil)
			Operation voltage has dropped causing continuous excitation	Return for repairs (coil replacement), improve power
			Burn preventing auxiliary contact is faulty	Return for repairs (coil replacement, contact repair)
			Abnormal voltage is applied	Return for repairs (coil replacement)
AL (Alarm switch) AX (Auxiliary switch) EAL (Earth leakage alarm contact) TBM (Test button module) PAL (Pre-alarm)	Malfunction	Contact fault caused by overcurrent		Return for repairs
		Incorrect connection	Connection mistaken during installation	Refer to nameplate and correct the wiring
		Microload	Incorrect selection	Return for repairs (replacement with type for microloads)
		Loose mounting screws	Insufficient tightening Vibration during transportation	Return for repairs (readjustment)

# 8 Handling and Maintenance

## (4) Cases of unnecessary ELCB operation

Even if the ELCB is not faulty, there may be a problem in the circuit which causes frequent operation or instantaneous operation at closing. Refer to the following section and incorporate it as part of the circuit inspection and troubleshooting.

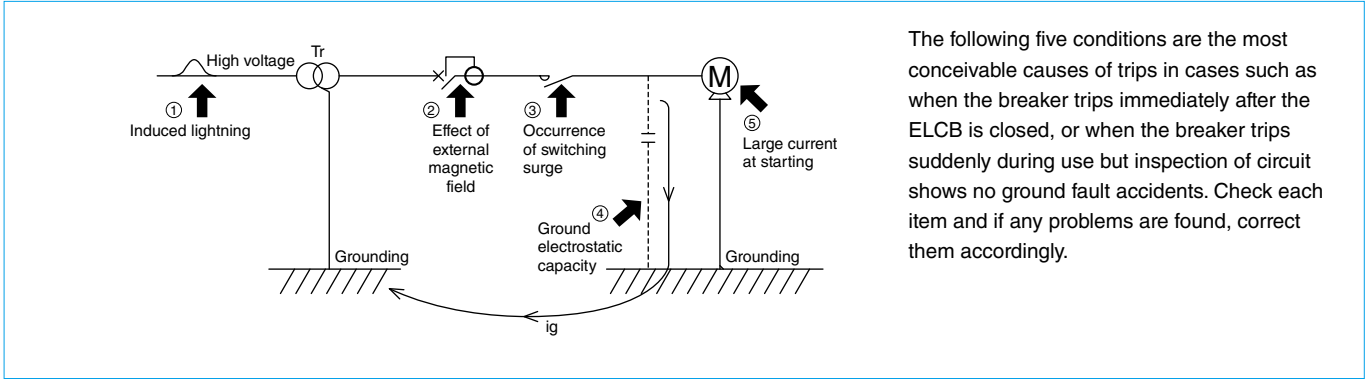

The following five conditions are the most conceivable causes of trips in cases such as when the breaker trips immediately after the ELCB is closed, or when the breaker trips suddenly during use but inspection of circuit shows no ground fault accidents. Check each item and if any problems are found, correct them accordingly.

Cause	Countermeasures
1 Induction lightning	All models incorporate a non-operating shock structure and should sufficiently withstand 7kV (JIS Standards), so unnecessary operation should not occur.
2 External magnetic field	The ZCT is equipped with a magnetic shield, and is not affected easily. However, the breaker could operate if there are large current buses reaching several thousand amperes near the ELCB, or if there is a short-circuit fault in nearby circuit. Separate the ELCB from the large current bus wires by at least 10cm.
3 Switching surge	All models incorporate a non-operating shock structure and should not operate unnecessarily. However if there is a time lag in the closing time of each pole in the magnetic switch, unnecessary operation could occur due to the relation of the ground electrostatic capacity.
4 Effect of ground electrostatic capacity	If the wires are stored in a metal conduit or metal duct wiring, the ground electrostatic capacity will increase compared to other wiring methods. This may cause the leakage current to constantly increase. If the magnetic switch chatters, etc., the leakage current may become temporarily unbalanced thus reaching a leakage current equivalent to the sensitivity current and causing unnecessary operation. Review the following matters in this case. <ol style="list-style-type: none"> <li>1) Shorten the load circuit line, or install the ELCB near the load (device) being used. (Install in a branch circuit.)</li> <li>2) Lead the control circuit for the control device, etc., from the power on the ELCB side.</li> <li>3) If the above measures are difficult or if they cause further unnecessary operation, reconsider the selected ELCB rated sensitivity current.</li> </ol>
5 Equilibrium properties caused by large current at starting	The ZCT is made of high-grade permalloy, a material with Ni as its main element and which has outstanding residual magnetic characteristics. The periphery of the ZCT is covered with material having outstanding magnetic characteristics, creating a complete magnetic shield. This suppresses the effect of residual currents to small, and it has excellent equilibrium characteristics. Therefore, even if the starting inrush current of the motor is several to several tens of times the rated current flowing through the breaker, the earth leakage tripping function will not cause unnecessary operation. When using a compatible ZCT such as a earth leakage relay, This property changes when the primary conductor near the ZCT is bent. When penetrating a primary conductor of 300A or more, make a straight line of 30cm or more on one side.

# 9

## Appendix

1) Handle Operation Angle Dimensions .....	258
2) MCCB Trip Button, Instantaneous Adjustment Dial Drilling and Terminal Cover Mounting Hole Dimensions .....	259
3) ELCB Button and Switch Dimensions .....	260
4) List of Product Weights .....	261
5) Switching the Adjustable Items .....	262
6) Breaker Mounting Screw Dimensions .....	265
7) List of Mold Surface Temperature-rise Values.....	266
8) Ordering Information .....	267
9) Index .....	269
10) MELSELECT™ .....	270
11) Low-Voltage Products Website.....	271
12) Service Network .....	272

## 1. Handle Operation Angle Dimensions

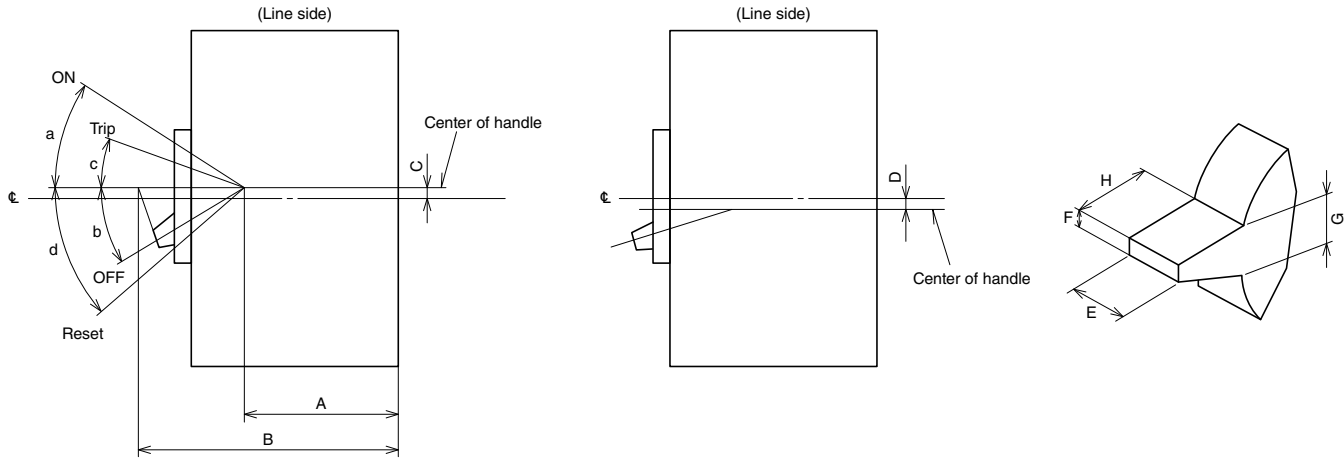

Table of dimension variations

Class	Model		Operation angle (°)				Dimensions (mm)								
			ON	OFF	Trip	Reset	A	B	C	D	E	F	G	H	
	MCCB, MCB	ELCB, RCCB, RCBO	a	b	c	d	A	B	C	D	E	F	G	H	
C S H	NF50-SVFU	NV50-SVFU	12	20	4	27	55	90	13	-	8	5	5	14	
	NF32-SV, NF63-HDV NF63-CV, NF63-SV, NF63-HV NF125-CV, NF125-SV, NF125-HV NF100-CVFU, NF125-SVU, NF125-HVU	NV32-SV NV63-CV, NV63-SV, NV63-HV NV125-CV, NV125-SV, NV125-HV NV100-CVFU, NV125-SVU, NV125-HVU	15	19	5	21	40	90	2	-	12	7	7	17	
	NF125-SEV, NF125-HEV NF250-CV, NF250-SV, NF250-HV NF250-SEV, NF250-HEV NF250-SEV/HEV with MDU NF125-HDVA NF250-SGV, NF250-LGV, NF250-HGV NF125-SGV, NF125-LGV, NF125-HGV NF160-SGV, NF160-LGV, NF160-HGV NF250-CVU, NF250-SVU, NF250-HVU	NV125-SEV, NV125-HEV NV250-CV, NV250-SV, NV250-HV NV250-CVU, NV250-SVU, NV250-HVU NV250-SEV, NV250-HEV	15	19	5	21	40	92	2	-	12	7	7	19	
	NF100-SRU	NV100-SRU	20	35.5	5	44.5	71	96	13	-	10	5	8.5	16.5	
	NF100-HRU	NV100-HRU	20	35.5	5	44.5	71	102	13	-	10	5	8.5	16.5	
	NF400-CW	NV400-CW	16.5	10	6.5	14.5	49	134	6.5	-	32.5	14.5	15.5	25	
	NF400-SW/SEW/HEW/REW NF630-CW/SW/SEW/HEW/REW NF400-SWU/HWU	NV400-SW/SEW/HEW NV630-CW/SW/SEW/HEW	16.5	10	6.5	14.5	49	155	6.5	-	32.5	13.5	15.5	46	
	NF400-HDW	-	16.5	10	6.5	14.5	55	161	6.5	-	32.5	13.5	15.5	46	
	NF800-CEW/SDW/SEW/HEW/REW NF800-SEW/HEW with MDU NF630-SWU/HWU	NV800-SEW/HEW	16.5	10	6.5	14.5	49	155	6.5	-	32.5	13.5	15.5	46	
	NF800-HDW	-	16.5	10	6.5	14.5	55	161	6.5	-	32.5	13.5	15.5	46	
	NF1000-SEW, NF1250-SEW NF1600-SEW	-	18	12	6	17	84	190	-	4	41.5	13.5	15	36.5	
	R U	NF125-RGV, NF250-RGV	-	15	19	5	21	40	92	2	-	12	7	7	19
		NF125-UV	-	15	19	5	21	40	92	-	29	12	7	7	17
		NF250-UV	-	15	19	5	21	40	92	-	35	12	7	7	19
		NF400-UEW	-	16.5	10	6.5	14.5	146	252	-	13.5	32.5	13.5	15.5	46
		NF400-UEW(4P), NF800-UEW	-	16.5	10	6.5	14.5	146	252	-	17	32.5	13.5	15.5	46
	FAU	NF30-FAU, NF50-FAU	NV30-FAU, NV50-FAU	30	21	1	31	53.5	73.5	5	-	8	5	6	13
	FHU	NF50-FHU	NV50-FHU	21	29	1	31	57	76	15.5	-	8.5	4.5	6	13
NF100-FHU		NV100-FHU	21	29	1	31	57	76	12.5	-	8.5	4.5	6	13	
BH-D6*1, BH-D10*1		-	41	36	-	-	63	76	9	-	-	-	-		
BH	BH-DN*1	-	42	48	-	-	63	76	10	-	17	4	9.5	12	
	KB-D	-	41	48	-	-	63	76	9	-	-	-	-		
	-	BV-D*1	42	40	-	-	61	76	10	-	14	4	-		
-	BV-DN*1, BV-DN6*1	42	48	-	-	63	76	10	-	17	4	-			

Note \*1 Trip is the same as the OFF position. Resetting is not required.

## 2. MCCB Trip Button, Instantaneous Adjustment Dial Drilling and Terminal Cover Mounting Hole Dimensions

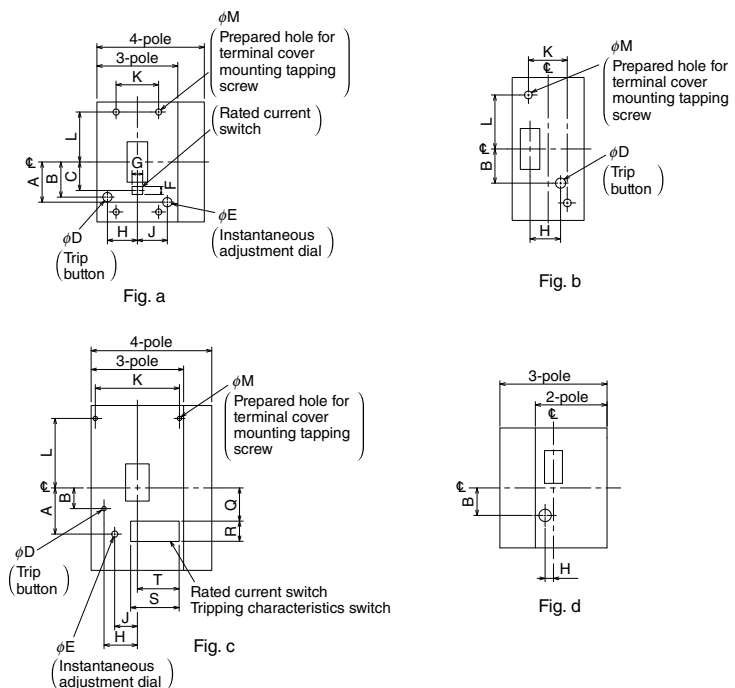

Table of dimension variations

Model	Number of poles	Fig.	A	B	C	φD	φE	F	G	H	J	K	L	φM	N	P	Q	R	S	T
NF50-SVFU	2, 3	d	-	14	-	6.5	-	-	-	4	-	-	-	-	-	-	-	-	-	-
NF32-SV, NF63-CV	2	b	-	20	-	6.5	-	-	-	21	-	-	-	-	-	-	-	-	-	-
NF63-SV, NF63-HV NF63-HDV	3, 4	a	-	20	-	6.5	-	-	-	29	-	-	-	-	-	-	-	-	-	-
NF125-CV, NF125-SV, NF125-HV	2	b	-	20	-	6.5	-	-	-	21	-	-	-	-	-	-	-	-	-	-
NF100-CVFU, NF125-SVU, NF125-HVU	3, 4	a	-	20	-	6.5	-	-	-	37	-	-	-	-	-	-	-	-	-	-
NF125-UV	2, 3, 4	a	-	20	-	6.5	-	-	-	37	-	-	-	-	-	-	-	-	-	-
NF125-SEV, NF125-HEV, NF250-SV, NF250-HV NF125-SGV, NF125-LGV, NF125-HGV NF160-SGV, NF160-LGV, NF160-HGV NF250-SGV, NF250-LGV, NF250-HGV NF250-CVU, NF250-SVU, NF250-HVU, NF250-UV	2, 3, 4	a	-	20	-	6.5	-	-	-	44	-	-	-	-	-	-	-	-	-	-
NF250-SEV, NF250-HEV	3, 4	a	-	20	-	6.5	-	-	-	44	-	-	-	-	-	-	-	-	-	-
NF125-RGV	2, 3	a	-	20	-	6.5	-	-	-	44	-	-	-	-	-	-	-	-	-	-
NF250-RGV	2, 3	a	-	20	-	6.5	-	-	-	44	-	-	-	-	-	-	-	-	-	-
NF50-FHU	2	a	-	9.5	-	4	-	-	-	15	-	-	-	-	-	-	-	-	-	-
	3	a	-	9.5	-	4	-	-	-	27.5	-	-	-	-	-	-	-	-	-	-
NF30-FAU, NF50-FAU	2	a	-	11	-	4	-	-	-	0	-	-	-	-	-	-	-	-	-	-
	3	a	-	11	-	4	-	-	-	10	-	-	-	-	-	-	-	-	-	-
NF100-SRU, NF100-HRU	2	a	-	2.5	-	4	-	-	-	18.5	-	-	-	-	-	-	-	-	-	-
	3	a	-	2.5	-	4	-	-	-	31	-	-	-	-	-	-	-	-	-	-
NF100-FHU	3	a	-	12.5	-	4	-	-	-	27.5	-	-	-	-	-	-	-	-	-	-
NF400-CW	2, 3	c	-	30.5	-	6.5	-	-	-	51.5	-	125	110.5	3.5	-	-	-	-	-	-
NF400-SW, NF400-SWU, NF400-HWU	2, 3	c	-	30.5	-	6.5	-	-	-	51.5	-	125	110.5	3.5	-	-	-	-	-	-
	4	c	-	30.5	-	6.5	-	-	-	51.5	-	125	110.5	3.5	-	-	-	-	-	-
NF400-SEW, NF400-HEW, NF400-REW	3	c	-	30.5	-	6.5	-	-	-	51.5	-	125	110.5	3.5	-	-	53	30	74	63.5
	4	c	-	30.5	-	6.5	-	-	-	51.5	-	125	110.5	3.5	-	-	53	30	74	63.5
NF400-UEW	3	c	-	50.5	-	6.5	-	-	-	51.5	-	125	130.5	3.5	-	-	53	30	74	63.5
	4	c	-	54	-	6.5	-	-	-	78.5	-	156	152	3.5	-	-	76.5	30	74	98.5
NF400-HDW	3	c	-	30.5	-	6.5	-	-	-	51.5	-	125	110.5	3.5	-	-	-	-	-	-
	4	c	-	30.5	-	6.5	-	-	-	51.5	-	125	110.5	3.5	-	-	-	-	-	-
NF630-CW	2, 3	c	-	30.5	-	6.5	-	-	-	51.5	-	125	110.5	3.5	-	-	-	-	-	-
NF630-SW	2, 3	c	-	30.5	-	6.5	-	-	-	51.5	-	125	110.5	3.5	-	-	-	-	-	-
	4	c	-	30.5	-	6.5	-	-	-	51.5	-	125	110.5	3.5	-	-	-	-	-	-
NF630-SEW, NF630-HEW, NF630-REW	3	c	-	30.5	-	6.5	-	-	-	51.5	-	125	110.5	3.5	-	-	53	30	74	98.5
	4	c	-	30.5	-	6.5	-	-	-	51.5	-	125	110.5	3.5	-	-	53	30	74	98.5
NF800-CEW, NF800-SEW, NF800-HEW, NF800-REW	3	c	-	30.5	-	6.5	-	-	-	78.5	-	86	128.5	3.4	-	-	53	30	74	98.5
	4	c	-	30.5	-	6.5	-	-	-	78.5	-	156	128.5	3.4	-	-	53	30	74	98.5
NF800-SDW, NF630-SWU, NF630-HWU	2, 3	c	74	30.5	-	6.5	10	-	-	78.5	57	86	128.5	3.4	-	-	-	-	-	-
	4	c	74	30.5	-	6.5	10	-	-	78.5	57	156	128.5	3.4	-	-	-	-	-	-
NF800-UEW	3	c	-	54	-	6.5	-	-	-	78.5	-	86	152	3.4	-	-	76.5	30	74	98.5
	4	c	-	54	-	6.5	-	-	-	78.5	-	156	152	3.4	-	-	76.5	30	74	98.5
NF800-HDW	3	c	-	30.5	-	6.5	-	-	-	78.5	-	86	128.5	3.4	-	-	-	-	-	-
	4	c	-	30.5	-	6.5	-	-	-	78.5	-	156	128.5	3.4	-	-	-	-	-	-
NF1000-SEW, NF1250-SEW	3	c	-	70	-	6	-	-	-	56.5	-	199	178.5	3.4	-	-	130	30	74	89
NF1600-SEW	4	c	-	70	-	6	-	-	-	56.5	-	269	178.5	3.4	-	-	130	30	74	89

Remarks: 1. The 4-pole part is available for the S and H Series 50A frame to 1600A frame (excluding NF400-REW, NF630-REW and NF800-REW).  
 2. The 2-pole part for NF250-CV and larger is the same as the 3-pole part. (Including NF125-HV.)  
 3. The terminal cover mounting hole shows the case for the screwed type. The breaker mounting hole is used to mount the one-touch terminal cover. Refer to the respective dimension drawings.  
 4. The K dimensions are divided down the breaker center.

## 3. ELCB Button and Switch Dimensions

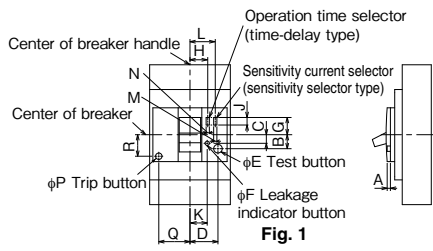

Fig. 1

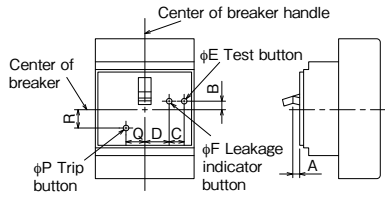

Fig. 2

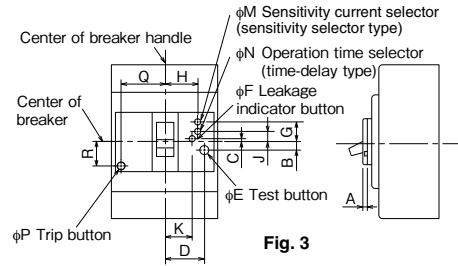

Fig. 3

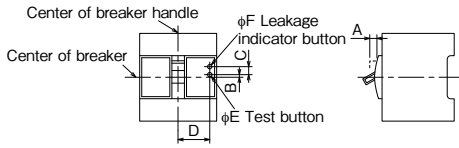

Fig. 4

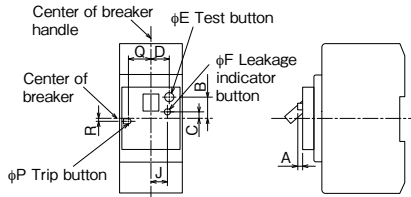

Fig. 5

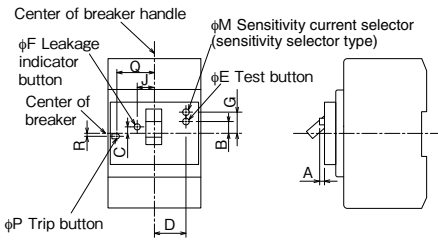

Fig. 6

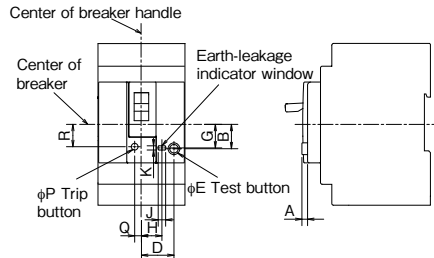

Fig. 7

### Table of dimension variations

Model	Reference drawing	Variable dimensions (mm)																	
		A		B	C	D	E	F	G	H	J	K	L	M	N	P	Q	R	
		Test button	Indicator button																
NV50-SVFU	Fig. 7	3.5	-	15	-	20	7	-	14.5	12.5	4.5	2.5	-	-	-	4	4	14	
NV32-SV	Fig. 1	-	-	13	8	26.5	9.5	4	-	-	-	16	-	-	-	6	29	20	
NV63-CV, NV63-SV, NV63-HV									16	-	7		23.5	3	-				
NV125-CV, NV125-SV, NV125-HV	Fixed type	Fig. 1	-	13	8	26.5	9.5	4	-	-	-	16	-	-	-	6	37	20	
	Selector type								16	17	7		24	3	3				
	Time-delay type								-	-	-		-	-	-				
NV250-CV, NV250-SV, NV250-HV	Fixed type	Fig. 1	3	4	13	8	34	9.5	4	-	-	-	23.5	-	-	6	44	20	
	Selector type									16	-	7		31	3				-
	Time-delay type									16	24	7		31	3				3
NV125-SEV, NV125-HEV	Fixed type	Fig. 1	-	10.5	8	32	9.5	4	-	-	-	23.5	-	-	6	44	20		
	Selector type								16	-	7		31	3				-	
	Time-delay type								16	24	7		31	3				3	
NV50-FHU	2P	Fig. 2	4	4	6.5	9	9.5	4	4	-	-	-	-	-	-	-	-	-	
3P	9				22	4													
NV100-FHU	3P	Fig. 2	4	4	3.5	9	22	4	4	-	-	-	-	-	-	-	-	-	
NV30-FAU, NV50-FAU	2P	Fig. 4	0	2.5	3	6	15	3	3	-	-	-	-	-	-	-	-	-	
	3P						25												
NV100-SRU	2P	Fig. 5	3.5	3	17	5	15	7.5	4.5	-	13.5	-	-	-	4	18	2.5		
NV100-SRU/HRU	3P				Fig. 6		9.5			25.5				17.5				5.5	30.5
NV400-CW (*1)	Fixed type	Fig. 3	3	3	(2.3)	14.6	43.5	9.5	5	-	43.5	-	43.5	-	6.5	51.5	30.5		
	Selector type									30.6				5.5				5.5	
	Time-delay type									30.6				22.6				5.5	
NV400-SEW, NV400-HEW	Fixed type	Fig. 3	3	3	(2.3)	14.6	43.5	9.5	5	-	43.5	-	43.5	-	6.5	51.5	30.5		
	Selector type									30.6				5.5				5.5	
	Time-delay type									30.6				22.6				5.5	
NV800-SEW, NV800-HEW	Fixed type	Fig. 3	3	3	(2.3)	14.6	54.1	9.5	5	30.6	54.1	-	54.1	-	6.5	78.5	30.5		
	Time-delay type									30.6				22.6				5.5	

Note \*1 Dimensions shown in parentheses apply to minus direction.

# 4. List of Product Weights

## MCCB

(Kg)

Model	Item	Breaker body											Accessories (weight of only accessories)							
		Front connection type				Rear connection type				Plug-in type (including plug-in frame)			Electric operated type	Boxed type			Operation handle			Mechanical interlock (MI)
		1P	2P	3P	4P	1P	2P	3P	4P	2P	3P	4P		S	I	W	F type	V type	C type	
C.S.H.MB	NF32-SV	-	0.45	0.65	-	-	0.55	0.8	-	0.8	1.2	-	-	1.5	5.0	10.2	0.4	0.45	-	0.17
	NF63-CV (rated current 50A or less)	-	0.45	0.65	-	-	0.55	0.8	-	0.8	1.2	-	-	1.5	5.0	10.2	0.4	0.45	-	0.17
	NF63-CV (rated current 60A, 63A)	-	0.5	0.7	-	-	0.6	0.85	-	0.85	1.25	-	-	1.5	5.0	10.2	0.4	0.45	-	0.17
	NF63-SV, NF63-HV (rated current 50A or less)	-	0.5	0.7	0.9	-	0.6	0.85	1.1	0.85	1.25	1.5	-	1.5	5.0	10.2	0.4	0.45	-	0.17
	NF63-SV, NF63-HV (rated current 60A, 63A)	-	0.55	0.75	1.0	-	0.65	0.9	1.2	0.9	1.3	1.6	-	1.5	5.0	10.2	0.4	0.45	-	0.17
	NF125-CV	-	0.6	1.0	-	-	1.0	1.5	-	1.2	1.9	-	1.3	1.8	5.1	10.2	0.4	0.45	-	0.17
	NF125-SV	-	0.7	0.95	1.3	-	1.1	1.5	2.0	1.3	1.9	2.4	1.3	1.8	5.1	10.2	0.4	0.45	-	0.17
	NF125-HV	-	0.6	1.0	1.2	-	1.0	1.5	1.9	1.2	1.9	2.3	1.3	1.8	5.1	10.5	0.4	0.45	-	0.17
	NF125-SEV	-	-	1.7	2.2	-	-	2.2	2.9	-	2.6	3.3	1.3	6.8	8.7	13.5	0.5	0.55	-	0.17
	NF125-HEV	-	-	1.7	2.2	-	-	2.2	2.9	-	2.6	3.3	1.3	6.8	8.7	13.5	0.5	0.55	-	0.17
	NF250-CV	-	1.3	1.5	-	-	1.7	2.2	-	3.1	3.4	-	1.3	6.8	8.7	13.5	0.5	0.55	-	0.17
	NF250-SV	-	1.4	1.6	2.0	-	1.8	2.3	3.0	3.2	3.5	4.5	1.3	6.8	8.7	13.5	0.5	0.55	-	0.17
	NF250-HV	-	1.4	1.6	2.0	-	1.8	2.3	3.0	3.2	3.5	4.5	1.3	6.8	8.7	13.5	0.5	0.55	-	0.17
	NF250-SEV	-	-	1.7	2.2	-	-	2.4	3.2	-	3.6	4.7	1.3	6.8	8.7	13.5	0.5	0.55	-	0.17
	NF250-HEV	-	-	1.7	2.2	-	-	2.4	3.2	-	3.6	4.7	1.3	6.8	8.7	13.5	0.5	0.55	-	0.17
	NF125-SGV	-	1.4	1.6	2.0	-	1.8	2.3	3.0	3.2	3.5	4.5	1.3	6.8	8.7	13.5	0.5	0.55	-	0.17
	NF125-LGV	-	1.4	1.6	2.0	-	1.8	2.3	3.0	3.2	3.5	4.5	1.3	6.8	8.7	13.5	0.5	0.55	-	0.17
	NF125-HGV	-	1.4	1.6	2.0	-	1.8	2.3	3.0	3.2	3.5	4.5	1.3	6.8	8.7	13.5	0.5	0.55	-	0.17
	NF160-SGV	-	1.4	1.6	2.0	-	1.8	2.3	3.0	3.2	3.5	4.5	1.3	6.8	8.7	13.5	0.5	0.55	-	0.17
	NF160-LGV	-	1.4	1.6	2.0	-	1.8	2.3	3.0	3.2	3.5	4.5	1.3	6.8	8.7	13.5	0.5	0.55	-	0.17
	NF160-HGV	-	1.4	1.6	2.0	-	1.8	2.3	3.0	3.2	3.5	4.5	1.3	6.8	8.7	13.5	0.5	0.55	-	0.17
	NF250-SGV	-	1.4	1.6	2.0	-	1.8	2.3	3.0	3.2	3.5	4.5	1.3	6.8	8.7	13.5	0.5	0.55	-	0.17
	NF250-LGV	-	1.4	1.6	2.0	-	1.8	2.3	3.0	3.2	3.5	4.5	1.3	6.8	8.7	13.5	0.5	0.55	-	0.17
	NF250-HGV	-	1.4	1.6	2.0	-	1.8	2.3	3.0	3.2	3.5	4.5	1.3	6.8	8.7	13.5	0.5	0.55	-	0.17
	NF400-CW	-	4.4	5.0	-	-	5.7	7.0	-	7.0	8.3	-	-	-	-	-	-	-	-	-
	NF400-SW	-	4.6	5.2	6.8	-	5.9	7.3	9.7	7.2	8.5	11.3	-	-	19	30	-	-	-	-
	NF400-SEW/HEW	-	-	6.0	7.6	-	-	8.1	10.5	-	9.3	12.0	-	-	-	-	-	-	-	-
	NF400-REW	-	-	6.0	-	-	-	8.5	-	-	9.3	-	-	-	-	-	-	-	-	-
	NF630-CW	-	5.2	6.0	-	-	6.5	7.9	-	7.6	9.1	-	-	-	-	-	2.0	-	-	-
	NF630-SW	-	5.4	6.2	8.0	-	6.7	8.1	10.6	7.8	9.3	12.0	-	-	33	30	-	-	-	-
NF630-SEW/HEW	-	-	6.5	8.3	-	-	8.4	10.9	-	9.6	12.3	-	-	-	-	-	-	-	0.45	
NF630-REW	-	-	6.5	-	-	-	8.4	-	-	9.6	-	-	-	-	-	-	-	-	-	
NF800-CEW	-	-	10.9	-	-	-	12.1	-	-	16.3	-	-	-	-	-	-	-	-	-	
NF800-SDW	-	9	-	-	-	10	-	-	-	-	-	-	-	-	-	-	-	-	-	
NF800-SEW/HEW	-	-	10.9	14.2	-	-	12.1	15.8	-	16.3	21.4	-	-	48	70	2.4	-	-	-	
NF800-REW	-	-	10.9	-	-	-	12.1	-	-	16.3	-	-	-	-	-	-	-	-	-	
NF1000-SEW, NF1250-SEW	-	-	23.5	30.7	-	-	23	30.8	-	26.6	35.5	10	-	48	70	3.4	-	-	-	
NF1600-SEW	-	-	34.5	41.2	-	-	30	40.7	-	-	-	-	-	-	-	-	-	-	0.55	
NF125-RGV	-	1.5	1.8	-	-	-	-	-	2.35	2.7	-	1.3	-	-	-	0.5	0.55	-	0.17	
NF250-RGV	-	1.5	1.8	-	-	-	-	-	3.2	3.6	-	1.3	-	-	-	0.5	0.55	-	0.17	
NF125-UV	-	1.35	1.7	1.9	-	-	-	-	2.2	2.4	-	1.3	-	-	-	0.5	0.55	-	0.17	
NF250-UV	-	2.5	2.7	3.7	-	-	-	-	4.2	4.5	-	1.3	-	-	-	0.5	0.55	-	0.17	
NF400-UEW	-	-	16.2	25.4	-	-	18.6	30.7	-	19.8	-	9.0	-	-	-	2.2	-	-	0.45	
NF800-UEW	-	-	27.6	33.7	-	-	31.2	38.4	-	-	-	9.0	-	-	-	2.7	-	-	0.45	
NF63-HDV	-	0.45	0.65	-	-	0.55	0.8	-	-	-	-	-	-	-	-	0.4	0.45	-	-	
HDV (rated current 50A or less)	-	0.45	0.65	-	-	0.55	0.8	-	-	-	-	-	-	-	-	0.4	0.45	-	-	
HDVA	-	-	-	-	-	-	-	-	-	-	-	-	-	-	-	0.5	0.55	-	-	
NF250-HDVA	-	-	-	-	-	-	-	-	-	-	-	-	-	-	-	0.5	0.55	-	-	
HDW	-	-	5.6	7.3	-	-	7.3	9.7	-	-	-	-	-	-	-	2.0	-	-	-	
NF400-HDW	-	-	9.9	13.0	-	-	11.0	14.4	-	-	-	-	-	-	-	2.4	-	-	-	
NF800-HDW	-	-	9.9	13.0	-	-	11.0	14.4	-	-	-	-	-	-	-	2.4	-	-	-	
FA	-	0.14	0.2	-	-	-	-	-	-	-	-	-	-	-	-	-	-	-	-	
NF30-FA, NF30-FAU	-	0.14	0.2	-	-	-	-	-	-	-	-	-	-	-	-	-	-	-	-	
NF50-FA, NF50-FAU	-	0.16	0.22	-	-	-	-	-	-	-	-	-	-	-	-	-	-	-	-	
NF50-FHU	-	0.25	0.37	-	-	-	-	-	-	-	-	-	-	-	-	-	-	-	-	
NF100-FHU	-	-	0.51	-	-	-	-	-	-	-	-	-	-	-	-	-	-	-	-	
BH	-	0.15	0.3	0.45	0.55	-	-	-	-	-	-	-	-	-	-	-	-	-	-	
BH-D6, BH-D10	-	0.15	0.3	0.45	0.55	-	-	-	-	-	-	-	-	-	-	-	-	-	-	
BH-DN	-	-	0.12	-	-	-	-	-	-	-	-	-	-	-	-	-	-	-	-	
KB-D	-	0.09	0.18	0.27	0.36	-	-	-	-	-	-	-	-	-	-	-	-	-	-	
UL	-	-	0.3	0.45	-	-	-	-	-	-	-	-	-	-	-	0.3	0.35	-	-	
NF50-SVUFU	-	-	0.3	0.45	-	-	-	-	-	-	-	-	-	-	-	0.4	0.45	3.2	-	
NF100-CVUFU	-	-	0.6	0.85	-	-	-	-	-	-	-	-	-	-	-	0.4	0.5	3.2	0.17	
NF125-SVU	-	-	0.7	0.95	-	-	-	-	-	-	-	-	-	-	-	0.4	0.5	3.2	0.17	
NF125-HVU	-	-	-	1.0	-	-	-	-	-	-	-	-	-	-	-	0.4	0.5	3.2	0.17	
NF250-CVU/SVU/HVU	-	-	-	1.7	-	-	-	-	-	-	-	-	-	-	-	0.5	0.55	3.4	0.17	
NF100-SRU	-	-	0.5	0.75	-	-	-	-	-	-	-	-	-	-	-	0.4	-	-	-	
NF100-HRU	-	-	0.55	0.8	-	-	-	-	-	-	-	-	-	-	-	0.4	-	-	-	
NF400-SWU/HWU	-	-	-	5.7	-	-	-	-	-	-	-	-	-	-	-	2.0	-	5.3	0.45	
NF630-SWU/HWU	-	-	-	9.6	-	-	-	-	-	-	-	-	-	-	-	2.4	-	5.3	0.45	

## ELCB

(Kg)

Model	Item	Breaker body											Accessories (weight of only accessories)							
		Front connection type			Rear connection type			Plug-in type (including plug-in frame)			Electric operated type	Boxed type			Operation handle			Mechanical interlock (MI)		
		2P	3P	4P	2P	3P	4P	2P	3P	4P		S	I	W	F type	V type	C type			
C.S.H.U.L.FA	NV32-SV	-	0.75	-	-	0.95	-	-	1.35	-	-	-	-	1.5	5.0	10.2	0.4	0.45	-	0.17
	NV63-CV, NV63-SV (rated current 50A or less)	0.7	0.75	-	-	0.8	0.95	-	1.1	1.35	-	-	-	1.5	5.0	10.2	0.4	0.45	-	0.17
	NV63-CV, NV63-SV (rated current 60A, 63A)	0.75	0.8	-	-	0.85	1.0	-	1.15	1.4	-	-	-	1.5	5.0	10.2	0.4	0.45	-	0.17
	NV63-HV (rated current 50A or less)	-	0.75	-	-	0.95	-	-	1.35	-	-	-	-	1.5	5.0	10.2	0.4	0.45	-	0.17
	NV63-HV (rated current 60A, 63A)	-	0.8	-	-	1.0	-	-	1.4	-	-	-	-	1.5	5.0	10.2	0.4	0.45	-	0.17
	NV125-CV	-	1.0	-	-	1.5	-	-	1.9	-	1.3	-	1.3	1.8	5.1	10.2	0.4	0.45	-	0.17
	NV125-SV	-	1.1	1.4	-	-	1.6	2.1	-	2.0	2.5	1.3	1.3	1.8	5.1	10.2	0.4	0.45	-	0.17
	NV125-HV	-	1.1	1.4	-	-	1.6	2.1	-	2.0	2.5	1.3	1.3	1.8	5.1	10.5	0.4	0.45	-	0.17
	NV125-SEV	-	1.9	2.5	-	-	2.4	3.2	-	2.8	3.6	1.3	1.3	6.8	8.7	13.5	0.5	0.55	-	0.17
	NV125-HEV	-	1.9	2.5	-	-	2.4	3.2	-	2.8	3.6	1.3	1.3	6.8	8.7	13.5	0.5	0.55	-	0.17
	NV250-CV	-	1.7	-	-	-	2.4	-	-	3.6	-	1.3	1.3	6.8	8.					

## 5. Switching the Adjustable Items

### (1) Adjustable rated current and tripping characteristics items

Adjustable item		Rated current	LTD tripping characteristics	STD tripping characteristics	Instantaneous tripping characteristics	PAL	Rated sensitivity	Rated Operating time (for time-delay type)	Rated voltage
Applicable model									
MCCB	NF125-SEV/HEV	○	○ (*2)	○ (*2)	○	○ (*1)			
	NF250-SEV/HEV	○	○ (*2)	○ (*2)	○	○ (*1)			
	NF400-SEW/HEW/REW/UEW								
	NF630-SEW/HEW/REW	○	○	○	○	○			
	NF800-CEW/SEW/HEW/REW/UEW								
	NF1000-SEW, NF1250-SEW, NF1600-SEW								
	NF800-SDW, NF630-SWU/HWU				○				
	NF125-SGV/LGV/HGV NF160-SGV/LGV/HGV NF250-SGV/LGV/HGV	○							
ELCB	NV125-SEV/HEV	○	○ (*2)	○ (*2)	○	○ (*1)	○	○	
	NV250-SEV/HEV	○	○ (*2)	○ (*2)	○	○ (*1)	○	○	
	NV400-SEW/HEW								
	NV630-SEW/HEW	○	○	○	○	○	○	○	
	NV800-SEW/HEW								
	NV32-SV, NV63-CV/SV/HV						○		
	NV100-SRU, NV100-HRU								
	NV125-CV/SV/HV/SVU/HVU NV250-CV/SV/HV/SVU/HVU NV400-CW/SW, NV630-CW						○	○	

Notes \*1 Available only for models with pre-alarm module.

\*2 Use the OPERATION CHECK & SETUP UNIT Y-360-V(-VW). Consult Mitsubishi for details.

Remarks: Unless otherwise specified, the electronic breaker is adjusted to the following settings as a default.

- (1) Rated current: maximum value
- (2) LTD tripping characteristics: maximum value
- (3) STD tripping characteristics (current, operating time): maximum value
- (4) Instantaneous tripping characteristics: maximum value
- (5) PAL: minimum value
- (6) Rated sensitivity current: maximum value
- (7) Leakage operation time (for time-delay type): maximum value

(2) Adjusting the rated current and tripping characteristics

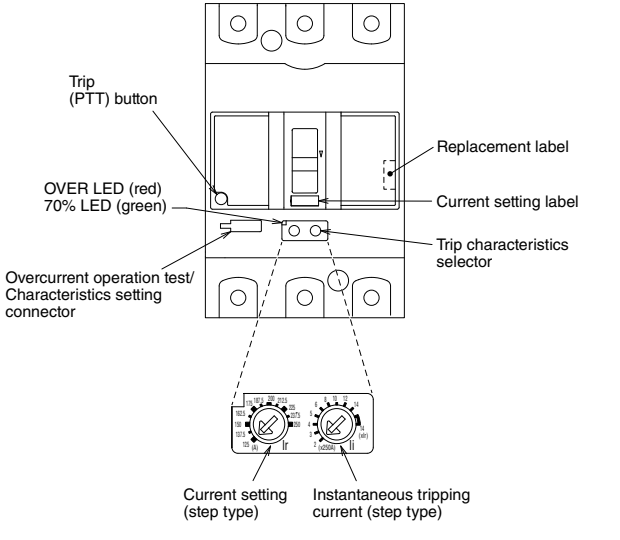
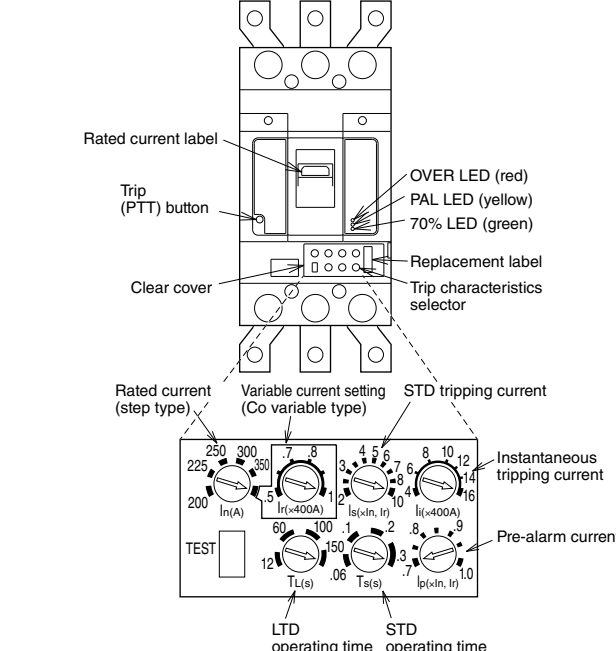
Item	Electronic type	
Application	125 to 250A frame	400 to 1600A frame
Example of selector layout		
Example of making a selection	<p>Turn the handle to OFF before starting the settings.</p> <ol style="list-style-type: none"> <li>① Set the arrow of each characteristic's setting dial to the required scale position. Always set the dial arrow within the bold lines of the setting value. If stopped at the middle, the adjacent setting value may be applied. Use a 0.5mm thick flat-tip screwdriver with a 3mm or less tip width. Turn the screwdriver at 0.05N·m or less.</li> <li>② From the replacement labels, select the rated current label with the same value as the setting value.</li> <li>③ Replace the rated current label.</li> <li>④ Close the cover and tighten the screw.</li> </ol>	<p>Turn the handle to OFF before starting the settings.</p> <ol style="list-style-type: none"> <li>① Open the clear cover.</li> <li>② Set the arrow of each characteristic's setting dial to the required scale position. For values other than instantaneous tripping current and adjustable current settings, which can be adjusted at any time, always set the dial arrow within the bold lines of the setting value. If stopped at the middle, the adjacent setting value may be applied. Use a 0.6mm thick flat-tip screwdriver with a 4.5mm or less tip width. Turn the screwdriver at 0.05N·m or less.</li> <li>③ From the replacement labels, select the rated current label with the same value as the setting value.</li> <li>④ Replace the rated current label.</li> <li>⑤ Close the clear cover.</li> </ol>
Setter and tester	<p><b>In case of 125 to 250A frame</b></p> <p>(Application: Electronic (effective value detection) breaker)</p> <p>The following items can be set and tested using the breaker test and setter Y-360-V(-VW).</p> <ul style="list-style-type: none"> <li>● LTD and STD characteristics settings</li> <li>● Long-term operation test (variable signal)</li> <li>● Short-term operation test (fixed signal) *1</li> <li>● Instantaneous operation test (fixed signal)</li> <li>● Pre-alarm operation test (variable signal) *2</li> </ul> <p>*1. Fixed signal which is 1.5 times the STD trip current. *2. Only for models with pre-alarm module.</p>	<p><b>In case of 400 to 1600A frame</b></p> <p>(Application: Electronic (effective value detection) breaker)</p> <p>The following items can be tested using the tester Y-360-W(-VW).</p> <ul style="list-style-type: none"> <li>● Long-term operation test (variable signal)</li> <li>● Short-term operation test (fixed signal)</li> <li>● Instantaneous operation test (fixed signal)</li> <li>● Pre-alarm operation test (variable signal)</li> </ul>

## (3) Selecting the rated voltage, rated sensitivity and operating time

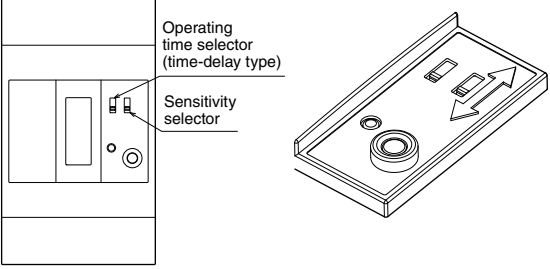
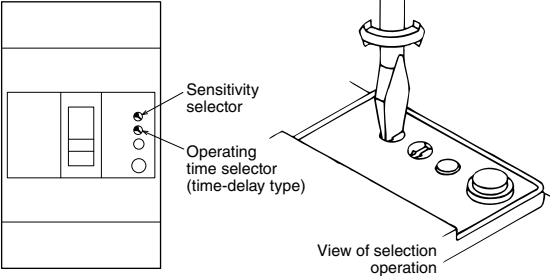
Model	Selector layout	Voltage selection	Sensitivity and operation time selection
ELCB 3-step sensitivity selector type		Use for the circuit voltage within the rated voltage.	Turn the handle to OFF before changing the selection.
		Use for the circuit voltage within the rated voltage.	Turn the handle to OFF before changing the selection.

## 6. Breaker Mounting Screw Dimensions

### ■ MCCB • MCB

Class	Model	Hole depth A	Wood screw (round wood screw) for front connection	Front connection type	Rear connection type	Plug-in type	Required quantity per unit				
							1P	2P	3P	4P	
C • S • H	NF50-SVFU	56	–	M4x0.7x65 (note)	–	–	–	2	2	–	
	NF32-SV, NF63-CV, NF63-SV, NF63-HV NF125-CV, NF125-SV, NF125-HV NF100-CVFU, NF125-SVU NF125-HVU	45	4.1x58	M4x0.7x55	M4x0.7x55	M4x0.7x55	–	2	2	4	
	NF125-SEV, NF125-HEV NF250-CV, NF250-SV, NF250-HV NF250-SEV, NF250-HEV NF250-CVU, NF250-SVU, NF250-HVU NF125-SGV, NF125-LGV, NF125-HGV NF160-SGV, NF160-LGV, NF160-HGV NF250-SGV, NF250-LGV, NF250-HGV	45	4.1x58	M4x0.7x55	M4x0.7x55	M4x0.7x55 M4x0.7x73	–	2 (For plug-in type 4)	2	4	
	NF400-CW, NF400-SW NF400-SWU, NF400-HWU	47	–	M6x60	M6x72	M6x72	–	4	4	4	
	NF400-SEW, NF400-HEW, NF400-REW NF630-CW, NF630-SW, NF630-SEW NF630-HEW, NF630-REW	59	–	M6x72	M6x85	M6x85	–	4	4	4	
	NF800-CEW, NF800-SW NF800-HEW, NF800-REW NF630-SWU, NF630-HWU	15	–	M6x35	M6x40	M6x35	–	4	4	4	
	NF1000-SEW, NF1250-SEW	18.5	–	M8x40	M8x40	M8x40	–	4	4	4	
	NF1600-SEW	18.5	–	M8x40	M8x40	–	–	4	4	4	
	R • U	NF125-RGV NF250-RGV	45	–	M4x0.7x55	M4x0.7x55	M4x0.7x55	–	2	2	–
		NF125-UV, NF250-UV	45/61	–	M4x0.7x55/73	M4x0.7x55/73	M4x0.7x55/73	–	4	4	–
		NF125-UV (4P), NF250-UV (4P)	45	–	M4x0.7x55	M4x0.7x55	M4x0.7x55	–	2	2	4
		NF400-UEW (3P)	47/156	–	M6x65/174	M6x72/181	M6x72/181	–	–	4	–
NF400-UEW (4P), NF800-UEW		15/112	–	M6x35/132	M6x40/137	M6x35/132	–	–	4	6	
BH	BH-D6	–	–	–	–	–	–	–	–	–	
	BH-DN	–	–	–	–	–	–	–	–	–	
	KB-D	–	–	–	–	–	–	–	–	–	
	BH-D10	–	–	–	–	–	–	–	–	–	
FA	NF30-FAU, NF50-FAU	43	–	M4x0.7x50 (note)	Front-plate Mounting M5x0.8x30	–	–	2	2	–	
FH	NF50-FHU	40	–	M4x0.7x50 (note)	–	–	–	2	2	–	
	NF100-FHU	49	–	M4x0.7x60 (note)	–	–	–	–	2	–	
CP	CP30-BA CP30-HU	5	–	M4x0.7x10 (note)	–	–	2	2	2	–	

Remarks: 1. The mounting shown in the  sections are enclosed with the MCCB. The mounting screws for the plug-in connection are enclosed with the plug-in terminal block. All other mounting screws must be prepared by the user.

- All mounting screws other than the hexagon socket bolts and hexagon bolts are P-type panhead screws.
- For models with two types of mounting screws, the screw length differs on the supply side and load side.
- The plug-in type is not available for NF800-UEW.

Note For the P-type panhead screw, use a type with a spring washer and flat washer (small round) combination, or a P-type panhead screw with spring washer and flat washer.

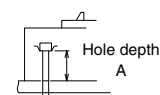

### ■ ELCB • RCCB • RCBO

Class	Model	Hole depth A	Wood screw (round wood screw) for front connection	Screw for steel plates (P-type panhead screw)			Required quantity per unit		
				Front connection type	Rear connection type	Plug-in type	2, 3P	4P	
NV	NV50-SVFU	56	–	M4x0.7x65 (note)	–	–	2	–	
	NV32-SV, NV63-CV, NV63-SV, NV63-HV NV125-CV, NV125-SV, NV125-HV NV100-CVFU, NV125-SVU, NV125-HVU	45	4.1x58	M4x0.7x55	M4x0.7x55	M4x0.7x55	2	4	
	NV125-SEV, NV125-HEV NV250-CV, NV250-SV, NV250-HV NV250-SEV, NV250-HEV, NV250-CVU, NV250-SVU, NV250-HVU	45	4.1x58	M4x0.7x55	M4x0.7x55	M4x0.7x55 M4x0.7x73	2 (For plug-in type 4)	4	
	NV30-FAU, NV50-FAU	43	–	M4x0.7x50 (note)	Front-plate Mounting M5x0.8x30	–	–	2	–
	NV50-FHU	40	–	M4x0.7x50 (note)	–	–	–	2	–
	NV100-FHU	49	–	M4x0.7x60 (note)	–	–	–	2	–
	NV400-CW, NV400-SW NV400-SEW, NV400-HEW NV630-CW, NV630-SW, NV630-SEW NV630-HEW	59	–	M6x72	M6x85	M6x85	4	4	
	NV800-SEW, NV800-HEW	15	–	M6x35	M6x40	M6x35	4	4	
	BV	BV-D	–	–	–	–	–	–	–
		BV-DN	–	–	–	–	–	–	–

Remark: 1. The mounting shown in the  sections are enclosed with the ELCB.

Note For the P-type panhead screw, use a type with a spring washer and flat washer (small round) combination, or a P-type panhead screw with spring washer and flat washer.

## 7. List of Mold Surface Temperature-rise Values

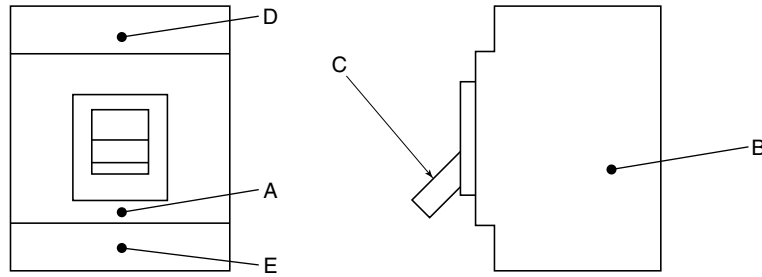

### MCCB

Model	Conducting current	Measurement point				
		Cover surface (A)	Base side (B)	Handle (C)	Line terminal (D)	Load terminal (E)
NF32-SV	32A	14	38	12	36	37
NF63-CV	63A	15	42	14	39	44
NF63-SV	63A	15	39	12	41	44
NF63-HV	63A	15	42	12	41	49
NF125-CV	125A	13	29	9	43	42
NF125-SV	125A	14	32	10	44	40
NF125-HV	125A	16	33	11	49	42
NF250-CV	250A	19	35	13	46	45
NF250-SV	250A	20	36	13	47	45
NF250-HV	250A	20	36	13	49	46
NF125-SGV	125A	20	35	13	42	49
NF250-SGV	250A	20	36	13	49	50
NF160-SGV	160A	20	35	13	40	44
CP30-BA	30A	15	31	15	39	20

Model	Conducting current	Measurement point				
		Cover surface (A)	Base side (B)	Handle (C)	Line terminal (D)	Load terminal (E)
NF400-CW	400A	16	25	16	47	37
NF400-SW	400A	20	27	10	46	37
NF400-SEW	400A	14	22	9	35	31
NF400-HEW	400A	14	23	8	34	32
NF400-REW	400A	15	23	9	35	32
NF400-UW	400A	19	28	13	42	33
NF630-CW	630A	23	32	15	52	52
NF630-SW	630A	23	33	16	54	52
NF630-SEW	630A	22	31	14	51	45
NF630-HEW	630A	20	31	13	50	44
NF630-REW	630A	21	31	13	51	44
NF800-CEW	800A	21	30	13	45	40
NF800-SDW	800A	18	28	12	46	44
NF800-SEW	800A	21	30	12	45	41
NF800-HEW	800A	22	31	12	47	42
NF800-REW	800A	21	30	13	46	42
NF800-UW	800A	25	35	16	51	46

### ELCB

Model	Conducting current	Measurement point				
		Cover surface (A)	Base side (B)	Handle (C)	Line terminal (D)	Load terminal (E)
NV32-SV	32A	15	35	11	36	41
NV63-CV	63A	17	32	13	43	41
NV63-SV	63A	17	37	13	45	47
NV63-HV	63A	17	35	13	43	43
NV125-CV	125A	13	30	13	47	43
NV125-SV	125A	14	30	15	45	43
NV125-HV	125A	14	32	14	42	43
NV250-CV	250A	21	37	14	43	44
NV250-SV	250A	21	39	18	47	43
NV250-HV	250A	23	38	17	48	43

Model	Conducting current	Measurement point				
		Cover surface (A)	Base side (B)	Handle (C)	Line terminal (D)	Load terminal (E)
NV400-CW	400A	22	32	11	46	41
NV400-SW	400A	23	32	12	47	42
NV400-SEW	400A	16	23	10	36	34
NV400-HEW	400A	15	22	11	35	35
NV630-CW	630A	24	34	17	54	52
NV630-SW	630A	23	33	16	53	53
NV630-SEW	630A	23	34	17	54	53
NV630-HEW	630A	22	33	17	54	52
NV800-SEW	800A	29	40	13	53	46

Notes \*1 The connected wire size follows JIS C 8201 Ann.2 Standards. The temperature rise value will vary according to the size of the connected wire.  
 \*2 This table shows the temperature-rise values. The ambient temperature must be added for the actual measurement value.  
 \*3 These are examples of the measurement values, and are not guaranteed values. Use these as reference data.

# 8. Ordering Information

## ● Molded Case Circuit Breakers

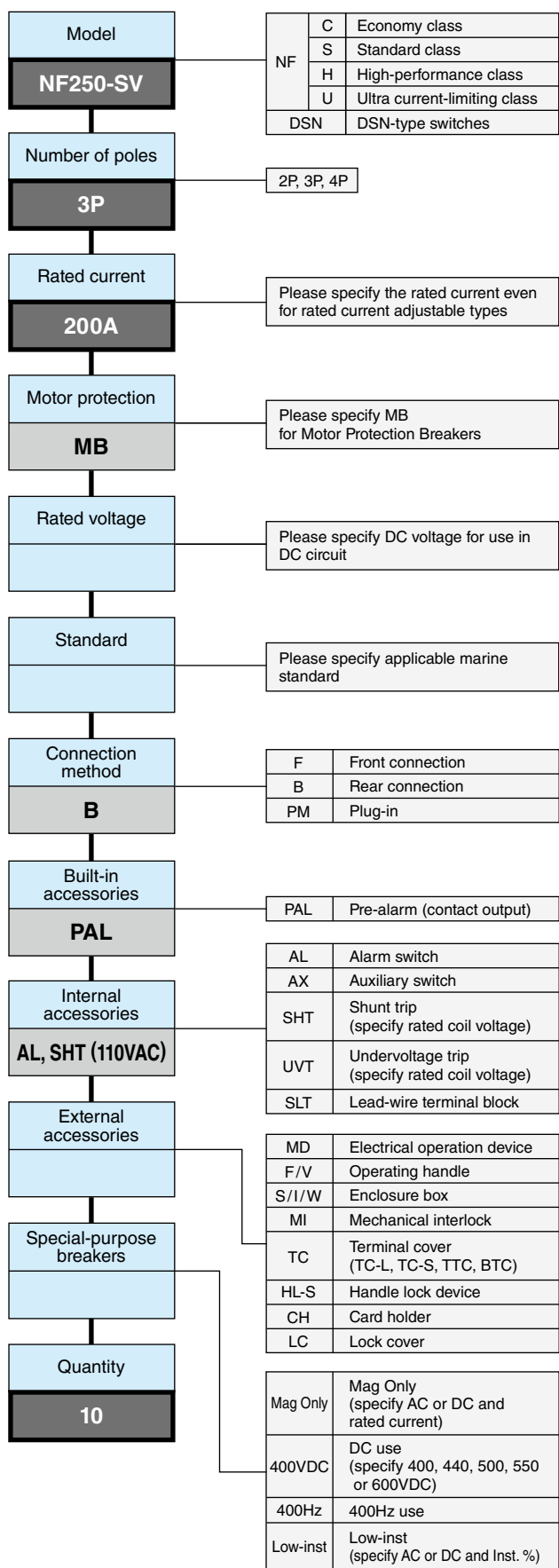

## ● Earth Leakage Circuit Breakers

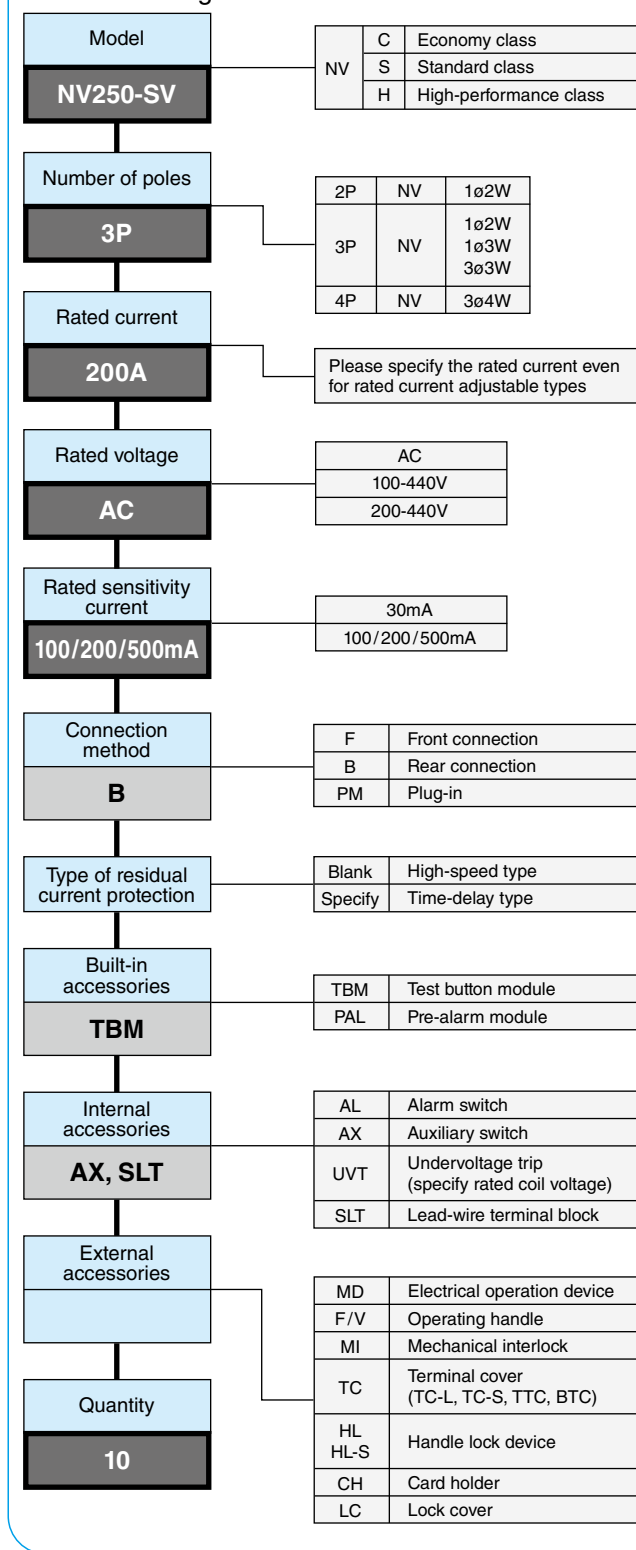

**□** Mandatory items are indicated with a bold box. Always specify these items.

Unless specified, all other items will be manufactured with standard Mitsubishi specifications.

## ● Circuit Protector (CP30-BA)

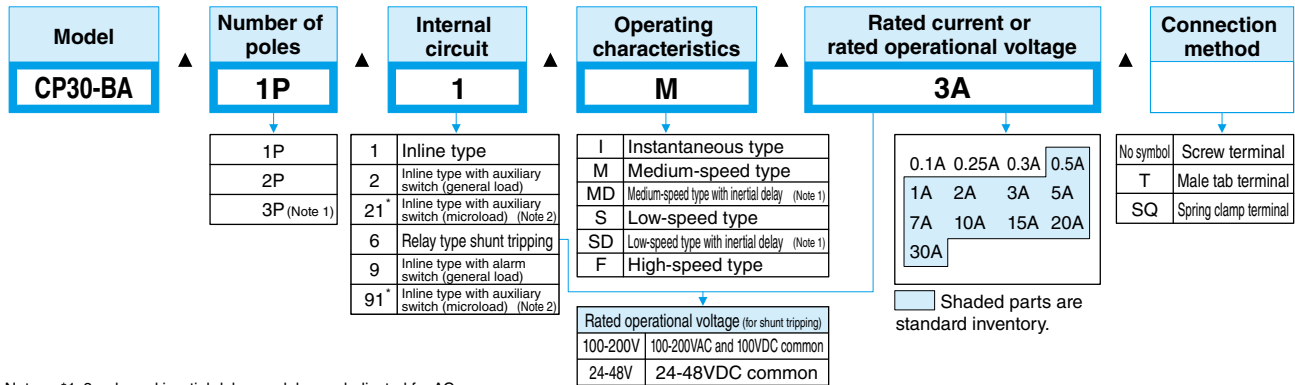

Notes \*1 3-pole and inertial delay models are dedicated for AC.

\*2 If an auxiliary switch (AX) or alarm switch (AL) used for a 125VAC 0.5A or less circuit is required, select the microload type indicated with an asterisk\*.

\*3 The relay type shunt trip is subject to CCC. This is a UL (cURus) CE and UKCA Marking compliant product.

Example 1. CP30-BA 1P 1-M 3A (example of inline type, medium-speed, 1-pole part, 3A, screw terminal specifications)

**As a standard, this product is a UL (cURus), CE, UKCA Marking, CCC compliant product.**

## ● Circuit Protector (CP30-HU)

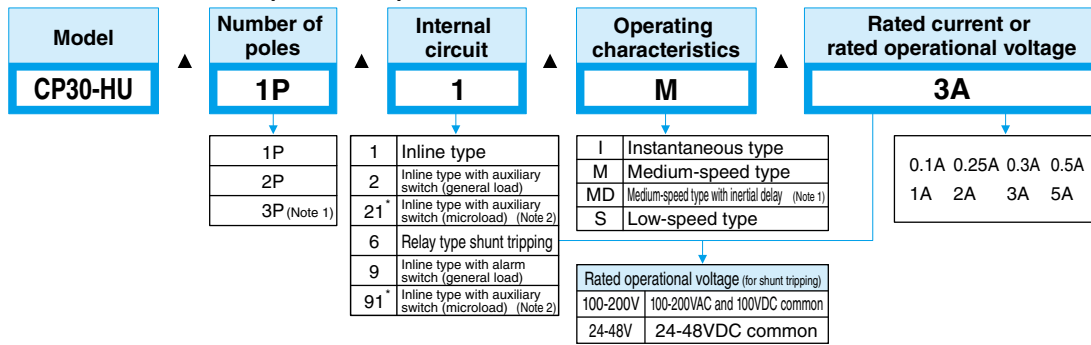

Notes \*1 3-pole and inertial delay models are dedicated for AC.

\*2 If an auxiliary switch (AX) or alarm switch (AL) used for a 125VAC 0.5A or less circuit is required, select the microload type indicated with an asterisk\*.

Example 1. CP30-HU 1P 1-M 3A (example of inline type, medium-speed, 1-pole part, 3A, screw terminal specifications)

**As a standard, this product is a UL (cURus), CE, UKCA Marking, compliant product.**

## ■ Internal accessories

### ● Specified method and list of available configurations (Screw terminal, Tab terminal)

	1P	2P	3P
No accessories	<b>□</b>	<b>□□</b>	<b>□□□</b>
Ordering patterns	1P 1- <b>□</b> <b>△</b> A	2P 1- <b>□</b> <b>△</b> A	3P 1- <b>□</b> <b>△</b> A
With AX	<b>□</b>	<b>□□</b>	<b>□□□</b>
Ordering patterns	1P 2(21)- <b>□</b> <b>△</b> A	2P 2(21)- <b>□</b> <b>△</b> A	3P 2(21)- <b>□</b> <b>△</b> A
With Multiple AX	-	<b>□□</b>	<b>□□□</b>
Ordering patterns		2P 2(21)- <b>□</b> <b>△</b> A 2) 2(21)- <b>□</b> <b>△</b> A	3P 1- <b>□</b> <b>△</b> A 2) 2(21)- <b>□</b> <b>△</b> A 2) 2(21)- <b>□</b> <b>△</b> A 3) 2(21)- <b>□</b> <b>△</b> A 3) 2(21)- <b>□</b> <b>△</b> A
With AL	<b>●</b>	<b>□●</b>	<b>□□●</b>
Ordering patterns	1P 9(91)- <b>□</b> <b>△</b> A	2P 9(91)- <b>□</b> <b>△</b> A	3P 9(91)- <b>□</b> <b>△</b> A
With AL + AX	-	<b>□●</b>	<b>□□●</b>
Ordering patterns		2P 2(21)- <b>□</b> <b>△</b> A 2) 9(91)- <b>□</b> <b>△</b> A	3P 1- <b>□</b> <b>△</b> A 2) 2(21)- <b>□</b> <b>△</b> A 2) 2(21)- <b>□</b> <b>△</b> A 3) 9(91)- <b>□</b> <b>△</b> A 3) 9(91)- <b>□</b> <b>△</b> A

□: Operating characteristics (M, MD, I, S, SD, F)  
 △: Rated current  
 □: Operating voltage (100-200V, 24-48V)

Internal accessories  
 □: Inline type, no accessories (1)  
 ○: Inline type, With AX (2(general load) or 21(micro load))  
 ●: Inline type, With AL (9(general load) or 91(micro load))  
 ■: Relay type With SHT (6)

Notes \*1 Combinations other than those listed above cannot be manufactured.  
 \*2 Only one SHT can be installed, and it must be mounted on the leftmost pole.  
 \*3 Only one AL can be installed, and it must be mounted on the rightmost pole.  
 \*4 For multiple products, the operating characteristics (□) and rated current (△) are the same for all poles. (except the pole equipped with SHT)  
 \*5 For the ratings of the alarm switch (AL) and auxiliary switch (AX), please refer to page 54.

	1P	2P	3P
With SHT	<b>■</b>	<b>■□</b>	<b>■□□</b>
Ordering patterns	1P 6 <b>□</b> V	2P 6 <b>□</b> V 2) 1- <b>□</b> <b>△</b> A	3P 6 <b>□</b> V 2) 1- <b>□</b> <b>△</b> A 3) 1- <b>□</b> <b>△</b> A
With SHT + AX	-	<b>■□</b>	<b>■□□</b>
Ordering patterns		2P 6 <b>□</b> V 2) 2(21)- <b>□</b> <b>△</b> A	3P 6 <b>□</b> V 2) 1- <b>□</b> <b>△</b> A 3) 2(21)- <b>□</b> <b>△</b> A 3) 2(21)- <b>□</b> <b>△</b> A
With SHT + AL	-	<b>■●</b>	<b>■●□</b>
Ordering patterns		2P 6 <b>□</b> V 2) 9(91)- <b>□</b> <b>△</b> A	3P 6 <b>□</b> V 2) 1- <b>□</b> <b>△</b> A 3) 9(91)- <b>□</b> <b>△</b> A
With SHT + AL + AX	-	-	<b>■●□</b>
Ordering patterns			3P 6 <b>□</b> V 2) 2(21)- <b>□</b> <b>△</b> A 3) 9(91)- <b>□</b> <b>△</b> A

<Examples of non-manufacturable configurations>

3P 1-M 10A  
 2) 2- I 10A  
 3) 9- I 10A

This configuration cannot be manufactured because the operating characteristics of the first pole differ from those of the second and third poles.

3P 1-M 15A  
 2) 2-M 15A  
 3) 9-M 10A

This configuration cannot be manufactured because the rated current of the first and second poles differs from that of the third pole.

● UL 489 Listed Molded Case Circuit Breakers

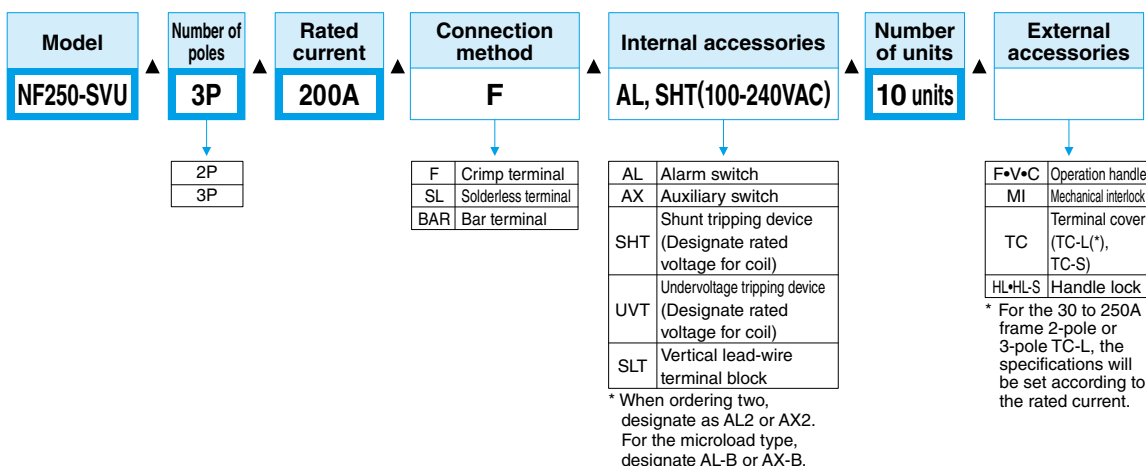

● UL 489 Listed Earth Leakage Circuit Breakers

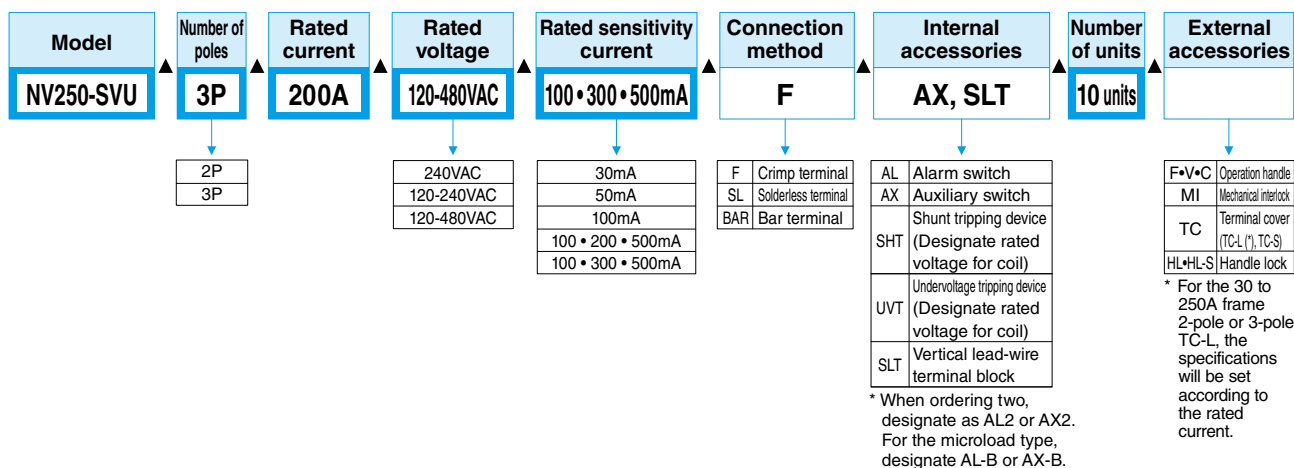

# 9. Index

	Chapter	page	Chapter	page	
A	AE	2	L	LC	6
	AL	6	M	MB	2
	AX	6		MD	6
B	B(Rear)	5		MDS	6
	BA-B	6		MDU breaker	2
	BA-F	6		MI	6
	BA-G	6	N	NFI(Dust-proof type)	6
	BA-P	6		NFS(Closed type)	6
	BAR	5		NFW(Water-proof type)	6
	BOX	6	P	P-LT	6
	B-ST	5		PAL	6
	BTC	6		PM	5
C	CE marking	4		PTC	6
	CH	6	S	S-box(Closed-type)	6
	CP	2		SHT	6
	C-type handle	6		SLT	6
D	DC MCCB	3		SQ	2
	DC DSN switch	3	T	TBM	6
	DIN rail mounting adapter	6		TC-L	6
F	F(AMP-N)	5		TC-S	6
	FAU/FHU series	2		TTC	6
	FP	5	U	UL 489 Listed	2
	F-type handle	6		UVT	6
H	HL	6	V	V-type handle	6
	HL-S	6	W	W-box(water-proof type)	6
	HT	6	Y	Y-360	9
I	I-box(Dust-proof type)	6	Z	ZCT	2
	IEC 35-mm rail mounting adapter	6		ZT	2

## 10. MELSELECT™

### Short-circuit current calculation and model selection software

MELSELECT is the software that calculates short circuit current and autoselects suitable products from Mitsubishi Electric ranges for circuit protection.

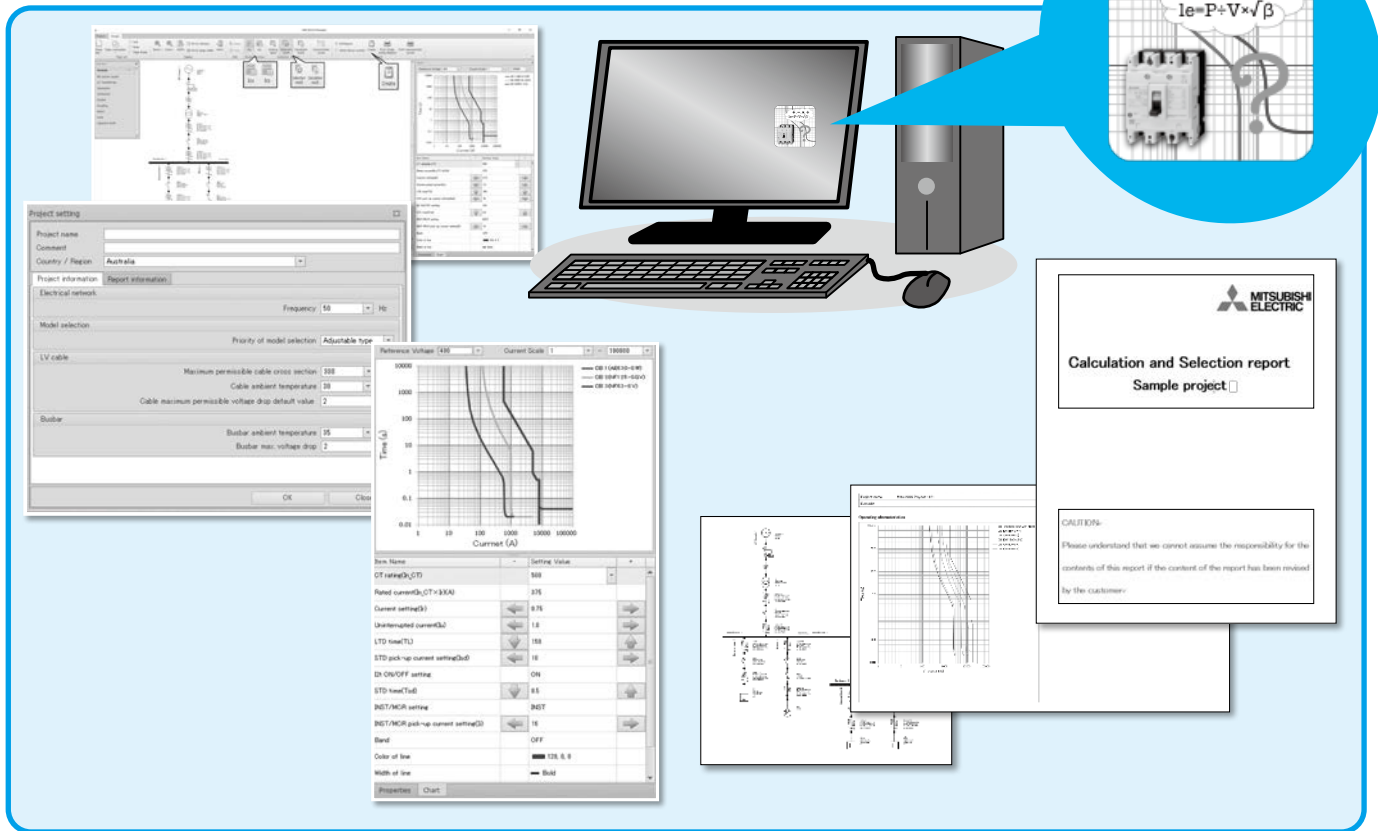

***MELSELECT simplifies the circuit design and improves the work rate!***

#### ● Registered Products

Low-voltage Power Distribution Products: ACBs, MCCBs, ELCBs, MCBs, Contactors, Thermal relays

#### ● Features

- Calculating short circuit current and auto-selecting the suitable combination of installation components from Mitsubishi Electric ranges.
- Outputting a report of calculation and selection results.
- Checking coordination by comparing the characteristics of the selected products.
- Multi-languages available. (Japanese, English, Chinese)
- Widely-used in the world. (57 countries and regions)
- Compatibility with Windows 10.
- IEC based SLD (Single Line Diagram) indication.
- Free software open to public on Mitsubishi Electric FA Global Website and off-line operating.

#### ● System Requirements

- Operating system (OS): Microsoft Windows 10 (32/64 bit) Pro.
  - Microsoft .NET Framework: Microsoft .NET Framework 4.6.
- \* Microsoft, Windows, .NET Framework and Word are registered trademarks of Microsoft Corporation in the United States and other countries.

#### ● Download Link

<http://www.mitsubishielectric.com/fa/products/lvd/lvcb/smerit/melselect/index.html>

# 11. Low Voltage Products Website



*Changes for the Better*

<https://www.mitsubishielectric.com/fa/>

— Easier to Navigate, More Information Available —

Whether you are looking for information on high-performance power distribution/protection systems and energy-saving support equipment or simply interested in one of our many low-voltage power control products, we've made things easier for you to find. The website is now organized to provide enhanced usability for customers, and the latest information on our low-voltage products and systems. Please be sure to visit, check out our new look, and bookmark the site for future reference.



## Four Key Features

### 1 Product Information

Based on past customer requests, we've increased the content to include a full product line-up, product specifications and relevant CAD data. The Products pages are divided into two categories:

#### Low-voltage Circuit Breakers

WS-V Series Next-generation MCCB and ELCB, AE-SW Series ACB, DIN Series MCB

#### Energy Measuring Devices

New SS series Multi-measuring instruments, EcoMoniorPlus Energy Measuring Unit

### 2 Downloads

The latest catalogs, information on certifications acquired, handling and maintenance information, and technical notes can all be downloaded free of charge. We've organized the information for maximum customer convenience, and will be updating the contents periodically.

### 3 News

Check here for the latest, up-to-date news on Mitsubishi Electric products such as new product releases and changes in specifications.

### 4 Support

Our interest is to serve you! Please contact us whenever you have a question or are in need of support. We'll reply at the earliest possible time. Committed to supporting our customers' businesses, we also provide information through Mitsubishi Electric's global network.

Empowering  
Industries

## 12. Service Network

Country/Region	Corporation Name	Address	Telephone
Australia	Mitsubishi Electric Australia Pty. Ltd.	348 Victoria Road, Rydalmere, N.S.W. 2116, Australia	+61-2-9684-7777
Algeria	Mec Casa	Rue i N 125 Hay-Es-Salem, 02000, W-Chef, Algeria	+213-27798069
Bangladesh	PROGRESSIVE TRADING CORPORATION ELECTRO MECH AUTOMATION & ENGINEERING LTD.	HAQUE TOWER, 2ND FLOOR, 610/11, JUBILEE ROAD, CHITTAGONG, BANGLADESH SHATABDI CENTER, 12TH FLOOR, SUITES: 12-B, 292, INNER CIRCULAR ROAD, FAKIRA POOL, MOTIJHEEL, DHAKA-1000, BANGLADESH	+880-31-624307 +88-02-7192826
Belarus	Technikon	Oktyabrskaya 19, Off. 705, BY-220030 Minsk, Belarus	+375 (0)17 / 210 46 26
Belgium	Mitsubishi Electric Europe B.V. Benelux Branch	Nijverheidsweg 23A, 3641 RP Mijdrecht	+31 (0)297 250 350
Brazil	Mitsubishi Electric do Brasil Comércio e Serviços Ltda.	Avenida Adelino Cardana, 293 – 21º Andar, Bethaville, Barueri, SP, Brasil, CEP 06401-147	+55-11-4689-3000
Cambodia	DHINIMEX CO.,LTD Pump Electric Solution CO.,LTD.	#245, St. Tep Phan, Phnom Penh, Cambodia C19 Street R8, Phnom Penh 120210, Cambodia	+855-23-997-725 +855-12-318-190
Central America	Automation International LLC	7050 W. Palmetto Park Road Suite #15 PMB #555, Boca Raton, FL 33433	+1-561-237-5228
Chile	Rhona S.A. (Main office)	Vte. Agua Santa 4211 Casilla 30-D (P.O. Box) Vina del Mar, Chile	+56-32-2-320-600
China	Mitsubishi Electric Automation (China) Ltd.	Mitsubishi Electric Automation Building, No.1386 Hongqiao Road, Shanghai, China 200336	+86-21-2322-3030
	Mitsubishi Electric Automation (China) Ltd. BeiJing	5/F, ONE INDIGO, 20 Juxianqiao Road Chaoyang District, Beijing, China 100016	+86-10-6518-8830
	Mitsubishi Electric Automation (China) Ltd. ShenZhen	Level 8, Galaxy World Tower B, 1 Yabao Road, Longgang District, Shenzhen, China 518129	+86-755-2399-8272
	Mitsubishi Electric Automation (China) Ltd. GuangZhou	Rm.1006, A1 Times E-Park, No.276-282, Hanxi Road East, Zhongcun Street, Panyu Distric, Guangzhou, China 510030	+86-20-8923-6730
	Mitsubishi Electric Automation (China) Ltd. ChengDu	1501-1503, 15F, Guang-hua Centre Building-C, No.98 North Guang Hua 3th Rd Chengdu, China 610000	+86-28-8446-8030
Mitsubishi Electric Automation (Hong Kong) Ltd.	20/F, 1111 King's Road, Taikoo Shing, Hong Kong	+852-2510-0555	
Colombia	Proelectrico Representaciones S.A.	Carrera 42 N° 75 – 367 Bodega 109, Itagüí, Medellín, Antioquia, Colombia	+57-4-4441284
Czech Republic	AUTOCONT CONTROL SYSTEMS S.R.O	Technologická 374/6, CZ-708 00 Ostrava - Pustkovec	+420 595 691 150
Denmark	BEIJER ELECTRONICS A/S	LYKKEGARDSVEJ 17, DK-4000 ROSKILDE, Denmark	+45 (0)46 75 76 66
Egypt	Cairo Electrical Group	9, Rostoum St. Garden City P.O. Box 165-11516 Maglis El-Shaab, Cairo - Egypt	+20-2-27961337
France	Mitsubishi Electric Europe B.V. French Branch	FR-92741 Nanterre Cedex	+33 (0)1 55 68 57 01
Germany	Mitsubishi Electric Europe B.V.	Mitsubishi-Electric-Platz 1, 40882 Ratingen, Germany	+49 (0) 2102 4860
Greece	KALAMARAKIS - SAPOUNAS S.A.	IONIAS & NEROMILOU STR., CHAMOMILOUS ACHARNES, ATHENS, 13678 Greece	+30-2102 406000
Hungary	Meltrade Ltd.	Fertő utca 14. HU-1107 Budapest, Hungary	+36 (0)1-431-9726
India	Mitsubishi Electric India Private Limited	3rd Floor, Tower A, Global Gateway, MG Road, Gurugram - 122002, Haryana, India	+91(124)673 9300
	Mitsubishi Electric India Private Limited Pune Sales Office	ICC-Devi Gaurav Technology Park, Unit no. 402, Fourth Floor, Survey no. 191-192 (P), Opp. Vallabh Nagar Bus Depot, Pune – 411018, Maharashtra, India	+91-20-68192100
	Mitsubishi Electric India Private Limited FA Center	204-209, 2nd Floor, 31FIVE, Corporate Road, Prahladnagar, Ahmedabad 380015, Gujarat, India	+91-79677-77888
Indonesia	PT. Sahabat Indonesia	P.O.Box 5045 Kawasan Industri Pergudangan, Jakarta, Indonesia	+62-(0)21-6610651-9
Ireland	Mitsubishi Electric Europe B.V.	Westgate Business Park, Ballymount, IRL-Dublin 24, Ireland	+353 (0)1-4198800
Israel	Gino Industries Ltd.	26, Ophir Street IL-32235 Haifa, Israel	+972 (0)4-867-0656
Italy	Mitsubishi Electric Europe B.V.	Viale Colleoni 7, I-20041 Agrate Brianza (MI), Italy	+39 039-60531
Kazakhstan	Kazpromavtomatika	Ul. Zhambyla 28, KAZ - 100017 Karaganda	+7-7212-501000
Korea	Mitsubishi Electric Automation Korea Co., Ltd	9F Gangseo Hangang xi-tower A, 401 Yangcheon-ro, Gangseo-gu, Seoul 07528 Korea	+82-2-3660-9573
Laos	AROUNKIT CORPORATION IMPORT- EXPORT SOLE CO.,LTD	SAPHANMO VILLAGE. SAYSETHA DISTRICT, VIENTIANE CAPITAL, LAOS	+856-20-415899
Lebanon	Comptoir d'Electricite Generale-Liban	Cebaco Center - Block A Autostrade Dora, P.O. Box 11-2597 Beirut - Lebanon	+961-1-240445
Lithuania	Rifas UAB	Tinklu 29A, LT-5300 Panevezys, Lithuania	+370 (0)45-582-728
Malaysia	Mitric Sdn Bhd	No. 5 Jalan Pemberita U1/49, Temasya Industrial Park, Glenmarie 40150 Shah Alam, Selangor, Malaysia	+603-5569-3748
Malta	ALFATRADE LTD	99 PAOLA HILL, PAOLA PLA 1702, Malta	+356 (0)21-697-816
Marocco	SCHIELE MAROC	KM 7,2 NOUVELLE ROUTE DE RABAT AIN SEBAA, 20600 Casablanca, Marocco	+212 661 45 15 96
Myanmar	Peace Myanmar Electric Co.,Ltd.	NO137/139 Botahtaung Pagoda Road, Botahtaung Town Ship 11161, Yangon, Myanmar	+95-(0)1-202589
Nepal	Watt&Volt House	KHA 2-65, Volt House Dillibazar Post Box:2108, Kathmandu, Nepal	+977-1-4411330
Netherlands	Mitsubishi Electric Europe B.V. Benelux Branch	Nijverheidsweg 23A, 3641 RP Mijdrecht	+31 (0)297 250 350
North America	Mitsubishi Electric Automation, Inc.	500 Corporate Woods Parkway, Vernon Hills, IL 60061 USA	+847-478-2100
Norway	Scanelec AS	Leivikasen 43B, NO-5179 Godvik, Norway	+47 (0)55-506000
Mexico	Mitsubishi Electric Automation, Inc. Mexico Branch	Blvd. Miguel de Cervantes Saavedra 301, Torre Norte Piso 5, Col. Ampliación Granada, Miguel Hidalgo, Ciudad de México, CP 11520, México	+52-55-3067-7511
Middle East Arab Countries & Cyprus	Comptoir d'Electricite Generale-International-S.A.L.	Cebaco Center - Block A Autostrade Dora P.O. Box 11-1314 Beirut - Lebanon	+961-1-240430
Pakistan	Prince Electric Co. STRA AUTOMATION	2-P GULBERG II, LAHORE, 54600, PAKISTAN 157-F, Block F Phase 1 Johar Town, Lahore, 54782, Pakistan	+92-42-575232, 5753373 +92-42-35175265/66
Peru	Rhona S.A. (Branch office)	Avenida Argentina 2201, Cercado de Lima	+51-1-464-4459
Philippines	MELCO Factory Automation Philippines Inc. Edison Electric Integrated, Inc.	128, Lopez Rizal St., Brgy. Highway Hills, Mandaluyong City, Metro Manila, Philippines 24th Fl. Galleria Corporate Center, Edsa Cr. Ortigas Ave., Quezon City Metro Manila, Philippines	+63-(0)2-256-8042 +63-(0)2-634-8691
Poland	Mitsubishi Electric Europe B.V. Polish Branch	Krakowska 48, 32-083 Balice, Poland	+48 12 347 65 00
Republic of Moldova	Intehsis SRL	bld. Traian 23/1, MD-2060 Kishinev, Moldova	+373 (0)22-66-4242
Romania	Sirius Trading & Services SRL	RO-060841 Bucuresti, Sector 6 Aleea Lacul Morii Nr. 3	+40-(0)21-430-40-06
Russia	Mitsubishi Electric (Russia) LLC	2 bld.1, Letnikovskaya street, Moscow, 115114, Russia	+7 495 721-2070
Saudi Arabia	Center of Electrical Goods	Al-Shuwayer St. Side way of Salahuddin Al-Ayoubi St. P.O. Box 15955 Riyadh 11454 - Saudi Arabia	+966-1-4770149
Singapore	Mitsubishi Electric Asia Pte. Ltd. PROCONT, Presov	307 Alexandra Road, Mitsubishi Electric Building, Singapore 159943 Kupelna 1/, SK - 08001 Presov, Slovakia	+65-6473-2308 +421 (0)51 - 7580 611
Slovakia	SIMAP	Jana Derku 1671, SK - 91101 Trenčin, Slovakia	+421 (0)32 743 04 72
Slovenia	Inea RBT d.o.o.	Stegne 11, SI-1000 Ljubljana, Slovenia	+386 (0)1-513-8116
South Africa	CBI-electric: low voltage	Private Bag 2016, ZA-1600 Isando Gauteng, South Africa	+27-(0)11-9282000
Spain	Mitsubishi Electric Europe B.V. Spanish Branch	Carretera de Rubí 76-80, E-08190 Sant Cugat del Vallés (Barcelona), Spain	+34 (0)93-565-3131
Sweden	Mitsubishi Electric Europe B.V. (Scandinavia) Euro Energy Components AB	Hedvig Möllers gata 6, 223 55 Lund, Sweden Järnvägsgatan 36, S-434 24 Kungsbacka, Sweden	+46 (0)8-625-10-00 +46 (0)300-690040
Switzerland	TriElec AG	Muehlentalstrasse 136, CH-8201 Schaffhausen, Switzerland	+41-(0)52-6258425
Taiwan	Mitsubishi Electric Automation (Taiwan) Co.,Ltd	3F., No.105, Wugong 3rd Rd, Wugu Dist., New Taipei, 248019, Taiwan, R.O.C.	+886-(0)2-2298-8889
Thailand	United Trading & Import Co., Ltd.	77/12 Bamrungmuang Road, Klong Mahanak Pomrab Bangkok Thailand	+66-223-4220-3
Tunisia	MOTRA Electric	3, Résidence Imen, Avenue des Martyrs Mourouj III, 2074 - El Mourouj III Ben Arous, Tunisia	+216-71 474 599
Turkey	Mitsubishi Electric Turkey A.Ş.	Şerifali Mahallesi Kale Sokak No: 41, 34775 Ümraniye, İstanbul, Turkey	+90-216-969-2666
United Kingdom	Mitsubishi Electric Europe B.V.	Travellers Lane, UK-Hatfield, Herts. AL10 8XB, United Kingdom	+44 (0)1707-276100
Uruguay	Fierro Vignoli S.A.	Avda. Uruguay 1274 Montevideo Uruguay	+598-2-902-0808
Vietnam	Mitsubishi Electric Vietnam Co.,Ltd. Head Office	11th & 12th Floor, Viettel Building, 285 Cach Mang Thang 8 Street, Hoa Hung Ward, Ho Chi Minh City, Vietnam	(+84) 28 3910 5945
	Mitsubishi Electric Vietnam Co.,Ltd. Hanoi Branch	14th Floor, Capital Tower, 109 Tran Hung Dao Street, Cua Nam Ward, Ha Noi, Viet Nam	(+84) 24 3937 8075

## Creating Solutions Together.



Industrial Computer



Controllers



Computerized Numerical Controllers



Drive Products



Human Machine Interfaces



Robots



Low-voltage Power Distribution Products



Medium-voltage Power Distribution Products



Energy Saving Supporting Devices



Processing Machines: EDM, Lasers



Engineering and Solution Software

Mitsubishi Electric's FA division provides robust support for our customers' manufacturing needs. We offer a vast array of FA products, including industry-leading PLCs, control devices, drive devices, energy efficiency support equipment, power distribution control equipment, and industrial mechatronics. Our presence on every type of production floor enables us to assist in labor-saving initiatives and quality improvements, helping customers achieve sustainable manufacturing. We also address challenges such as decarbonization and labor shortages through the utilization of automation technology.

Additionally, by leveraging synergies among FA technologies, manufacturing expertise, and digital innovations, we aim to streamline the construction of systems for data collection, accumulation, and analysis. This contributes to reducing manufacturing and quality losses.

We enable flexible manufacturing processes that respect legacy systems while embracing innovations to drive optimization. As your solution partner, Mitsubishi Electric FA delivers high-performance, high-quality products that enhance your competitiveness.

Let's automate the world together!

# Low Voltage Circuit Breakers

**For Safety** : Please read the instruction manual carefully before using the products in this catalog.  
Wiring and connection must be done by the person have a specialized knowledge of electric construction and wiring.



Mitsubishi Electric's e-F@ctory concept utilizes both FA and IT technologies, to reduce the total cost of development, production and maintenance, with the aim of achieving manufacturing that is a "step ahead of the times". It is supported by the e-F@ctory Alliance Partners covering software, devices, and system integration, creating the optimal e-F@ctory architecture to meet the end users needs and investment plans.



**MITSUBISHI ELECTRIC CORPORATION**

HEAD OFFICE: TOKYO BUILDING, 2-7-3, MARUNOUCHI, CHIYODA-KU, TOKYO 100-8310, JAPAN